



OPERATOR'S MANUAL

10 *SERIES*
AIR CART

North America
N72800-02

Table of Contents

Section 1:	
Safety	1-1
Signal Words	1-2
General Operation	1-3
Tractor Operation	1-3
Chemicals.....	1-4
Transporting.....	1-5
Hydraulics.....	1-5
Maintenance.....	1-6
Storage.....	1-6
Conveyor Safety	1-7
General	1-7
Safety Signs	1-8
Decals	1-13
Front.....	1-15
Rear	1-16
Left Side - Tow Between.....	1-17
Right Side - Tow Between	1-18
Left Side - Tow Behind.....	1-19
Right Side - Tow Behind	1-20
Top.....	1-21
ICT Meter Body.....	1-22
Conveyor	1-23
Lighting and Marking.....	1-24
Section 2:	
Specifications	2-1
Dimensions.....	2-2
660, 820 and 1050 - Tow Between	2-4
660 and 820 - Tow Behind.....	2-5
1050 Cart - Tow Behind	2-6
1440 - Tow Behind	2-7
Section 3:	
Checklist	3-1
Manuals.....	3-2
Parts Manual	3-2
Assembly Manual.....	3-2
Checklist.....	3-3
Section 4:	
Introduction	4-1
Introduction.....	4-2
Features	4-3
Topcon XD+ 12.1 Console.....	4-3
Morris Electric Drive System	4-4
Metering System	4-5
Convenient Adjustments.....	4-6
Hydraulic Conveyor	4-6
High Capacity Fans	4-7
Weigh Scale	4-7
Section 5:	
Operation	5-1
Application.....	5-3
Tractor.....	5-3
Tractor Drawbar Requirements.....	5-4

Table of Contents

Tractor Hydraulic Connections	5-4
Monitor Installation	5-5
Hitching to Tractor (Seeding Tool or Tow Between Cart)	5-7
Hitching to Seeding Tool (Tow Between Cart)	5-9
Hitching to Seeding Tool (Tow Behind Cart)	5-10
Unhitching from Seeding Tool (Tow Between Cart)	5-11
Unhitching from Tractor (Seeding Tool or Tow Between Cart)	5-12
Unhitching from Seeding Tool (Tow Behind Cart)	5-13
Quad Steer Operation	5-14
Transport	5-15
Speed	5-15
Lights	5-15
Brakes	5-16
In-Cab Brake Controller	5-16
Operation	5-17
Installation	5-18
Metering System	5-20
Secondary Hose Installation	5-21
Seed Plate Setting	5-23
Seed Plate Adjustment	5-24
Weigh Scale	5-25
Auxiliary Power Unit (APU)	5-26
Switch Box	5-27
Conveyor	5-27
Transmitter Functions	5-27
To Register Transmitter to the Reciever	5-28
Transport to Tank Fill / Dump Position	5-29
Transport Position	5-31
Conveyor Break-In	5-33
Befor Starting Work	5-33
Operating for first 1/2 hour	5-33
After Operating for 5 hours and 10 hours	5-33
Pre-Operation Checklist	5-34
Operation Procedure	5-34
Operation Procedure	5-35
Stopping Conveyor	5-35
Emergency Stopping	5-35
Operating Hints	5-36
Optimizer Tank Filling	5-37
Filling Tank	5-41
Unloading Tanks	5-43
Rate Calibration	5-45
Metering Rate Adjustment	5-47
Applying Inoculant	5-47
Airguard Blockage Prevention System	5-48
Start Up Procedure	5-48
Preventative Maintenance	5-48
Hydraulic Fan Drive	5-50
Fan Speed Recommendations	5-51
Double Shoot Settings	5-54
Collector Valve Settings	5-54
Flapper Valve Run Test	5-54
Operating Guidelines	5-55
Seed Rate Settings	5-55
Fertilizer Application	5-55
Fan Setting	5-55

Table of Contents

Product Application.....	5-55
Checking Seed Flow	5-56
Moisture Alert	5-56
Air Leaks	5-56
Tank Low in Product	5-56
Monitor	5-57
General Field Operation	5-57
Section 6:	
Maintenance.....	6-1
General.....	6-2
Safety	6-2
Tighten Bolts	6-3
Tires	6-4
Daily Maintenance	6-5
Lubrication.....	6-6
Air Delivery System	6-7
General	6-7
Tank Lid Adjustment	6-8
Inspection Door Adjustment	6-9
Clean Out Door Adjustment	6-10
Air Leak Check.....	6-11
Fan	6-12
Rotor Clearance	6-13
Hoses.....	6-13
Equalizers	6-14
Fan Motor	6-15
Hydraulics.....	6-16
Wheel Bearings.....	6-17
Quad Steer	6-18
Dual Wheels	6-19
660 Cart - Rear Duals	6-19
1440 Cart - Front Duals	6-19
820, 1050 and 1440 Cart - Rear Duals.....	6-23
Rear Axle Extentions	6-26
Torque Rear Axle Hardware	6-26
Seed Plate Adjustment.....	6-27
Gearbox Removal / Installation.....	6-28
Auxiliary Power Unit (APU).....	6-30
Brakes	6-32
Fill Reservoir	6-32
Bleeding Brakes	6-32
Single Caliper Brake Bleeding	6-32
Dual Caliper Brake Bleeding.....	6-33
Brake Pads	6-34
Caliper Pistons and Seal Replacement.....	6-34
Conveyor	6-35
4.1 Fluids and Lubricants	6-35
4.2 Servicing Intervals.....	6-36
4.3 Maintenance Procedures	6-37
Section 7:	
Storage	7-1
Preparing for Storage	7-2
General	7-2
Tank Clean Out For Storage.....	7-3

Table of Contents

Removing From Storage.....	7-4
General	7-4
Monitor	7-4
Auger	7-4
Conveyor.....	7-4
Brakes.....	7-4
Section 8:	
Troubleshooting.....	8-1
General	8-2
Delivery hoses plugged.....	8-2
Hydraulic fan will not turn.....	8-2
Fan turning too slow.....	8-2
Material flowing thru system when unit is stationary and the fan running.....	8-2
Material not being metered out	8-3
Material not being accurately metered out of the metering body	8-4
Plugged seed boots	8-4
APU.....	8-5
Batteries not charging	8-5
Metering System	8-5
Motor Torque High.....	8-5
Monitor	8-6
Monitor lights up but does not seem to work	8-6
No fan display	8-6
No display, no back light	8-6
Brakes	8-7
Fan	8-8
Air Guard System.....	8-9
Conveyor.....	8-10

Section 1: Safety

Section Contents

Signal Words	1-2
General Operation	1-3
Tractor Operation	1-3
Chemicals	1-4
Transporting	1-5
Hydraulics	1-5
Maintenance	1-6
Storage	1-6
Conveyor Safety	1-7
General	1-7
Safety Signs	1-8
Decals	1-13
Front	1-15
Rear	1-16
Left Side - Tow Between	1-17
Right Side - Tow Between	1-18
Left Side - Tow Behind	1-19
Right Side - Tow Behind	1-20
Top	1-21
ICT Meter Body	1-22
Conveyor	1-23
Lighting and Marking	1-24

Safety

SAFETY-ALERT SYMBOL



Watch for this symbol. It identifies potential hazards to health or personal safety. It means:

ATTENTION - BE ALERT.
Your Safety is involved.

Familiarize yourself with the location of all decals. Read them carefully to understand the safe operation of your machine.

Signal Words

The words **DANGER**, **WARNING** or **CAUTION** are used with the safety alert symbol. Learn to recognize the safety alerts, and follow the recommended precautions and safe practices.

Three words are used in conjunction with the safety-alert symbol:



DANGER

Indicates an imminently hazardous situation that, if not avoided, will result in **DEATH OR SERIOUS INJURY**.



WARNING

Indicates a potentially hazardous situation that, if not avoided, could result in **DEATH OR SERIOUS INJURY**.



CAUTION

Indicates a potentially hazardous situation that, if not avoided, may result in **MINOR OR MODERATE INJURY**.

Replace any **DANGER**, **WARNING**, **CAUTION** or instructional decal that is not readable or is missing. The location and part number of these decals is identified later in this section of the manual.

The words **Important** and **Note** are not related to personal safety but are used to give additional information and tips for operating or servicing this equipment.

IMPORTANT: Identifies special instructions or procedures which, if not strictly observed could result in damage to, or destruction of the machine, process or its surroundings.

NOTE: Indicates points of particular interest for more efficient and convenient repair or operation.

General Operation

- **DO NOT RIDE!!** Do not allow riders on the implement when in motion.
- Do not allow extra riders in the tractor unless an instructor seat and seat belt are available.
- **Check behind** when backing up.
- **Reduce speed** when working in hilly terrain.
- Never allow anyone within the immediate area when operating machinery.
- **Keep all shields in place**, replace them if removed for service work.
- Always lock auger attachment in raised position.
- Keep hands clear of tank opening when closing lid. Keep lid seal clean to ensure proper sealing.
- **Do Not enter tank unless another person is present and the tractor engine has been shut off.**

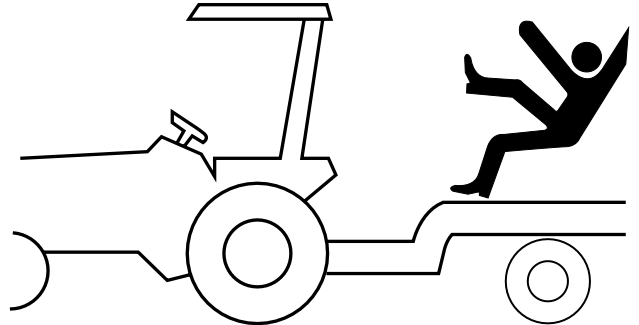

Tractor Operation

- Be aware of the correct tractor operating procedures, when working with implements.
- Review tractor operator's manual.
- Secure hitch pin with a retainer and lock drawbar in centre position.

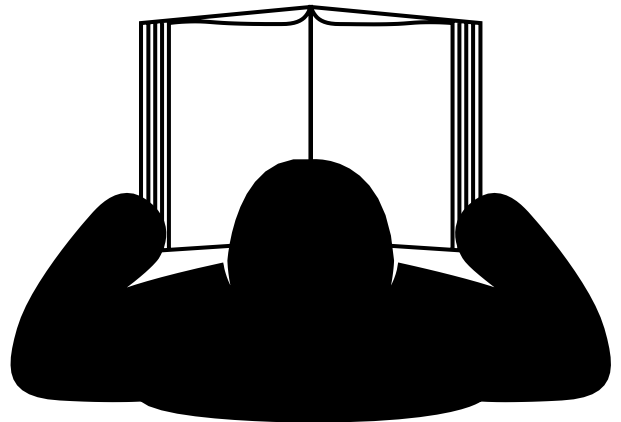

Safety

Chemicals

- **Use extreme care** when cleaning, filling or making adjustments.
- **Always read** granular chemical or treated seed manufacturer's warning labels carefully and follow them.
- Wear close fitting clothing and appropriate personal protective equipment for the job as specified by the chemical and/or seed manufacturer.
- **Always wear** safety goggles, breathing apparatus and gloves when handling granular chemical or treated seed.
- **Do not feed** any treated seed to livestock. Treated seed is poisonous and may cause harm to persons or livestock.
- **Wash exposed skin immediately** - do not leave chemicals on your skin.
- **Properly store** chemicals in original containers with labels intact per the manufacturer's instructions.
- Always follow the manufacturer's operating instructions and warning labels when operating an ammonia tank with the equipment.
- **Do Not enter tank unless another person is present and the tractor engine has been shut off.**



Danger

Failure to comply may result in serious injury or death.

Read Operator's Manual and decals on **Ammonia** tank before operating air cart. Become familiar with all warnings, instructions, and controls.

Always wear gloves and goggles when transferring or handling ammonia.

Always stay clear of hose and valve openings.

Always be sure pressure is relieved before disconnecting hoses or parts.

Always secure connecting parts and safety chains before towing ammonia trailer.

Always have ample water available in case of exposure to ammonia liquid or gases.

Transporting

- **Be aware** of the height, length and width of implement. Make turns carefully and be aware of obstacles and overhead electrical lines.
- Empty tanks before transporting. Do Not Exceed 20 mph (30 km/h) with an empty air cart.
- Use an agricultural tractor that is large enough with sufficient braking capacity so that the weight of the loaded equipment towed does not exceed 1.5 times the weight of the tractor.
- Be familiar with, and adhere to, local laws. Use flashing amber warning lights, turn signals and SMV emblems when on public roads.
- Do not transport in poor visibility.
- The slow moving vehicle (SMV) emblem, speed identification symbol (SIS) and reflectors must be secured and be visible on the machine for transport.
- When towing equipment combinations, the maximum equipment combination ground speed shall be limited to the lowest specified ground speed of any of the towed machines.
- Avoid soft surfaces, the additional wing weight on the centre wheels could cause the machine to sink.
- Ensure safety chain(s) is attached correctly to the towing vehicle and the hitch of the air cart.
- Check that wings are firmly seated in transport wing stops, and lock pins installed.
- Secure transport locks on depth control cylinders.

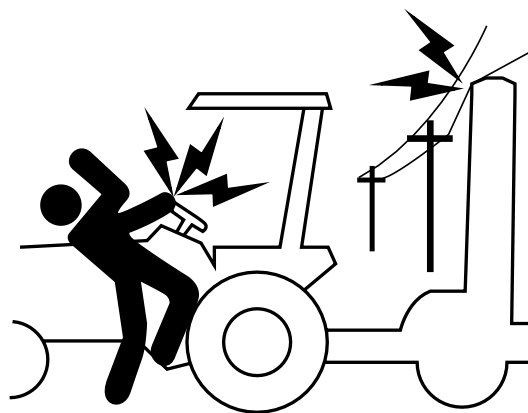

Hydraulics

- **Do not** search for high pressure hydraulic leaks without hand and face protection. A tiny, almost invisible leak can penetrate skin, thereby requiring immediate medical attention.
- Use cardboard or wood to detect hydraulic leaks - never your hands.
- Double check that all is clear before operating hydraulics.
- **Never** remove hydraulic hoses or ends with machine elevated. Relieve hydraulic pressure before disconnecting hydraulic hoses or ends.
- Maintain proper hydraulic fluid levels.
- Keep all connectors clean for positive connections.
- Ensure all fittings and hoses are in good condition.
- Do not stand under wings.

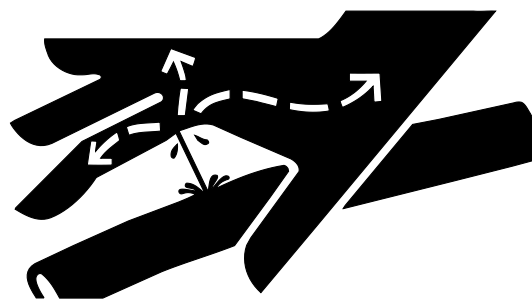

Safety

Maintenance

- **Shut tractor engine off** before making any adjustments or lubricating the machine.
- **Block** machine securely to prevent any movement during servicing.
- Wear close fitting clothing and appropriate personal protective equipment for the job.
- **Always wear** safety goggles, breathing apparatus and gloves when working on seeder filled with granular chemical or treated seed per the manufacture's instructions.
- Do not modify the machine.

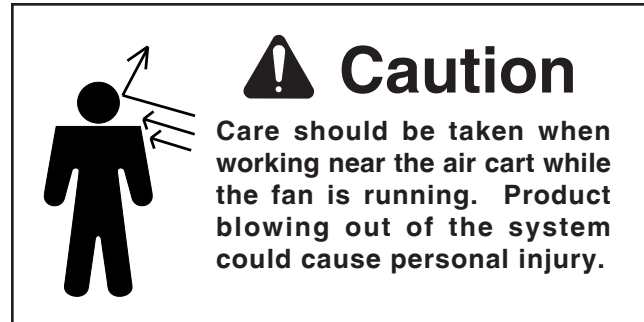

Storage

- Store implement away from areas of main activity.
- Level implement and block up securely to relieve pressure on jack.
- Do not allow children to play on or around stored implement.
- Refer to Storage Section for more details.

Conveyor Safety

General

- As the owner and/or operator it is your responsibility to know what requirements, hazards and precautions exist, and to inform all personnel associated with the equipment or are in the area.
- Avoid any alteration to the equipment. Such alterations may produce a very dangerous situation, where serious injury or death may occur.
- Untrained operators subject themselves and other to serious injury or death. **NEVER ALLOW** untrained personnel to operate this equipment.
- Keep children and other unqualified personnel out of the working area at all times.
- **NEVER** start equipment until **ALL** persons are clear of the work area.
- Be sure **ALL** operators are adequately rested and prepared to perform all functions of operating this equipment.
- Keep hair, loose clothing, and shoestrings away from rotating and moving parts. Never wear loose fitting clothing when working around conveyors.
- **NEVER** allow anyone inside a bin, truck, or wagon which is being unloaded by a conveyor. Flowing grain can trap and suffocate in seconds.
- Keep hands and feet away from the conveyor intake and other moving parts.
- **NEVER** attempt to assist machinery operation or to remove trash from the equipment while in operation.
- Keep the area around intake free of obstacles that might trip workers.
- Components of this equipment have sharp edges which can scrape and/or cut an operator.
- A moving conveyor can sever an operator's limb or even kill.
- Always keep all shields and guards in place during operation.

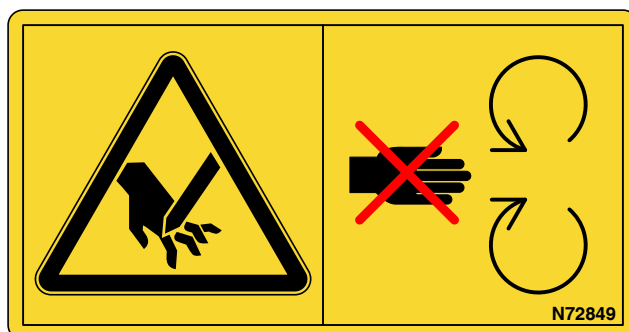

WARNING

AIRGUARD START UP PROCEDURE

For details on procedure visit airguardproducts.com

STEP 1 Turn **Airguard bypass** to '**HEAT OFF**' position.

STEP 2 Run hydraulics on Tractor and Air Cart until hydraulic oil temperature is **100-110 deg F**.

STEP 3 Set hydraulic flow to fans to '**OFF**' position in **TRACTOR**.

STEP 4 Turn **Airguard bypass** to '**HEAT ON**' position.

STEP 5 Set fans to 500 RPM (25% oil flow). Operate for **10 MINUTES** & Check for oil leaks.

STEP 6 Set fans to 1000 RPM (45% oil flow). Operate for 5 seconds.

STEP 7 Set fans to 2000 RPM (65% oil flow). Operate for 5 seconds.

STEP 8 Set fans to 3500 RPM (85-100% oil flow). Operate for **5 MINUTES**.

STEP 9 Ensure conveyor / auger is working properly. Set fans to 1200 RPM (50% oil flow) and run.

You're ready to operate!



AIRGUARD

Questions? Call AIRGUARD Sales Representative.

Safety

Safety Signs

Danger: Crushing Hazard

To prevent death or serious injury:

- Conveyor may fall rapidly causing bodily injury.
- Stand Clear - Of Conveyor when being raised, lowered or in elevated state.
- Ensure Cylinders are completely filled with hydraulic fluid to avoid unexpected movement.

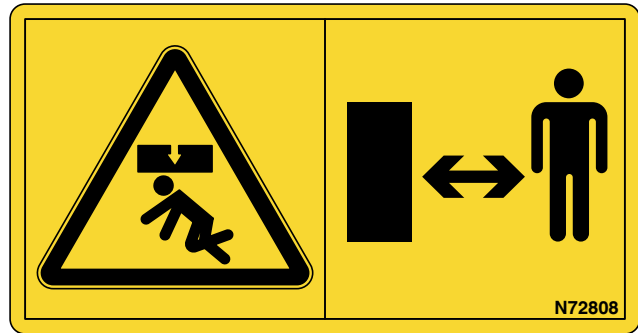

DANGER: Crush Hazard.

To prevent death or serious injury:

Exercise caution when manipulating conveyor, be aware of your surroundings and potential pinch points.

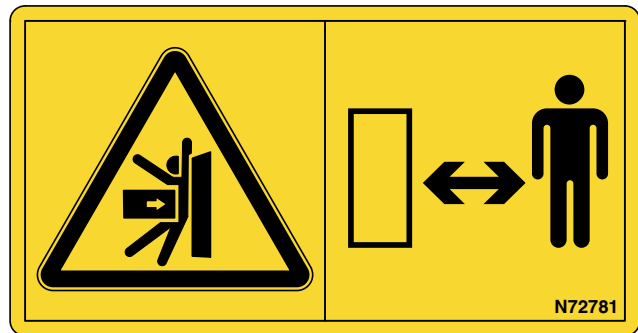

Warning: Loss of control hazard!

To prevent serious injury or death:

- Drive within the limits of road conditions and machine loading.
- Never exceed 30 km/h (20 mph) when towing the machine.

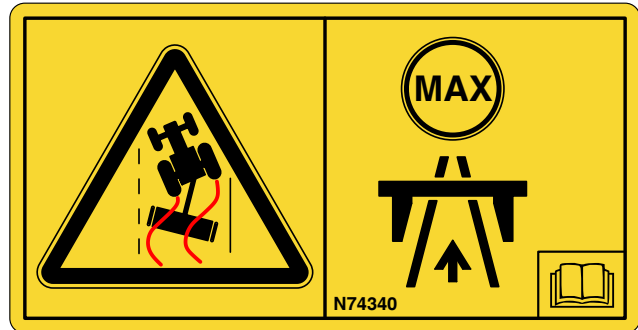

Warning: Before Servicing

To prevent serious injury or death:

- Stop the tractor and remove key, read the service specifications at the back of this manual.
- Use lock-out tags/procedures as required to prevent unanticipated machine operation.
- Do not operate with guard removed.
- Failure to comply could result in death or serious injury.

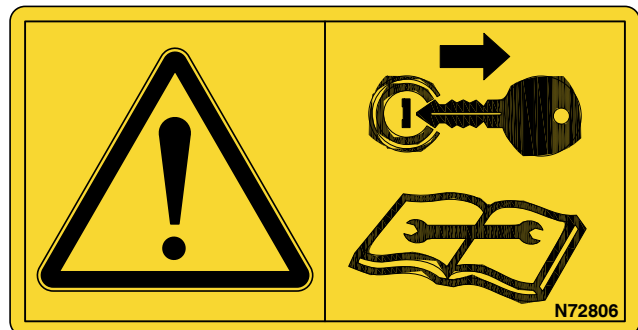

Familiarize yourself with the location of all decals. Read them carefully to understand the safe operation of your machine.

Safety Signs - Continued

Warning: No Riders

To prevent serious injury or death:

- Keep off while machine is moving or mechanism is running.

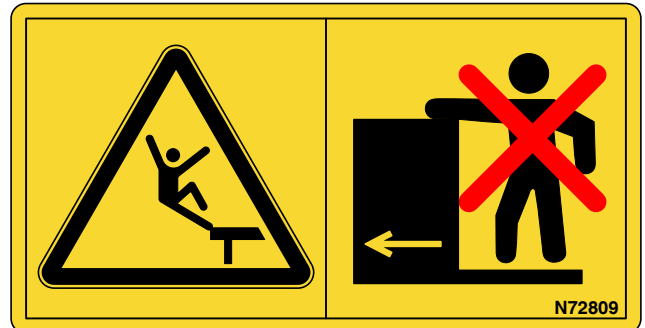

Warning: HIGH-PRESSURE FLUID HAZARD

To prevent serious injury or death:

- Relieve pressure on hydraulic system before servicing or disconnecting hoses.
- Wear proper hand and eye protection when searching for leaks. Use wood or cardboard instead of hands.
- Keep all components in good repair.
- Refer to tractor and implement Operator's Manuals service specifications.
- Use lock-out tags/procedures as required to prevent unanticipated machine operation.

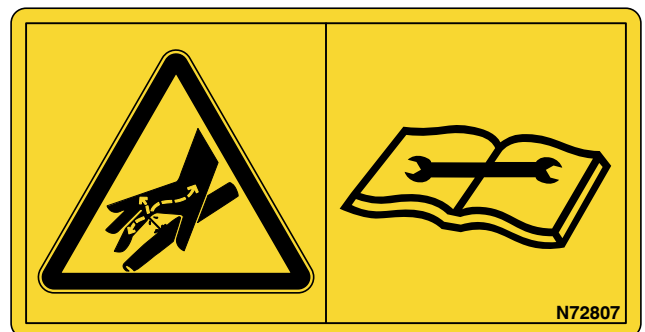

Caution: Avoid injury

Read and follow the instructions in this manual. Failure to comply could result in minor or moderate injury

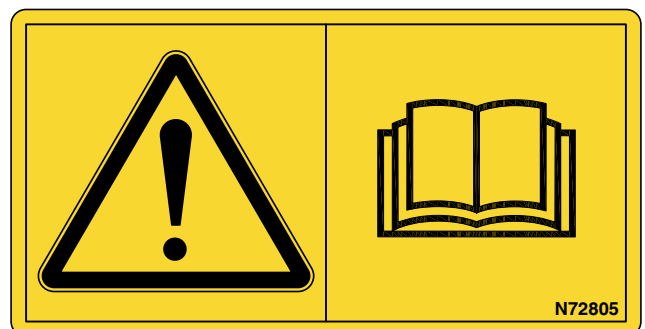

Familiarize yourself with the location of all decals. Read them carefully to understand the safe operation of your machine.

Safety

Safety Signs - Continued

Danger: Electrocutation Hazard

To prevent death or serious injury:

- This equipment is not insulated.
- Keep equipment away from overhead power lines and devices.
- Electrocutation can occur without direct contact.

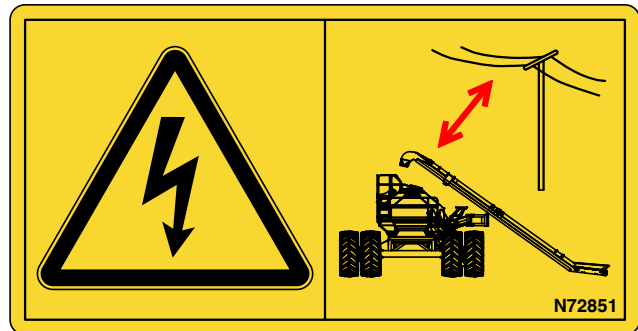

Danger: Electrical Hazard

To prevent death or serious injury:

- Shut tractor off and remove key before adjusting or servicing.
- Disconnect and lockout power source before adjusting or servicing. (Turn power OFF at the APU)
- Ensure all live connections are not receiving power.
- Use insulated tools whenever performing service to any electrical system or components.

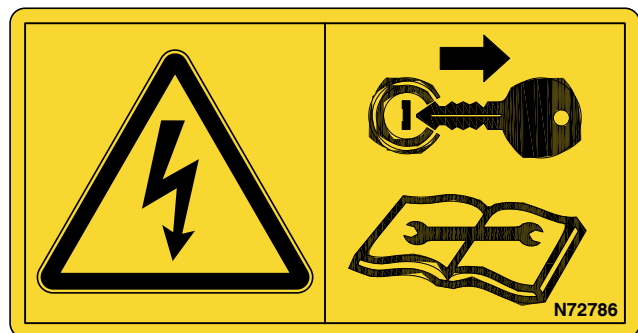

Warning: Burn Hazard

To prevent serious injury:

- Do not touch hydraulic motor or oil lines.
- Hydraulic motor and oil lines become extremely hot from operation.



Familiarize yourself with the location of all decals. Read them carefully to understand the safe operation of your machine.

Safety Signs - Continued

DANGER: Rotating Belt

To prevent serious injury or death:

- Stay away from intake end. Keep others away.
- Keep all shields in place.
- Keep hands, feet, hair and clothing away from belt.

Failure to comply will result in death or serious injury



Warning: Rotating parts (conveyor belts)

To prevent serious injury or death:

- Keep hand, feet, hair and clothing away from moving parts.
- Shut tractor off and remove key before adjusting or servicing.
- Use lock-out tags/procedures as required to prevent unanticipated machine operation.
- Do not operate with guards removed.



CAUTION: Rotating Part Hazard

To prevent serious injury or death:

- Keep hand, hair and clothing away from moving parts.
- Shut tractor off and remove key before adjusting or servicing.
- Disconnect and lockout power source before adjusting or servicing. (Turn power OFF at the APU)
- Meter Drives can start moving automatically without warning.



Familiarize yourself with the location of all decals. Read them carefully to understand the safe operation of your machine.

Safety

Safety Signs - Continued

Warning: Chemical Hazard

To prevent death or serious injury:

- Stop fan before opening lid. Do not operate fan with lid open. Avoid exposure to airborne chemicals.
- Dust and fumes will be exhausted if fan is operated with tank lid open. Chemicals may cause eye, skin or breathing problems.
- Wear face mask, gloves and goggles. Read and follow chemical suppliers safety instructions.

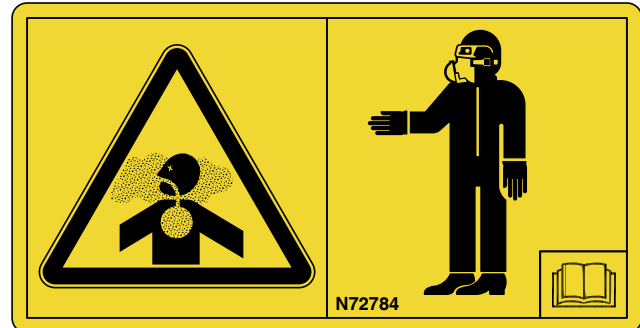

Caution: Tank is Pressurized

Pressurized tanks apply considerable force to lids.

Never open lids when pressurization fan is operating.

Failure to comply could result in minor or moderate injury.

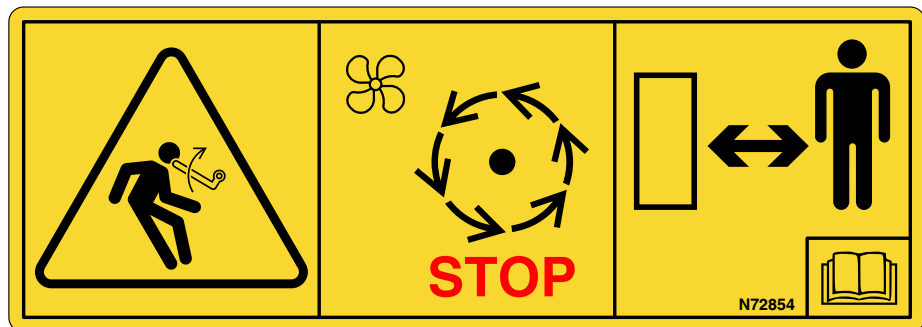

Warning: Entry Hazard

To prevent serious injury or death:

- **DO NOT ENTER** - No Ladder this hatch.



Familiarize yourself with the location of all decals. Read them carefully to understand the safe operation of your machine.

Safety Signs - Continued

Warning: Crushing Hazard

To prevent serious injury or death:

- Keep hands clear of conveyor arm linkage when moving conveyor.
- Shut tractor off and remove key before adjusting or servicing Conveyor.

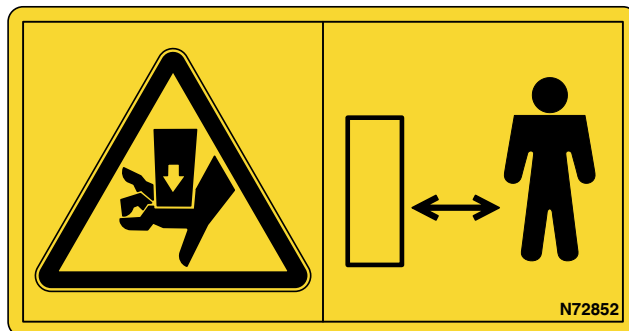

Caution: Hearing Loss

Avoid hearing loss, wear hearing protection when fans are operating. Failure to comply could result in minor to moderate injury.

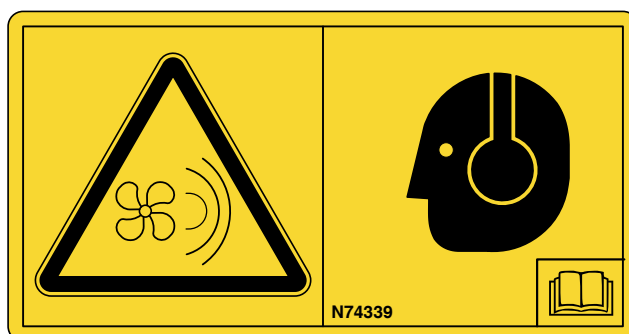

Decals

Part #	Description	QTY
Tanks		
N73677	Decal - Tank Size - 660 Cart	1
N72802	Decal - Tank Size - 820 Cart	1
N72804	Decal - Tank Size - 1050 Cart.....	1
N74469	Decal - Tank Size - 1440 Cart	1
N73676	Decal - 660	2
N72788	Decal - 820	2
N72789	Decal -1050	2
N74515	Decal -1440	2
N73169	Decal - MORRIS -Black - 6"	2
N73180	Decal - Stripe - 87"	2
N73181	Decal - Stripe - 42"	2
N73182	Decal - 10S - Right Side	1
N73183	Decal - 10S - Left Side.....	1
N73204	Decal - MORRIS -Red - 4"	2
N73903	Decal - Superior Farms Equipment	2
N74344	Decal - Optimizer Tank	1
N74345	Decal - Stripe - 34 1/4"	1



Familiarize yourself with the location of all decals. Read them carefully to understand the safe operation of your machine.

Safety

Safety Signs - Continued

Decals - Continued

Part #	Description	QTY
Frame		
11547	Patent - Pending	1
N45429	Decal - Patented	1
N55496	Decal - Patented	1
N50875	Decal - Conveyor Lock	1
N71105	Decal - Conveyor Arm Positions	1
N71125	Decal - Conveyor Gauge	2
N68512	ISO Decal - Burn Hazard.....	2
N72781	ISO Decal - Crush Hazard.....	2
N72782	Decal - OPEN/CLOSED	1 per meter body
N72783	Decal - Meter Number	2 per meter body
N72784	ISO Decal - Dust Hazard	2
N72785	ISO Decal - No Entry - No Ladder Do Not Enter	1
N72786	ISO Decal - Electrical Hazard.....	1
N72805	ISO Decal - Read Manual.....	1
N72806	ISO Decal - Turn Off Machine Before Servicing	1
N72807	ISO Decal - High Pressure Hazard.....	1
N72808	ISO Decal - Over Head Hazard	3
N72809	ISO Decal - No Riders	2
N72849	ISO Decal - Rotate Crush Hazard	2
N72850	ISO Decal - Rotate Hazard.....	1 per meter body
N72851	ISO Decal - Electrical Over Head Hazard	2
N72852	ISO Decal - Crushing Hazard.....	2
N72853	ISO Decal - Rotating Belt Hazard.....	1
N72854	ISO Decal - Tank Lid Pressure	1 per Lid
N72787	Decal - Collector Valve Position - Tow Between	1 per meter body
N73295	Decal - Collector Valve Position - Tow Behind	1 per meter body
N72797	Decal - Tank Shut-Off.....	1 per meter body
N72798	Decal - Seed Plate Setting.....	1 per meter body
N73179	Decal - APU Power	1
N73210	Decal - Tire Chart - 660, 820 and 1050.....	1
N75878	Decal - Tire Chart - 1440	1
N74298	Decal - Seed Plate Position	1
N74299	Decal - Speed Identification - 30 km/h - 200mm Diameter	1
N74902	Decal - Speed Identification - 20 mph - 200mm Diameter (USA only)	1
N34476	Reflector - Red.....	4
N34477	Reflector - Yellow.....	8
N34478	Reflector - Orange	4
N34475	SMV Sign.....	1

The following pages provide basic Decal Location information, for more details contact Morris' Customer Service.

Safety Signs - Continued

Front

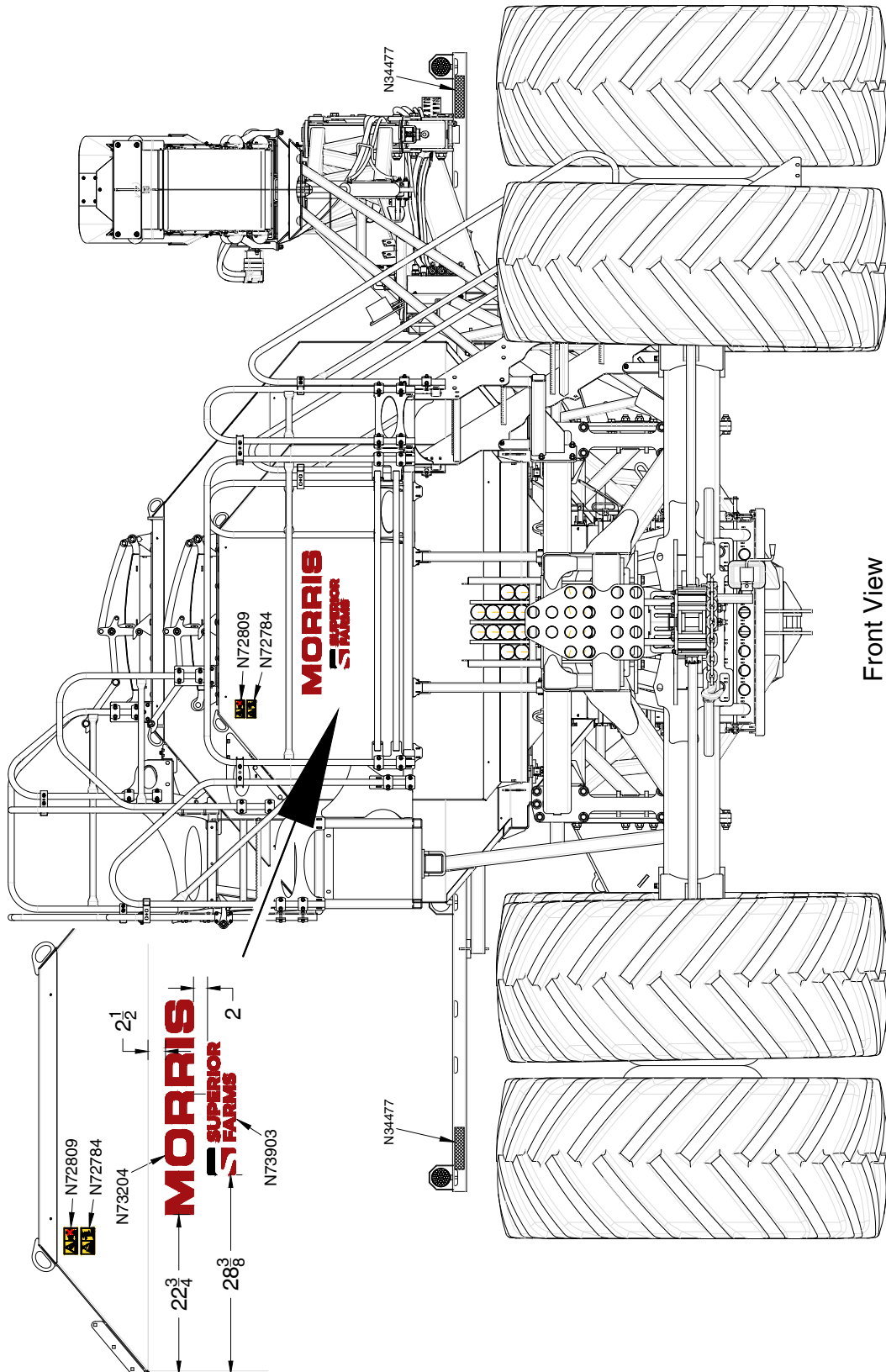

Safety

Safety Signs - Continued

Rear

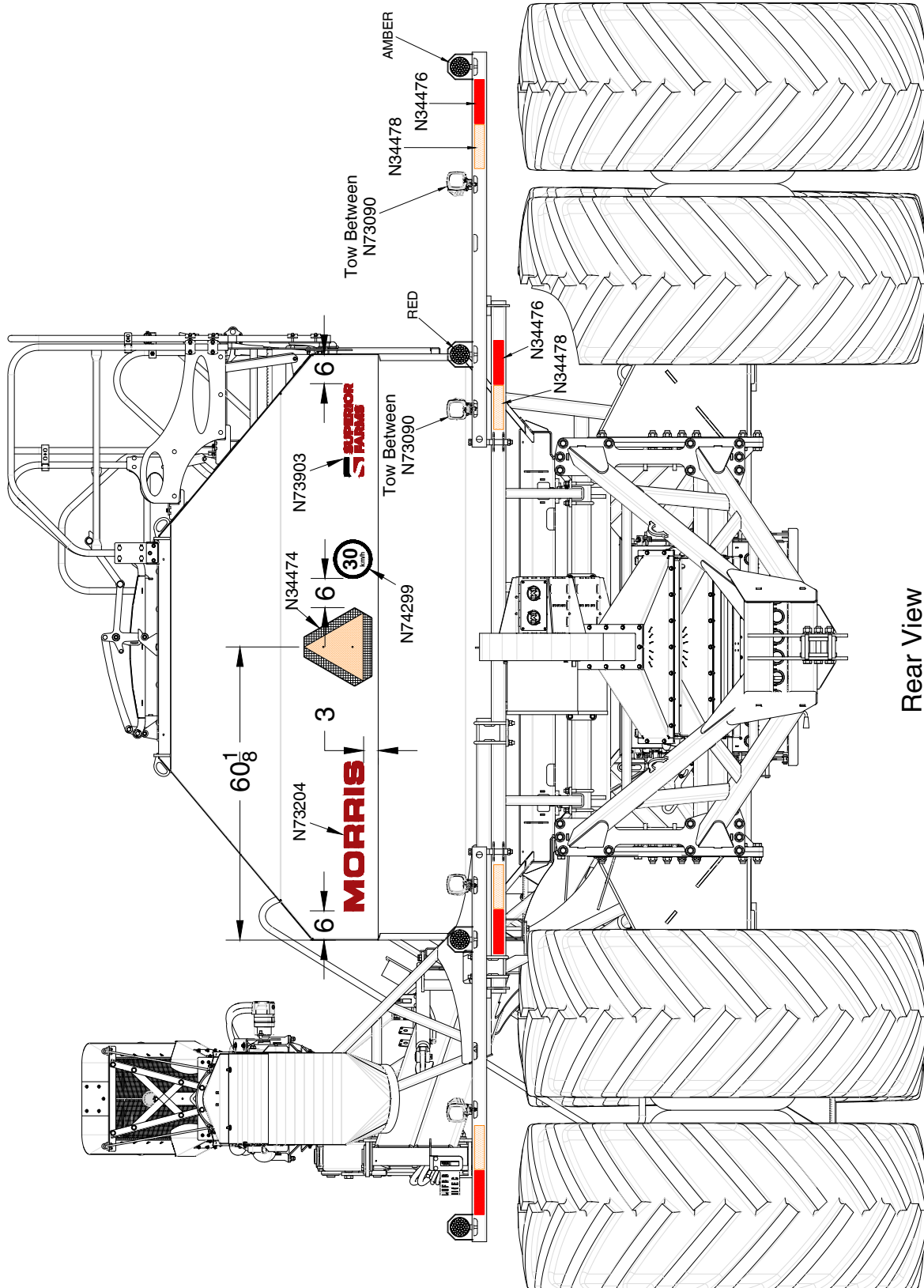

Safety Signs - Continued

Left Side - Tow Between

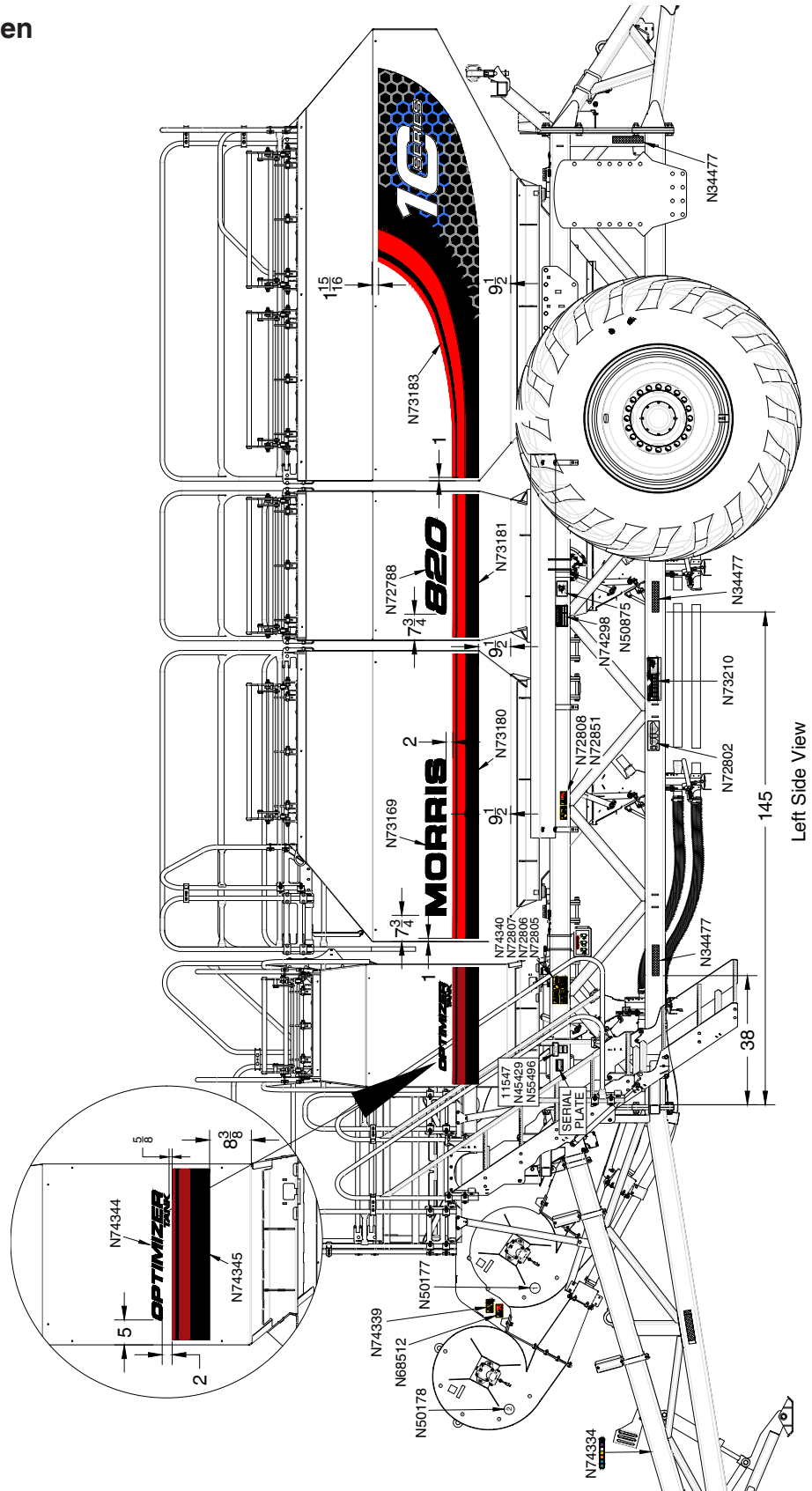

Safety

Safety Signs - Continued

Right Side - Tow Between

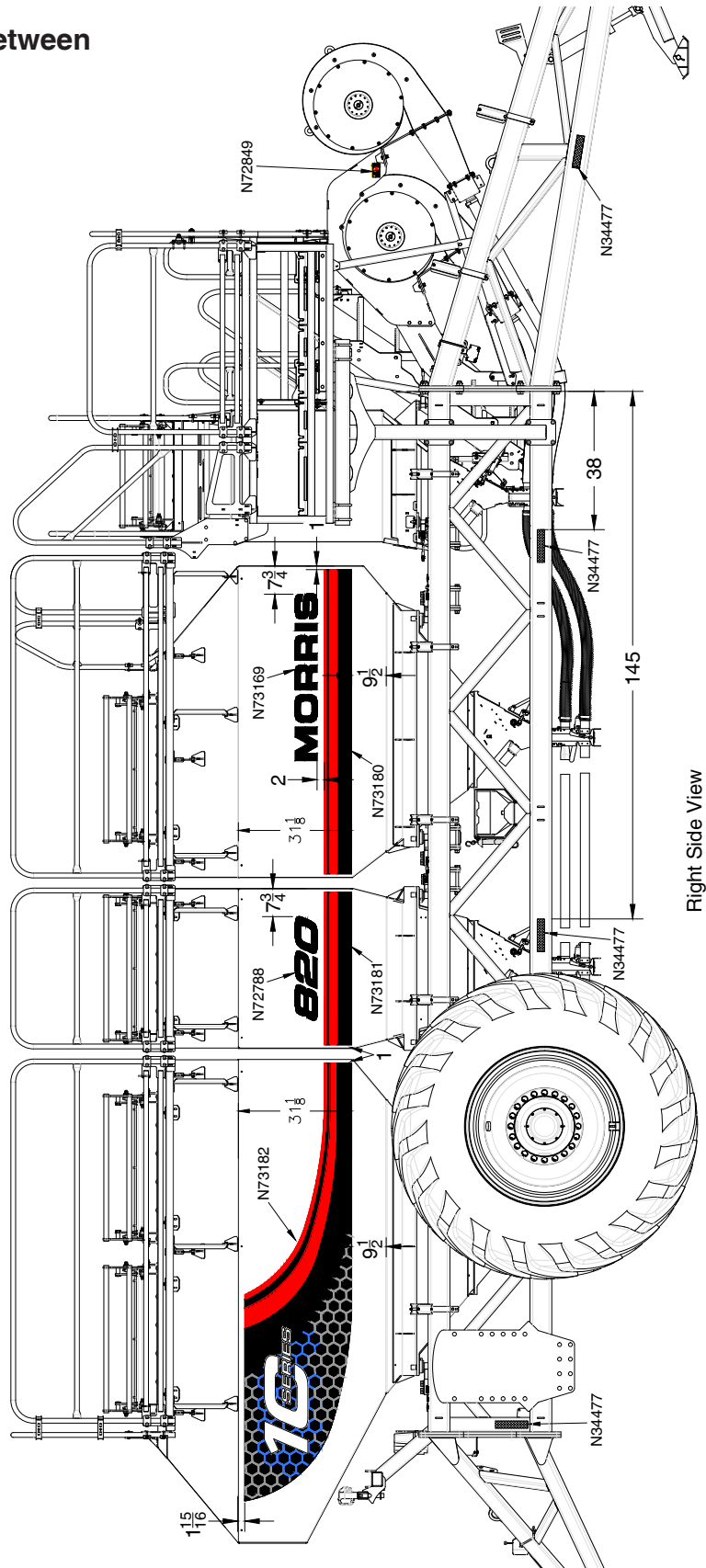

Right Side View

Safety

Safety Signs - Continued

Right Side - Tow Behind

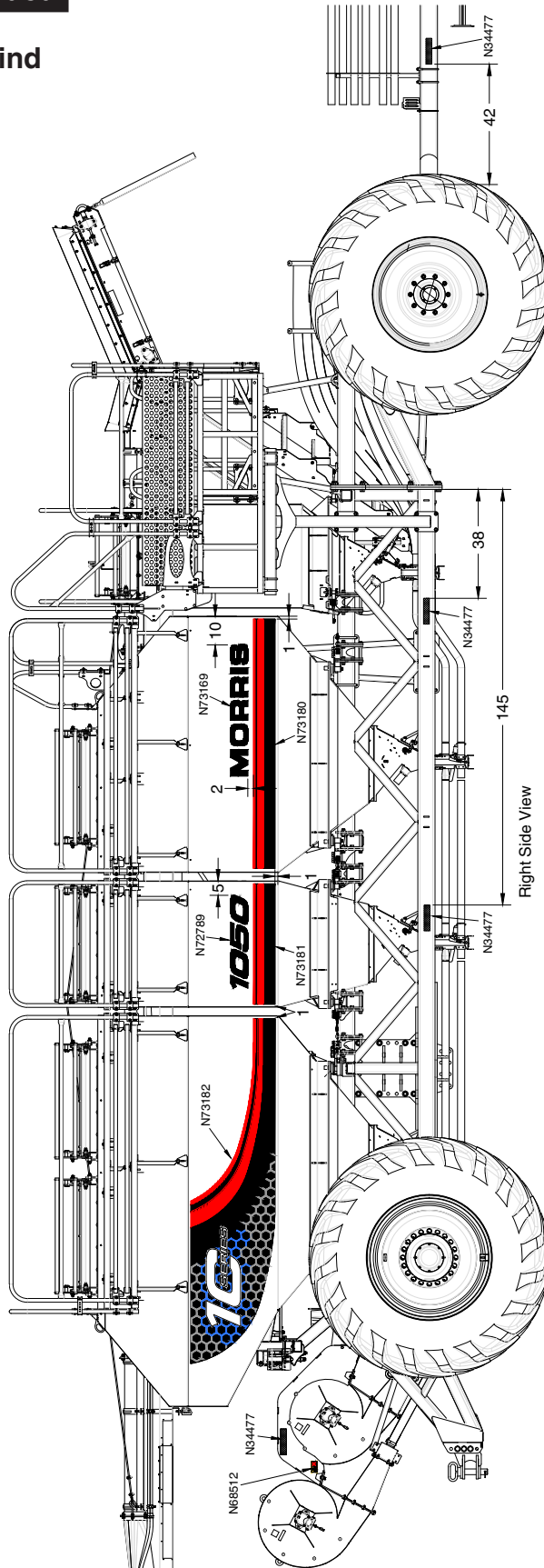

Safety Signs - Continued

Top

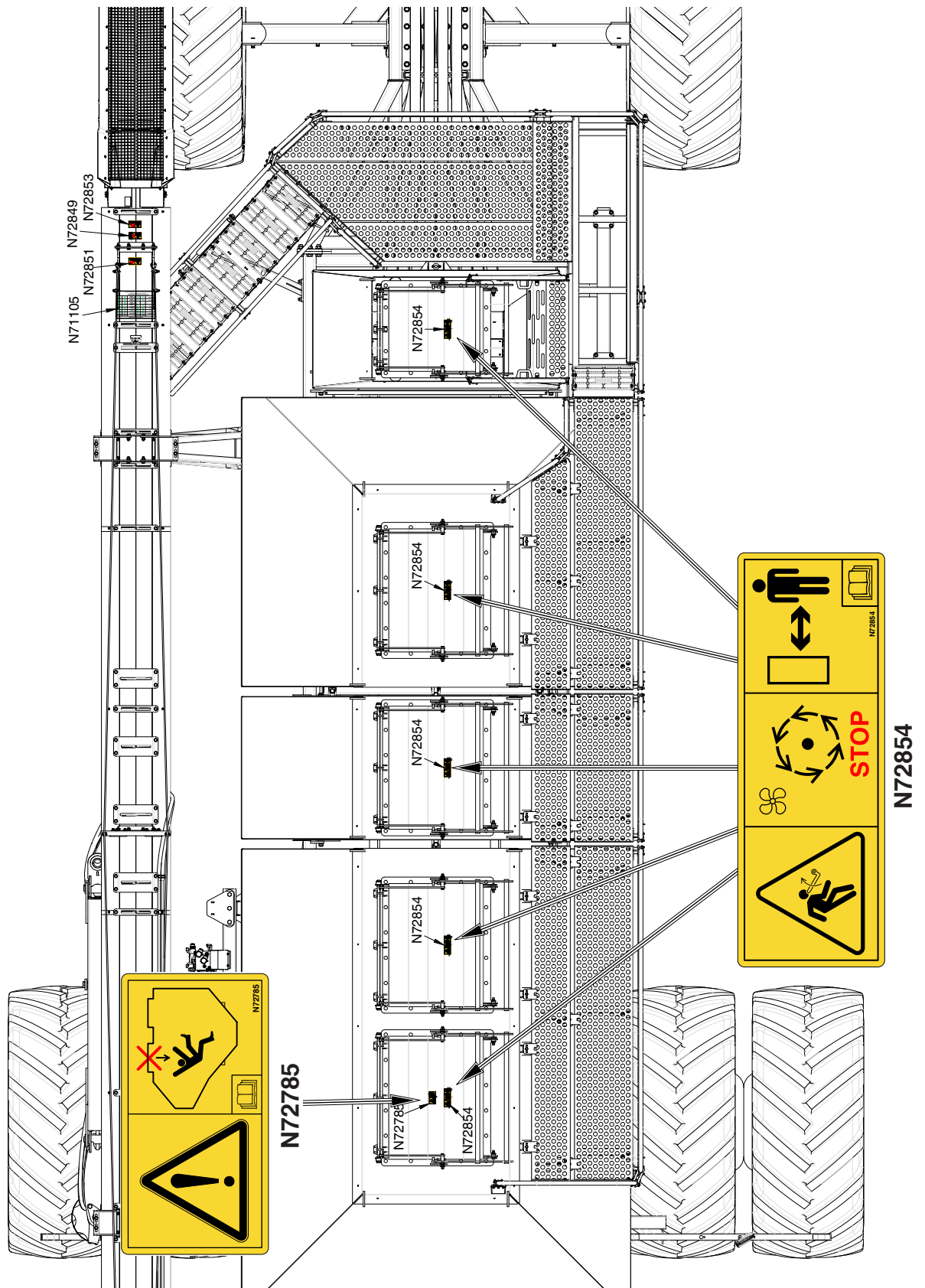

Safety

Safety Signs - Continued

ICT Meter Body

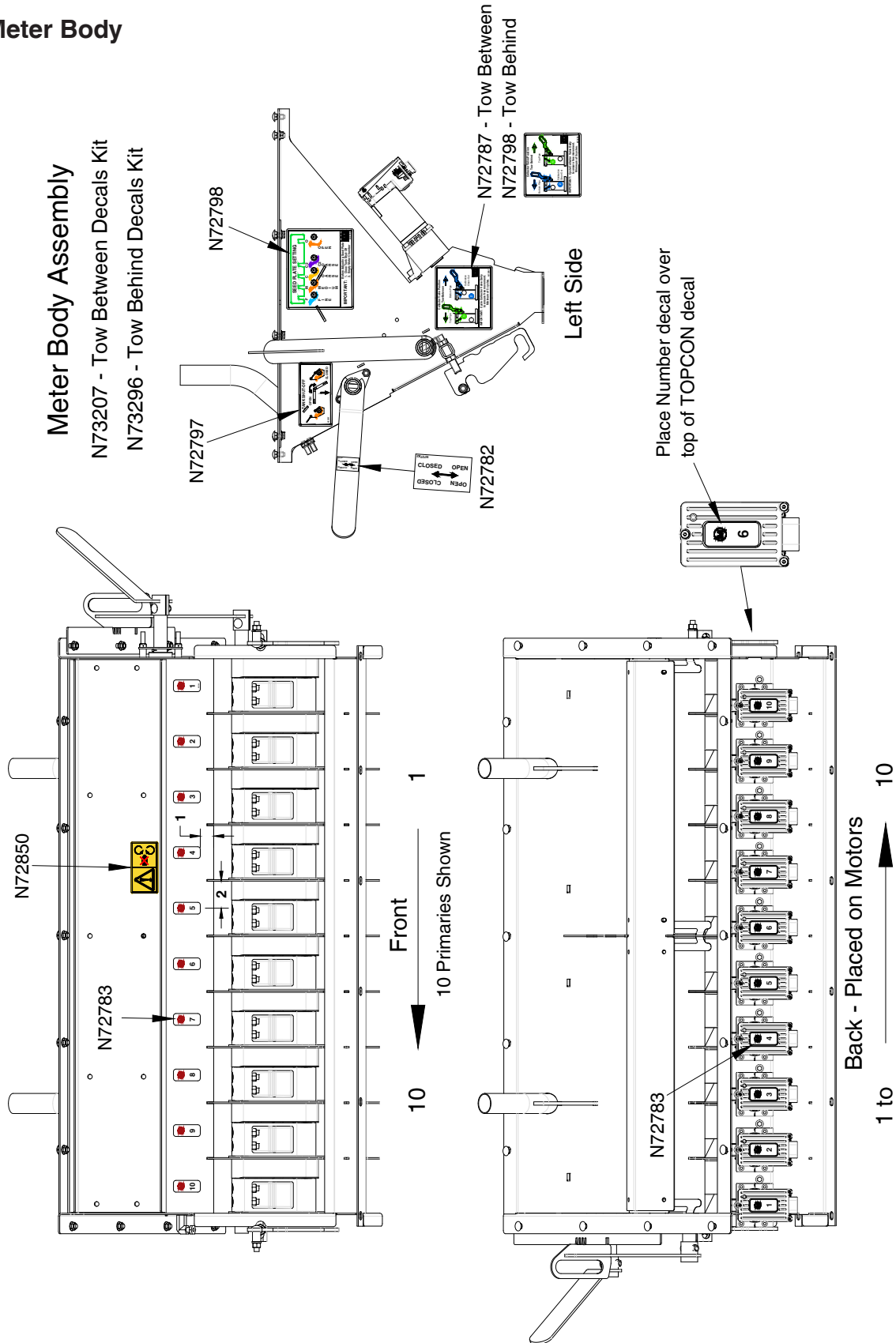

Safety Signs - Continued

Conveyor

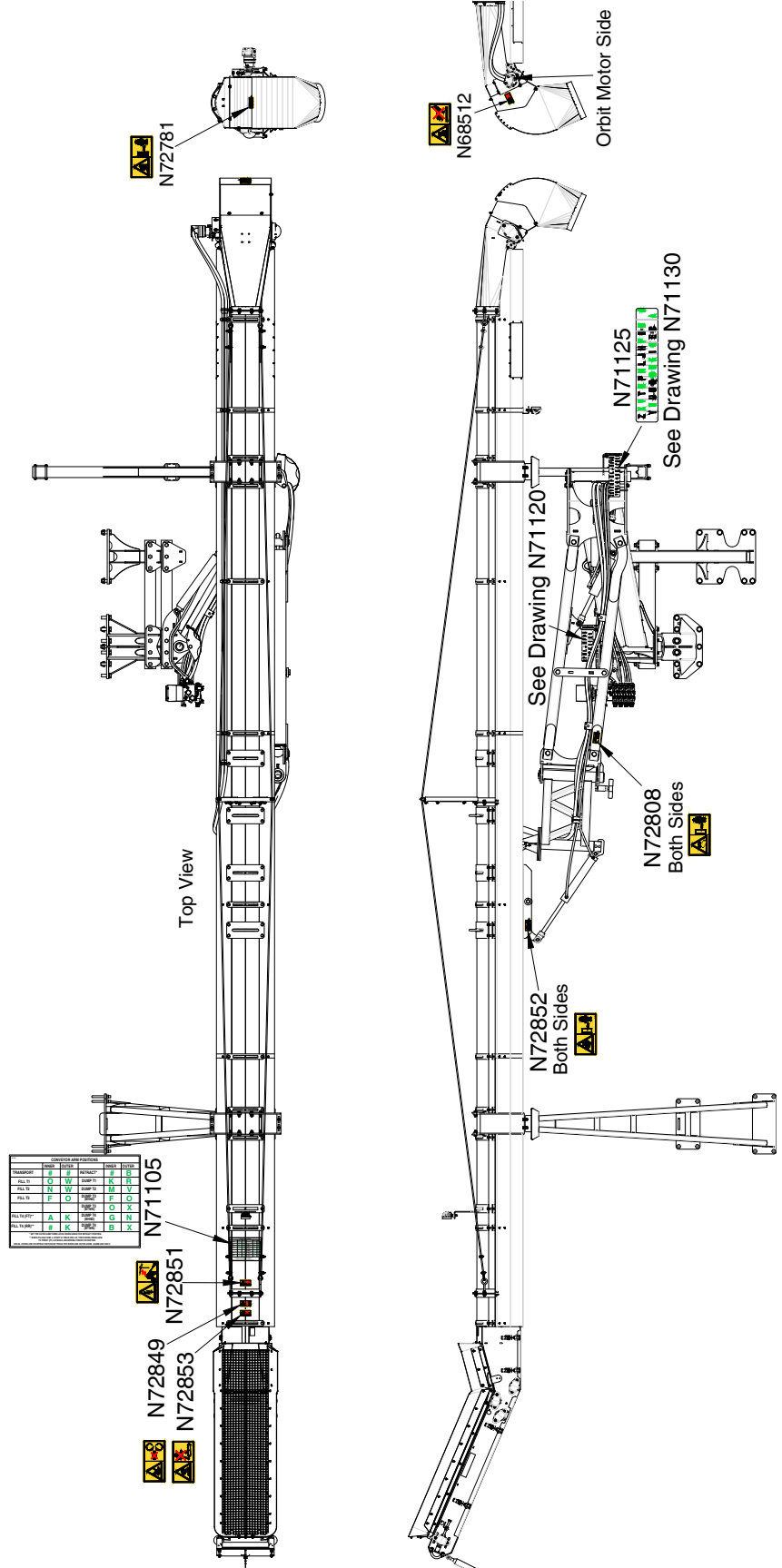

Safety

Lighting and Marking

MORRIS recommends the use of the correct lighting and marking to meet the ASAE standard for roadway travel. Be familiar with, and adhere to, local laws.

Amber warning and red taillights secured on the machine promote correct transportation of this implement.

Note: Always replace missing or damaged lights and/or connectors.

Amber warning and red taillights must be mounted to the rear of the implement and be visible from front and rear. The lights must be within 16 inches (41 cm) of the extremities of the machine and at least 39 inches (99 cm) but not over 10 feet (3 m) above ground level.

Note: Always replace missing or damaged front, side, rear reflectors and SMV emblem.



Tillage Unit

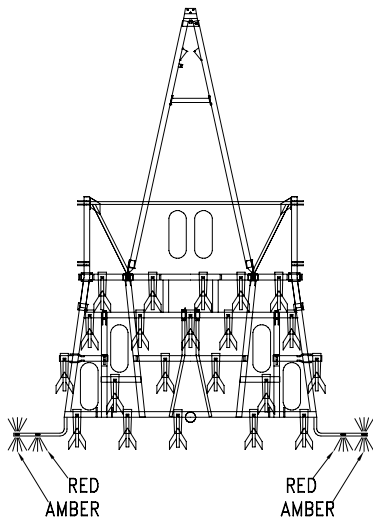

**Seeding Unit
Tow Between**

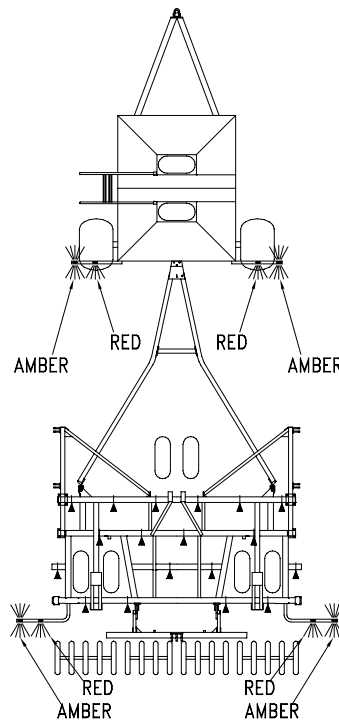

**Seeding Unit
Tow Behind**

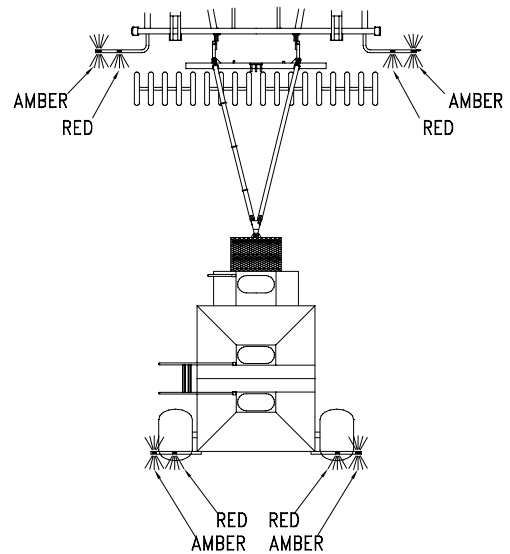

Section 2: Specifications

Section Contents

Dimensions.....	2-2
660, 820 and 1050 - Tow Between.....	2-4
660 and 820 - Tow Behind.....	2-5
1050 Cart - Tow Behind.....	2-6
1440 - Tow Behind.....	2-7

Specifications

Dimensions

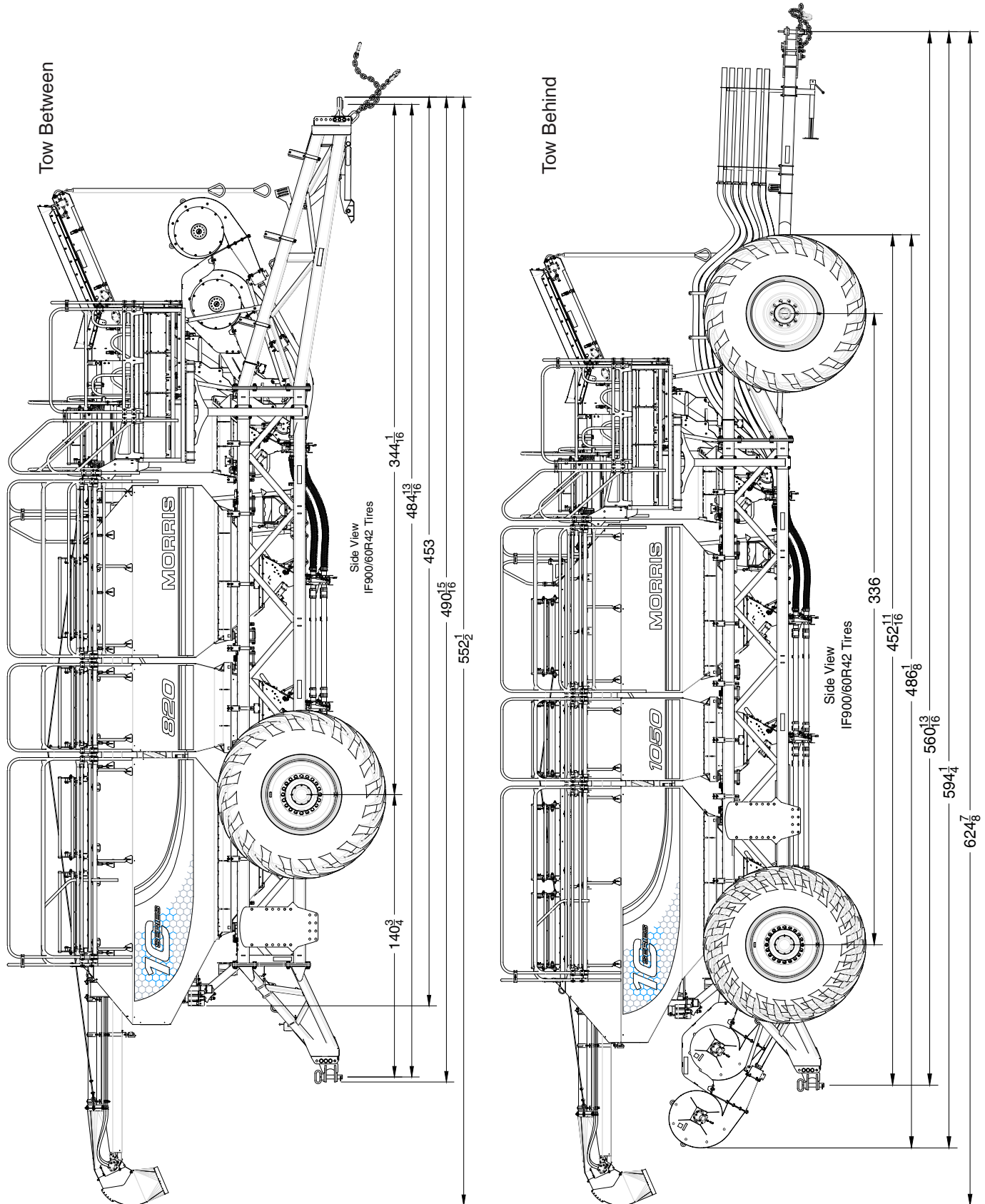

Dimensions - Continued

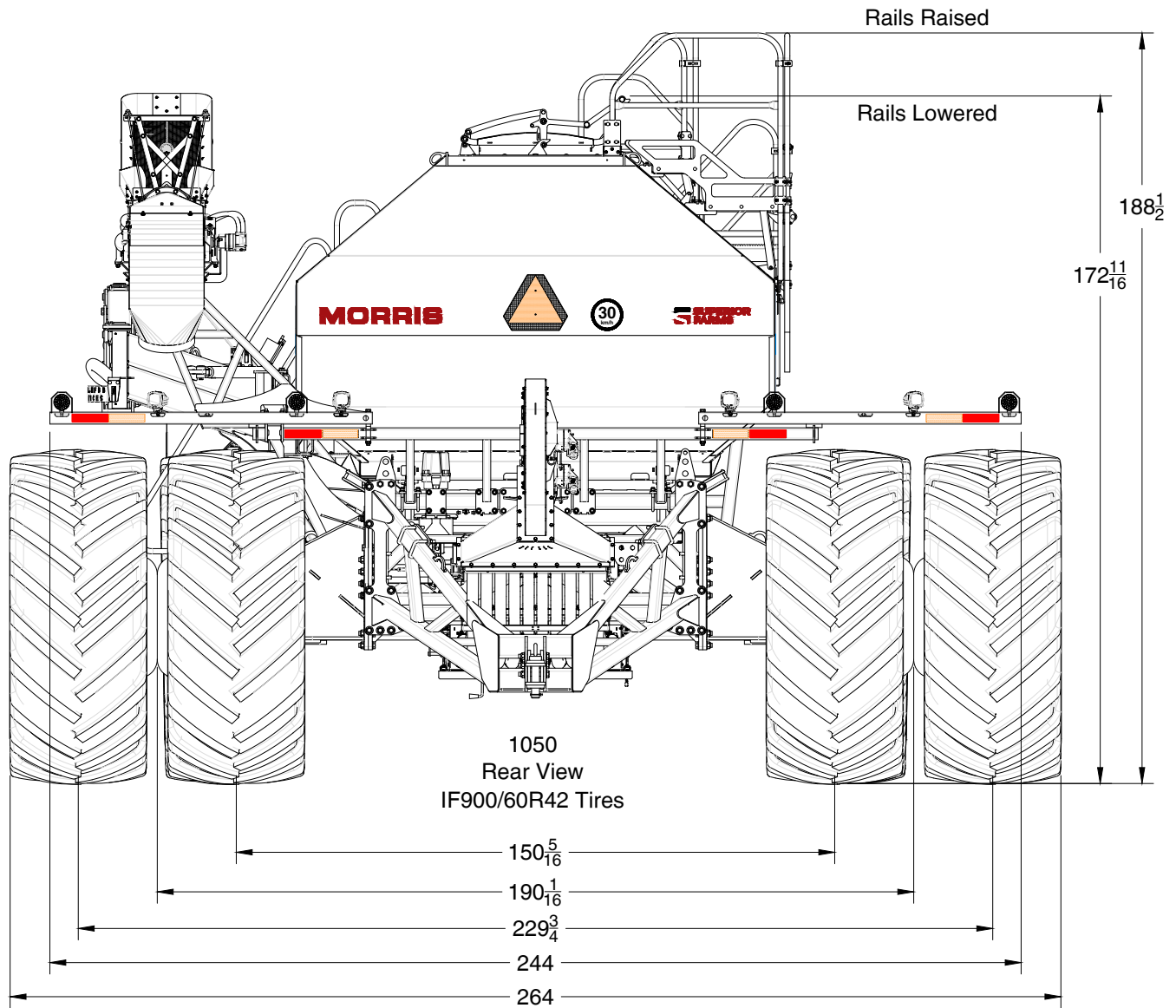

Specifications

660, 820 and 1050 - Tow Between Specifications and Options

Model	660	820	1050
Configuration	Tow Between	Tow Between	Tow Between
Length (with Conveyor) 553" (1405 cm) (Conveyor removed) (Conveyor and rear hitch removed) hitch to light bar	44' (13.41 m) 38' 11" (11.86 m) 35' 9" (10.90 m)	46' 1" (14.05 m) 40' 11" (12.47 m) 37' 9" (11.5 m)	46' 1" (14.05 m) 40' 11" (12.47 m) 37' 9" (11.5 m)
Height - Rails up (IF900/60R42 Tires) - Rails Lowered (IF900/60R42 Tires)	15' 8 1/2" (4.79 m) 14' 4 3/4" (4.39 m)	15' 8 1/2" (4.79 m) 14' 4 3/4" (4.39 m)	15' 8 1/2" (4.79 m) 14' 4 3/4" (4.39 m)
Width - Single Axle - VF800/70R38 CFO - Dual Axle - IF900/60R42 CFO	21' 9" (6.61m) N/A	21' 9" (6.61m) 22' (6.70 m)	N/A 22' (6.70 m)
Weight (Dual fans, 10 runs and conveyor)	34661 lbs (15722 kg)	37206lbs (16876 kg)	37769 lbs (17132 kg)
Tank Capacity - Tank 1 (Small Seeds) - Tank 2 - Tank 3 - Tank 4 - Total	60 bu (2114 l) 200 bu (7048 l) 130 bu (4581 l) 200 bu (7048 l) 590 bu (20791l)	80 bu (2819 l) 250 bu (8809 l) 175 bu (6166 l) 250 bu (8809 l) 755 bu (26605.5 l)	80 bu (2819 l) 330 bu (11628 l) 175 bu (6166 l) 465 bu (16386 l) 1050 bu (37,000 l)
Fan Impeller Diameter	22.8" (58 cm) - Up to 5,000 r.p.m.		
Hydraulic Drive - piston type orbit motor (Closed Centre or Closed Centre Load Sensing systems required) Hydraulic requirements for Air Cart only at Rated Fan Speed.	19cc - 25 U.S. gpm (95 lpm) at 3,100 psi (21,374 kPa) Dual Fans require 50 U.S. gpm (190 lpm) APU requires an additional 7.5 U.S. gal/min (28 lpm)		
Conveyor	Convey-All 35' x 10" Tube x 16" Belt 21 gpm (Flow Controlled)		
Tires Rear - 660 - 820 and 1050	Duals - (4) VF710/70R42 Distance Center-Center Inner 154" (391 cm) Distance Center-Center Outer 226" (574 cm) Duals - (4) IF or VF900/60R42 CFO Distance Center-Center Inner 151" (384 cm) Distance Center-Center Outer 230" (584 cm)		
Number Secondary Runs - Single Shoot	35 - 100		
Number Secondary Runs - Double Shoot	70 - 200		
Frame - Trussed	4" x 6" (10 cm x 15.2cm) tubing by 4" x 4" (10 cm x 10 cm) tubing		
Meter System Brushless Electric Meter Motors Variable Rate per Section Topcon Apollo with XD+ Console Primary Air System Weigh Scales Meter Wheels Same Side Tank Shut-Off/Seed Plate adjustment, with Quick Access Doors and easy clean-out system.	180w Standard Standard Standard 10 Run/2.5" Dia Stainless Steel Standard Each Tank Small Seeds(Tank 1) / Standard (Tanks 2,3,4) Standard		
Electrical System 24v Brushless Alternator 24v/12v Equalizer System Sealed ECU Module Undertank/Intank/Walkway/Conveyor Lighting Aux Tool Bar Lighting	150A Standard 24v-150A/12v-40A Standard 12K Lumens Standard 16K Lumens Standard		
Monitor Display Information Topcon XD+ Console	Fan speed, meter shafts, application rates, tank levels, ground speed, area seeded, individual section status (ICT), as-applied maps, VR layers, and packing force (optional).		
Rear Tow Hitch	Standard		
Hitch Jack - Hydraulic	Standard		
Hitch Clevis	Standard - Catagory 5		

Specifications

660 and 820 - Tow Behind Specifications and Options

Model	660	820
Configuration	Tow Behind	Tow Behind
Length (Hitch to Conveyor end) (Hitch to Dual Fan) (Hitch Removed)	50' (15.24 m) 47' 6" (14.48 m) 38' 4" (11.68 m)	52' 1" (15.875 m) 49' 6" (15.09 m) 40' 6" (12.34 m)
Height - Rails up (IF900/60R42 Tires) - Rails Lowered (IF900/60R42 Tires)	15' 8 1/2" (4.79 m) 14' 4 3/4" (4.39 m)	15' 8 1/2" (4.79 m) 14' 4 3/4" (4.39 m)
Width - Dual Axle - VF800/70R38 - 261" - Dual Axle - IF900/60R42 - 264"	21' 9" (6.61m) 22' (6.70 m)	21' 9" (6.61m) 22' (6.70 m)
Weight (Dual fans, 10 runs, 900/60R42 tires and conveyor)	40385 lbs (19739 kg)	43518 lbs (19585 kg)
Tank Capacity - Tank 1 (Small Seeds) - Tank 2 - Tank 3 - Tank 4 - Total	60 bu (2114 l) 200 bu (7048 l) 100 bu (3524 l) 300 bu (10572 l) 660 bu (23258 l)	80 bu (2819 l) 250 bu (8809 l) 135 bu (4757 l) 355 bu (12509 l) 820 bu (28896 l)
Tank Screens	N/A	
Fan Impeller Diameter	22.8" (58 cm) - Up to 5,000 r.p.m.	
Hydraulic Drive - piston type orbit motor (Closed Centre or Closed Centre Load Sensing systems required) Hydraulic requirements for Air Cart only at Rated Fan Speed.	19cc - 25 U.S. gpm (95 lpm) at 3,100 psi (21,374 kPa) Dual Fans require 50 U.S. gpm (190 lpm) APU requires an additional 7.5 U.S. gal/min (28 lpm)	
Conveyor	Convey-All 35' x 10" Tube x 16" Belt 21 gpm (Flow Controlled)	
Tires Front - Option 1 - Option 2	(2) VF710/70R42 Distance Center-Center Inner 154" (391 cm) (2) IF or VF900/60R42 CFO Distance Center-Center 151" (384 cm)	
Tires Rear - Option 1 - Option 2	Duals - (4) VF710/70R42 Distance Center-Center Inner 154" (391 cm) Distance Center-Center Outer 226" (574 cm) Duals - (4) IF or VF 900/60R42 CFO Distance Center-Center Inner 151" (384 cm) Distance Center-Center Outer 230" (584 cm)	
Number Secondary Runs - Single Shoot	35 - 100	
Number Secondary Runs - Double Shoot	70 - 200	
Frame - Trussed	4" x 6" (10 cm x 15.2cm) tubing by 4" x 4" (10 cm x 10 cm) tubing	
Meter System Brushless Electric Meter Motors Variable Rate per Section Topcon Apollo with XD+ Console Primary Air System Weigh Scales Meter Wheels Same Side Tank Shut-Off/Seed Plate adjustment, with Quick Access Doors and easy clean-out system.	180w Standard Standard Standard 10 Run/2.5" Dia Stainless Steel Standard Each Tank Small Seeds(Tank 1) / Standard (Tanks 2,3,4) Standard	
Electrical System 24v Brushless Alternator 24v/12v Equalizer System Sealed ECU Module Undertank/Intank/Walkway/Conveyor Lighting Aux Tool Bar Lighting	150A Standard 24v-150A/12v-40A Standard 12K Lumens Standard 16K Lumens Standard	
Monitor Display Information Topcon XD+ Console	Fan speed, meter shafts, application rates, tank levels, ground speed, area seeded, individual section status (ICT), as-applied maps, VR layers, and packing force (optional).	
Rear Tow Hitch	Optional	
Hitch Jack - Manual	Standard	
Hitch Clevis	Standard - Catagory 5	

Specifications

1050 Cart - Tow Behind Specifications and Options

Model	1050
Configuration	Tow Behind
Length (Hitch to Conveyor end) (Hitch to Dual Fan) (Hitch Removed)	52' 1" (15.875 m) 49' 6" (15.09 m) 40' 6" (12.34 m)
Height - Rails up (IF900/60R42 Tires) - Rails Lowered (IF900/60R42 Tires)	15' 8 1/2" (4.79 m) 14' 4 3/4" (4.39 m)
Width - Dual Axle - IF900/60R42 - 264"	22' (6.70 m)
Weight (Dual fans, 10 runs, 900/60R42 tires and conveyor)	44130 lbs (20017kg)
Tank Capacity - Tank 1 - Small Seeds	80 bu (2819 litres)
- Tank 2 - Front	330 bu (11628 litres)
- Tank 3 - Middle	175 bu (6166 l)
- Tank 4 - Back	465 bu (16386 l)
- Total	1050 bu (37,000 l)
Tank Screens	N/A
Fan Impeller Diameter	22" (56 cm) - Up to 5,000 r.p.m.
Hydraulic Drive - piston type orbit motor (Closed Centre or Closed Centre Load Sensing systems required) Hydraulic requirements for Air Cart only at Rated Fan Speed.	19cc - 25 U.S. gpm (95 lpm) at 3,100 psi (21,374 kPa) Dual Fans require 50 U.S. gpm (190 lpm) APU requires an additional 7.5 U.S. gal/min (28 lpm)
Conveyor	Convey-All 35' x 10" Tube x 16" Belt 21 gpm (Flow Controlled)
Tires - Front	(2) VF900/60R42 CFO Distance Center-Center 151" (384 cm)
- Rear	Duals - (4) VF900/60R42 CFO Distance Center-Center Inner 151" (384 cm) Distance Center-Center Outer 230" (584 cm)
Number Secondary Runs - Single Shoot	35 - 100
Number Secondary Runs - Double Shoot	70 - 200
Frame - Trussed	4" x 6" (10 cm x 15.2cm) tubing by 4" x 4" (10 cm x 10 cm) tubing
Meter System Brushless Electric Meter Motors Variable Rate per Section Topcon Apollo with XD+ Console Primary Air System Weigh Scales Meter Wheels Same Side Tank Shut-Off/Seed Plate adjustment, with Quick Access Doors and easy clean-out system.	180w Standard Standard Standard 10 Run/2.5" Dia Stainless Steel Standard Each Tank Small Seeds (Tank 1) / Standard (Tanks 2,3,4) Standard
Electrical System 24v Brushless Alternator 24v/12v Equalizer System Sealed ECU Module Undertank/Intank/Walkway/Conveyor Lighting Aux Tool Bar Lighting	150A Standard 24v-150A/12v-40A Standard 12K Lumens Standard 16K Lumens Standard
Monitor Display Information Topcon XD+ Console	Fan speed, meter shafts, application rates, tank levels, ground speed, area seeded, individual section status (ICT), as-applied maps, VR layers, and packing force (optional).
Rear Tow Hitch	Optional
Hitch Jack - Manual	Standard
Hitch Clevis	Standard - Category 5

Specifications

1440 - Tow Behind Specifications and Options

Model	1440
Configuration	Tow Behind
Length (Hitch to Conveyor end) (Hitch to Dual Fan) (Hitch Removed)	56' 6" (17.22 m) 49' 6" (15.09 m) 40' 6" (12.34 m)
Height - Rails up	17' 9" (5.41 m)
- Rails Lowered	16' 5 1/4" (5.01 m)
Width - Dual Axle - IF850/60R42 CFO - 265"	22' 1" (6.70 m)
Weight (Dual fans, 10 runs and conveyor)	54490 lbs (24716 kg)
Tank Capacity - Tank 1 - Small Seeds	110 bu (3876 litres)
- Tank 2 - Front	450 bu (15858 litres)
- Tank 3 - Middle	235 bu (8281 l)
- Tank 4 - Back	645 bu (22729 l)
- Total	1440 bu (50744 l)
Tank Screens	N/A
Fan Impeller Diameter	22" (56 cm) - Up to 5,000 r.p.m.
Hydraulic Drive - piston type orbit motor (Closed Centre or Closed Centre Load Sensing systems required) Hydraulic requirements for Air Cart only at Rated Fan Speed.	19cc - 25 U.S. gpm (95 lpm) at 3,100 psi (21,374 kPa) Dual Fans require 50 U.S. gpm (190 lpm) APU requires an additional 7.5 U.S. gal/min (28 lpm)
Conveyor	Convey-All 40' x 14" Tube x 22" Belt 21 gpm (Flow Controlled)
Tires - Front	Duals - (4) VF710/70R42 CFO Distance Center-Center Inner 155" (394 cm) Distance Center-Center Outer 228" (579 cm)
- Rear	Duals - (4) IF850/75R42 CFO Distance Center-Center Inner 150" (381 cm) Distance Center-Center Outer 231" (587 cm)
Number Secondary Runs - Single Shoot	35 - 100
Number Secondary Runs - Double Shoot	70 - 200
Frame - Trussed	4" x 6" (10 cm x 15.2cm) tubing by 4" x 4" (10 cm x 10 cm) tubing
Meter System Brushless Electric Meter Motors Variable Rate per Section Topcon Apollo with XD+ Console Primary Air System Weigh Scales Meter Wheels Same Side Tank Shut-Off/Seed Plate adjustment, with Quick Access Doors and easy clean-out system.	180w Standard Standard Standard 10 Run/2.5" Dia Stainless Steel Standard Each Tank Small Seeds (Tank 1) / Standard (Tanks 2,3,4) Standard
Electrical System 24v Brushless Alternator 24v/12v Equalizer System Sealed ECU Module Undertank/Intank/Walkway/Conveyor Lighting Aux Tool Bar Lighting	150A Standard 24v-150A/12v-40A Standard 12K Lumens Standard 16K Lumens Standard
Monitor Display Information Topcon XD+ Console	Fan speed, meter shafts, application rates, tank levels, ground speed, area seeded, individual section status (ICT), as-applied maps, VR layers, and packing force (optional).
Rear Tow Hitch	Optional
Hitch Jack - Manual	Standard
Hitch Clevis	Standard - Catagory 5

Specifications

Notes

Section 3: Checklist

Section Contents

Manuals	3-2
Parts Manual	3-2
Checklist	3-3

Checklist

SAFETY-ALERT SYMBOL



Watch for this symbol. It identifies potential hazards to health or personal safety. It points out safety precautions. It means:

**ATTENTION - BE ALERT.
Your safety is involved.**

Manuals

Note: Pre-Delivery Inspection Form must be completed and submitted to Morris Equipment within 30 days of delivery date.

Warranty Void if Not Registered

Parts Manual Order Part Number N72799

Assembly Manual Order Part Number N72801

Checklist

Please read the Operator's Manual carefully and become a "SAFE" operator.

Adopt a good lubrication and maintenance program.

General

- ___ Check if assembled correctly.
- ___ Check wire connections.
- ___ Check hose connections.
- ___ Ensure cleanout door and tank lid are connected correctly.

Lubrication - Grease

- ___ Hub Bearings
- ___ Front Axle Pivots
- ___ Conveyor Pivots

Tire Pressure

- ___ See Maintenance, Section 7.

Transport

- ___ Lock-up pins must be in place.
- ___ Brakes connected and operational.
- ___ Tighten wheel bolts.
- ___ Check hose connections.

OWNER REFERENCE

Model: _____
Serial No: _____
Dealer: _____
Town: _____ State: _____
Phone: _____
OWNER/OPERATOR _____
Date: _____



TAKE SAFETY SERIOUSLY.

**DO NOT TAKE
NEEDLESS CHANCES!!**

Checklist

Notes

Section 4: Introduction

Section Contents

Introduction.....	4-2
Features	4-3
Topcon XD+ 12.1 Console	4-3
Morris Electric Drive System	4-4
Metering System	4-5
Convenient Adjustments	4-6
Hydraulic Conveyor	4-6
High Capacity Fans	4-7
Weigh Scale	4-7

Introduction

Introduction

This Operator's Manual has been carefully prepared to provide the necessary information regarding the operation and adjustments, so that you may obtain maximum service and satisfaction from your new MORRIS 10 Series Air Cart.

To protect your investment, study your manual before starting or operating in the field. Learn how to operate and service your 10 Series Air Cart correctly, failure to do so could result in personal injury or equipment damage.

If you should find that you require information not covered in this manual, contact your local MORRIS Dealer. The Dealer will be glad to answer any questions that may arise regarding the operation of your MORRIS 10 Series Air Cart.

MORRIS Dealers are kept informed on the best methods of servicing and are equipped to provide prompt efficient service if needed.

Occasionally, your 10 Series Air Cart may require replacement parts. Your Dealer will be able to supply you with the necessary replacement parts required. If the Dealer does not have the necessary part, the MORRIS Factory will supply the Dealer with it promptly.

Your MORRIS 10 Series Air Cart is designed to give satisfaction even under difficult conditions. A small amount of time and effort spent in protecting it against rust, wear and replacing worn parts will increase the life and trade-in value.



Keep this book handy for ready reference at all times. It is the policy of Morris Equipment Ltd. to improve its products whenever it is possible to do so. The Company reserves the right to make changes or add improvements at any time without incurring any obligation to make such changes on machines sold previously.

Features

Topcon XD+ 12.1 Console

This monitoring system that has a wealth of capabilities for precision ag activities. Full touch-screen navigation built for fast and efficient movement through the system.

Key capabilities include full variable rate monitoring readouts (customizable), full operation for overlap control, tank scales with calibration correction on the go, per section prescription application, specific job monitoring, pack force and drill control, implement-specific presets and full interface screen view customization.

This monitor perform many functions, most importantly, it can fully operate the overlap control that will give you a realtime field view of your cost savings.

Topcon XD+ Console features:

12.1in color touchscreen display.

Topcon H5 Electric Drive Software embedded.

Remote Support Tool, allowing technicians to remotely diagnose and fix issues.

Horizon XTend displays any view/window on virtually any mobile device.

GNSS standard when tied with SGR-1/AGI-4 Receivers.

Auto section control (ASC) up to 200 sections via ISOBUS.

Variable rate control (VRC) up to 8 products.

ISOBUS features UT, TC-BAS, TC-GEO and TC-SC.

Up to 2 Cameras connected through XD+.

This monitor can pair with a Tablet or Smart Phone to the XD+ for remote calibration or use the phone as a hot spot for Morris Service technicians to log into the device remotely for trouble shooting.



Introduction

Features - Continued

Morris Electric Drive System

- Able to control 10 granular sections per tank (40 total motors) with variable rate per section.
- Auxiliary Power Module (APU) with hydraulic motor and alternator to generate required 24vDC power for drive motors and accessory power (12vDC) is available for lighting system and conveyor.
- Load cells on each tank (3) allow for precise product weighing and potential to use calibration correction on the go in the field to monitor and adjust calibration factors in-field.
- Brushless CAN BUS motors offer long life compared to competitive brushed motors.

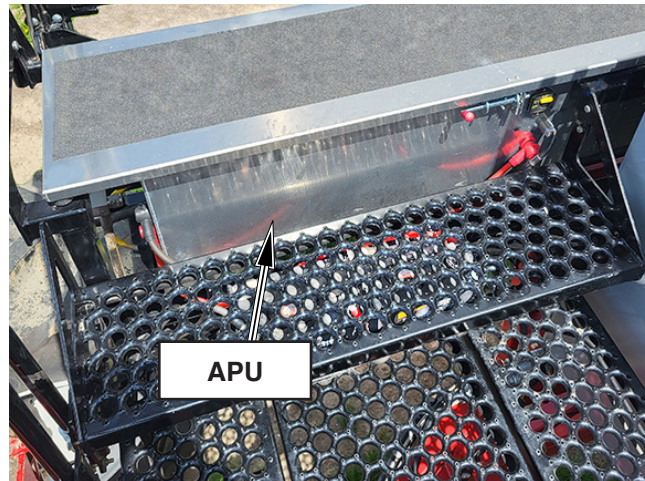

Apollo CM-40 E-Drive

Features:

Specifically dedicated to electric drive system.

Monitoring of:

- Motor speed and torque, motor stall/rotor lock condition.
- Tank Pressure Sensors.
- Collector Diverter Position Sensor (Top/Bottom Air Stream).
- Fan Shaft Speeds Sensors.
- Scale Link tank scales (UT).



CM-40 E-Drive

Features - Continued

Metering System

Gear Box

A 40:1 worm drive gear box with sealed housing and stainless steel output shaft connects the electric motor to the metering wheel.

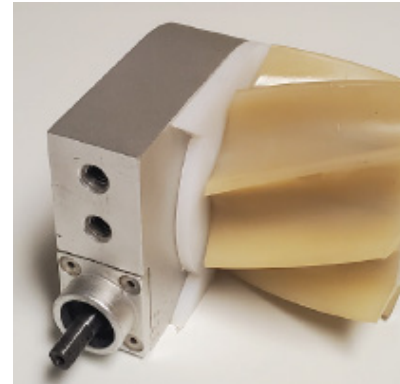

Spiral Fluted Metering Wheel - 2.5 Wide

The spiral fluted metering wheel is a Morris staple – its continuous flow of product into the air stream is the gold-standard in metering accuracy.

Rate range: 20-300 lb/ac. (22 kg/ha-336 kg/ha)

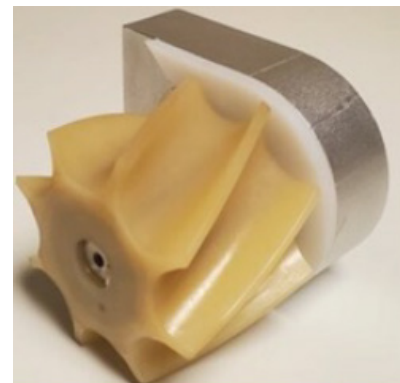

Spiral Fluted Metering Wheel - 1.75 Wide

This metering wheel is used in the Optimizer Tank™, delivers outstanding low-rate flow of product into the air stream.

Rate range: 4-190 lb/ac. (4.5 kg/ha-212 kg/ha)

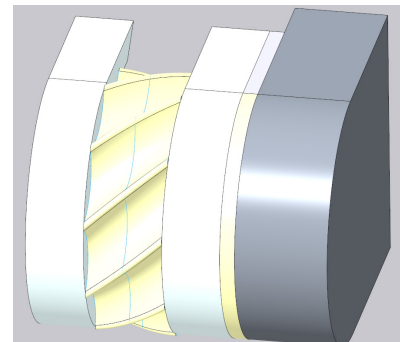

Spiral Fluted Metering Wheel - 1.0 Wide

This metering wheel is used in the Optimizer Tank™, delivers outstanding low-rate flow of product into the air stream.

Rate range: 2-70 lb/ac. (2 kg/ha-78 kg/ha)

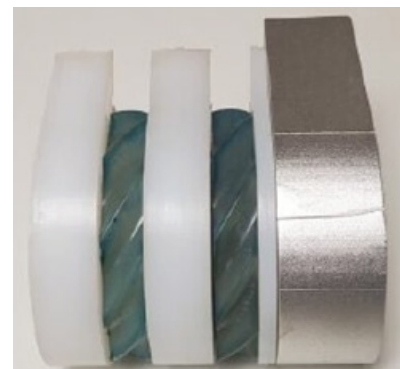

Dual Spiral Fluted Metering Wheel - 0.5 Wide

This metering wheel is used in the Optimizer Tank™, delivers outstanding low-rate flow of product into the air stream.

Rate range: 1-50 lb/ac (1 kg/ha-56 kg/ha)

Introduction

Features - Continued

Convenient Adjustments

All functions for the cart systems are on the left hand side of the air cart.

- Inspection Door Lever
- Tank Shut-Off Lever
- Seed Plate Adjustment Level
- Cleanout/Calibration Door Lever
- Light and conveyor switch box
- Access stairway

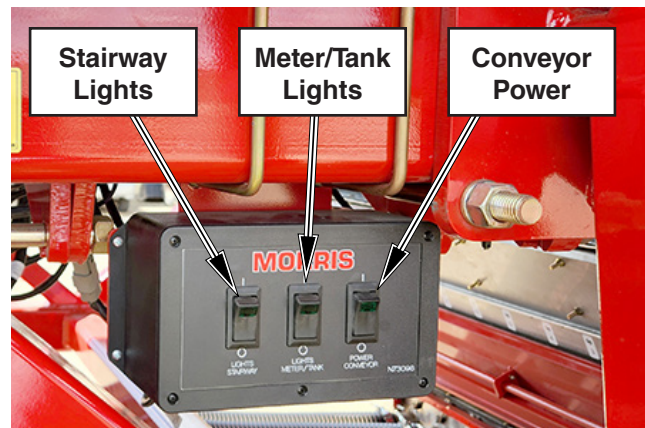
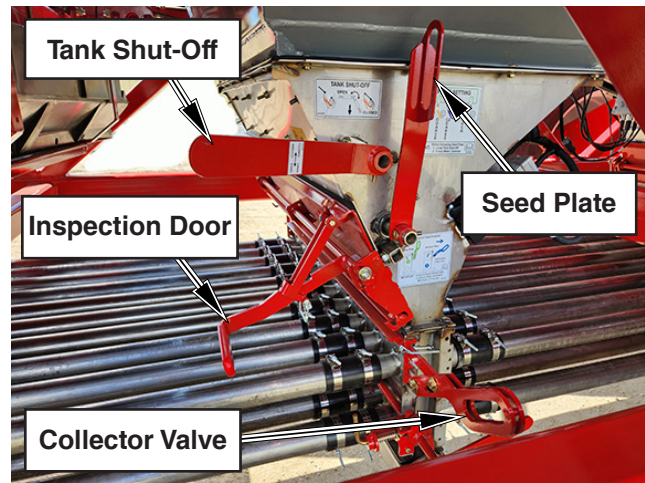

Hydraulic Conveyor

The 16" wide conveyor is designed to make loading and unloading product from the Air Cart tank very simple and easy.

This single belt conveyor with low profile hopper fills tanks rapidly (100 + bu/minute) and features a stainless steel top and bottom to keep this machine looking good for years.

A 10-way remote control is used for movement and speed.



Features - Continued

High Capacity Fans

Push big product rates with the 22" diameter fans and the optional AirGuard blockage prevention system.

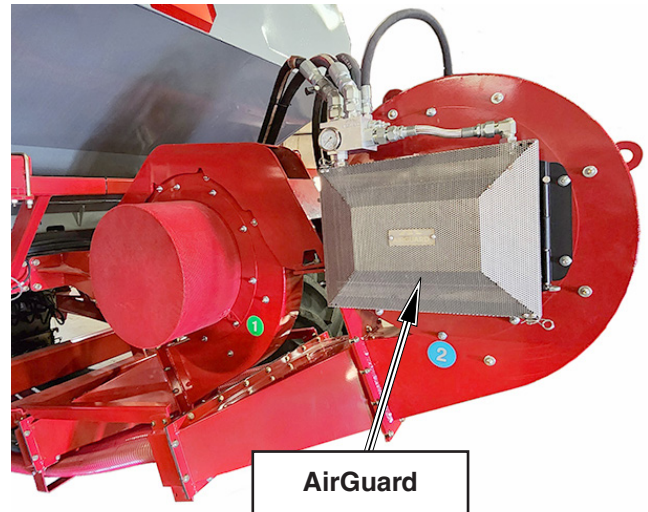

Weigh Scale

The Morris 10 Series Air Cart is equipped with a Digi-Star Weigh Scale system with three load cells on each tank.

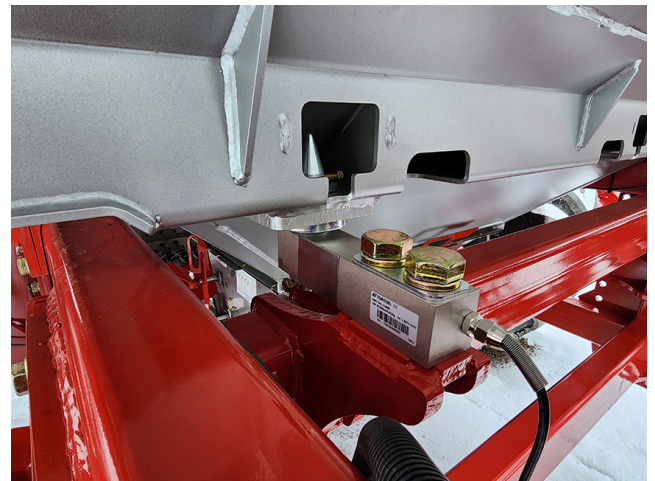

Introduction

Notes

Section 5: Operation

Section Contents

Application	5-3
Tractor.....	5-3
Tractor Drawbar Requirements	5-4
Tractor Hydraulic Connections	5-4
Monitor Installation	5-5
Hitching to Tractor (Seeding Tool or Tow Between Cart)	5-7
Hitching to Seeding Tool (Tow Between Cart)	5-9
Hitching to Seeding Tool (Tow Behind Cart)	5-10
Unhitching from Seeding Tool (Tow Between Cart)	5-11
Unhitching from Tractor (Seeding Tool or Tow Between Cart)	5-12
Unhitching from Seeding Tool (Tow Behind Cart)	5-13
Quad Steer Operation	5-14
Transport	5-15
Speed.....	5-15
Lights	5-15
Brakes	5-16
In-Cab Brake Controller	5-16
Operation	5-17
Installation.....	5-18
Metering System	5-20
Secondary Hose Installation	5-21
Seed Plate Setting	5-23
Seed Plate Adjustment	5-24
Weigh Scale	5-25
Auxiliary Power Unit (APU).....	5-26
Switch Box.....	5-27
Conveyor	5-27
Transmitter Functions.....	5-27
To Register Transmitter to the Receiver	5-28

Operation

Section Contents - Continued

Transport to Tank Fill / Dump Position	5-29
Transport Position	5-31
Conveyor Break-In	5-33
Befor Starting Work.....	5-33
Operating for first 1/2 hour	5-33
After Operating for 5 hours and 10 hours	5-33
Pre-Operation Checklist	5-34
Operation Procedure.....	5-34
Operation Procedure.....	5-35
Stopping Conveyor.....	5-35
Emergency Stopping	5-35
Operating Hints	5-36
Filling Tank.....	5-37
Unloading Tanks	5-39
Rate Calibration.....	5-41
Metering Rate Adjustment.....	5-43
Applying Inoculant	5-43
Airguard Blockage Prevention System	5-44
Start Up Procedure	5-44
Preventative Maintenance.....	5-44
Hydraulic Fan Drive	5-46
Fan Speed Recommendations	5-47
Double Shoot Settings.....	5-50
Collector Valve Settings	5-50
Flapper Valve Run Test	5-50
Operating Guidelines.....	5-51
Seed Rate Settings	5-51
Fertilizer Application.....	5-51
Fan Setting.....	5-51
Product Application	5-51
Checking Seed Flow	5-52
Moisture Alert.....	5-52
Air Leaks	5-52
Tank Low in Product.....	5-52
Monitor	5-53
General Field Operation	5-53

CAUTION



BE ALERT

SAFETY FIRST

REFER TO SECTION 1 AND REVIEW ALL SAFETY RECOMMENDATIONS.

Application

The Morris 10 Series Air Cart applies a wide range of seed and granular fertilizer products. It has the capacity to single shoot and double shoot. See “Double” for more details.

Tractor

Tires

- Proper ballast and tire pressure are required when pulling heavy implements.
- Consult your tractor operator’s manual and follow all recommended procedures.

Drawbar

- Centre and pin in a fixed position for easier hitching and greater stability.

Hydraulics

- Wipe all hydraulic fittings and couplers with a clean cloth to avoid contaminating the system.
- Check that hydraulic reservoir is filled to the proper level.



Warning

Do not permit smoking, sparks or an open flame where combustible fuels are being used. Keep the work area well ventilated.



Warning

Do not search for high pressure hydraulic leaks without hand and face protection. A tiny, almost invisible leak can penetrate skin, that requires immediate medical attention.

Operation

Tractor - Continued



Caution

A safety chain will help control towed machines should it accidentally separate from the drawbar while transporting. A runaway machine could cause severe injury or death. Use a safety chain with a strength rating equal to or greater than the gross weight of the towed machines.

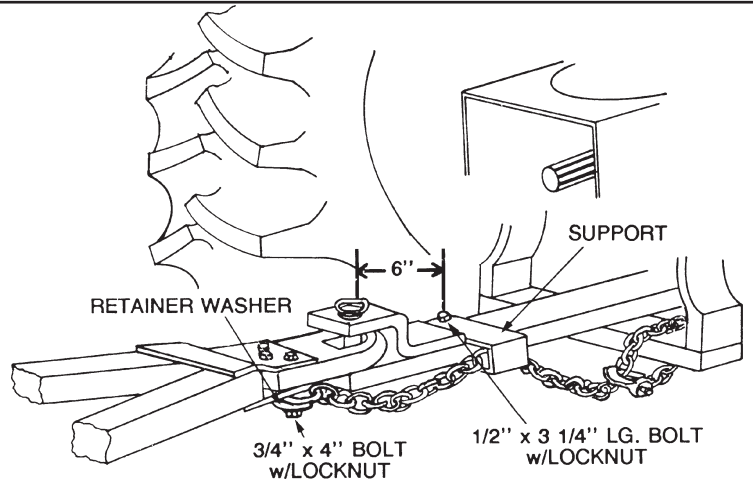

Attach safety chain to the tractor drawbar support or other specified anchor location with the appropriate parts.

Tractor Drawbar Requirements

Tractor drawbar vertical load requirements for loaded Tow Between Air Carts are as follows:

660.....	8,609 lbs (3,905 kg) minimum
820.....	11,622 lbs (5,272 kg) minimum
1050.....	12,994 lbs (5,894 kg) minimum

Tractor Hydraulic Connections

Suggested tractor hydraulic connections are:

Pump 1

- Dual Fans on one Pump

Pump 2

- APU (Auxiliary Power Unit)
- Quantum Lift/Lower/Pressure
- Quantum Wings can go on either pump as it is not used during seeding operations.

Refer to tractor manufactures information for optimal plumbing of hydraulic system.

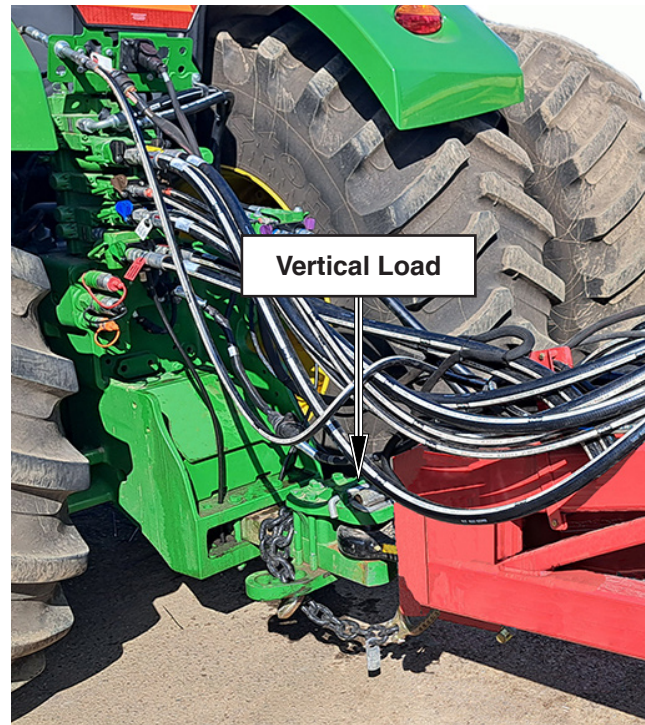

Monitor Installation

XD+ Monitor

1. Install **1019154-01** Power/Comms Harness on tractor.
Connect 1006970-01 Power Cable direct to Tractor's battery.

Important: Battery leads from the Harness must be connected directly to the battery.

Do not connect directly to starter switch.

2. Mount XD+ monitor in tractor cab in an easily visible position.
3. Connect **1019154-01** Power/Comms Harness to the XD+ monitor.
4. Refer to XD+ Monitor manual for more details:

Get the most current version of the Monitor manual at:
<http://www.morris-industries.com/service/product-downloads/>

Important

Some tractors have a 24 volt starting system. The Monitor and ECU will not operate if connected to a 24 volt system. If in doubt, always connect to one battery only.



XD+ Monitor

Important

Ensure harness extensions, when routed over the seeding tool and air cart, are clear of moving parts and protruding objects that may damage wires.



1019154-01 POWER / COMMS HARNESS

Operation

Monitor Installation - Continued

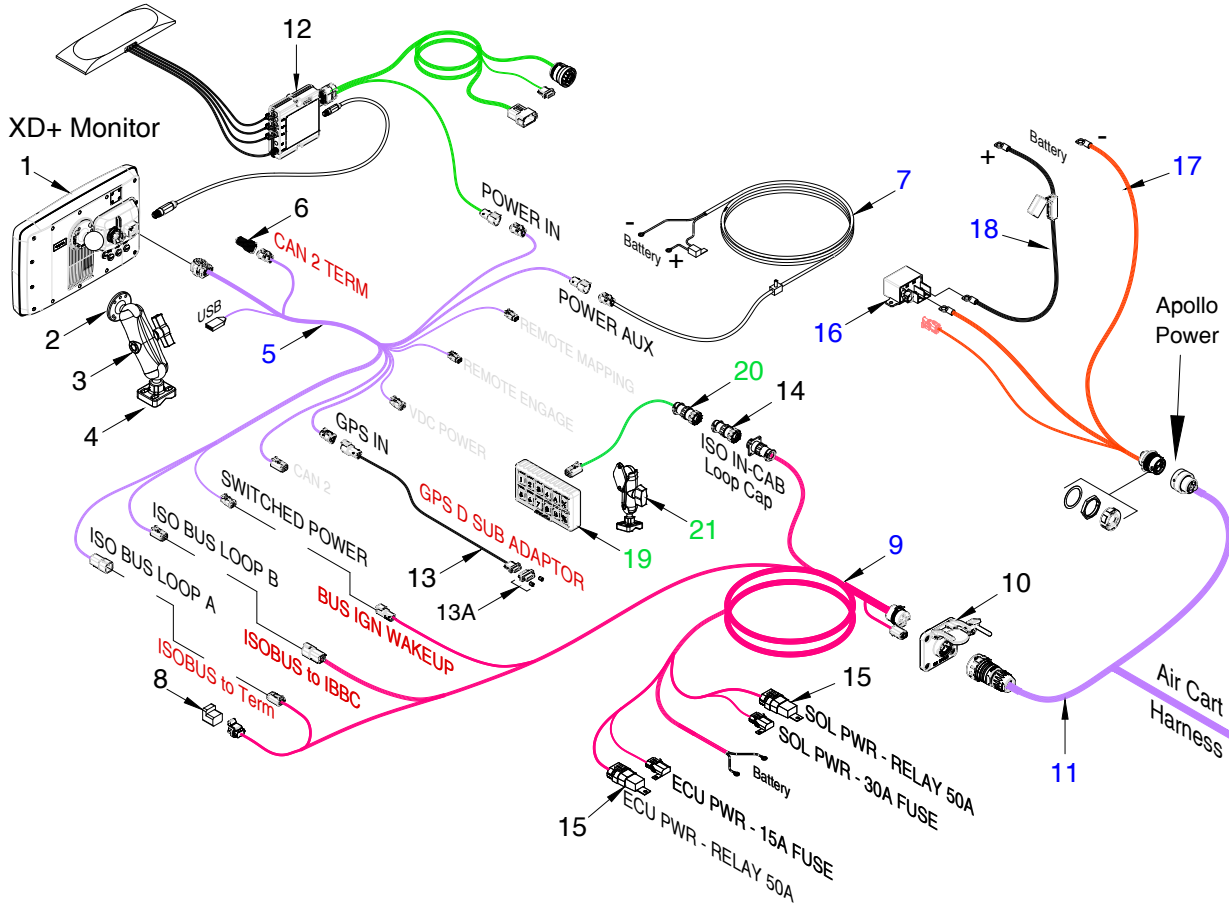

Item	Part No.	Description	Qty
1	N74260	XD+ Monitor Kit E-Drive configured (1070139-01) - Includes Ram Mount Items (2 - 4)....	1
	N55985	Ram Arm Mounting Kit - Contains Items (2, 3 & 4)	1
2	N55984	Ram Mounting Ball - Circular Base.....	1
3	K45686	Ram Mounting Arm - 5"	1
4	K45685	Ram Mount Base - U-Bolt.....	1
5	N64502	Harness - Topcon X35 Power/Comms (1019154-01)	1
6	N56519	Terminator Cap - (AGY1355).....	1
7	N62371	Harness - X30 Power (1006970-01)	1
8	N53054	CAN Term Bias Circuit (AGK159)	1
9	N58965	Harness - GEN 2 LITE (1005455-01) - Includes Items 10,14 and 15	1
10	N56504	Implement Breakaway Connector - IBBC (AGK163)	1
11	N67030	Harness Apollo Lead Implement - 4GA - (1020151-01)	1
12	N74256	TopCon CL-55 Data Modem Kit - (1054855-01)	1
13	N65056	GPS D Sub Adaptor - (1021456-01).....	1
13A	N65130	Kit - Yellow Gender Changer - Includes (1) N65099 and (2) N65098)	1
14	N74244	ISO Loop Cap - [9 Pin Amp circular]	1
15	N72030	Relay - 50A	2
16	N67034	High Current Relay (1004269-01)	1
17	N67035	Harness - Power - 4GA (1004987-01).....	1
18	N67036	Battery Cable - Fused - 4GA (1004955-01) - (100 AMP Fuse N72320).....	1
	N69450	In Cab Keypad Kit - Optional (Includes Items 19, 20 and 21)	1
19	N56500	Keypad (AGA5504)	1
20	N56509	Keypad Cable to 9 Pin (AGA5519).....	1
21	N69448	Ram Mount Kit (1016919-01).....	1

Hitching to Tractor (Seeding Tool or Tow Between Cart)

- Ensure swinging drawbar is locked in the centre position.
- Ensure hitch pin is in good condition.
- Back tractor into position with drawbar a couple of feet in front of cart hitch clevis.
- Ensure hydraulic hose quick couplers are dirt free.
- Inspect all fittings and hoses for leaks and kinks. Repair as necessary
- Connect the hydraulic hoses to the tractor quick couplers.
- Unlock hydraulic hitch jack line lock valve.
- Operate tractor hydraulics to extend hydraulic hitch jack.
- Disengage hydraulic hitch jack lock.
- Operate tractor hydraulics to level clevis with tractor drawbar using hydraulic hitch jack.
- Back tractor into position and attach hitch clevis to drawbar, using an adequate hitch pin.
- Lock hitch pin in place with a hairpin or other proper locking device.
- After tractor to cart connection is made, raise hydraulic hitch jack fully.
- Lock hydraulic hitch jack line lock valve.

Hydraulic Connections:

Pump 1

- Dual Fans on one Pump

Pump 2

- APU (Auxiliary Power Unit)
- Quantum Lift/Lower/Pressure
- Quantum Wings can go on either pump as it is not used during seeding operations.

Refer to tractor manufactures information for optimal plumbing of hydraulic system.



Caution

Dirt in the hydraulic system could damage O-rings, causing leakage, pressure loss and total system failure.

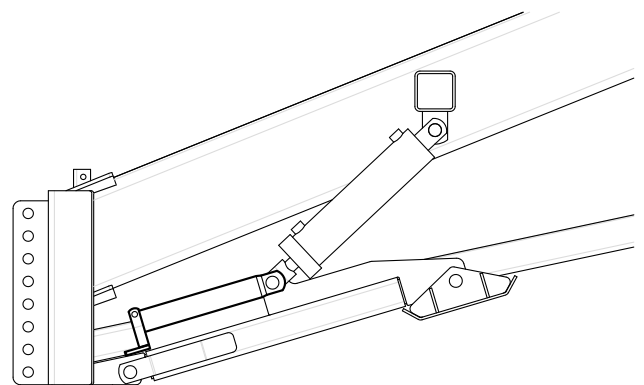
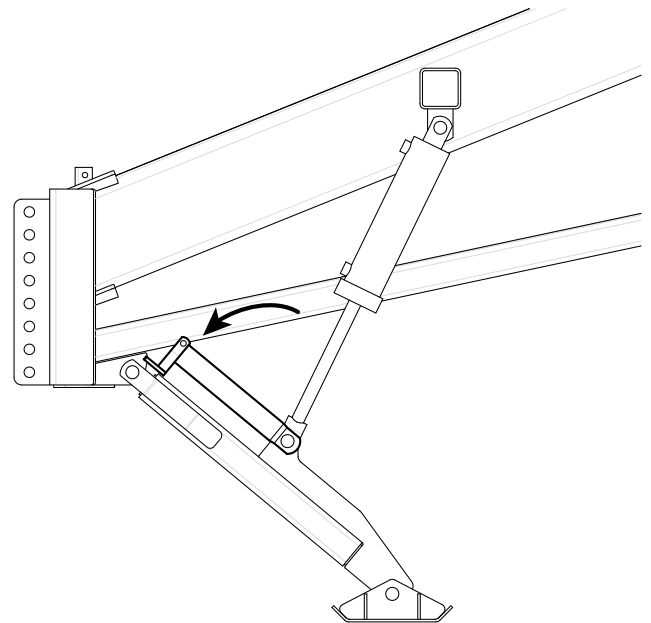

Operation

Hitching to Tractor (Tow Between Cart) - Continued

- Route Safety Chain through chain support and drawbar support per Tractor's Manual.
- Lock safety hook onto chain.

Note: Provide only enough slack in chain to permit turning.

- Connect the monitor quick connectors at both the tractor/air cart and the air cart/seeding tool connections.
- Connect the 7-pin harness.
- Attach breakaway switch cable to tractor.

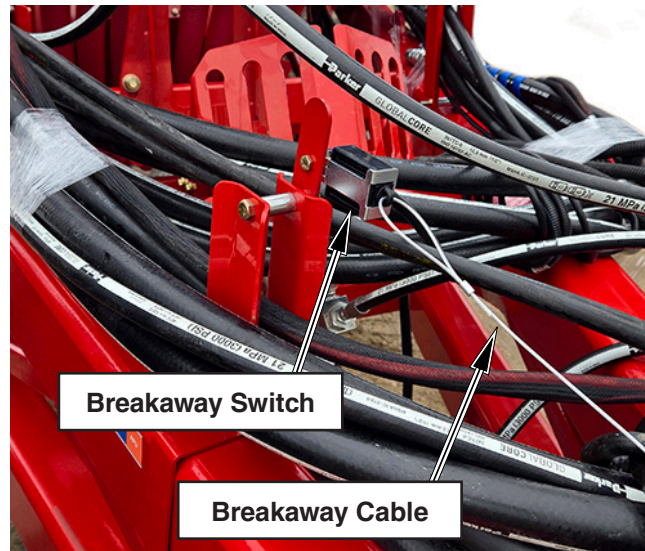

Hitching to Seeding Tool (Tow Between Cart)

- Back air cart into position, aligning seeding tool hitch with air cart.
- Attach hitch to air cart with a 2" x 8 1/2" drop pin and retain with a 5/16" x 2 1/2" quick pin.
- Attach safety chain to air cart.

Note: Provide only enough slack in chain to permit turning.

- Connect hydraulic hose quick couplers.
- Connect the primary hose couplers.

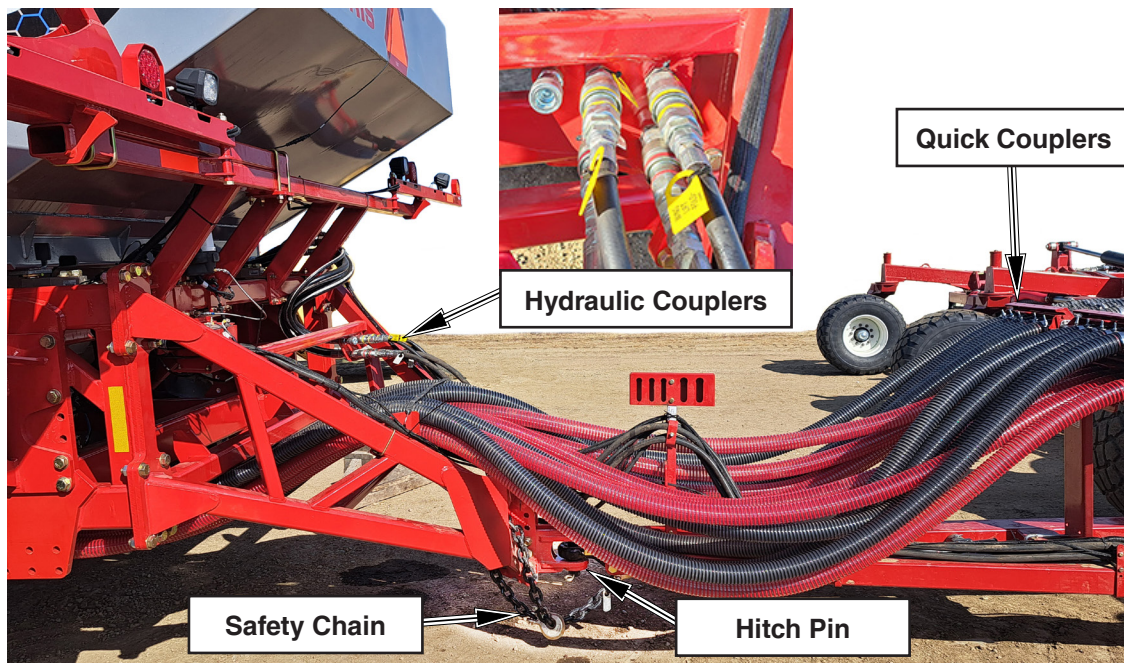

Operation

Hitching to Seeding Tool (Tow Behind Cart)

- Connect seeding unit to tractor.
- Slowly Back seeding tool into position with air cart.
- Attach hitch to air cart with 1 1/2" x 8 13/16" drop pin and retain with a 5/16" x 2 1/2" quick pin.
- Attach cart safety chain to seeding unit.

Note: Provide only enough slack in chain to permit turning.

- Connect the monitor quick connectors at both the tractor/seeding tool and the seeding tool/air cart connections.
- Connect the 7-pin harness.
- Attach breakaway switch cable to seeding tool.
- **Hydraulic fan drive**, connect the fan hydraulic quick couplers at both the tractor/seeding tool and the seeding tool/air cart connections. Ensure couplers are clean and dirt free.



Seeding Tool Coupling

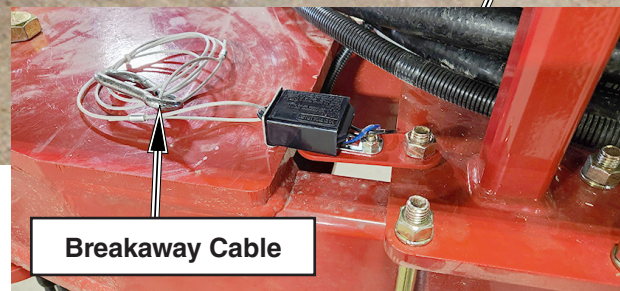
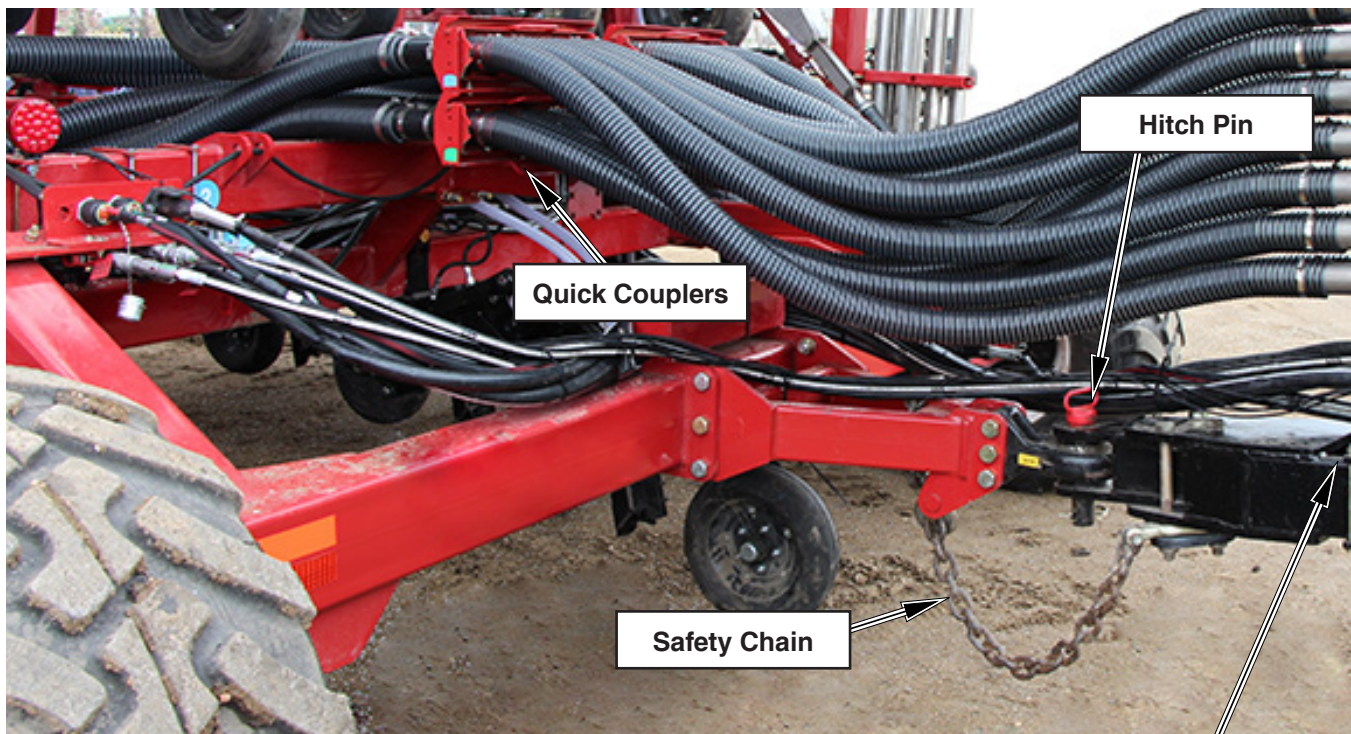

Unhitching from Seeding Tool (Tow Between Cart)

- Lower hitch jack taking the weight off the seeding tool hitch.
- Relieve pressure in the hydraulic hoses by positioning tractor hydraulic lever in “float” position or turn tractor engine off and cycle lever back and forth several times.
- Disconnect the primary hose couplers.
- Disconnect the hydraulic hoses.
- Disconnect the wire harnesses.
- Remove the hitch pin.
- Slowly move air cart away from seeding tool.

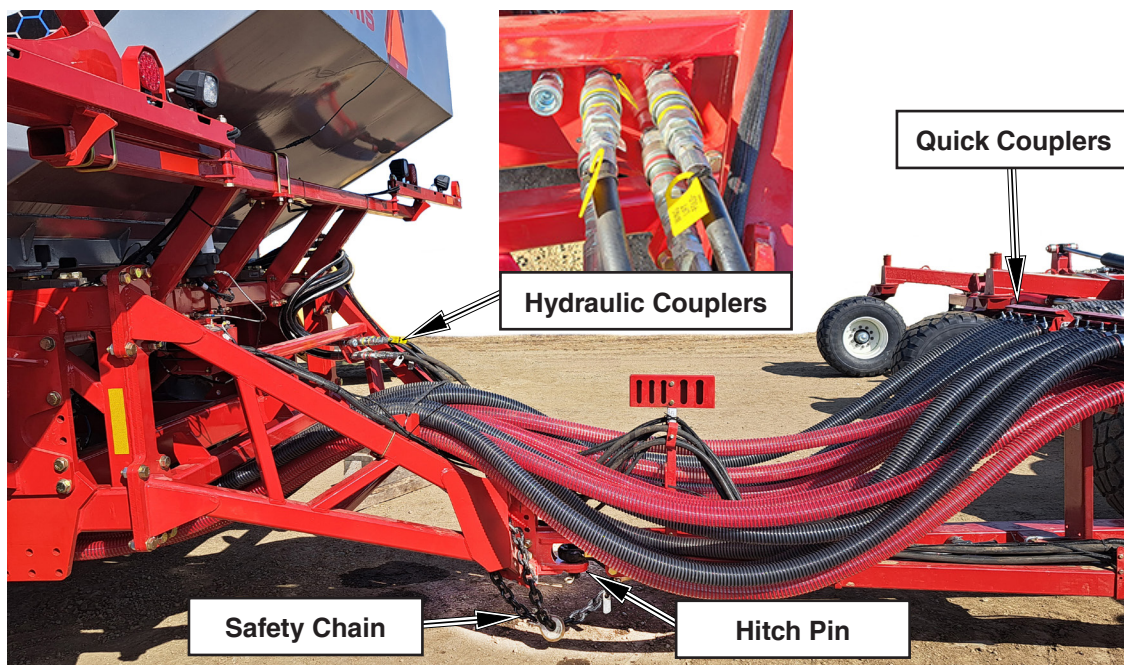

Operation

Unhitching from Tractor (Seeding Tool or Tow Between Cart)

- Unlock hydraulic hitch jack line lock valve.
- Operate tractor hydraulics to lower hydraulic hitch jack taking the weight off the air cart clevis.

Note: For added safety it is recommended to unload any material that may be in the tanks.

- Disconnect the monitor and 7-pin harness.
- Remove the safety chain and drawbar pin.
- Slowly move tractor one foot (30 cm) away from cart.
- Operate tractor hydraulics raising cart hitch to fully extend hydraulic hitch jack.
- Engage hydraulic hitch jack lock.
- Ensure all transport locks are properly secured. Refer to seeding tool manual for more details.
- Relieve pressure in the hydraulic hoses by positioning tractor hydraulic lever in “float” position or turn tractor engine off and cycle lever back and forth several times.
- Lock hydraulic hitch jack line lock valve.
- Disconnect the hydraulic hoses.
- Slowly move tractor away from seeding tool or tow between cart.

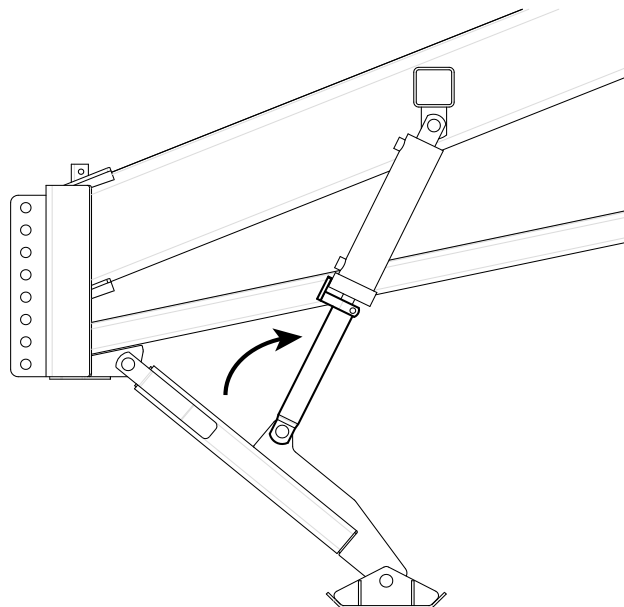

Unhitching from Seeding Tool (Tow Behind Cart)

- Lower hitch jack taking the weight off the hitch.
- Relieve pressure in the hydraulic hoses by positioning tractor hydraulic lever in “float” position or turn tractor engine off and cycle lever back and forth several times.
- Disconnect the primary hose couplers.
- Disconnect the hydraulic hoses.
- Disconnect the monitor cables and 7-pin harness.
- Remove the hitch pin.
- Slowly move seeding tool away from air cart.

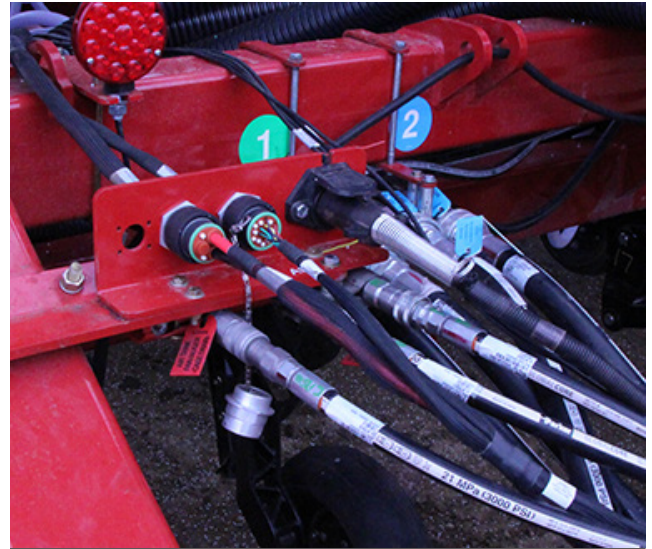

Seeding Tool Coupling

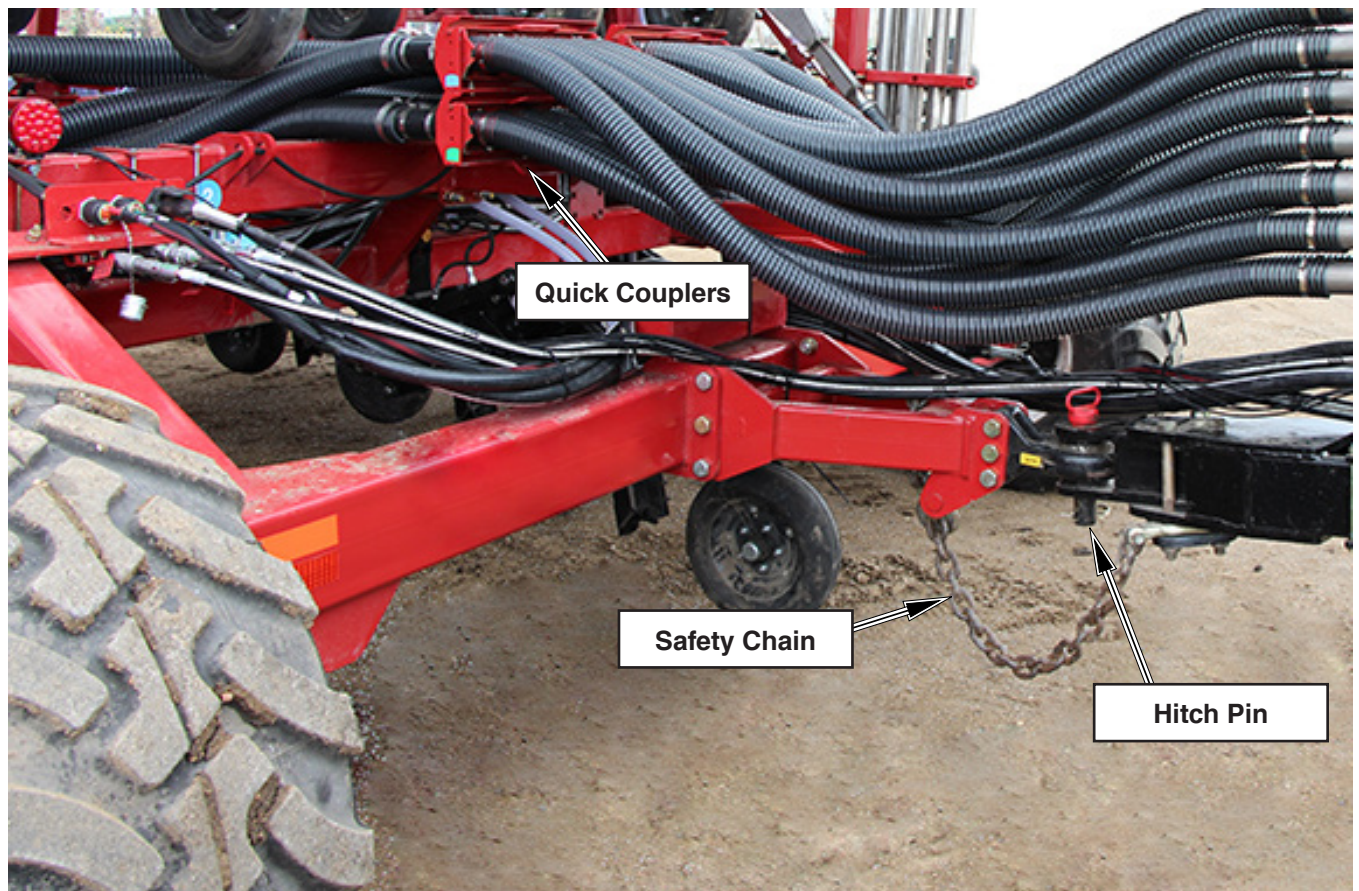

Operation

Quad Steer Operation

- Ensure safety chains are used at hitch pole connection to seeding tool.
- Retorque axle pivot bolts after first 2 hours and periodically afterwards. See “Quad Steer” in Maintenance Section for details.
- Retorque wheel nuts after first fifteen minutes of operation and every 1/2 hour for the next 2 hours. See “Quad Steer” in Maintenance Section for details.
- Avoid sharp turns which cause the steering to reach its limits and drag the front tires of the cart.
- Do not tow cart in excess of 20 mph.
- Do not transport fully loaded cart on roadways.
- Use manufacturer’s rims and tires only.



Important

Extreme care is required when backing up unit.

Hitch damage will occur if axle jackknifes.



Transport

Observe all of the safety precautions under transport heading in Safety, Section 1.

- Refer to Specifications, Section 2, for weight, transport height, and width.
- Transport with tractor only!
- Use Tow Hitch when transporting without seeding tool (Tow Behind Units).
- Always connect safety chain provided to the towing vehicle and the hitch of the air cart.
- Do not transport with the fan running.
- Ensure all transport pins are secured.

MORRIS EQUIPMENT LTD. WILL NOT BE RESPONSIBLE FOR ANY DAMAGES OR OPERATOR INJURY RESULTING FROM NON-USE OR IMPROPER USE OF TRANSPORT LOCKS.

Speed

- Always travel at a safe speed. Do Not Exceed 20 mph (30 km/h) with an empty air cart.
- The combined weight of the implements being towed, including material in tank, **must not exceed 1.5 times** the weight of the towing tractor.
- Use additional caution when towing loads under adverse surface conditions, when turning, and on inclines.



Lights

- Ensure proper reflectors are in place, refer to Safety, Section 1.
- Be familiar with, and adhere to, local laws.

Operation

Brakes

Morris is using Titan's BrakeRite II brake actuation system located on back of frame near rear tires. The Titan BrakeRite II is an electric over Hydraulic brake system. The BrakeRite system is actuated when the brake pedal of the tractor is depressed. The Air Cart brakes can also be applied independently by applying the manual over-ride on the In-Cab Brake Controller.

In-Cab Brake Controller

The In-Cab Brake Control is equipped with a gain control to adjust the braking of the Cart to match operating conditions. The Controller is also equipped with a manual override button to apply the brakes on the Air Cart without applying the brakes on the tractor.

Toggle Switch Functions

- Switch Up (Towards the Operator) brake signal in is turned OFF (RED light flashes). Towing brake signal is used elsewhere. Control will operate in the manual mode only (PUSH button).
- Switch Down (Away from Operator) control responds normally to external brake signal.

Turn Power ON

GREEN LED is ON, indicates control is powered up.

RED LED Light Bar turns on for 3/5 seconds and displays last gain setting. Also, power out to brakes is on for this period.

Set Gain

Press the + symbol to increase braking if inadequate Cart braking is being experienced.

Press the - symbol to decrease braking if excessive Cart braking is being experienced.

Note: These Buttons must be pressed repeatedly to change setting. Holding the buttons pressed only moves 1 step. Gain settings can be changed only when there is no external brake signal present.

Manual Operation

Press "PUSH" button with variable force to apply brakes manually. This button is pressure sensitive.

Higher Pressure on button = Higher brake pressure

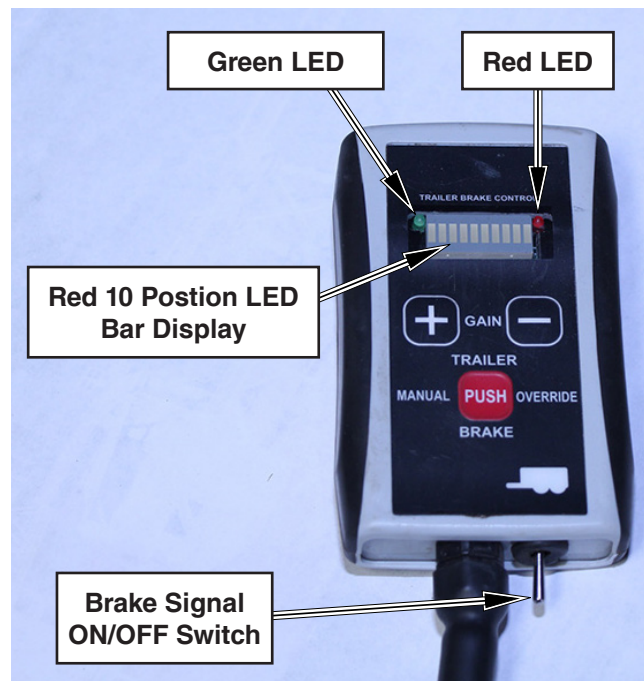
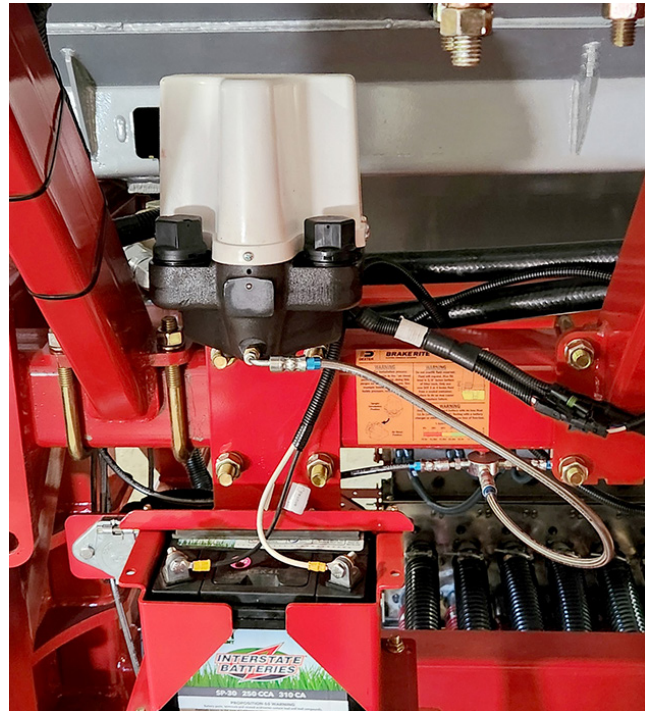

GREEN LED is ON when 12v power is in control.

RED LED flashes when brake switch is in the OFF position.

RED 10 positions LED Bar displays gain and level of braking.

Brakes - Continued

Operation

Before using the Air Cart always check:

1) Proper Brake Fluid Level:

Must be between 3/8 & 1/2 inch of filler opening.

2) Prior to Moving the Coupled Unit:

a. Verify the brake system is working properly.

To assure proper connections have been made, check In-Cab Controller green LED should light when switch is in ON position. Before moving the Cart depress the Tractor brake pedal, the BrakeRite unit should start (you can hear the unit running). Release the Tractor brake pedal and activate the BrakeRite unit by operating the “manual override” on the In-Cab Controller, again you will hear the unit turn on. With the manual override you are able to tell by the change in tone that the system is building pressure relative to the amount of “activation” initiated on the override switch. **Do Not attempt to move the unit until the brake system performs in the tests described above.**

3) When Operating/Transporting the Air Cart:

- a. Do not rely on the Air Cart brakes for deceleration of the entire combined unit braking. The Air Cart Brakes are designed for braking of the Air Cart only and not the entire combined unit.
- b. Always operate the combined unit within the specified parameters outlined in the Tractor Owner Manuals and OBEY ALL LAWS.

PROPER ELECTRICAL WIRING is CRITICAL for the performance of any of these systems. Improper wiring can result in damage to the actuation system or system failure after initial use. A “pure ground” and direct power (+12 VDC) with fuse or circuit breaker (30 amp) are necessary to ensure good performance.

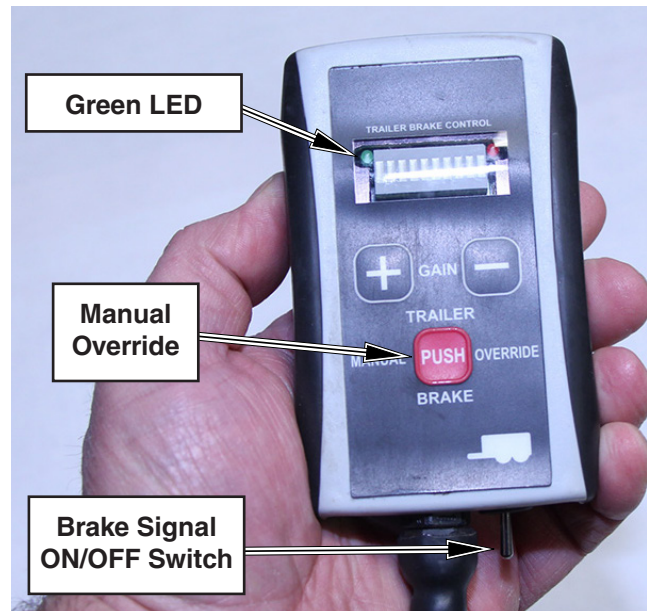

Important:

Use only DOT III brake fluid.

Maintain fluid level within 3/8 to 1/2 inch below the filler opening.

Use caution when removing the filler cap to prevent contaminants entering into the fluid reservoir.

Operation

Brakes - Continued

Operation - Continued

Getting the feel of the system and setting the In-Cab controller:

After the system responds to the tests previously described proceed with moving the unit to establish a feel for the brake system and set the desired brake response by setting the gain on the In-Cab Brake Controller.

Do Not attempt to operate this unit in traffic until totally familiarized with the “feel” and performance of the system. Every operator must be familiarized with the feel of the unit, the performance of the brake system, and the proper operation and setting selections of the In-Cab Brake Controller.

Operation:

Air Cart brakes are meant to assist the Tractor in the stopping of the combined units, they are not intended to stop the entire combined unit.

Thoroughly know the In-Cab Controller's performance and “feel” before any extensive travel is considered.

Manual override should be fully understood for safe operation. When operating on wet/slippery surfaces or going down a steep incline it is desirable to brake only with the Air Cart brakes to maintain alignment of the implements and help prevent a jack-knife condition. By maintaining adequate braking on the Cart, sway or the tendency of the Cart to “push” the Tractor is greatly reduced.

Installation

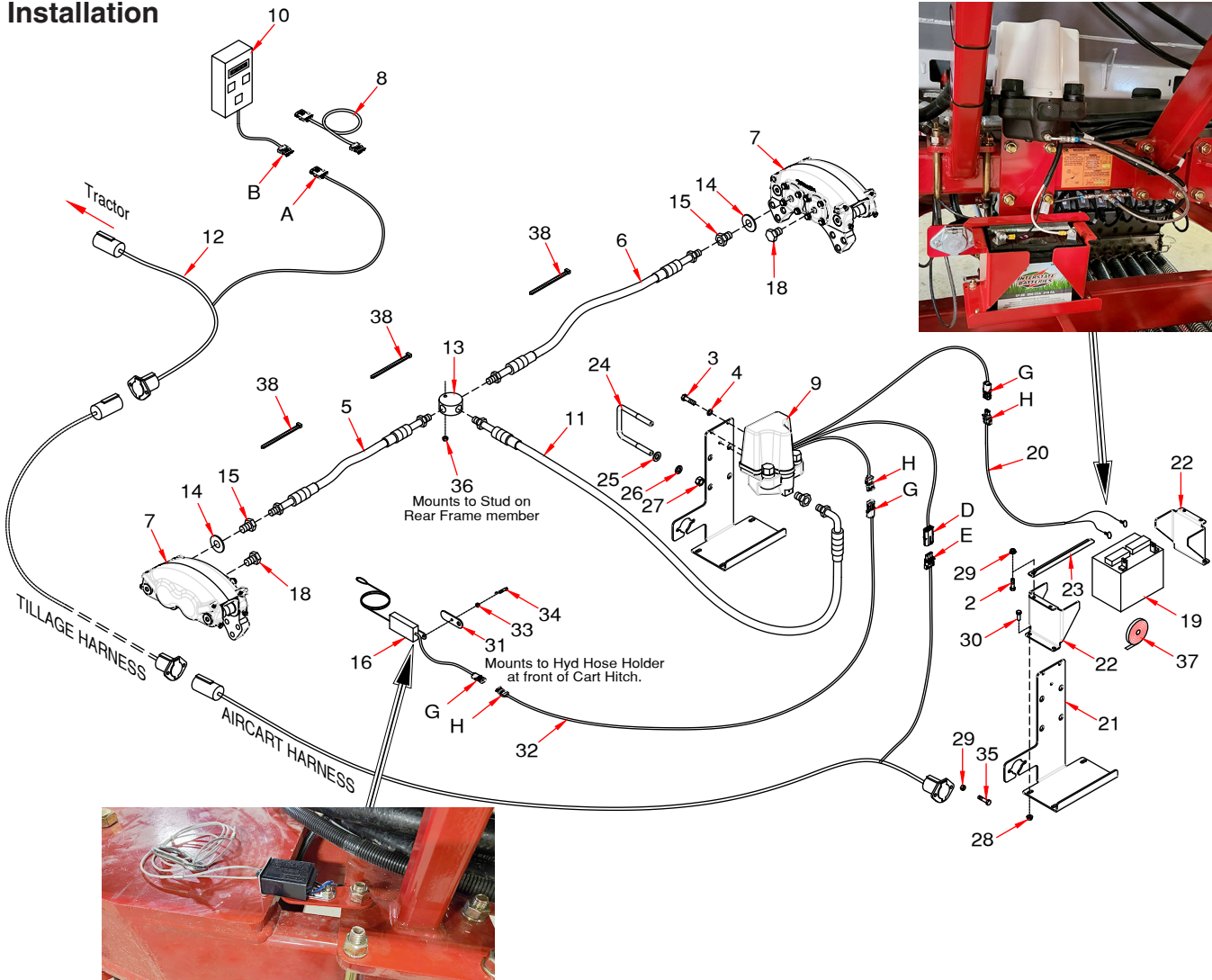

Brakes - Continued

Installation - Continued

Item	Part No.	Description	Qty
1	N73165	Air Cart Lighting Harness - 620 Lg.....	1
2	F-1767	Bolt - 5/16 x 3/4 Lg.....	2
3	W-471	Bolt - 5/16 x 1 Lg.....	3
4	W-522	Lockwasher - 5/16.....	3
5	N53387	Brake Hose - 1/4 x 150 Lg.....	1
6	N53388	Brake Hose - 1/4 x 180 Lg.....	1
7	N53389	Brake Caliper Assembly.....	2
8	N56076	Extension Harness - Cab Controller - 10 ft Lg.....	1
9	N71445	BrakeRite EHB - Electric/Hydraulic Actuator/Control Module - K68-001-02.....	1
10	N53397	BrakeRite SD AG Controller - 4858800.....	1
11	N53398	Brake Hose - 1/4 x 24.....	1
12	N53650	Wiring Harness - Cab Controller - 96 Lg Brake Lead.....	1
13	N53652	Brass Tee Fitting.....	1
14	N53653	Brass Brake Washer - 1/2 ID x 7/8 OD.....	2
15	N53654	Brass Adaptor - Brake Fitting.....	2
16	N53393	BrakeRite SD Breakaway switch - 4834500.....	1
17	N53395	Brakerite SD Battery Cable - 4834400 - Optional battery hook up (Not Shown).....	1
18	N55840	Plug - 5/16 MORB.....	2
19	N53577	Battery - 250 CCA - Interstate #SP-30.....	1
20	N53571	Battery Cable -.....	1
21	N70431	Holder Plate - Battery.....	1
22	N53578	Bracket - Battery.....	2
23	N53579	Clamp Strap - Battery.....	1
24	C-219	U-Bolt- 5/8 Dia.x 4 x 5 9/16 UL.....	2
25	W-629	Washer - 5/8 x 1 5/16 x 13 Ga.....	4
26	W-526	Lockwasher - 5/8.....	4
27	W-517	Nut - 5/8.....	4
28	D-5279	Locknut - 3/8 Flange.....	4
29	D-5278	Locknut - 5/16 Flange.....	4
30	W-475	Bolt - 3/8 x 1 Lg.....	4
31	N73163	Bracket Mount - Brakes Breakaway.....	1
32	N73164	Harness - Brakes Breakaway - Cart.....	1
33	N22778	Locknut - 1/4.....	1
34	W-469	Bolt - 1/4 x 3/4 Lg.....	1
35	N29048	Carriage Head Bolt - 5/16 x 1 Lg.....	2
36	C32925	Locknut - 5/16 Center.....	1
37	N15716	Seal Strip - 1/4 x 1/Foot.....	3 FT
38	D-4951	Nylon Tie Strap - 7 3/8 Lg.....	12
	N52683	Brake Hose Kit - (Contains Items 5, 6, 11, 13, 14 &15)	
	N53391	Brakerite EHB Kit - (Contains Items 9, 16 & 17)	
	N73162	Breakaway Kit - (Contains Items 31,32, 33 & 34)	
	N70407	Brakerite Controller Assy - (Whole Goods Only) - (Includes all Items above except 19)	

Operation

Metering System

The 10 Series Air Cart uses an electric drive for each meter wheel.

Electric drive air carts use only one meter wheel size in each meter body. Calibration factors are determined based on physical calibration. The seeder software then knows the weight/rev (lbs/rev) of the meter body based on this number. The profile of the seeder is set up so that each section is feeding a known width of the air drill that it is paired with it. The system will adjust the meter wheel RPM of each section to apply the target rate based on the GPS speed and drill width the section is matched to.

The 10 Series Air Cart can meter all types of seeds and fertilizers by simply adjusting the seed plate. See “Seed Plate Settings” for more details.

Note: Before putting product into the tanks check the following:

1. The Seed Plates are correctly set for the product being applied.
2. The clean-out doors are fully closed and sealed.
3. The plastic bag covering the fan is removed.

Important

Ensure distribution system is balanced. It is very important that head outlets only vary by one. (i.e. use only 7 and 8 together, 8 and 9 together, 9 and 10 together)

6 Outlet Head

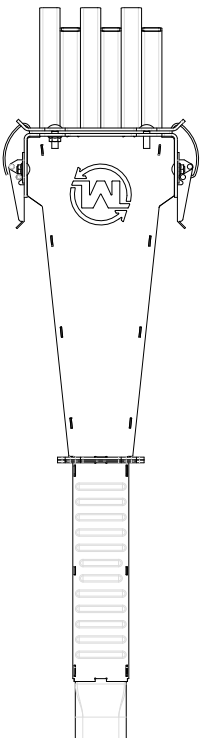

7 Outlet Head

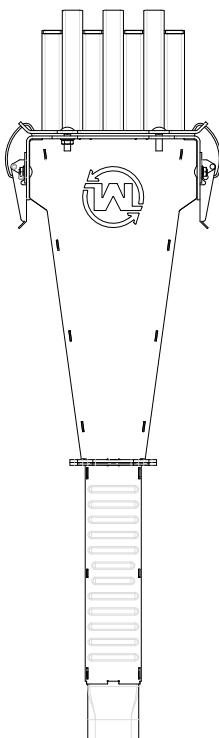

8 Outlet Head

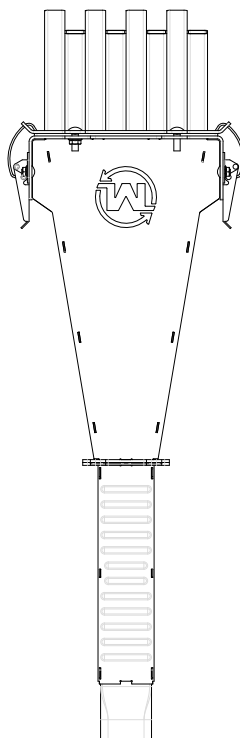

9 Outlet Head

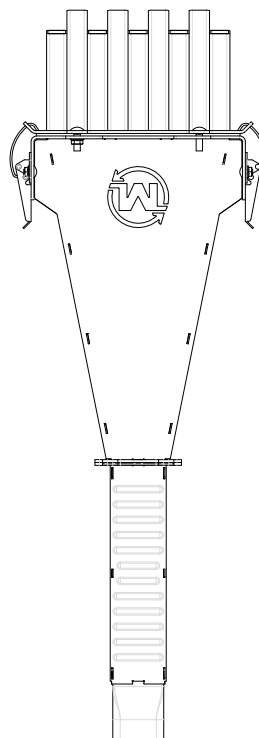

10 Outlet Head

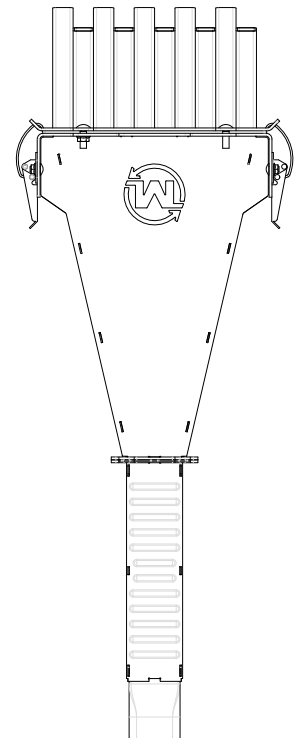

Metering System - Continued

Secondary Hose Installation

The lengths of the secondary hoses are **very important**.

For accurate distribution the secondary hoses have to be arranged by length symmetrically around the centre line.

The **longest** hoses **have to be** in the **centre** of the divider head. These hoses would normally feed the openers furthest away from the head.

- Ensure that the secondary hoses do not run higher than 3" (76 mm) above the height of the flat fan divider head.
- Allow an extra 3" (76 mm) of hose before cutting secondary hose for fitting in the seed boot.
- Always ensure that the secondary hoses are sufficiently long to accommodate tripping of trips.
- **Avoid sharp bends** in any of the hoses.
- Check for pinch points and clearances when folding in and out of transport.

Important

Distribution uniformity will be adversely affected if hoses are incorrectly installed.

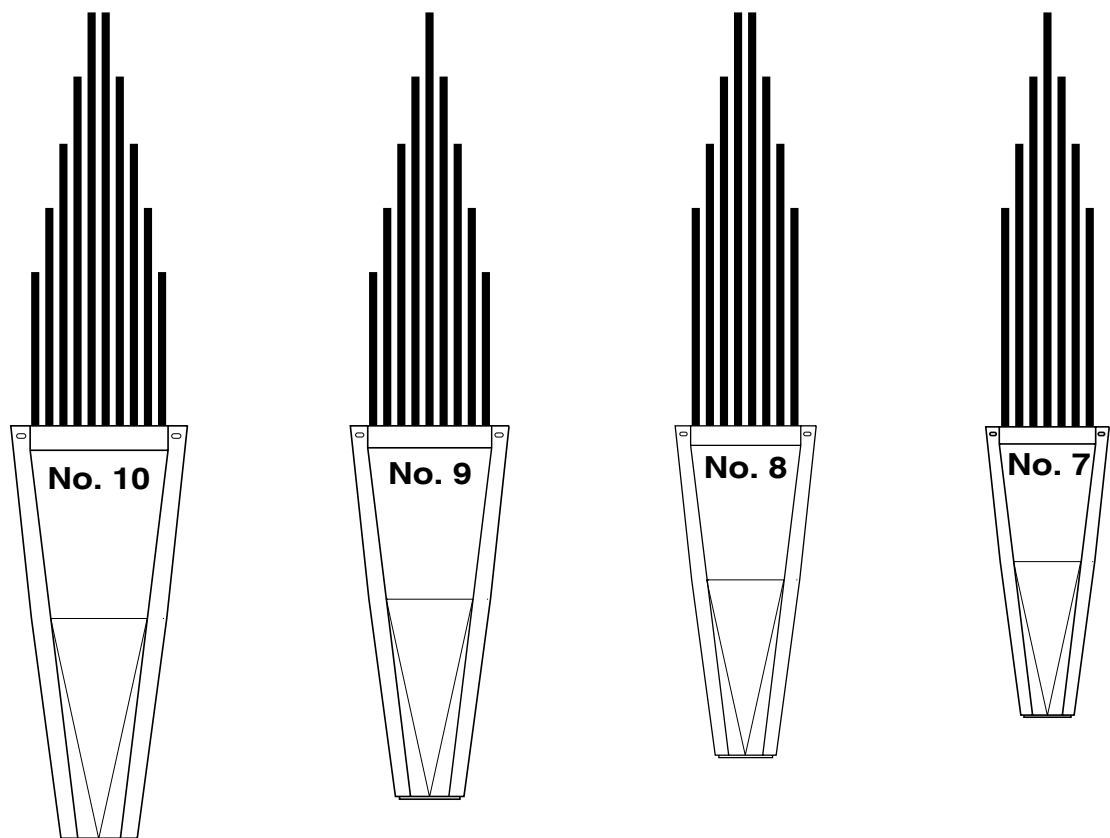

Operation

Metering System - Continued

Identifying Lever Functions

Seed Plate lever changes the clearance between the meter wheel and seed plate.

Tank Shut-Off lever is used to close off any product from entering the metering body.

Collector Valve lever is used to change which air stream the product will meter into. Note lever positions for Tow Between are opposite from Tow Behind.

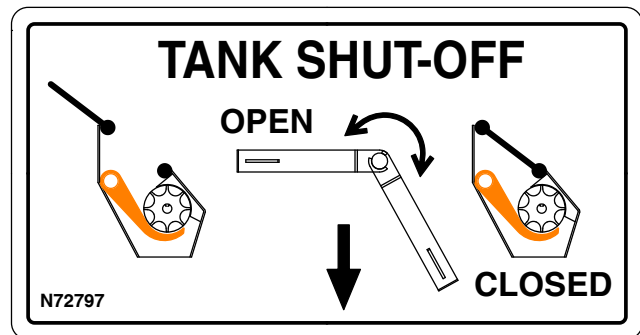
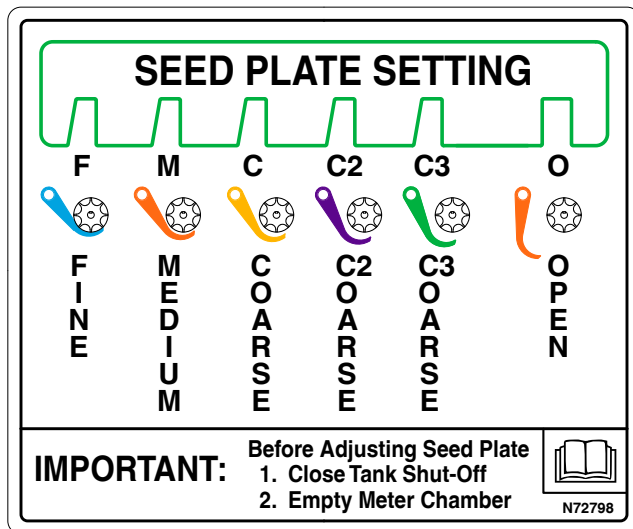
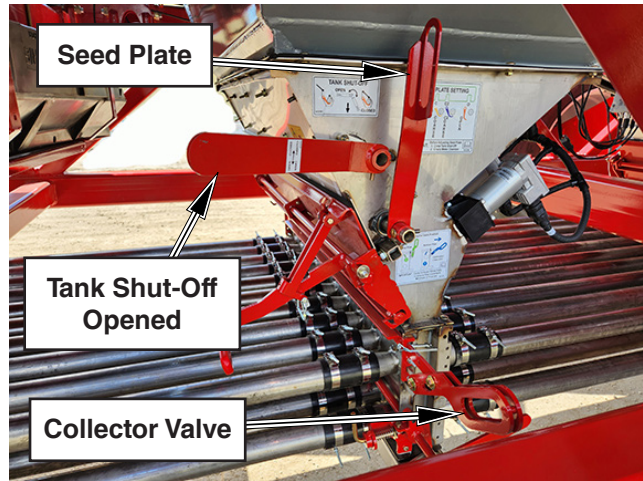

Note: Collector Valve Lever positions for Tow Between are opposite from Tow Behind.

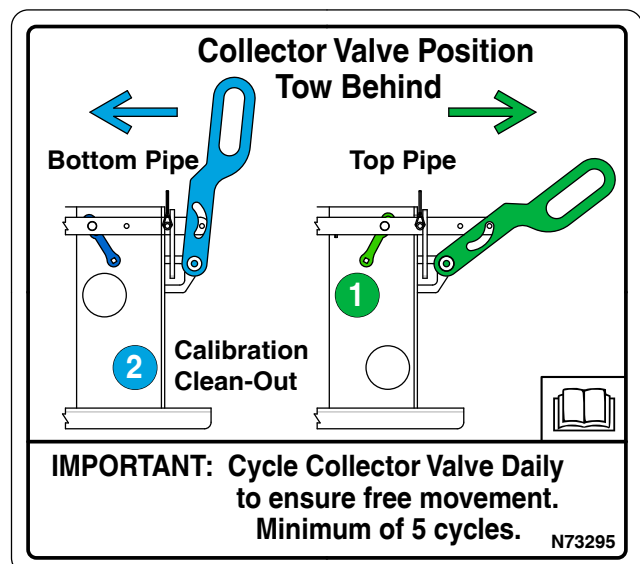
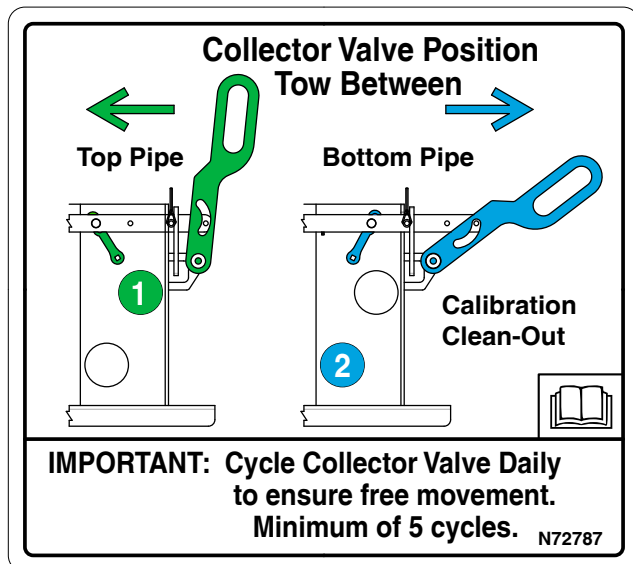

Metering System - Continued

Seed Plate Setting

Each meter wheel has an adjustable seed plate.

The seed plates are adjusted by a single lever adjustment on the metering body assembly.

Note: Seed Plate Chart is a suggested usage. Product variations could require a different setting to be used for proper metering.

i.e. Clean 11-51-0 Fertilizer may require a Medium seed plate setting to reduce product flow.

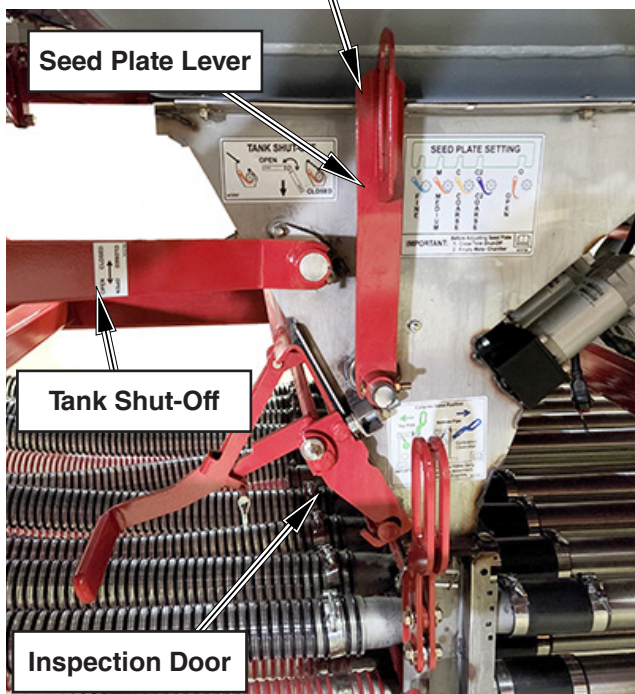
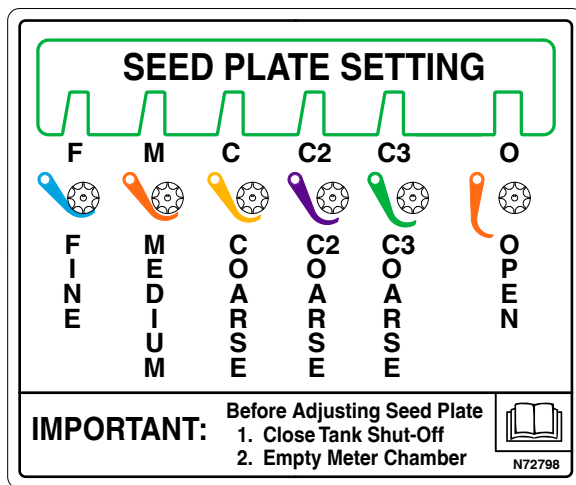

Important

Do not attempt to close Seed Plate with product in the Metering Body, damage can occur from product being squeezed between the meter wheels and seed plates.

Seed Plate Setting

Product	Seed Plate Position
Canola Canary Seed Clover/Alfalfa Flax Mustard Nitragin Edge Fortress Rival	Fine
Barley Lentils Milo Oats Rice Wheat Safflower Nodulator Tag Team Fine Fertilizer (with no Sulphur or Potash) 28-0-0 Fertilizer 46-0-0 Fertilizer 34-17-0 Fertilizer 20.5-0-0-24 Fertilizer	Medium
Beans Peas Soybeans Sunflowers 0-0-60 Fertilizer 0-45-0 Fertilizer 10-46-0-0 Fertilizer 11-51-0 Fertilizer Fertilizer containing Sulphur and/or Potash	Coarse

Operation

Metering System - Continued

Seed Plate Setting - Continued

- Ensure Tank Shut-Offs are closed if there is product in the tanks.

Note: Tank Shut-Offs are only for use when inspecting/servicing meter body with product in tank.

- Open inspection door and rotate seed plate fully open.
- Inspect Seed Plates and meter wheels to ensure they are free of debris.
- Set seed plate lever to appropriate notch per Seed Plate Usage chart.
- Close inspection door ensuring that the seals are free from debris and leaks.
- Ensure Tank Shut-Offs are opened.

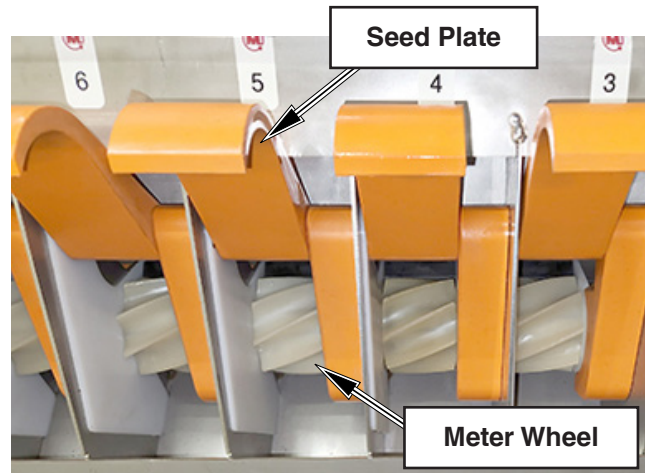
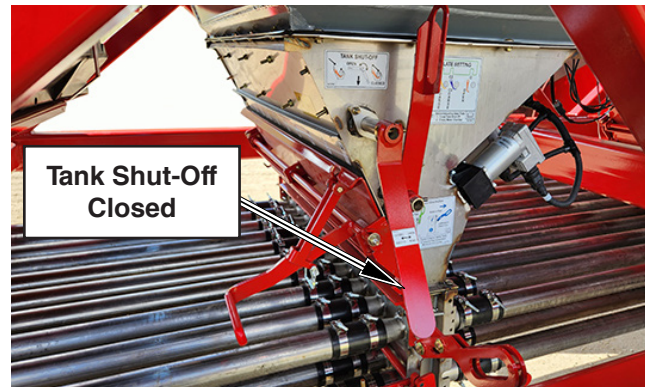

Ensure Metering is Free of Debris

Important

Seed Plate Adjustment

Ensure that when the adjustment handle is in the Fine position notch that the seed plates are tight up against the metering wheels spacers.

If this does not occur adjust the adjustment plate by loosening the bolts that attach the plate to the metering body and slide the plate accordingly.

This adjustment must be done without product in the tank or with the slide gates closed and the metering body cleaned out.

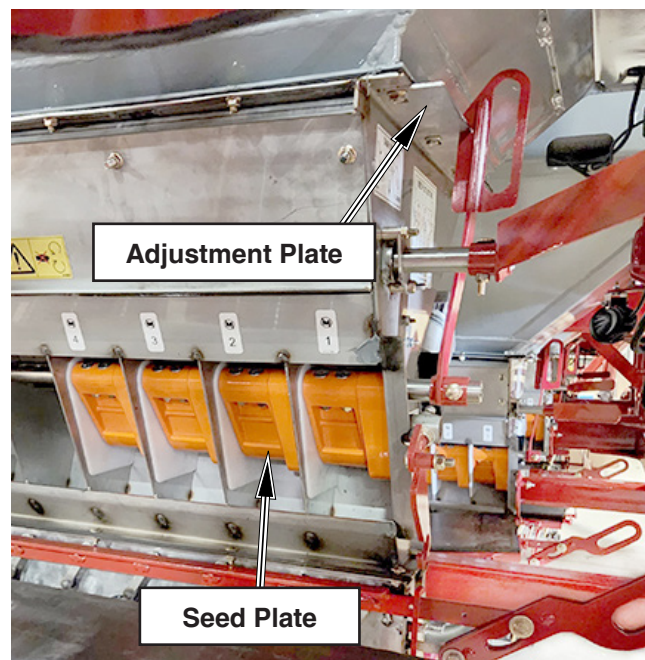

Weigh Scale

The Morris 10 Series Air Cart is equipped with a Digi-Star Weigh Scale to track product usage.

Refer to the XD+ Monitor manual for setting and operating the scale.

The Digi-Star system requires the following numbers listed below to get the best feedback from the system - for the load cell setups utilized.

- For each tank, assign the appropriate Setup Number and Calibration Number.
 - These numbers are based on the size of load cell used on each tank as listed below.



Cart	Load Cell Location			
	Tank 1 Scale A	Tank 2 Scale B	Tank 3 Scale C	Tank 4 Scale D
660	5K - 3 cell	10K - 3 cell	10K - 3 cell	20K - 3 cell
820	5K - 3 cell	20K - 3 cell	10K - 3 cell	20K - 4 cell
1050	5K - 3 cell	20K - 3 cell	10K - 3 cell	20K - 4 cell
1440	5K - 3 cell	20K - 4 cell	10K - 3 cell	20K - 4 cell

Load Cell	Imperial		Metric	
	Setup #	Cal #	Setup #	Cal #
5k - 3 cell	125008	2000	525004	907
10K - 3 cell	125015	4000	525007	1814
20K - 3 cell	126030	8000	525014	3629
20K - 4 cell	125040	10667	525019	4838

Scale	Affects Scale	Setup Number	Calibration Number
A	None	125008	2000
B	None	126030	8000
C	None	125015	4000
D	None	125040	10667

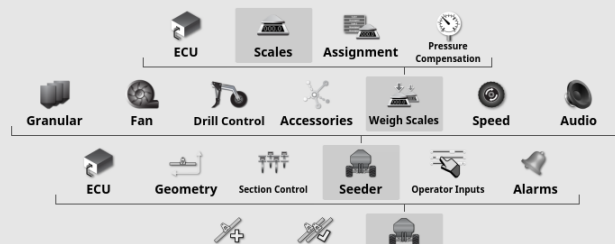

Note: The "Affects Scale" column is required to be set to None.

Operation

Auxiliary Power Unit (APU)

The second platform step is divided into 3 compartments. The compartments are for the alternator, storage and ECU electrical.

Alternator Module

- Location of the hydraulic alternator drive.
- The hydraulic motor speed is regulated through a flow control valve.

ECU Module

- Location of the CM-40
- Location for fuses and 24V relay.
- Master switch turns ON/OFF power to Cart.

Batteries

The batteries are located under the first step.

Important: Alternator unit must be run at all times during operation to maintain battery charge. This includes calibration, conveyor and lights operation.

When Air Cart is not in use for an extended period on time turn OFF the Power.

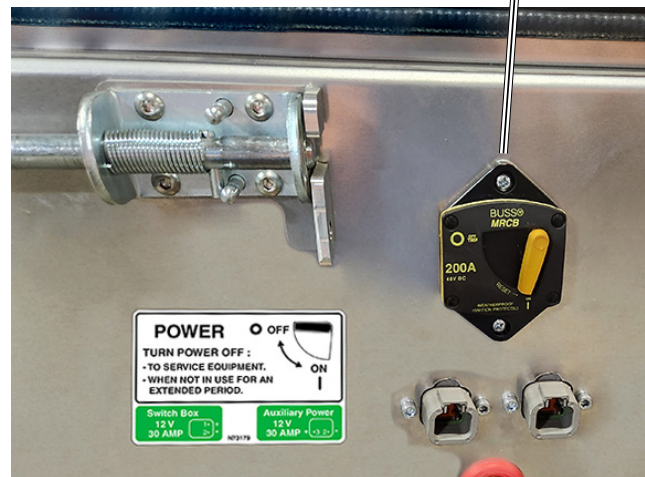
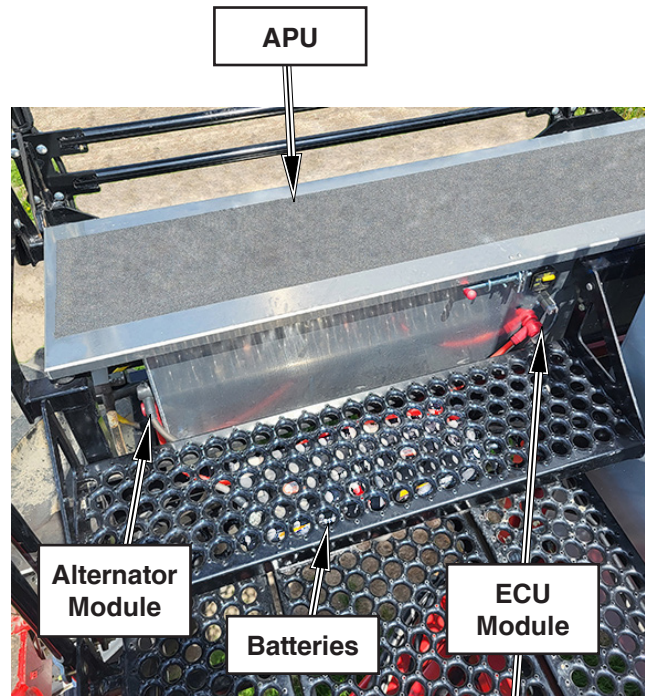

Important:

**DO NOT Run Alternator with
Power turned OFF.**

Damage to the Alternator may occur.

Switch Box

Identifying Switch Box Functions

Lights Stairway switch turns on the lights that illuminate the stairway and upper walkway.

Lights Meter/Tank switch turns on the undercarriage lights for the metering bodies. It also turns on the lights inside the tanks.

Power Conveyor switch turns on the receiver and lights on the conveyor. It also powers the conveyor valve block relays.

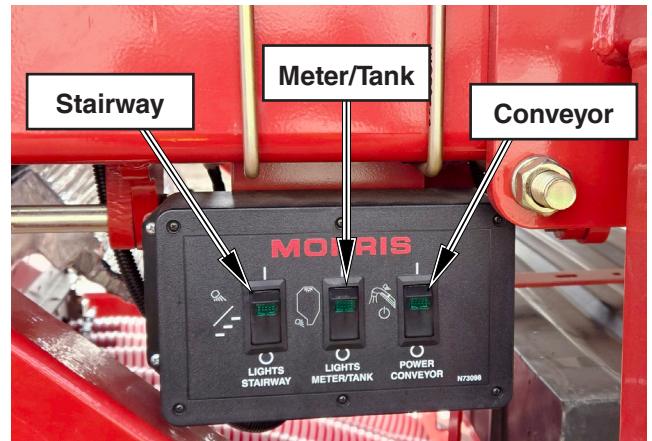

Conveyor

Transmitter Functions

- Be familiar with the functions of the Transmitter.

Reference	Function
1	OFF
2	ON
3	Rotate inner arm assembly out
4	Rotate inner arm assembly in
5	Rotate outer arm assembly out
6	Rotate outer arm assembly in
7	Tilt auger spout up
8	Tilt auger spout down
9	Lower conveyor on parallel links Lock Transport Locks
10	Raise conveyor on parallel links Unlock Transport Locks
11	Belt - Slow Speed ON/OFF
12	Belt - Fast Speed ON/OFF



Operation

Conveyor - Continued

To Register Transmitter to the Receiver

- Switch OFF the power to the Receiver and briefly PRESS the STOP button on the Transmitter.
- Switch ON the power to the Receiver. This opens a 20 second registration window in the Receiver processor.
- If you are looking at the Receiver PCB the Fault LED Flashes. Immediately PRESS and HOLD both the Transmitter RESET Button and F1 Button (indicated). Continue to hold BOTH BUTTONS for a MINIMUM of 5 seconds during this 20 second window. When the Transmitter is Registered the Fault LED will be illuminated for 3 seconds. Within this 3 second period, FIRST release F1 and then the RESET button.

STOP Button switches off the Receiver and the keypad function buttons.

RESET Button activates the Receiver and the keypad function buttons.

L.E.D.

Blinks When Transmitter is active.

ON when a Transmitter Button is pressed.

Pulses while transmitting when Battery is low.

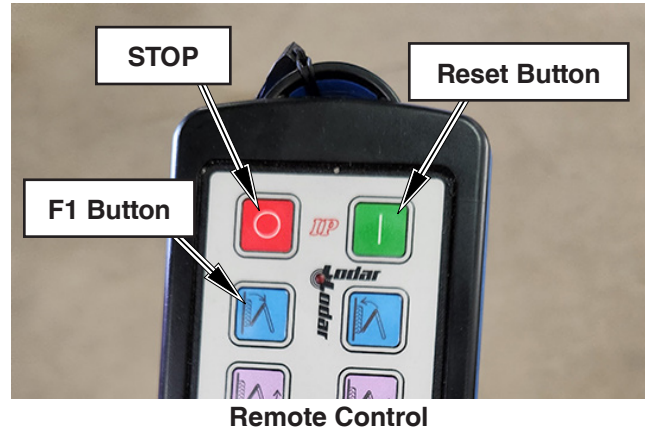

Conveyor - Continued

Transport to Tank Fill / Dump Position

- One person must be in a position to monitor the operation of the conveyor at ALL times.
- Engage tractor hydraulics in correct direction for Conveyor operation on Fan 1 circuit.
- Switch conveyor power ON at the switch box.
- Turn ON the transmitter.

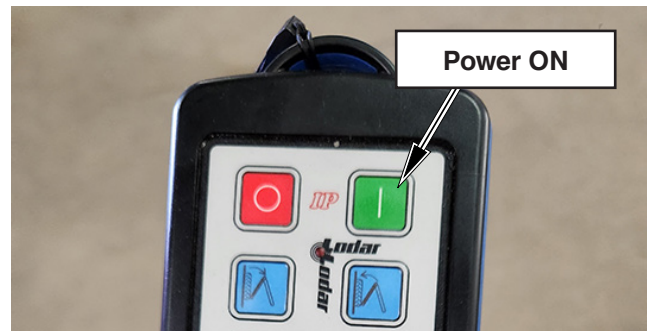

- Switch conveyor valve to the "Lock/Unlock" position.

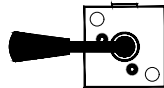

- Unlock cradle pads on the conveyor by operating Raise button on the Transmitter.

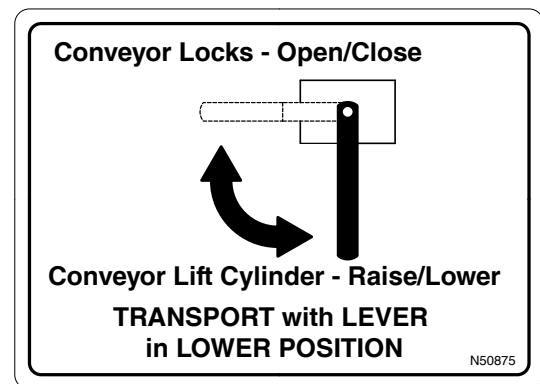

- Check to ensure both locks are fully released.

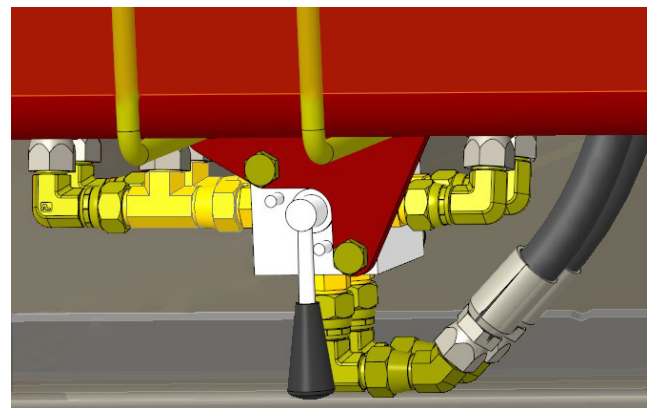

- Switch conveyor valve to the "Lift Cylinder" position.

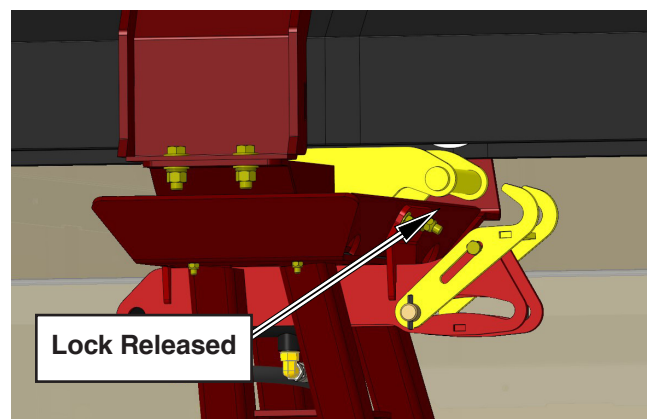
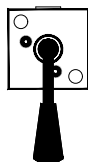

Operation

Conveyor - Continued

Transport to Fill / Dump - Continued

- Hold Tether Strap securely to control the position of the conveyor.



- First raise the parallel links lifting the conveyor off the transport rests while holding the tether strap to control conveyor position.
- Swing out the inner and outer arm slightly so conveyor is clear of transport rests.



- Retract the tilt cylinder a small amount to raise conveyor spout up slightly to clear tanks.



- Swing out the conveyor using transmitter to extend/retract cylinders as required to position conveyor in desired position. Use chart below as a guide.



CONVEYOR ARM POSITIONS					
	INNER	OUTER		INNER	OUTER
TRANSPORT	#	#	RETRACT*	#	B
FILL T1	O	W	DUMP T1	K	R
FILL T2	N	W	DUMP T2	M	V
FILL T3	F	O	DUMP T3 (BHND)	F	O
			DUMP T3 (BTWN)	O	X
FILL T4 (FT)**	A	K	DUMP T4 (BHND)	G	N
FILL T4 (RR)**	#	K	DUMP T4 (BTWN)	B	X

* SET THE OUTER ARM TUBES LEVEL WHEN USING THE RETRACT POSITION.
 ** WHEN FILLING TANK 4, START AT REAR (RR) LID, THEN SWING INNER ARM TO FRONT (FT) LID WHILE ANCHORING CONVEYOR HOPPER.
 DECAL CODES ARE STARTING POSITION SETTINGS FOR INNER AND OUTER ARMS. (GUIDELINE ONLY)

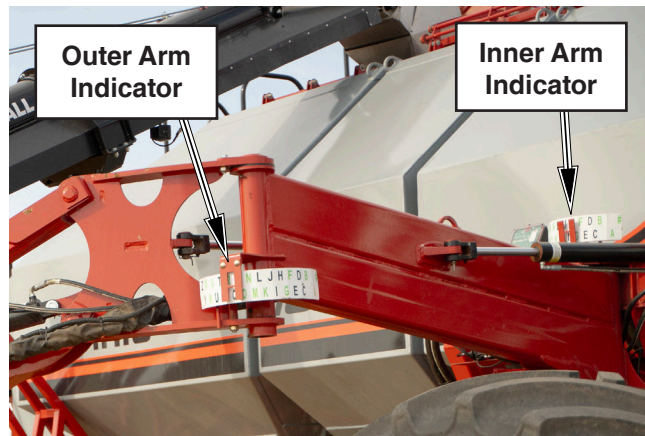

Conveyor - Continued

Transport Position



- First raise the parallel links lifting the conveyor off the ground while holding the tether strap to control conveyor position.
- Move conveyor close to cart by moving the inner and outer arms in.



- Fully raise conveyor on parallel links while holding the tether strap to control conveyor position.



- Extend the tilt cylinder a small amount to lower conveyor spout slightly to align with transport saddles. Put conveyor in horizontal position.



- Lower conveyor on parallel links into transport saddles.



- Switch conveyor valve to the "Lock/Unlock" position.

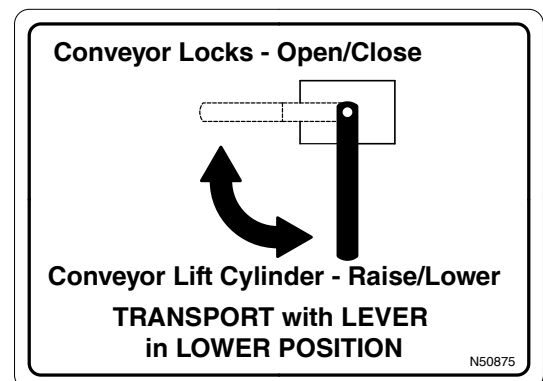
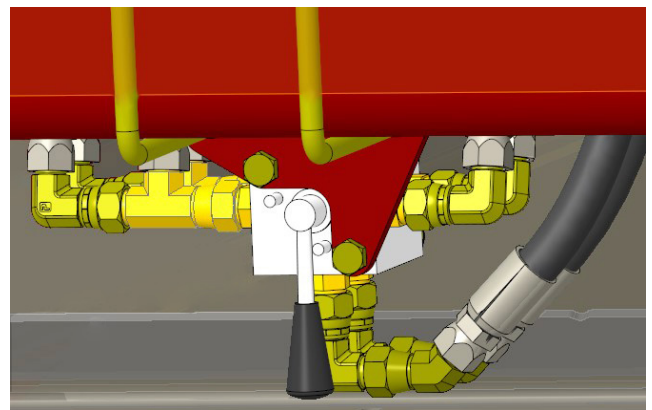
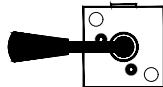

Operation

Conveyor - Continued

Transport Position - Continued

- Lock cradle pads on the conveyor by operating Lower button on the Transmitter.



- Check to ensure both locks are fully engaged before transporting.
- Switch conveyor valve to the “Lift Cylinder” position to lockout the hydraulics of the transport locks.

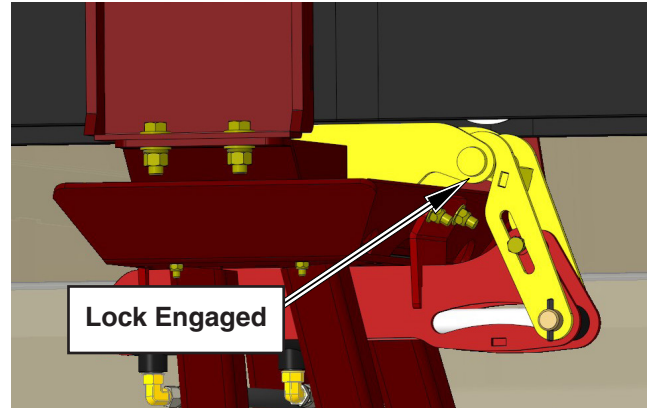
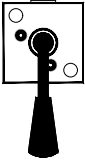

Conveyor - Continued

Conveyor Break-In

There is no operational restrictions on the conveyor when used for the first time.

The conveyor belt alignment is set at the factory, to track correctly without carrying a load.

Before Starting Work

1. Read conveyor Safety and Operation Sections of the manual.
2. Be familiar with the functions of the remote.
3. Run the conveyor for half an hour to seat the conveyor belt and hopper flashing. It is normal for rubber from the flashing to be expelled out the discharge and form a pattern on the belt.

Operating for first 1/2 hour

4. During the conveyors first few minutes of operation, check belt tension and alignment to ensure the factory preset does not vary under loaded conditions.
5. Check the flashing seal on the hopper. If any product comes out of the hopper around the flashing; stop the belt, loosen flashing mounting screws and adjust. Retighten anchor screws and try again. Repeat until no product is lost.
6. Check that all guards are installed and function as intended.

After Operating for 5 hours and 10 hours

Repeat steps 1 through 6 above.

Service and maintain the conveyor as defined in Maintenance Section.



Operation

Conveyor - Continued

Pre-Operation Checklist

Efficient and safe operation of the conveyor requires that each operator knows the operating procedures.

It is important for both the personal safety and maintaining the good mechanical condition of the machine that this checklist is followed.

Before operating the conveyor, and each time thereafter, the following areas should be checked.

1. Check worksite. Clean up working area to prevent slipping or tripping.
2. Lubricate and service the machine as per the schedule outlined in the Maintenance Section.
3. Check that all guards are installed, secured and functioning as intended. Do not operate with missing or damaged shields.
4. Check that the conveyor belt is properly tensioned and aligned. Ensure it is not frayed or damaged. Refer to the Maintenance Section.
5. Check that the discharge and intake hopper areas are free of obstructions.

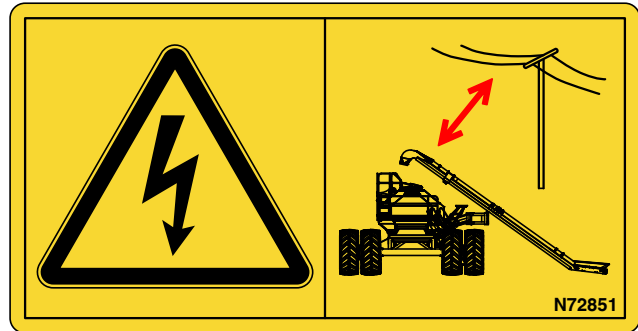

Operation Procedure

When operating conveyor, follow this procedure:

1. Clear the area of bystanders, especially small children, before starting.
2. Review the Pre-Operation Checklist before starting.
3. Keep all spectators and bystanders out of this work hazard area.
 - Should anyone enter the hazard area, stop the machine immediately.
4. Check that all guards are in place and working as intended.

Starting Conveyor:

5. Attach the hydraulic hoses from the external power supply.
6. Start the hydraulic flow to rotate the conveyor belt.
7. To start the flow of product and unload into the conveyor hopper. Feed the sir seeder.

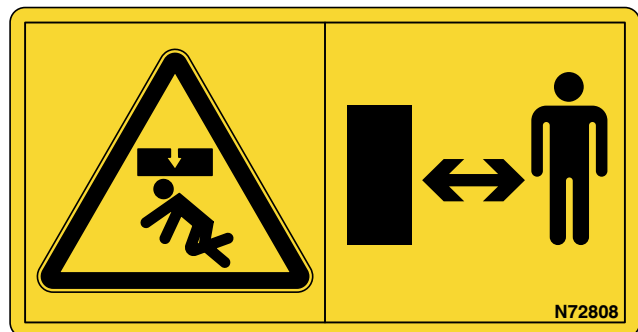

Conveyor - Continued

Operation Procedure

When operating conveyor, follow this procedure:

1. Clear the area of bystanders, especially small children, before starting.
2. Review the Pre-Operation Checklist before starting.
3. Keep all spectators and bystanders out of this work hazard area.
 - Should anyone enter the hazard area, stop the machine immediately.

4. Check that all guards are in place and working as intended.

Starting Conveyor:

5. Engage tractor hydraulics in correct direction for Conveyor operation on Fan 1 circuit.
6. Start the hydraulic flow to rotate the conveyor belt with remote.



Note: In cold weather, run empty conveyor for five minutes to warm up belt. Otherwise, do not operate the conveyor empty for long periods of time.

7. Start the flow of product and unload into the conveyor hopper.

Stopping Conveyor

1. Stop unloading product into the conveyor. Wait for conveyor belt to run empty.
2. Turn conveyor hydraulic system off.
3. Turn power source off.

Emergency Stopping

Although it is recommended that the tube be emptied before stopping, in an emergency situation, stop the motor immediately.

- See to the emergency.
- Correct the situation before resuming work.

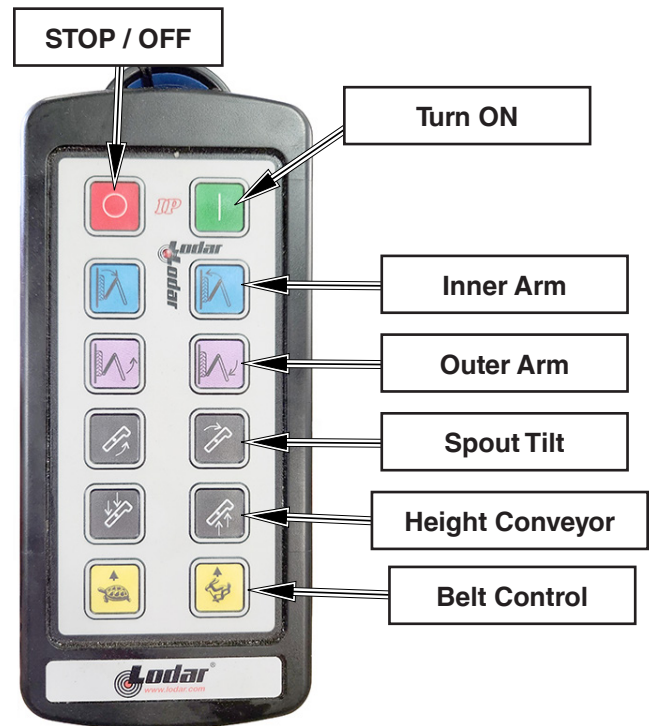

Operation

Conveyor - Continued

Operating Hints

- Keep the hopper full for maximum capacity. Most efficient results will be obtained when flow of incoming product is directed at the top of the hopper (Closer to the tube).
- Always listen for any unusual sounds or noises. If any are heard, stop the conveyor and determine the source. Correct the problem before resuming work.
- Do not run the conveyor for long periods of time with no product on the belting. This will increase wear. Run only when moving product.
- Do not support discharge end directly on the air cart.
- The hopper is designed with flashing to seal the junction of the belt with the sides of the hopper. It must be kept in good condition to prevent the material from “leaking” out of the hopper. Replace flashing if “leakage” occurs.
- Belt Speed:
The best results are obtained when the belt speed is 600 ft/min.
- Belt Tension
There may be a rapid decrease in belt tension during the first few hours of operation until the belt has worn in.
The correct operating tension is the lowest tension at which the belt will not slip under peak load conditions.
- Operating Angle:
The hydraulic lift can set the tube angle at any position between 12° and 30° when operating. Because the belt does not have roll-back barriers, the product will roll-back if the angle is too steep. Do not position at more than 30°.

Note: The lower the angle, the greater the capacity.



Conveyor - Continued

Optimizer Tank Filling

Below are 5 instructional illustrations on how to position the Conveyor for filling the Optimizer Tank.

Step 1: Swing outer arm away until Conveyor is past outside tire.

Step 2: Fully retract tilt cylinder and lower outer arm to about level position. Conveyor hopper should not be resting on the ground.

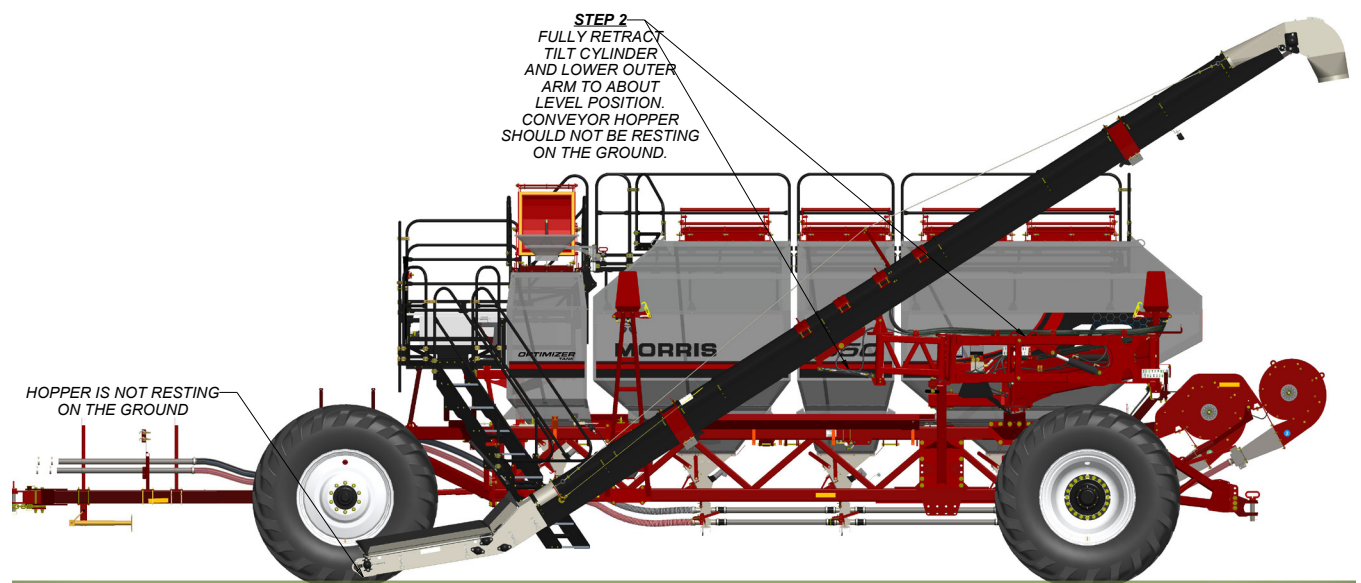
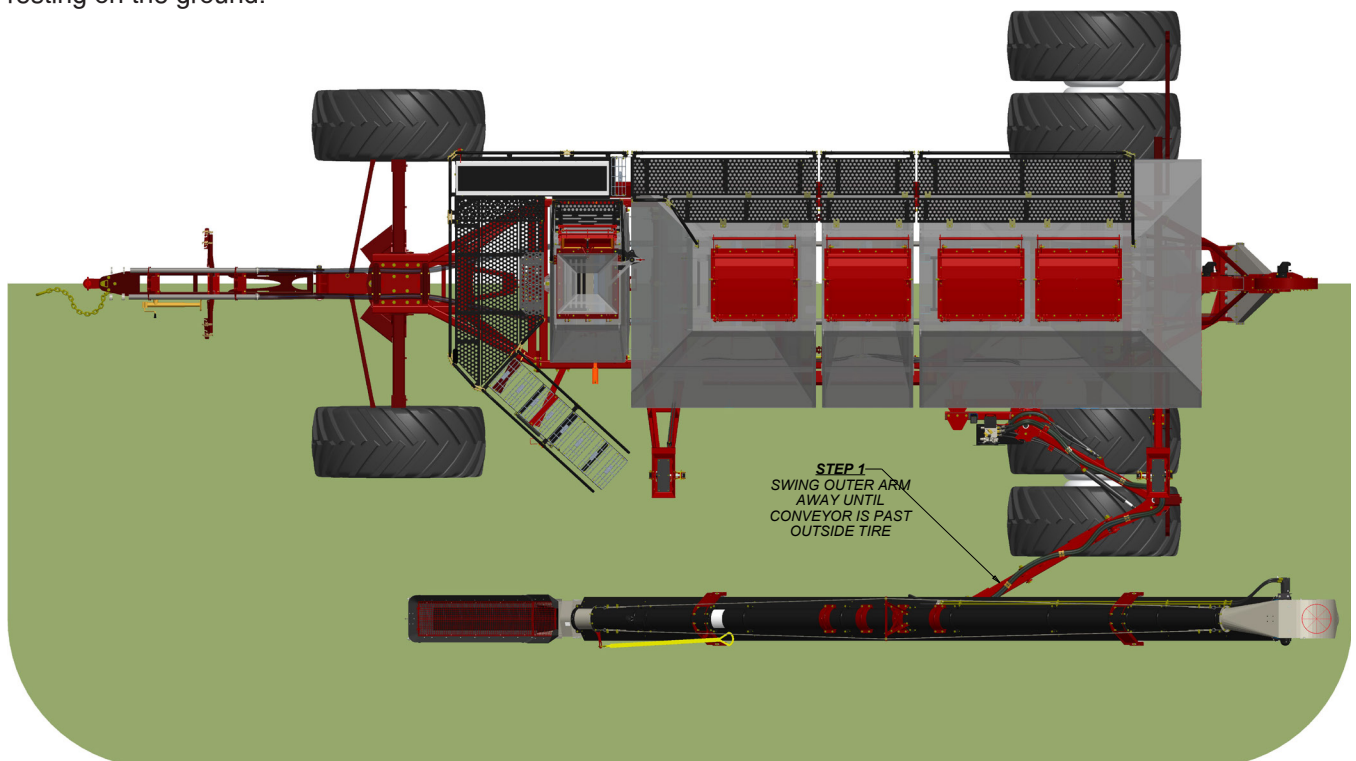

Operation

Conveyor - Continued

Optimizer Tank Filling - Continued

Step 3: With Conveyor still in maximum tilt position, swing inner arm to "O" on gauge and outer arm to "W" on gauge.

Swing Conveyor so that discharge is lined up with Optimizer Tank dump chute.

Note where truck dump will be.

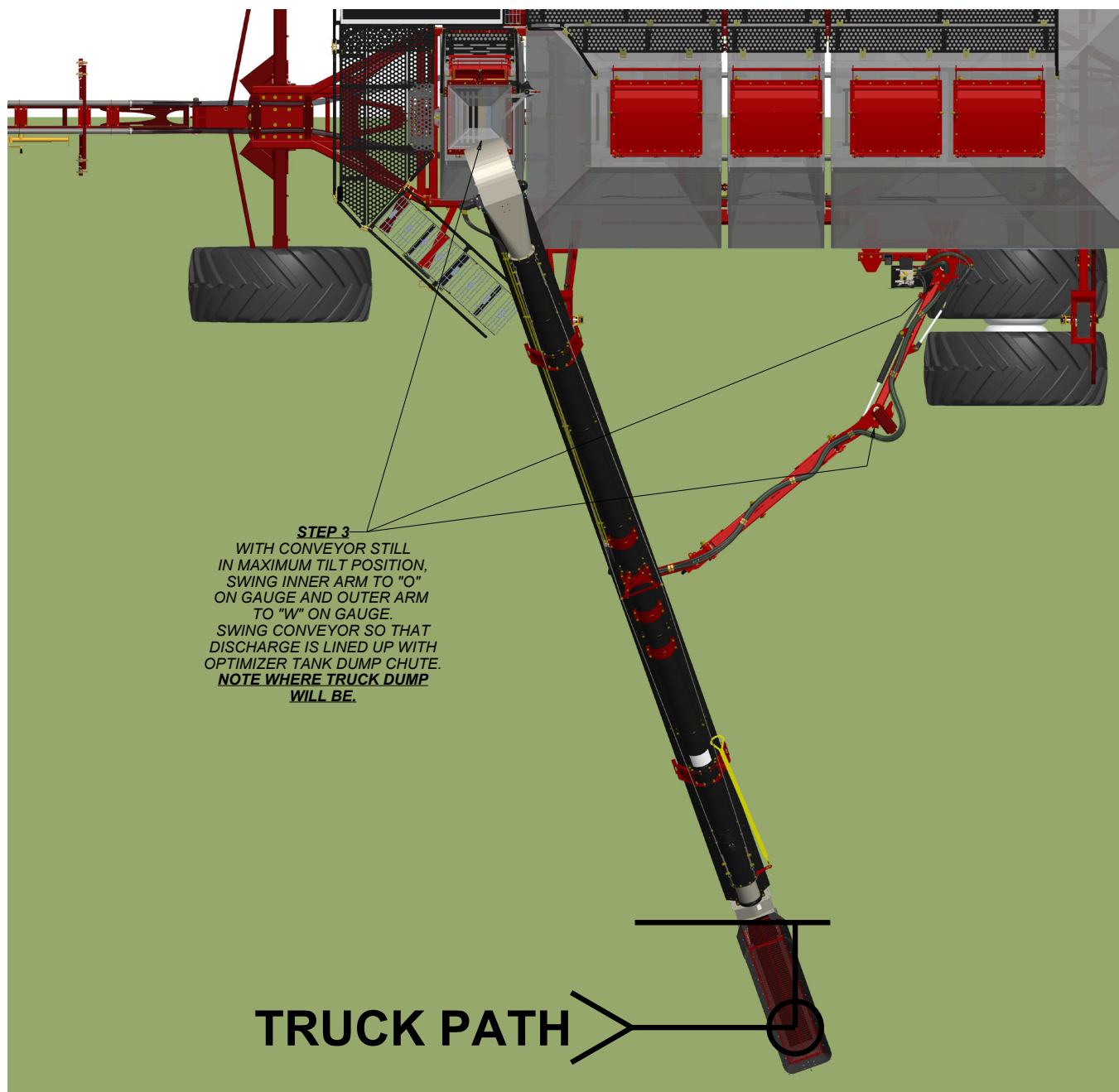

Conveyor - Continued

Optimizer Tank Filling - Continued

Step 4: With Conveyor still in maximum tilt position, lift outer arm fully and swing inward so that Conveyor retracts enough to clear incoming semi trailer.

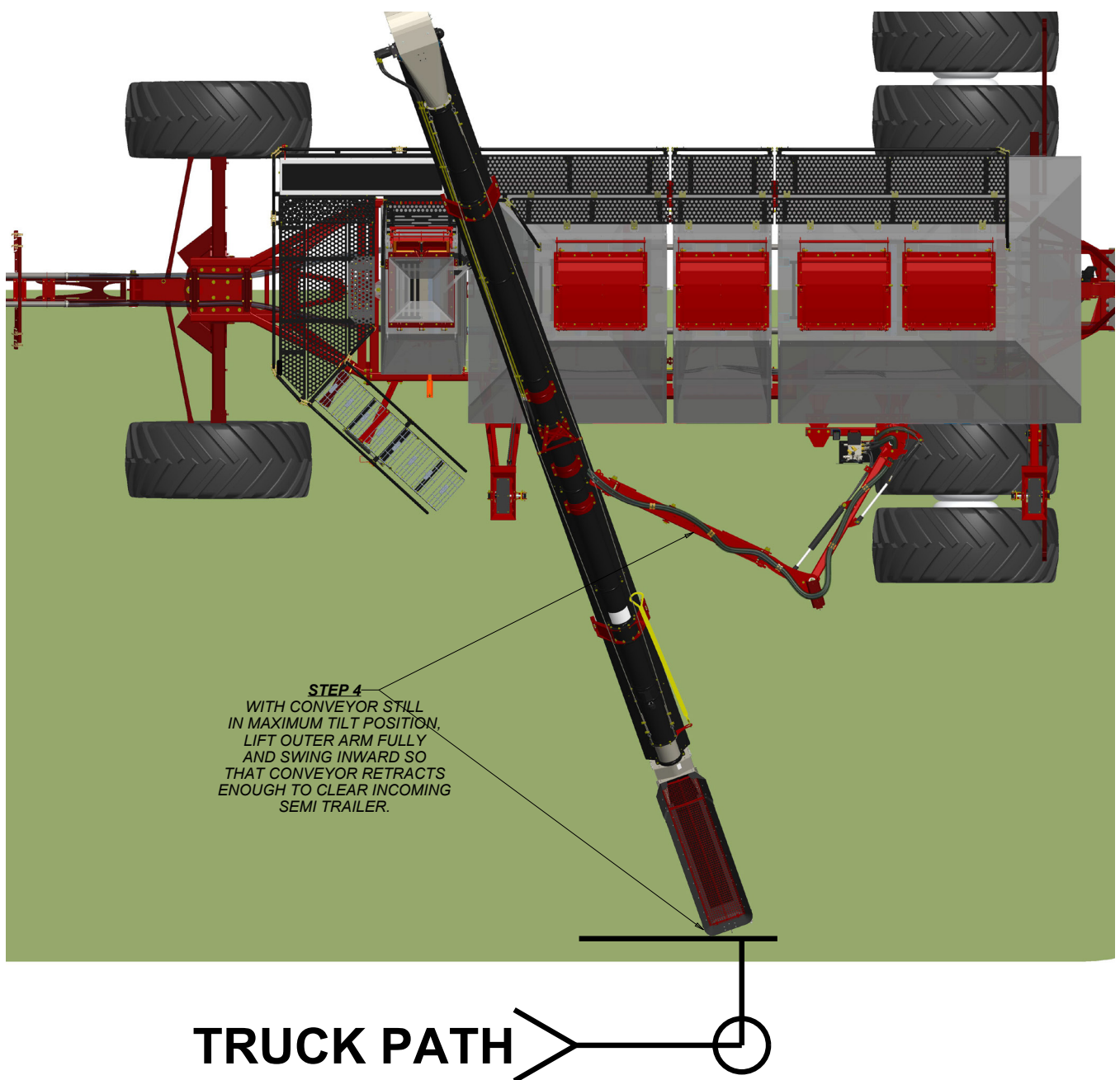

Operation

Conveyor - Continued

Optimizer Tank Filling - Continued

Step 5: Once semi trailer is positioned as required, lower and swing outer arm as required to hit both trailer dump and cart dump chute.

Note: Conveyor should be positioned directly over front cradle tower with adequate clearance.

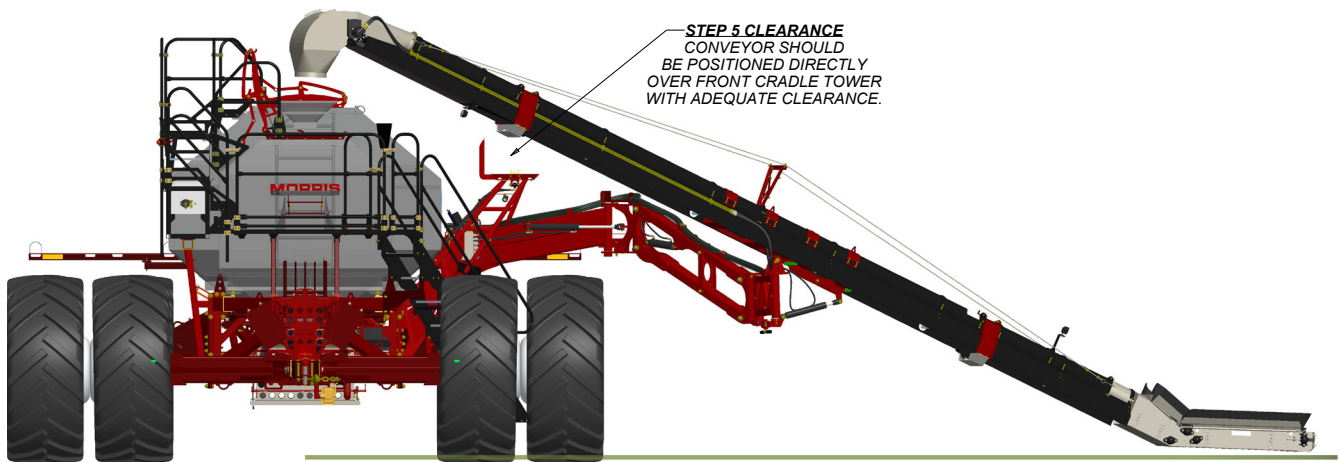
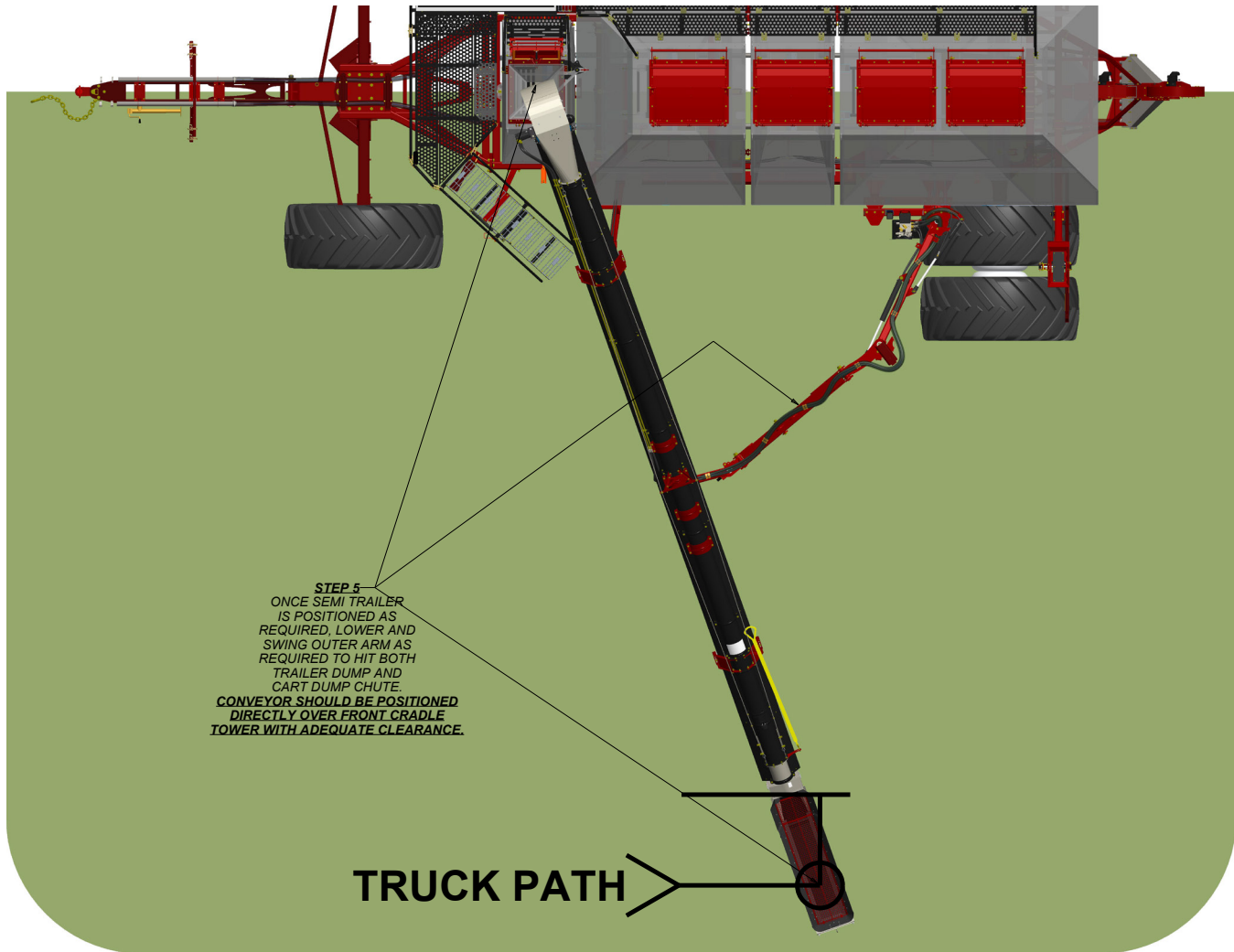

Filling Tank

The capacity of the air cart tanks are listed on the side of each tank.

- Ensure ALL fans are shut-off before opening lid.
- Open lid fully on tank being filled.
- Check and remove any debris inside tank.
- Open inspection door.
- Rotate seed plate fully open.
- Check for debris inside metering body.
- Ensure Tank Shut-Offs work freely.

Note: Tank Shut-Offs are only for use when inspecting/servicing meter body with product in tank.

- Check that the seed plate is set to correct position for the product being applied.
- Fully close and seal the inspection door.
- Ensure the conveyor screen is in place.
- Always use screen to filter debris when filling.

Note: Even small fertilizer lumps can cause problems with plugging. All possible precautions should be taken to prevent lumpy fertilizer from entering the tank.

Warning

Do not enter tank unless another person is present.

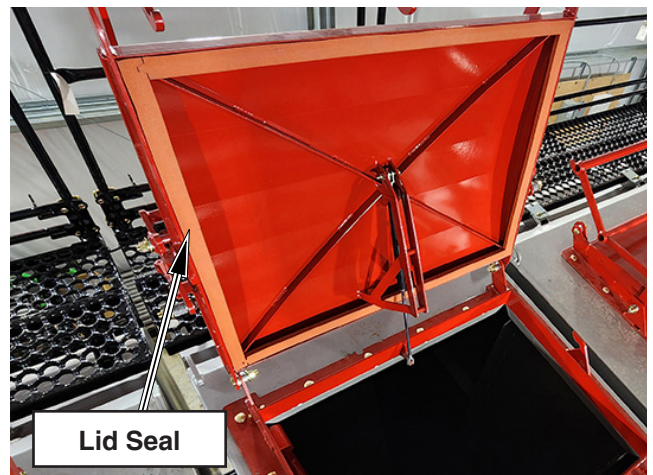

Important

Before putting product into the tanks check the following:

1. The seed plate is set to correct position for product being applied.
2. The inspection doors are fully closed and sealed.
3. Inspect all augers/conveyors used in handling the products. Run conveyor to clean out any debris inside conveyor so it does not get transferred to air cart tanks.

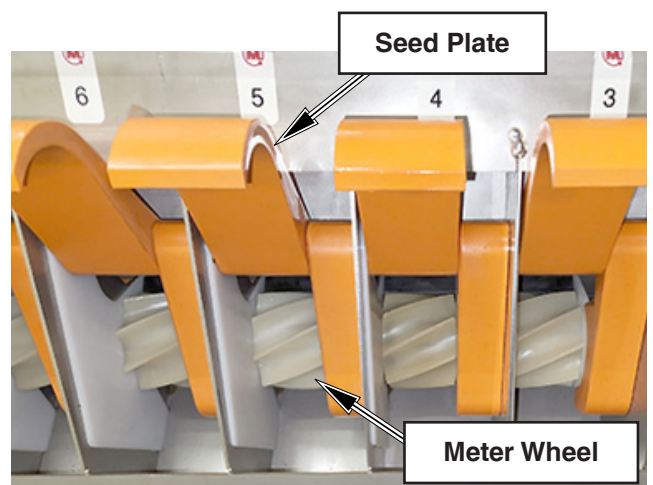

Ensure Metering is Free of Debris

Operation

Filling Tank - Continued

- One person must be in a position to monitor the operation of the conveyor at ALL times.
- Engage tractor hydraulics in correct direction for Conveyor operation on Fan 1 circuit.
- Switch conveyor power ON at the switch box.
- Turn ON the transmitter. Conveyor operation is controlled from the remote.
- Hold Tether Strap securely to control the position of the conveyor.
- Swing out the conveyor and place conveyor spout in tank to be filled.
- Position truck with the hopper and engage the hydraulic motor on the conveyor.
- Convey product into tank until desired level in tank is reached.
- Stop the flow of product into the conveyor and allow conveyor to empty.
- Clean lid seal and inspect for cuts, abrasions, debris in the seal and ensure the seal is positioned properly on lid seal surface before closing tank lid.
- Place conveyor in transport position securely lowered into cradles.
- Check lid for air leaks with your hands once air cart fan is operational. See Maintenance Section 7.
- Check metering body for air leaks. See Maintenance Section 7.

Note: Before seeding it is recommended that after a rain or dew that fan be run for a few minutes to eliminate moisture in the system.



Important

Do not exceed 10 mph (16 kph)
in field operation.



Unloading Tanks

Emptying tanks is quick and easy to do.

- Move flapper valves to “Clean-Out” position on the collector body. (Double Shoot Only)
- Open collector bottom.
- Position conveyor under the tank to be emptied.
- Start conveyor.
- Open Seed Plate Lever to the “Open” position, this will allow material to flow through the metering body into the conveyor.

Note: With Inspection Door closed the Seed Plate can be opened until it contacts door.

- Once all material stops flowing, move “Shut-off” levers in and out a few times to dislodge any product and ensure free movement.

continued on next page.

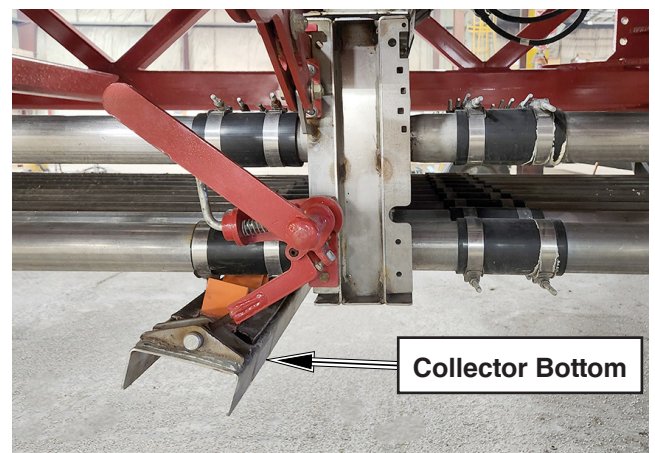
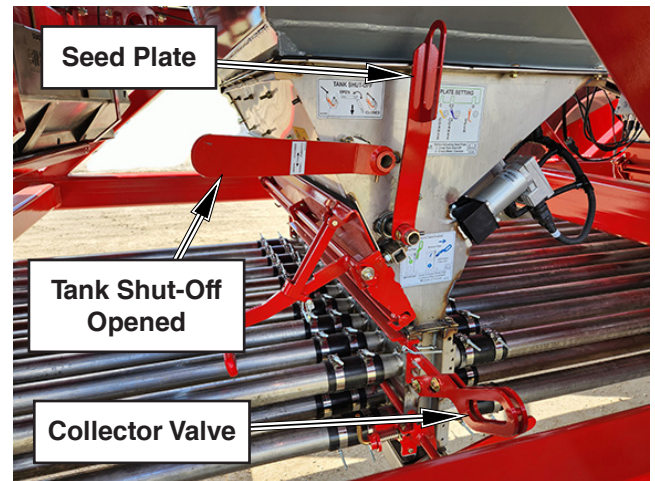

Operation

Unloading Tanks - Continued

- Open Inspection Door and rotate seed plate to fully open position.
- Open Pressure Chamber Covers and blow air around chamber to ensure it is free of debris.
- Brush out remaining material in the corners and on top of the back plate.
- Run meter drives to empty meter wheel flutes.
- Reset flapper valves to correct position for product delivery. Ensure that the flapper settings are correct.
- Set seed plate to correct position for product being metered.
- Install Pressure Chamber Covers ensuring that the seals are free from debris and leaks.
- Close inspection door and collector bottom ensuring that the seals are free from debris and leaks.

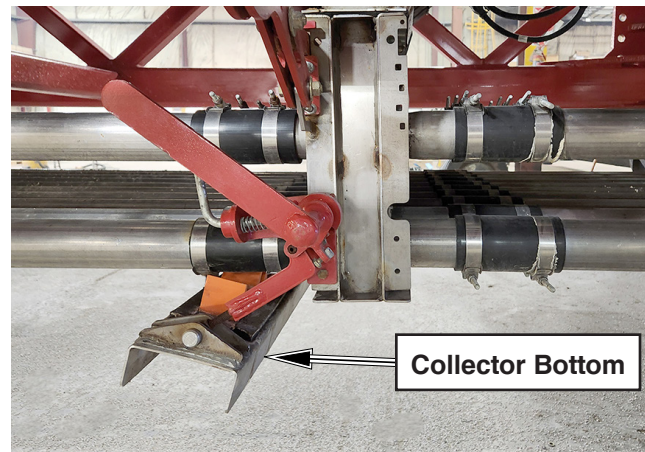
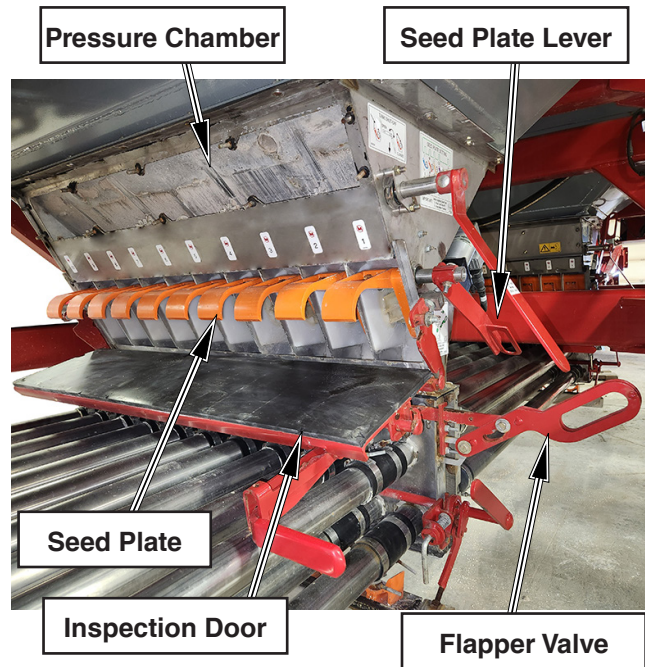

Danger

Keep all shields in place. Keep hands, feet and clothing away from auger intake, failure to do so will result in serious injury or death.

Rate Calibration

The practice of doing a rate calibration is strongly recommended, as it will confirm the **actual** amounts of product dispensed per motor revolution (**Weight/Rev**).

Weight/Rev (Calibration Factor) is used by the monitor to determine the shaft motor rpm required to deliver the correct application rate.

The following procedure should be followed for every change of product.

- Open collector bottom.
- Set Flapper Valves to “**Calibration**” (Bottom Pipe) as per collector valve decal.
- Remove rate check box from the storage bracket.
- Slide the rate check box onto the collector body.
- **Prime metering wheels first** by using the XD+ monitor. This monitor can pair with a Tablet or Smart Phone to the XD+ for remote calibration.

Note: The APU must be running to ensure correct voltage to motors is maintained.

Note: Ensure the fan is not running.

- Empty material from rate check box and reinstall it on the collector bottom.

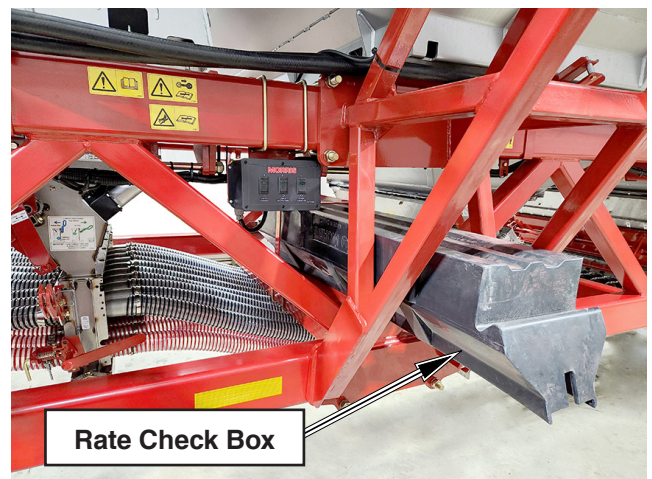
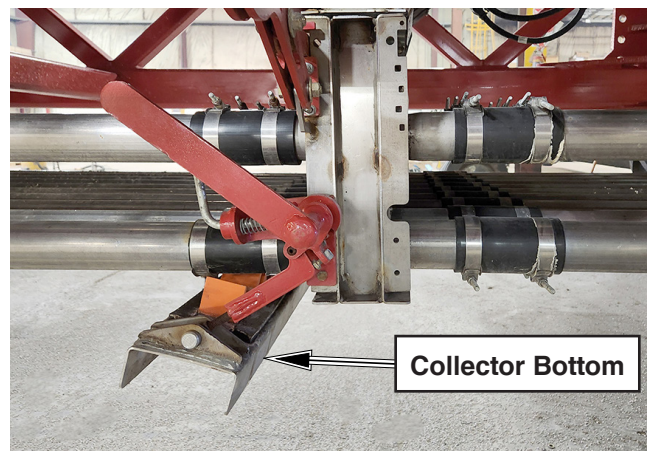

Rate Check Box Storage Location

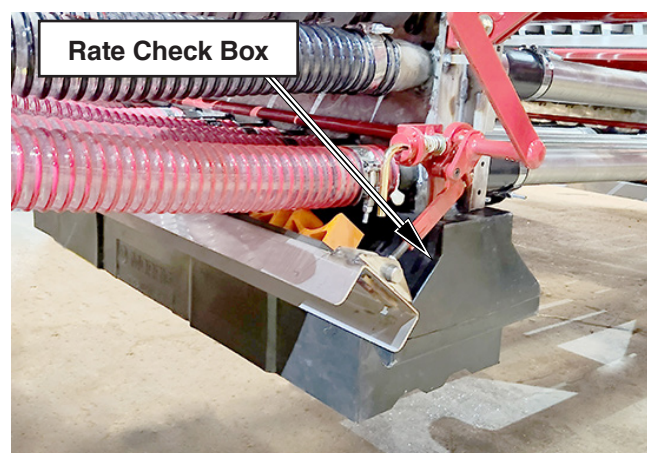

Operation

Rate Calibration - Continued

- Perform calibration as outlined in the XD+ Monitor manual.
- Remove the rate check box from the collector body.
- Hang scale from hook on front conveyor rest.
- Empty product from rate box into a pale and weigh.

Note: Remember to subtract the weight of the pale from the total sample weight.

- Enter “Weight” of product collected as outlined in the Topcon manual.

Note: The Calibration Factor (Weight/Rev) is automatically calculated for the value being entered.

- Close collector bottom ensuring that the seals are free from debris and leaks.
- Place rate check box into storage bracket and secure it with a tarp strap.

Follow the above procedure to check the rate of the other tanks.



Important

Proper measurement of sample weight is critical for application rate accuracy.

Prime metering wheels before taking actual sample.

Remember to subtract the weight of the pale from the total sample weight.



Metering Rate Adjustment

The metering rate adjustment for all tanks is done in the same manner. A new rate is achieved by changing the APPLICATION RATE and or the Calibration Factor as outlined in the Topcon XD+ manual.

Note: It is recommended to set “Calibration Factor” by doing a “Rate Calibration”.

Applying Inoculant

When inoculant is applied at the time of seeding, once the air cart has been filled, the fill-lids should be left open, and the fan run for 5-10 minutes at full rpm to dry the seed.

Calibration must be done after the seed is dried, otherwise the calibration will be incorrect.

Note: If the seed is not dried then the seed will have a tendency to bridge and not meter into the air stream.

Operation

Airguard Blockage Prevention System

Start Up Procedure

Start up procedure is critical to reduce pressure spikes.

After you have installed the Airguard Blockage Prevention System it's critical that you start the Aircart fans very slowly. You're introducing an air pocket that must be moved slowly to the tractor while you prime the hydraulic lines with oil. This process is a good way to make sure your fittings are sealed and secure.

1. Get tractor oil warmed to 100-110 deg F (38-43 deg C). If oil is cold, the viscosity is very high and it will not move through the internal components easily. By warming the oil first, everything will operate as it should.
2. Initiate fans at 500 Fan RPM - 25% oil flow (or 10% of max fan speed). If everything looks good, the pressure is just starting to register on the Airguard pressure gauge. If all your fittings are holding their seal, continue to the next step. If your fan is NOT moving, that's okay. The oil is circulating. **Operate this way for 5 minutes.**

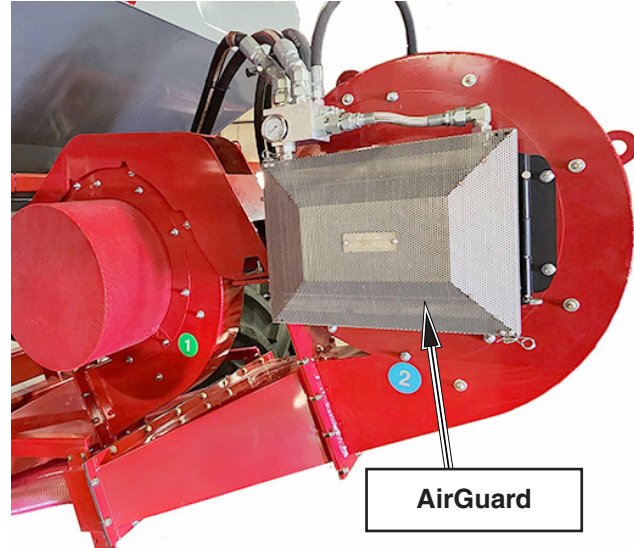

Note: If there is a pressure spike at this low oil flow rate, there is potential for an air lock. Disconnect the end fitting on the Return Line at the SCV and drain off some oil to release the pressure. Reconnect the end fitting and repeat Step 2.

3. Run 1000 Fan RPM at 45% oil flow (or 35% of your max fan speed). Operate for 5 seconds.
4. Run 2000 Fan RPM at 65% oil flow (or 75% of your max fan speed). Operate for 5 seconds.
5. Run 3500 Fan RPM at 85% oil flow (or 100% of your max fan speed). Operate for 3-5 minutes.
6. Take time to ensure that your conveyor or auger is working properly in conjunction with your Airguard kit. Turn the fan RPM down to 50% oil flow and engage the conveyor. If everything is operating as it should, you have successfully installed the Airguard Blockage Prevention System kit. If there are any questions or concerns about the operations, call your AIRGUARD Sales Representative using contact information found at www.airguardproducts.com/contact or visit us at www.airguardproducts.com/productsupport.

Now you're ready to operate! Follow the same warm up procedure you do every day and go seed. This is a procedure that we highly recommend at the beginning of each future season, to ensure the continuation of successful operations. It is a critical step in the introduction of new machinery to your farm operation. After the freeze and thaw of seasons we want to eliminate any air pockets or leaks that could slow preparations.

Preventative Maintenance

1. Ensure that the startup procedure above is performed every morning before seeding begins.
2. Take extra precautions when seeding in cold weather.

WARNING

AIRGUARD START UP PROCEDURE

For details on procedure visit airguardproducts.com

STEP 1 Turn **Airguard bypass** to 'HEAT OFF' position.
STEP 2 Run hydraulics on Tractor and Air Cart until hydraulic oil temperature is **100-110 deg F**.
STEP 3 Set hydraulic flow to fans to 'OFF' position in **TRACTOR**.
STEP 4 Turn **Airguard bypass** to 'HEAT ON' position.
STEP 5 Set fans to 500 RPM (25% oil flow). Operate for **10 MINUTES** & Check for oil leaks.
STEP 6 Set fans to 1000 RPM (45% oil flow). Operate for 5 seconds.
STEP 7 Set fans to 2000 RPM (65% oil flow). Operate for 5 seconds.
STEP 8 Set fans to 3500 RPM (85-100% oil flow). Operate for **5 MINUTES**.
STEP 9 Ensure conveyor / auger is working properly. Set fans to 1200 RPM (50% oil flow) and run.

You're ready to operate!

AIRGUARD

Questions? Call AIRGUARD Sales Representative.

Airguard Blockage Prevention System - Continued

Frequently asked questions

Q: Why can't I operate my Blockage Prevention System without warming up my tractor first?

A: Tractor motors and seeding equipment are built to withstand fast startups; an aluminum radiator is not. On a cold day at 10% oil flow, your return pressure could be at 500psi on our Blockage Prevention System. If you were to do a fast startup in cold conditions, you could have a radiator fail. Pressures could dramatically spike beyond the capacity of our 2400psi rated aluminum core.

Q: Will the Blockage Prevention System cause dramatic pressure drops in my oil flow?

A: While the BPS will cause a slight pressure drop (approximately 400 RPM or less), the drop in oil flow is negated because of the warm air being transferred from the oil into the airstream. This allows the internal product to flow more efficiently. The reason for the slight pressure drop is that the oil has to pass through the orifices of the radiator, which are smaller than the hoses used prior to the installation of the Blockage Prevention System.

Q: Does the Blockage Prevention System actually work?

A: We can honestly say that it does. The hotter the oil is in the hydraulic lines, the more heat the Blockage Prevention System can extract out of that oil. Since the mechanism is mounted on the face of the fan housing, the fan is pulling air through the fins of the radiator while the air cart is pressurizing up to operate. The hot oil, running through the radiator, acts like a furnace and changes the air temperature on the inside face of the radiator. That air is then pulled into the air cart stream and is pushed out towards the openers, where the seed is placed into the furrow. Warmer air holds more moisture. Humidity will stay in a vapor state when it is drawn in and will be less likely to turn into a liquid while the air and all the hoses and internal components are physically warmer. This allows the product to flow through with less resistance and minimizes buildup of dusty fertilizer internally. Seed and fertilizer will be delivered to the discharge outlets without problems.

Q: What pressure should the pressure gauge read on the Blockage Prevention System?

A: 300-600psi is an acceptable pressure range when operating. The gauge reads the pressure of the oil going through the radiator, on the return side of the fan motor.

Q: Do I need to reset the relief valves on the V2 Blockage Prevention System?

A: No you do not. The valves are preset to 750psi and 850psi. If they do get changed or altered, please contact Airguard in order to have them reset.

Airguard Blockage Prevention System Upgrade Instructions 2024-05-01

Operation

Hydraulic Fan Drive

The piston type orbit motor on the fan requires tractor to have either a load sensing hydraulic system or a closed center hydraulic system with flow control.

Each 19cc motor requires 25 U.S. gpm (95 lpm) at a pressure of 3,000 p.s.i. (20,684 kPa). However, smaller flows can be used depending on the product being metered.

Note: An additional 7.5 gpm (28 lpm) is required for the APU system.

Total hydraulic requirements is 58 gpm (220 lpm).

For correct operation of the fan the hydraulic motor must be coupled to the priority valve (if tractor is so equipped) in the hydraulic valve bank.

Check with the tractor manual or manufacturer to determine if or which spool is a "priority valve".

Speed fluctuations will result if the fan is not connected to the priority valve if hydraulic system is equipped with a priority valve.

Ensure couplers are free of dirt and are clean when connecting the fan hydraulics to the tractor.

Fan speed is adjusted by increasing the amount of oil being delivered to the motor by adjusting the respective flow control valve until the desired rpm is displayed on the monitor.

Note: Each motor has an internal one-way check valve. If the fan does not rotate, then move hydraulic lever in the opposite direction; this will engage the fan. This valve prevents damage to the hydraulic systems when the fan is shut OFF, by allowing the fan to freewheel.

There is an additional one-way check valve in fan circuit number 1. This provides hydraulic flow to the conveyor when the fan circuit is operated in reverse.

A piston motor creates leakage past the internal components for lubrication. This oil needs to go back to the oil reservoir at the lowest pressure possible. The motor has a 1/2" diameter case drain line. This line must be connected directly into the tractor hydraulic reservoir to ensure that there is zero back pressure in the drain line; otherwise damage will result to the motor.

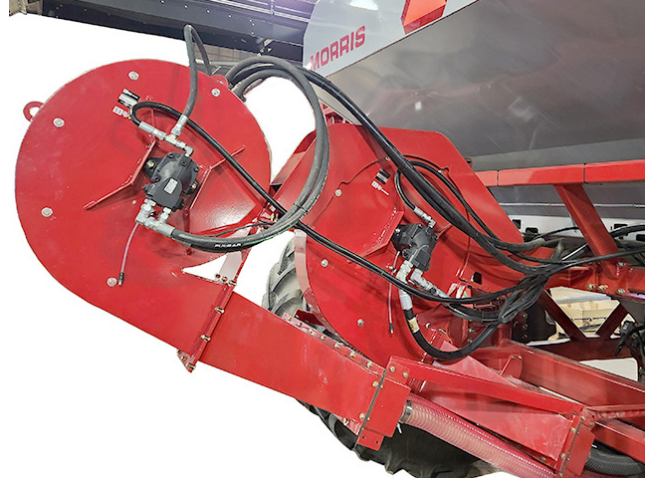

IMPORTANT

Run hydraulic fan drive at lowest rpm possible (500-1,000) for 5-10 minutes before operating at set rpm. This is required to warm up the hydraulic fluid. Cold hydraulic fluid will cause pressure spikes in the system that will damage the case drain seal in the orbit motor.

Note: AirGuard requires additional warm up.

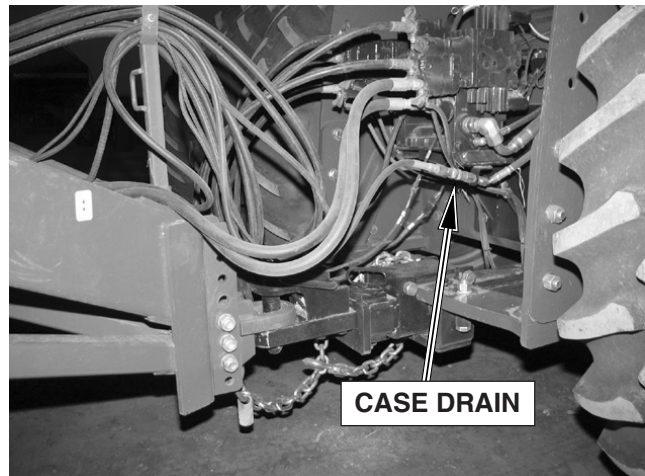

Hydraulic Coupling on Tractor

Fan Speed Recommendations

Adequate air volume is necessary at all times to carry the product in the air stream. Air volume can be controlled by adjusting hydraulic oil flow on hydraulic fan drives.

Air volume; hence fan speed requirements will vary with:

1. Ground speed
2. Metering rate
3. Number of primary runs
4. Secondary hose size
5. Width of machine
6. Density and size of material

Excessive fan speed can cause seed damage, seed bouncing and premature wear of the system.

Generally fan speed is adequate if product flows through the hoses without surging and the hoses empty quickly and evenly when the system shuts down.

Morris recommends the following operating guidelines for fan speed:

1. Do not operate the fan below 3000 rpm.
2. If equipped with dual fans, keep the speed difference between the two fans within 1000 rpm.

The charts on the next page list *suggested fan speeds* for various application rates.

Note: The charts should be used only as a guide. If plugging or surging occurs increase the fan speed to eliminate the problem.

Note: It is recommended that after a rain or dew the fan be run two to three minutes to expel any moisture in the system.

Important

Keep fan impeller blades clean at all times.

Note: Once fan speed is properly set, be sure to adjust the monitor fan alarm setting accordingly. Refer to Topcon XD+ manual.

Dual Fans

Use application rate of individual air stream to determine fan speed for that air stream.



Operation

Fan Speed Recommendations - Continued

Charts are based on a 40 foot machine traveling at 5 mph (8 kph).

Add rates of all products in the air stream.

22 inch Diameter Impeller Suggested Fan RPM @ 5 mph (8 kph) on a 40 ft unit	
Application Rate	Fan Speed
3 - 50 lbs/acre 3 - 56 kg/ha	3000 RPM
50 - 100 lbs/acre 56 - 112 kg/ha	3000 - 3150 RPM
100 - 150 lbs/acre 112 - 168 kg/ha	3150 - 3400 RPM
150 - 200 lbs/acre 168 - 224 kg/ha	3400 - 3650 RPM
200 - 250 lbs/acre 224 - 280 kg/ha	3650 - 3900 RPM
250 - 300 lbs/acre 280 - 336 kg/ha	3900 - 4150 RPM
300 - 350 lbs/acre 336 - 392 kg/ha	4150 - 4400 RPM
> 350 lbs/acre > 392 kg/ha	4400 - 4650 RPM
Note: Fan Speeds given are when applying product. It is normal for fan speed to drop when not applying product.	

Note: In a variable rate application set fan speed to match maximum product rate being applied.

Dual Fans

Use application rate of individual air stream to determine fan speed for that air stream.

Important:

Morris recommends not to operate the fan below 3000 rpm and if equipped with a dual fan setup to keep the speed difference within 1000 rpm.

Fan Speed Recommendations - Continued

Chart on a 70 foot machine traveling at 4.5 mph (7.2 kph).

Add rates of all products in the air stream.

22 inch Diameter Impeller Suggested Fan RPM @ 4.5 mph (7.2 kph) on a 70 ft unit	
Application Rate	Fan Speed
3 - 50 lbs/acre 3 - 56 kg/ha	3000 RPM
50 - 100 lbs/acre 56 - 112 kg/ha	3000 - 3250 RPM
100 - 150 lbs/acre 112 - 168 kg/ha	3250 - 3500 RPM
150 - 200 lbs/acre 168 - 224 kg/ha	3500 - 3750 RPM
200 - 250 lbs/acre 224 - 280 kg/ha	3750 - 4000 RPM
250 - 300 lbs/acre 280 - 336 kg/ha	4000 - 4250 RPM
300 - 350 lbs/acre 336 - 392 kg/ha	4250 - 4500 RPM
> 350 lbs/acre > 392 kg/ha	4500 - 4750 RPM
Note: Fan Speeds given are when applying product. It is normal for fan speed to drop when not applying product.	

Note: In a variable rate application set fan speed to match maximum product rate being applied.

Dual Fans

Use application rate of individual air stream to determine fan speed for that air stream.

Important:

Morris recommends not to operate the fan below 3000 rpm and if equipped with a dual fan setup to keep the speed difference within 1000 rpm.

Operation

Double Shoot Settings

Collector Valve Settings

Located in each upper collector body are flapper valves for machines equipped with Double Shoot. The flapper valve must be properly set in order for product to flow correctly.

Flapper valves must be cycled daily to free valves of any fertilizer and grain dust accumulations.

Whenever valves are cycled or reset to a new position the position should be visually inspected as follows:

- Set flapper valves to correct position for product delivery.
- Open the inspection door and visually check that the flappers are fully over and touching the side walls, sealing off the individual air streams.
- The flappers can be adjusted by loosening the individual adjusting setscrews and applying pressure to the flapper forcing it against the side wall while tightening the setscrew.

Note: The bottom air stream should be used to carry the higher rate of product.

Flapper Valve Run Test

Use the following procedure to check that the flapper valves do not move when air pressure is applied to under side of flappers.

- Check flapper valves in both directions with air running.
 - If valve is set to direct product into the bottom pipe, have the plenum damper open for the top pipes and closed to the bottom pipes.
 - If valve is set to direct product into the top pipe, have the plenum damper open for the bottom pipes and closed to the top pipes.
- **Always wear** safety goggles, breathing apparatus and gloves when working with granular chemical or treated seed per the manufacture's instructions.
- With fan running check flapper valve position.
- The flappers can be adjusted by loosening the individual adjusting setscrews and applying pressure to the flapper forcing it against the side wall while tightening the setscrew.

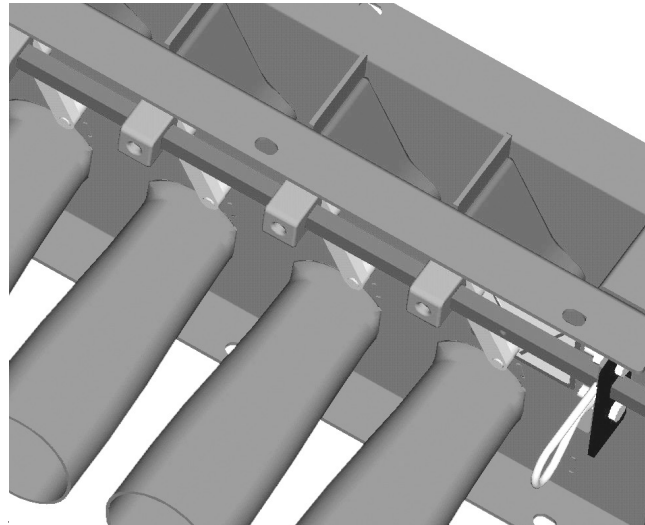

Flapper in "Bottom Pipe" Setting - Tow Behind

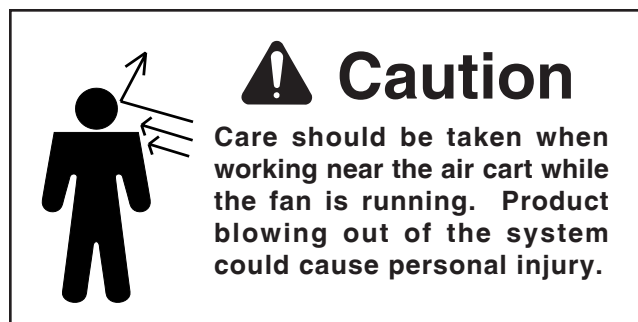
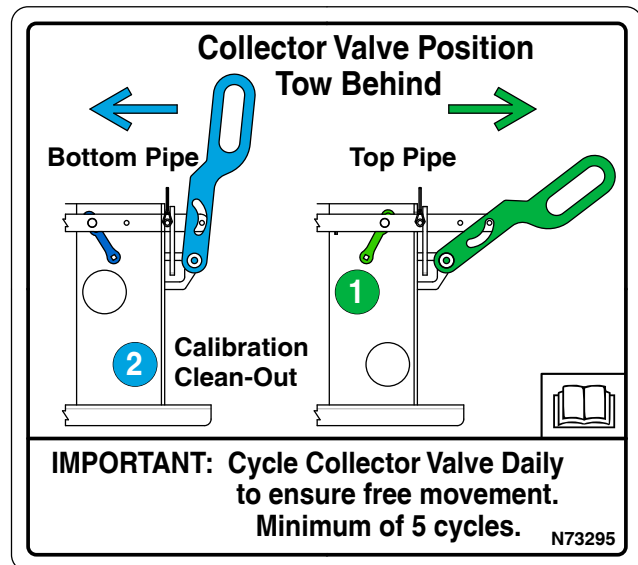

Operating Guidelines

There are a number of areas that can cause problems when seeding. Listed below are specific points that should be addressed at all times. Following these guidelines will ensure better crop emergence and consequently the potential for better yields.

Seed Rate Settings

- Remove any caked-on material from seed plate and metering wheels.
- Ensure correct seed plate is installed and metershaft turns freely.
- Check product rates carefully by performing a calibration check.

Note: It is strongly recommended to consult local agricultural extension offices for allowable product rates, which are dependent on soil moisture and type.

Fertilizer Application

- Avoid using fertilizers that absorb moisture readily, especially during periods of high humidity.
- Also avoid fertilizers that contain a high percentage of fine dust, as these materials can plug metering wheels and coat the inside of seed distribution system.

Fan Setting

- Run fan at recommended speed. If plugging or surging occurs increase the fan speed to eliminate the problem. If plugging or surging continues reduce ground speed to eliminate the problem.
- Allow tractor hydraulic oil to warm-up thoroughly prior to seeding. Cold oil will cause slower fan speeds (Hydraulic driven fan).

Note: Do not attempt to meter product when fan is not running. Damage to the metering wheels may occur.

Product Application

- Control product application with the XD+ monitor in tractor.
- Have machine moving forward before lowering seed boots to avoid plugging.
- To prevent skipping, allow a minimum of 15 feet (5 m) of forward travel to ensure air system has delivered product to seed boots.

Forward travel should be equal to half the width of the seeding tool. [i.e. for a 40 ft (14 m) wide seeding tool the forward travel should be a minimum of 20 feet (7 m).]

Travel Distance			
MPH	Feet/second	kph	m/s
3.75	5.50	6	1.67
4	5.87	6.44	1.79
4.25	6.23	6.84	1.90
4.5	6.60	7.25	2.01
4.75	6.97	7.5	2.08
5	7.33	8	2.22
5.25	7.70	8.5	2.36
5.5	8.07	8.85	2.46
5.75	8.43	9.25	2.57
6	8.80	9.66	2.68
6.25	9.17	10	2.78
6.5	9.53	10.46	2.91

Operation

Operating Guidelines - Continued

Checking Seed Flow

The following procedure should be implemented throughout the day typically at each fill of the air cart:

- Raise the seeding tool out of the ground.
- With the fan running and monitor on, engage meter drives, rotating each meter 4 to 5 times.
- Seed and/or fertilizer should appear at each outlet on the ground.
- If no seed or fertilizer appears on the ground at any of the openers check for hose blockage in both the secondary and primary hoses, as well as in the divider head.
- See Trouble Shooting Section for possible causes of the blockage.

Moisture Alert

- Whenever air cart has been standing for an hour or more during period of high humidity or damp, rainy days, or after sitting overnight, run fan at recommended rpm, with machine stationary for 5 minutes.

Air Leaks

It is imperative that no excessive air leaks occur in the air cart tank. Air leaks can lead to product bridging in the tank thereby causing misses in the field.

Check the following areas for air leaks:

- Tank lid
- Tank clean-out door
- Collector assembly seals
- Metering body assembly seals

Tank Low in Product

- Refill tank before metering wheels are exposed.
- The metering wheels must be completely covered to avoid unseeded strips.

Important

Check Metering Wheel flutes in the event the primary lines plug.

Flutes may shear if the collector becomes plugged.

Operating Guidelines - Continued

Monitor

- Familiarize yourself with all monitor functions as outlined in the Topcon XD+ manual.
- Ensure all monitor “*settings*” are correctly set for the air cart/seeding tool combination.
- Recognize and correct alarm conditions as indicated on the monitor.
- Check all wire harness connections for corrosion and use a dielectric spray to clean. Inspect all sensors for proper gap.



General Field Operation

- Follow guidelines outlined in “*Operating Guidelines*”.
- Switch monitor on as outlined in the Topcon manual.
- Start fans.

Note: Load sensing hydraulic systems require “*warming up*” before they function smoothly. See “*Hydraulic Fan Drive*” for more details.

- Move forward with seeding tool.
- Engage metering systems as outlined in the Topcon manual.
- Lower seeding tool into ground.
- Product rates can be varied as desired for the appropriate product as outlined in the Topcon manual.
- Turning at headland: Switch metering systems off with the XD+ monitor, immediately raise seeding tool, fully rephasing hydraulics (see seeding tool manual).
- Once turn is complete engage metering systems with the XD+ monitor and lower seeding tool into ground.

Note: Do not attempt to meter product when fan is not running. Damage to the metering wheels may occur.

Note: Engage meters early enough to avoid misses. Forward travel should be equal to half the width of the seeding tool. [i.e. for a 40 ft (14 m) wide seeding tool the forward travel should be a minimum of 20 feet (7 m).]

Operation

Notes

Section 6: Maintenance

Section Contents

General	6-2
Safety	6-2
Tighten Bolts.....	6-3
Tires.....	6-4
Daily Maintenance.....	6-5
Lubrication.....	6-6
Air Delivery System	6-7
General	6-7
Tank Lid Adjustment.....	6-8
Inspection Door Adjustment.....	6-9
Clean Out Door Adjustment.....	6-10
Air Leak Check.....	6-11
Fan	6-12
Rotor Clearance.....	6-13
Hoses.....	6-13
Equalizers	6-14
Fan Motor	6-15
Hydraulics.....	6-16
Wheel Bearings	6-17
Quad Steer	6-18
Dual Wheels	6-19
660 Cart - Rear Duals.....	6-19
1440 Cart - Front Duals	6-19
820, 1050 and 1440 Cart - Rear Duals.....	6-23
Rear Axle Extentions.....	6-26
Torque Rear Axle Hardware.....	6-26
Seed Plate Adjustment.....	6-27
Gearbox Removal / Installation.....	6-28
Auxiliary Power Unit (APU).....	6-30
Brakes	6-32
Fill Reservoir.....	6-32
Bleeding Brakes.....	6-32
Single Caliper Brake Bleeding.....	6-32
Dual Caliper Brake Bleeding.....	6-33
Brake Pads	6-34
Caliper Pistons and Seal Replacement	6-34
Conveyor	6-35
4.1 Fluids and Lubricants	6-35
4.2 Servicing Intervals.....	6-36
4.3 Maintenance Procedures	6-37

Maintenance

CAUTION



BE ALERT

SAFETY FIRST

REFER TO SECTION 1 AND REVIEW ALL
SAFETY RECOMMENDATIONS.

General

This section deals with two goals, maximum life and dependable operation. Adopt a regular maintenance and lubrication program. Care and sufficient lubrication is the best insurance against delays.

Safety

- Always shut off the tractor and remove key before dismounting.
- Guard against hydraulic high pressure leaks with hand and face protection.
- Never work under the implement unless it is in the down position or transport lock pins are in place and secured with hair pins. Do not depend on the hydraulic system to support the frame.
- Always wear safety goggles, breathing apparatus and gloves when working on seeder filled with chemical. Follow manufactures recommended safety procedures when working with chemicals or treated seeds.
- Do not feed left over treated seed to livestock, treated seed is poisonous and may cause harm to persons or livestock.

 **Warning**

Securely support any machine elements that must be raised for service work.

 **Caution**

Keep service area clean and dry. Wet or oily floors are slippery.





Tighten Bolts

- Before operating the air cart.
- After the first two hours of operation.
- Check tightness periodically thereafter.
- Use Bolt Torque Chart for correct values on various bolts.
- Note dashes on hex heads to determine correct grade.

Note: DO NOT use the values in the Bolt Torque Chart if a different torque value or tightening procedure is given for a specific application.

- Fasteners should be replaced with the same or higher grade. If higher grade is used, only tighten to the strength of the original.

Bolt Torque Chart				
Grade 5 Bolt Marking 		Bolt Size	Grade 8 Bolt Marking 	
Nm	lb-ft		lb-ft	Nm
11	8	1/4	12	16
23	17	5/16	24	33
41	30	3/8	45	61
68	50	7/16	70	95
102	75	1/2	105	142
149	110	9/16	155	210
203	150	5/8	210	285
366	270	3/4	375	508
536	395	7/8	610	827
800	590	1	910	1234
1150	850	1-1/8	1350	1850
1650	1200	1-1/4	1950	2600
2150	1550	1-3/8	2550	3400
2850	2100	1-1/2	3350	4550

Important

Retorque wheel nuts after first fifteen minutes of operation and every fifteen minutes for the next 2 hours. Check periodically afterwards.

Wheel Bolt Torque	
SIZE	Torque
22 mm	500 lb-ft (678 Nm)
** 24 mm	590 lb-ft (800 Nm)

** Refer to “Dual Wheel Rims” for details.

Maintenance

Tires

- Inspect tires and wheels daily for tread wear, side wall abrasions, damaged rims or missing lug bolts and nuts. Replace if necessary.
- Tighten wheel bolts - refer to Wheel Bolt Torque Chart.
- Check tire pressure daily, when tires are cold.
- Correct tire pressure is important.
- Do not inflate tire above the recommended pressure.



Caution

Tire replacement should be done by trained personnel using the proper equipment.

Tire Pressure		
Model	Tow Between	
	VF710/70R42 CFO CEAT	VF900/60R42 CFO CEAT
	Rear Dual	Rear Dual
660	18 psi 124 kPa	15 psi 104 kPa
820	22 psi 152 kPa	17 psi 118 kPa
1050	***	21 psi 145 kPa

Tire Pressure					
Model	Tow Behind				
	VF710/70R42 CFO CEAT		VF900/60R42 CFO CEAT		IF850/75R42 CFO CEAT
	Front Tire	Rear Dual	Front Tire	Rear Dual	Rear Dual
660	12 psi 83 kPa	12 psi 83 kPa	12 psi 83 kPa	12 psi 83 kPa	***
820	13 psi 90 kPa	16 psi 111 kPa	12 psi 83 kPa	13 psi 90 kPa	***
1050	17 psi 118 kPa	21 psi 145 kPa	13 psi 90 kPa	16 psi 111 kPa	***
1440	12 psi 83 kPa Duals	***	***	***	19 psi 131 kPa

Important: Tire pressures are based on CFO ratings at 6 mph (9.7 Kph).

Tire damage may occur if towed at higher speeds and loaded with product.

Increase tire pressures by 25 percent for higher speeds.

Daily Maintenance

- Check for and remove any water in primary collectors and pressure lines after rainy weather. Remove all inspection doors and collector bottoms to drain water from the tanks and collectors.
- Reinstall collector bottoms and inspection doors.
- Ensure fan screens are clear of debris.

Note: Start fan and run for 3 - 5 minutes prior to loading machine to get rid of accumulated moisture.

- Check lid seals for damage, and that they are sitting properly on steel ring.
- Check the pressure chamber and inspection door chamber for dust build up. Clean out and remove any excess buildup of dust between the seed plate and the inspection door.
- Check tank pressure hoses for leaks, cracks or plugging.
- Check the following areas for air leaks:
 - Tank inspection door
 - Metering body assembly seals
 - Collector assembly seals
 - Tank lid

Refer to "Air Leak Check" under Air System Maintenance.

- Check monitor wiring that all sensor wires are properly routed and retained.
- Check for plugged hoses.
- Cycle Collector Valve five times to ensure parts are free to move.
- Ensure drive chains are cleared of debris.
- Check torque on wheel bolts.

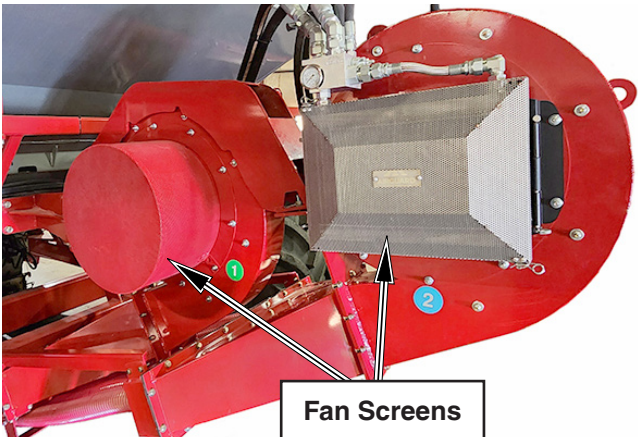
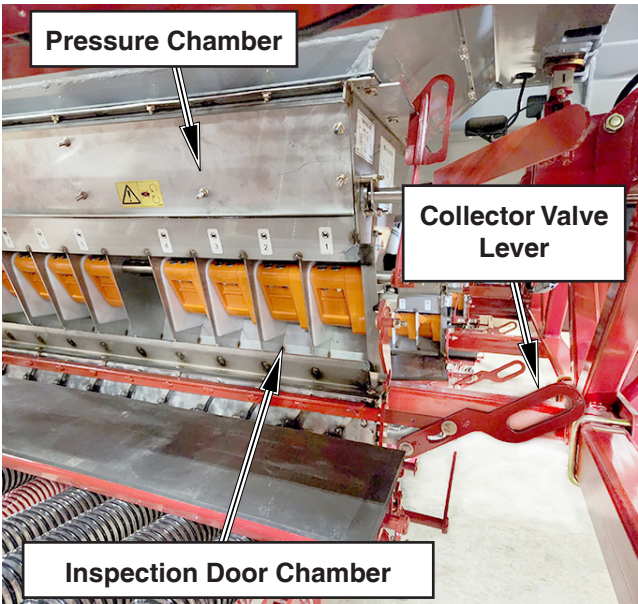
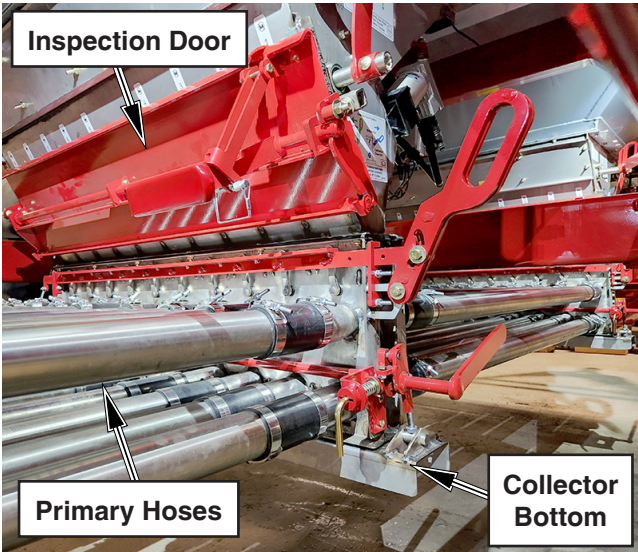
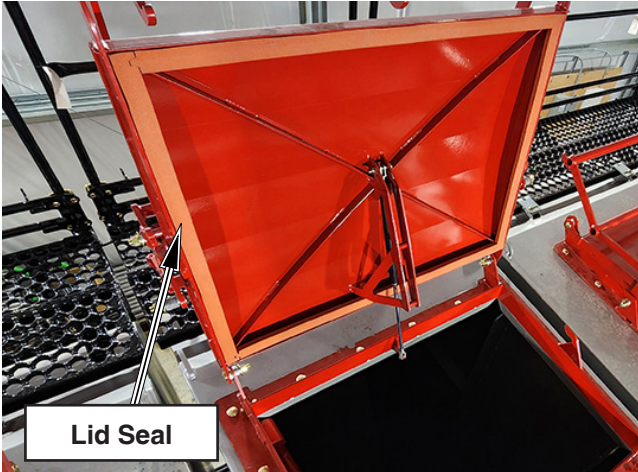

Maintenance

Lubrication

Greasing pivot points prevents wear and helps restrict dirt from entering. However, once dirt does enter a bearing, it combines with the lubricant and becomes an abrasive grinding paste, more destructive than grit alone.

- Apply new lubricant frequently during operation to flush out old contaminated lubricant.
- Use a good grade of **lithium based grease**.
- Use a good grade of machine oil.
- Clean grease fittings and lubricator gun before applying lubricant.

Refer to the following photos for grease fitting locations.

1. Hitch Clevis Ball (Tow Between)

- Grease every 10 hours.

2. Hub Bearings

- Grease every 50 hours.

3. Conveyor Bearings (See Conveyor Maintenance)

- Grease every 50 hours.

4. Conveyor Arm Pivots

- Grease every 100 hours.



2. Hub Bearings

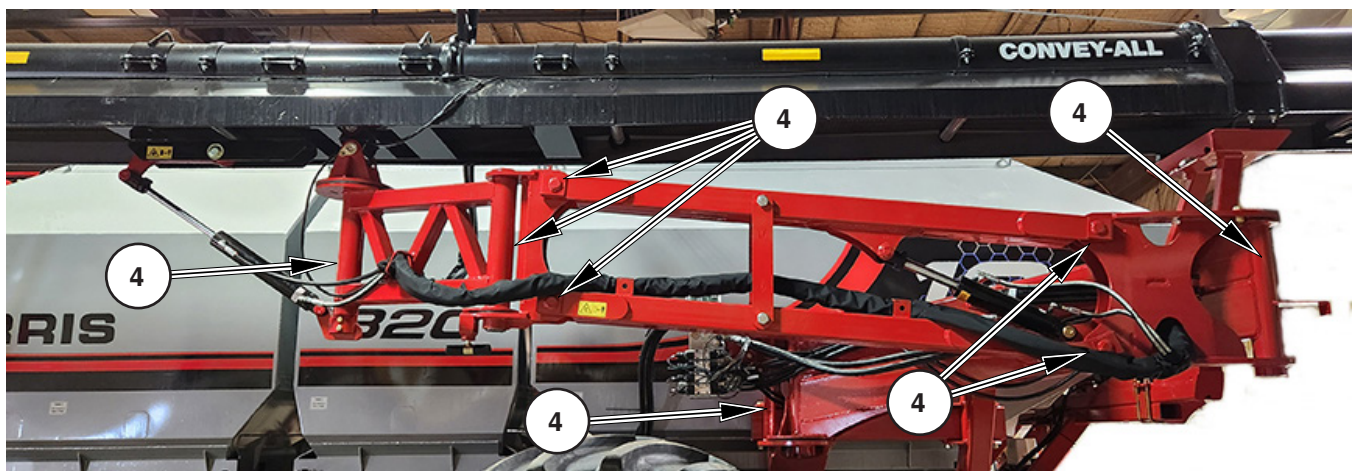

Air Delivery System

General

The air delivery system of all air carts is extremely important for the proper metering of product to the openers. The metering system on all pressurized air carts is sensitive to air leaks. **Loss of tank air pressure could affect feed rates, which could become erratic or even stop.**

- Regularly check that all hoses are free from kinks or blockages throughout the day. To check for blockages raise seeding tool out of the ground and with the fan running engage meter drives with the Start/Stop button, rotating meter drives 4 to 5 times. Equal amounts of material should be deposited under each boot. If not, check the following for blockage:
 1. Seed openers and secondary hoses.
 2. Divider heads.
 3. Primary hoses and collectors.
 4. Metering wheels for damage to the flutes of the wheel.
- Keep fan inlet screen clear and free from debris.
- Place a plastic bag over the fan when the unit is not in use. This helps prevent moisture from entering the system.
- Check periodically and at the end of each season for air leaks at hose connections.
- Check periodically and at the end of each season for air leaks in the following areas:
 1. Tank lid seals.
 2. Metering body shaft seals.
 3. Metering body to tank seals.
 4. Collector to metering body seals.
 5. Fan to plenum.
 6. Plenum to collector.
 7. Inspection doors, for leaks and loss of seal memory.
 8. Collector door seals.
 9. Couplers between air cart and seeding tool.
 10. Access doors on divider heads.

Note: There must not be any excessive air leaks from the tank. This air leakage causes air turbulence in the tank which can result in inaccurate metering rates.

- Once a year check for wear of primary and secondary hoses.

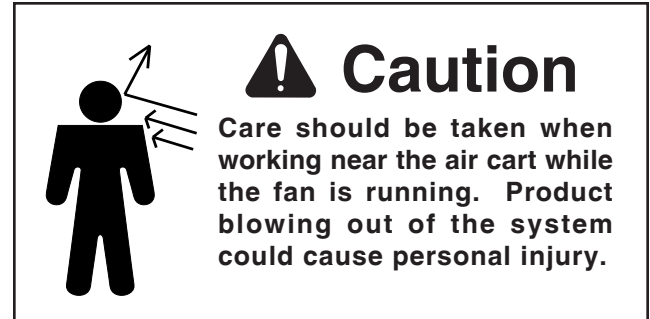

Note: Extended life can be obtained if the hoses are rotated 1/4 turn once a year.

Maintenance

Air Delivery System - Continued

Tank Lid Adjustment

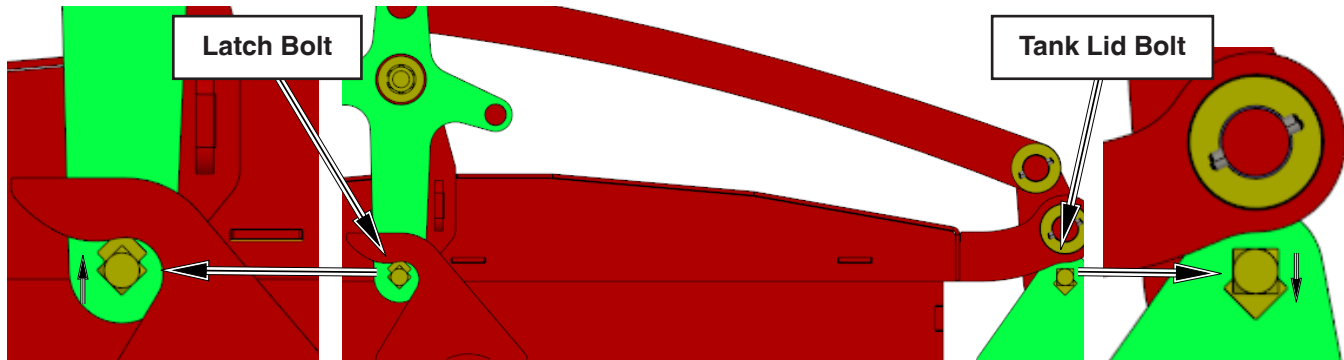

Check Tank Lid on *all tanks* at beginning of each season and periodically during season for air leaks. The following checks and adjustments must be made to prevent air leaks from occurring:

- Check for any foreign material embedded into seal. Clean out foreign material from seal surface.
- Check seal for cuts and abrasions. If seal is cut or severely worn, then replace seal.
- Ensure seal is positioned properly on lid seal surface with no gaps in corners between seal sections.
- Check for air leaks around tank lids with lids closed and fans running.
- If leaks are found, turn off fans and adjust latch bolts to provide more compression of seals and retest for leaks.
- To adjust lids tighter, position the carriage bolt into alternate slot position as shown.
- Move tank side carriage bolt **down** and latch side carriage bolt **up** to tighten (arrows).

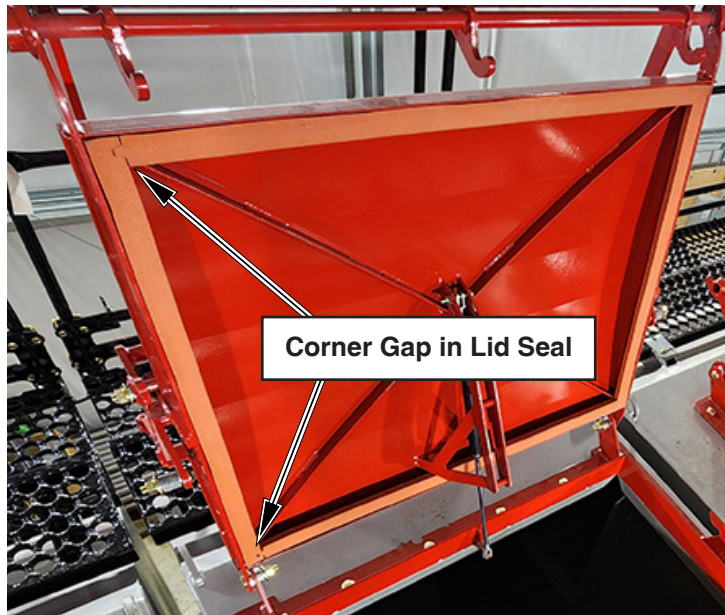
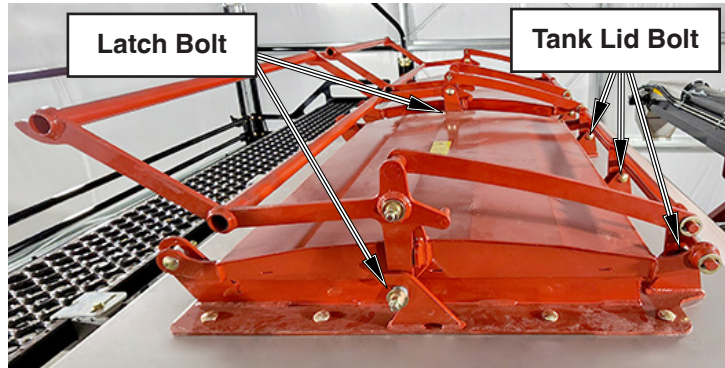

Important

The product will not meter correctly if the lid is not tightly sealed or the tank is not pressurized.

Note: When air cart is not in use, leave lid latches loose to help maintain resilience of the seals.

Air Delivery System - Continued

Inspection Door Adjustment

Check Inspection Door on *all metering bodies* at beginning of each season and periodically during season for air leaks. The following checks and adjustments must be made to prevent air leaks from occurring:

- Check for any foreign material embedded into seal. Clean out foreign material from seal surface.
- Check seal for cuts and abrasions. If seal is cut or severely worn, then replace seal.
- Ensure seal is positioned properly on steel rim around tank opening.
- Use a 0-100 lb. (0-45 kg) spring scale to check the door closing force. With the Door near the closed position, place one end of the scale *on* the Door handle. Pull down on the scale and note the maximum force it takes to latch handle lock. The force needed to latch handle lock **must be 30 lbs (14 kg)**.
- Adjust the door latch adjusting bolts as necessary. This will ensure that the lid is sufficiently tight and prevent any leaks.
- Re-check for leaks. If Doors still leak adjust latch bolts one or two more turns. Re-check for leaks.

Important

The product will not meter correctly if the inspection door is not tightly sealed or the tank is not pressurized.

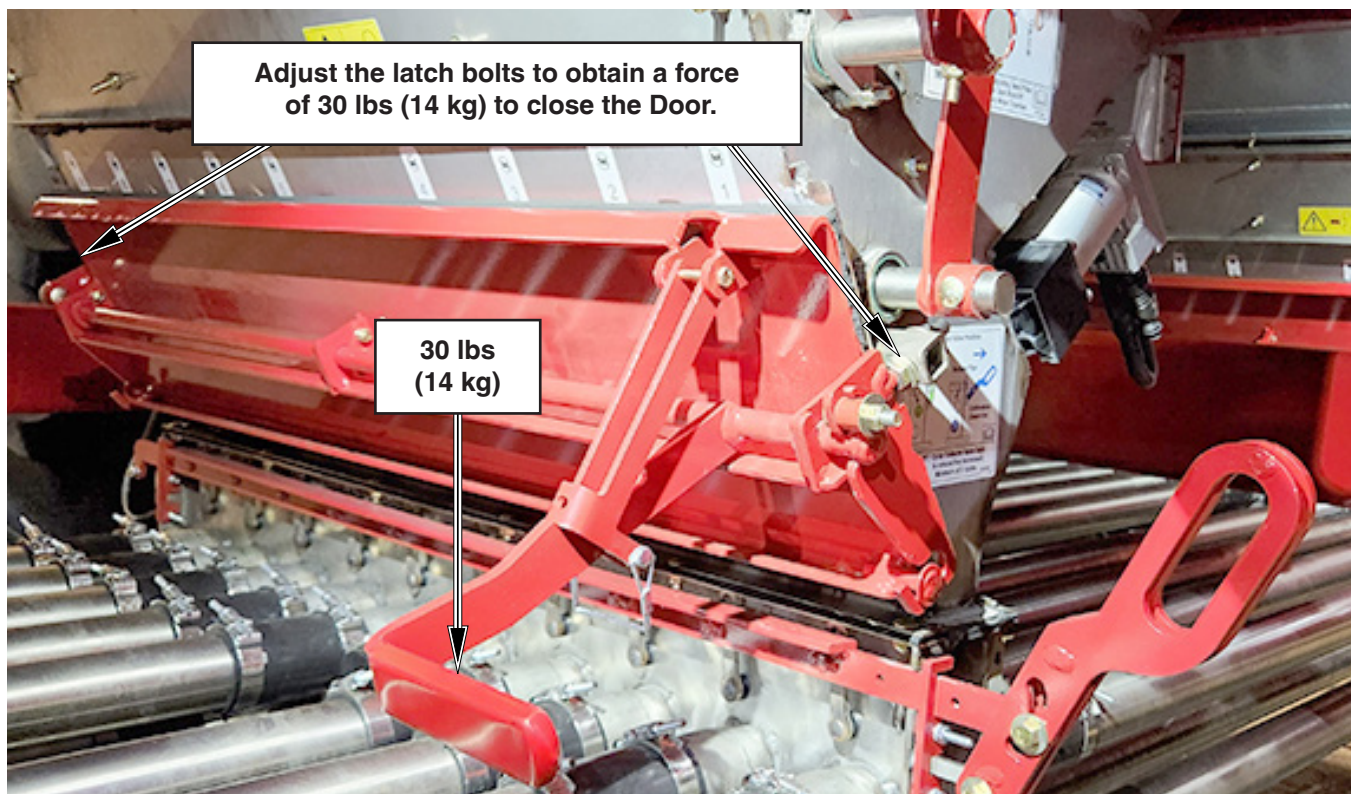

Maintenance

Air Delivery System - Continued

Clean Out Door Adjustment

Check Clean Out Door on all metering bodies at beginning of each season and periodically during season for air leaks. The following checks and adjustments must be made to prevent air leaks from occurring:

- Check for any foreign material embedded into seal. Clean out foreign material from seal surface.
- Check seal for cuts and abrasions. If seal is cut or severely worn, then replace seal.
- Ensure seal is positioned properly on steel rim around tank opening.
- Use a 0-100 lb. (0-45 kg) spring scale to check the Door closing force. With the Door near the closed position, place one end of the scale on the Door handle. Pull down on the scale and note the maximum force it takes to latch handle lock. The force needed to latch handle lock **must be 30 lbs (14 kg)**.
- Adjust the door latch adjusting bolts as necessary. This will ensure that the lid is sufficiently tight and prevent any leaks.
- Re-check for leaks. If Doors still leak adjust latch bolts one or two more turns. Re-check for leaks.
- In the open position, adjust the adjusting bolts as necessary to hold collector door away from the collector bottom.

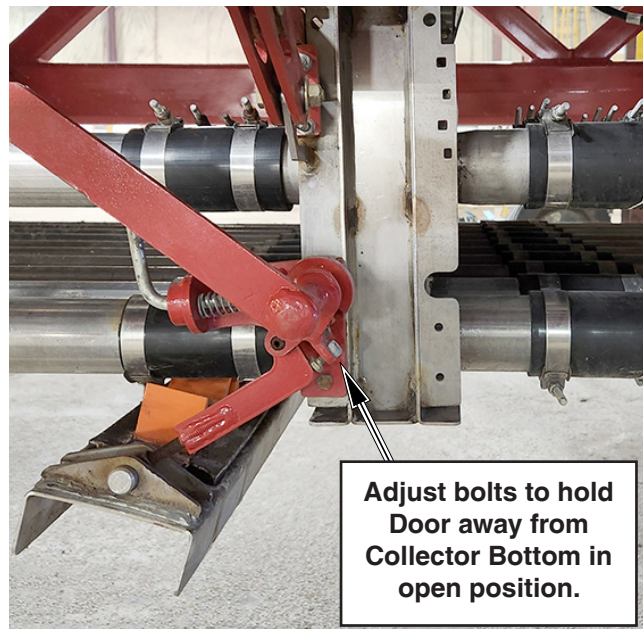
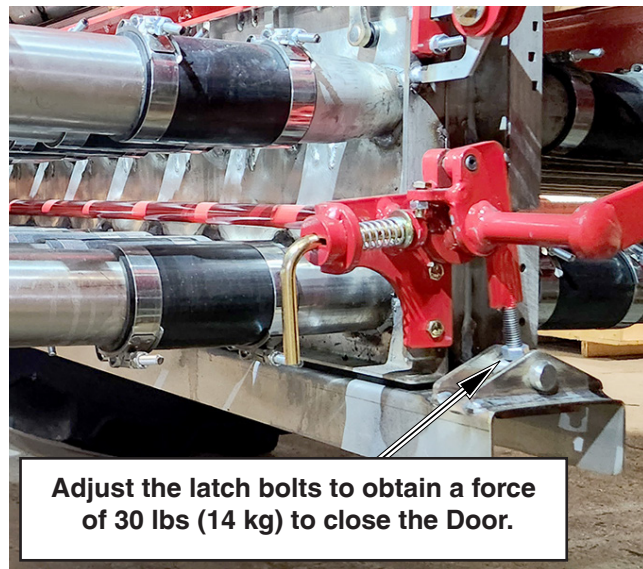
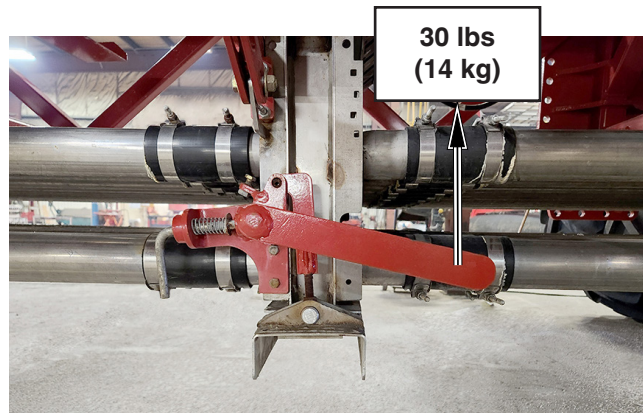

Important

The product will not meter correctly if the clean out door is not tightly sealed or the tank is not pressurized.

Air Delivery System - Continued

Air Leak Check

It is **imperative that no excessive air leaks occur** in the air cart tank. Air leaks could cause loss of tank air pressure affecting feed rates, which could become erratic or stop.

To prevent this from occurring, it is strongly recommended that a pressure test be conducted prior to seeding time. This can be performed very easily and simply by completing the following steps:

- Clean fan impeller and adjust tank lids.
- Disconnect the 2 1/2" diameter primary hoses from the rear of the seeding tool at the primary hose couplers.
- Install the blank off plate that is supplied with the air cart at each coupler. If the blank off plates are not readily at hand a piece of cardboard can be used in its place.
- Once the blank off plates have been installed, start the fan and run at 4,500 rpm.

Check the following areas for air leaks:

1. Tank lid seals.
2. Metering body shaft seals.
3. Metering body to tank seals.
4. Collector to metering body seals.
5. Fan to plenum and plenum to collector.
6. Inspection doors, for leaks and loss of seal memory.
7. Collector door seals.

Air leaks can be detected by spraying a soapy water solution onto the seal area. If bubbling of soap occurs, the seal has a leak. Another method is to use your hand to feel for any air movement around the seal. This method requires a calm day, as the wind can make it difficult to detect a leak.

- If any of the above areas leak, remove the parts and replace the seal. Ensure upon reassembly that the parts are tightened sufficiently to prevent air leakage.
- Remove the blank off plates before using the air cart.

Once the pressure test is complete, check the following areas for air leaks:

9. Couplers between air cart and seeding tool.
10. Access doors on divider heads.

Important

It is imperative that no excessive air leaks occur in the air cart tank. Air leaks will lead to product bridging in the tank, thereby causing misses in the field.

Note: When air cart is not in use leave lid latches and inspection doors loose to help maintain resilience of the seals.

Excessive air leak definition:

When assessing air leaks, the use of hot soapy water serves as an effective detection method. The application of this mixture creates an environment for bubble formation, allowing for clear visual indicators of the severity of the leak.

An excessive leak becomes evident when a large bubble forms and bursts almost immediately upon contact with the soapy solution. This rapid collapse suggests that air is escaping at a significant rate, indicating an area that requires repair.

In contrast, a stable, small bubble that forms at a leak represents an acceptable scenario. These bubbles tend to hold their shape without quickly dissipating, implying that the airflow is minimal. Such leaks will not pose any threat to the integrity of the air system.

This distinction between excessive and acceptable leaks can aid maintenance personnel in diagnostics.

Maintenance

Air Delivery System - Continued

Fan

Debris can build up on the fan screen and blades causing reduced output of the fan. The lack of air flow even at higher fan speeds will cause material plugging of the air system.

The build up of material during operation can cause the following:

1. Fan rpm will increase without increasing oil flow to orbit motor.
2. Air cart distribution system plugging from a lack of air flow (Increasing fan rpm has little or no effect).

Fan Screen

- Ensure fan screen is clear of debris. Check periodically through the day.

Fan Impeller

The fan blades may become plugged under high humidity/dusty conditions/high insect counts.

Under severe conditions the fan blades should be inspected daily and cleaned as required.

Under normal conditions the fan should be inspected and cleaned at least once a season.

- Care should be taken in cleaning all fan blades thoroughly to restore the fans peak performance.
- Ensure that the balance clips located on the fan blades are not removed, as this will put the fan out of balance.

Storage

To prevent water entering the air system, cover the fan intake with a plastic bag, whenever the seeder is not in use.

Note: Be sure to remove fan cover prior to starting fan or serious damage could result to the fan.

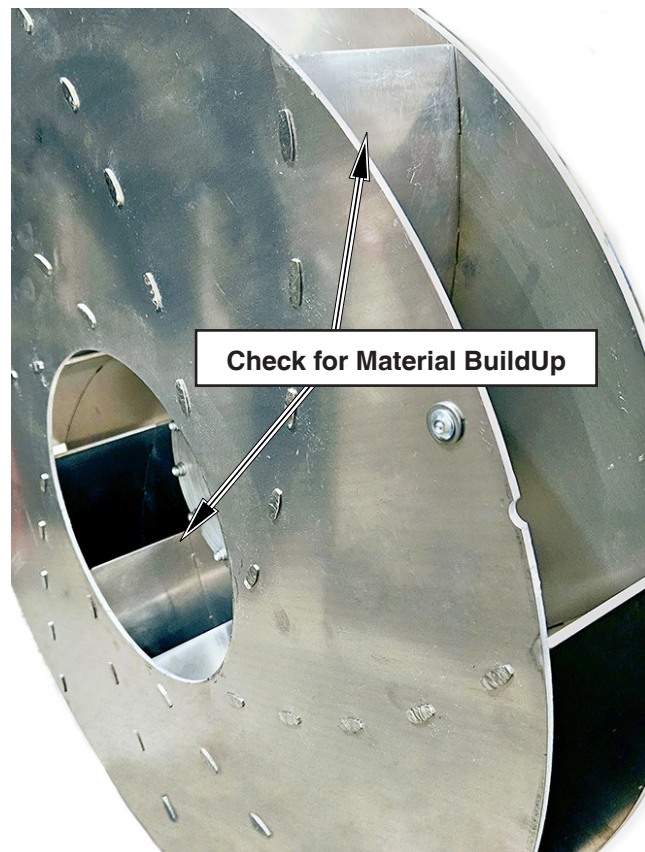

Note: Material build up on the fan blades could cause the fan to be out of balance. The added vibration of the out of balance impeller will reduce the life of the fan components.

Air Delivery System - Continued

Rotor Clearance

- Position rotor 1/8" (3 mm) from inlet.
- Check rotor alignment if tipped at an angle to the inlet adjust inner bearing on blower housing to achieve proper rotor to inlet concentricity.
- If rotor is square to inlet but not concentric to inlet, raise or lower the inlet on the mounting bolts.
- Spin rotor by hand to check for interferences, adjust as required.

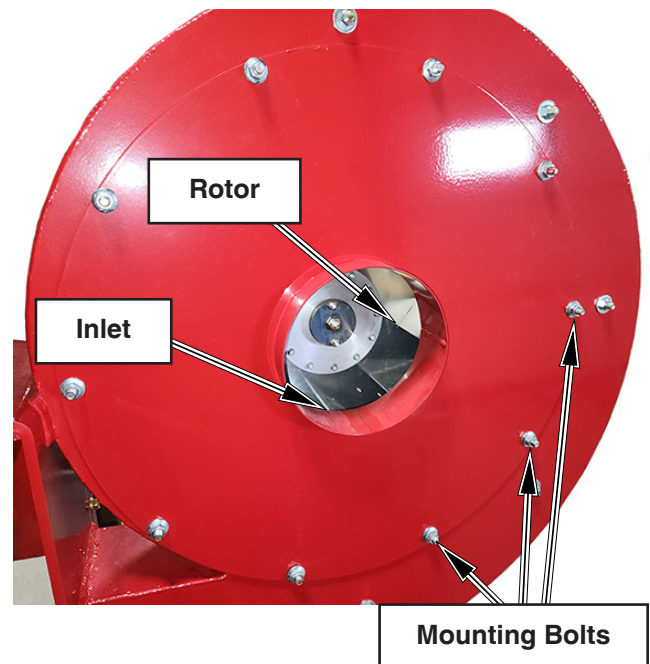

Hoses

Inspect air delivery hoses for wear and replace as required. Check areas where hoses may be exposed to moving parts such as hitch hinge area.

Also, inspect hoses for blockage as rodents/birds may nest in hoses that have not been properly capped during storage.

To optimize the 10 Series Air Cart air system the pressure across the inlets of the quick couplers should be balanced. To achieve this all primary hoses **must be equal in length or use equalizers** to achieve a balanced air system.

Consult with your MORRIS Dealer for assistance on hose lengths and location of equalizers.

Important

ALL primary hoses must be the same length or use equalizers to achieve a balanced air system.

Maintenance

Air Delivery System - Continued

Equalizers

On some seeding tools equalizers are required to balance the air system of the air cart.

- Equalizers are installed on the shorter primary hoses of these seeding tools. Consult with your MORRIS Dealer for assistance on hose lengths and location of equalizers.
- Check equalizers seasonally for wear. If flat section is gone replace equalizer.



Coupler on Seeding Tool



Insert Equalizers on Coupler Seeding Tool side

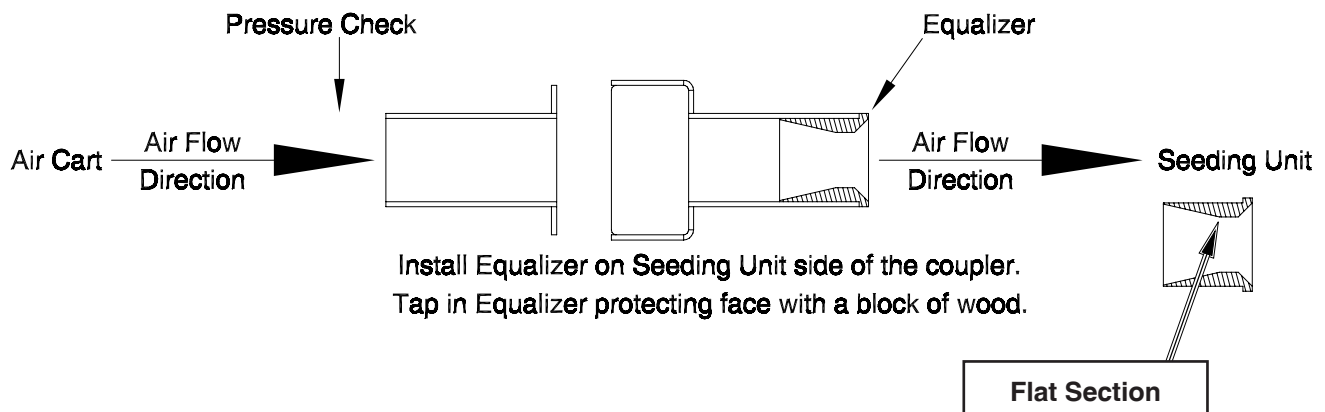

Fan Motor

The motor requires no maintenance itself.

It does, however, require clean oil so the tractor hydraulic filters must be replaced regularly.

Housing Drain

The hydraulic motor has a drain tube with a one way check valve installed between the inner and outer seal. This will prevent oil contamination to the air system in the event the inner seal fails.

If oil is present in this tube, it is a sign that the inner seal is failing or has failed. Replace seal immediately.

Repair/Replacement

- Remove orbit motor from the fan.

Note: The shaft should never be hammered on or forced in as this will result in motor damage upon startup.

- Remove the snap ring.
- Clean away paint then remove front cover.
- Push out the old shaft seal and press in the new one.

Note: The bearings should never be removed from the shaft as they are pretensioned to the shaft with the motor spinning.

- Replace the O-ring.
- Both the O-ring and shaft seal should be greased with “clean” grease.
- Care must be taken when the front cover is installed so the shaft seal is not damaged.
- Reinstall the snap ring.
- Fill the motor case with “clean” oil before running.

Note: Any time a motor is replaced the case must be filled with oil before it is started, if not, a bearing failure could occur.

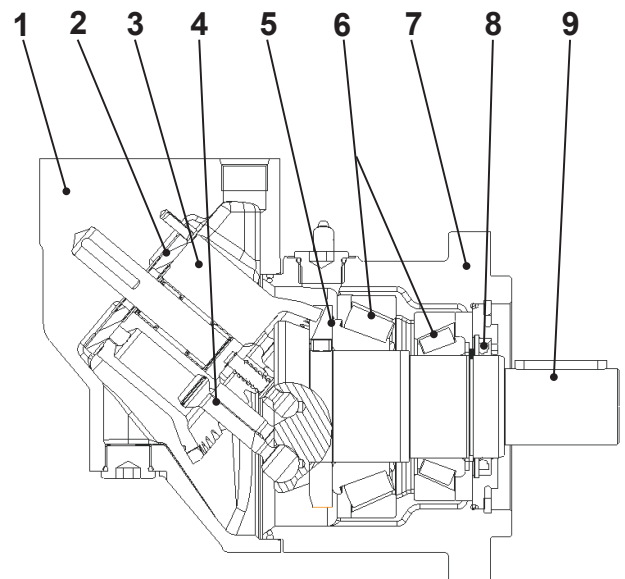
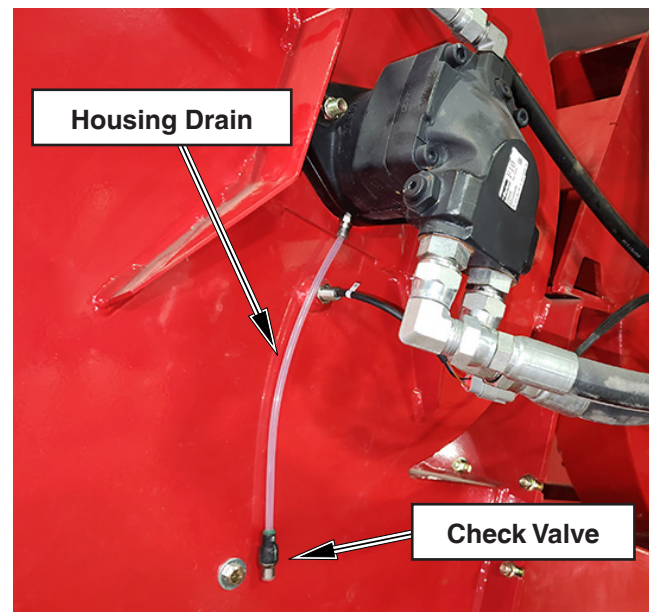

F10 cross section

1. Barrel housing
2. Valve plate
3. Cylinder barrel
4. Piston with piston ring
5. Timing gear
6. Tapered roller bearing
7. Bearing housing
8. Shaft seal
9. Output/input shaft

Maintenance

Hydraulics

Refer to Section 1 regarding hydraulic safety. In addition:

- Inspect hydraulic system for leaks, damaged hoses and loose fittings.
- Damaged hoses and hydraulic tubing can only be repaired by replacement. **DO NOT ATTEMPT REPAIRS WITH TAPE OR CEMENTS.** High pressure will burst such repairs and cause system failure and possible injury.
- Leaking cylinders - install a new seal kit.
- Fittings - use liquid Teflon on all NPT hydraulic joints. **Do not use liquid Teflon or Teflon tape on JIC or ORB ends.**
- Hydraulic Hose Connections - when connecting the hoses to the cylinders, tubing, etc. always use one wrench to keep the hose from twisting and another wrench to tighten the union. Excessive twisting will shorten hose life.
- Keep fittings and couplers clean.
- Check the Tractor Manual for proper filter replacement schedule.



Contact your nearest Dealer for genuine repair parts. Dealers carry ample stocks and are backed by the manufacturer and regional associations.

Caution

Dirt in the hydraulic system could damage O-rings, causing leakage, pressure loss and total system failure.

Note: Extreme care must be taken to maintain a clean hydraulic system. Use only new hydraulic fluid when filling reservoir.

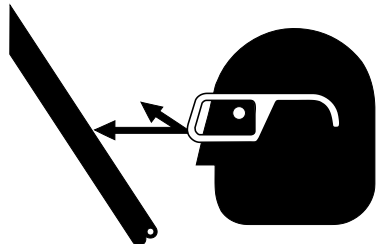

Warning

HIGH-PRESSURE FLUID HAZARD

To prevent serious injury or death:

- **Relieve pressure on hydraulic system before servicing or disconnecting hoses.**
- **Wear proper hand and eye protection when searching for leaks. Use wood or cardboard instead of hands.**
- **Keep all components in good repair.**

Wheel Bearings

- Shut tractor off and remove key.
- Block wheel on tractor.
- Raise the air cart wheels enough to clear the surface.
- Securely block air cart frame.
- Remove wheel from hub.
- Remove the dust cap, cotter pin, and the slotted nut and washer.
- Be careful when pulling the hub off as not to drop the outer bearing.
- Clean spindle and bearing components with solvent.
- Inspect for wear on bearings, spindle and cups. Replace parts as required.
- Do not reuse old seals. Use only new seals when assembling.
- Pack inner section of hub with bearing grease.
- Be sure bearings and cups are dry and clean.
- Work grease into the bearing rollers, until each part of the bearings are completely full of grease.
- Install inner bearing and cup first, then press new seals in place.
- Place hub on spindle.
- Install outer bearing, washer and slotted nut.
- Tighten nut while turning the wheel until a slight drag is felt.
- Back nut off one slot and install a cotter pin. Bend cotter pin up around nut.
- Pack grease inside the dust cap and tap into position.

Important

Check wheel bearings for play every
5,000 acres (2,000 hectares)
or yearly, whichever occurs first.
Tighten as required.

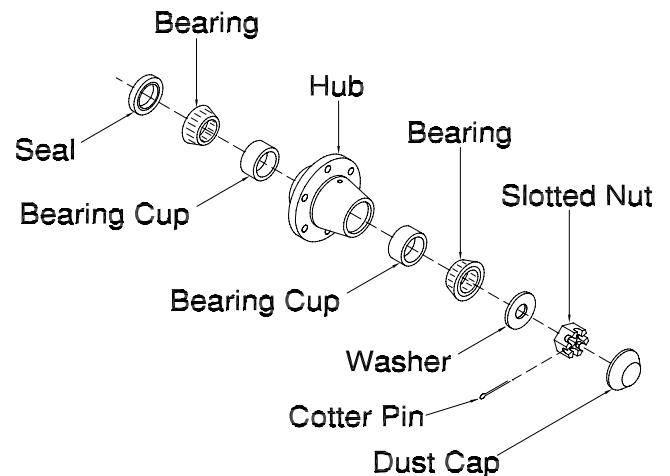

Maintenance

Quad Steer

- Periodically check the 1 bolts, flatwashers and locknuts attaching the axle and pivot assembly. Torque **Grade 5** bolts to 590 lb-ft.
- Dry torque the M22 nuts to **500 lb-ft (678 Nm)** following the sequence in the illustration. A 4:1 torque multiplier is recommended for ease of operation. **(Do not use lubricant)**

Important

Retorque wheel nuts to 500 lb-ft (678 Nm) after first fifteen minutes of operation and every 1/2 hour for the next 2 hours, after 5 hours, after 25 hours and after 50 hours. Check periodically afterwards.

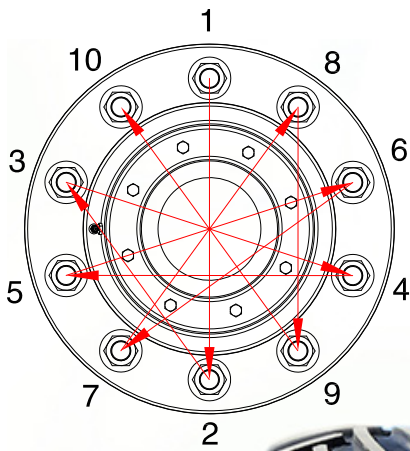

Dual Wheels

660 Cart - Rear Duals

1440 Cart - Front Duals

The illustration below shows the components of the hub adapter, see following 3 pages for details on removing and installing tires.

⚠ Caution

Tire replacement should be done by trained personnel using the proper equipment. Tires are heavy and could fall as soon as the wheel nuts are removed.

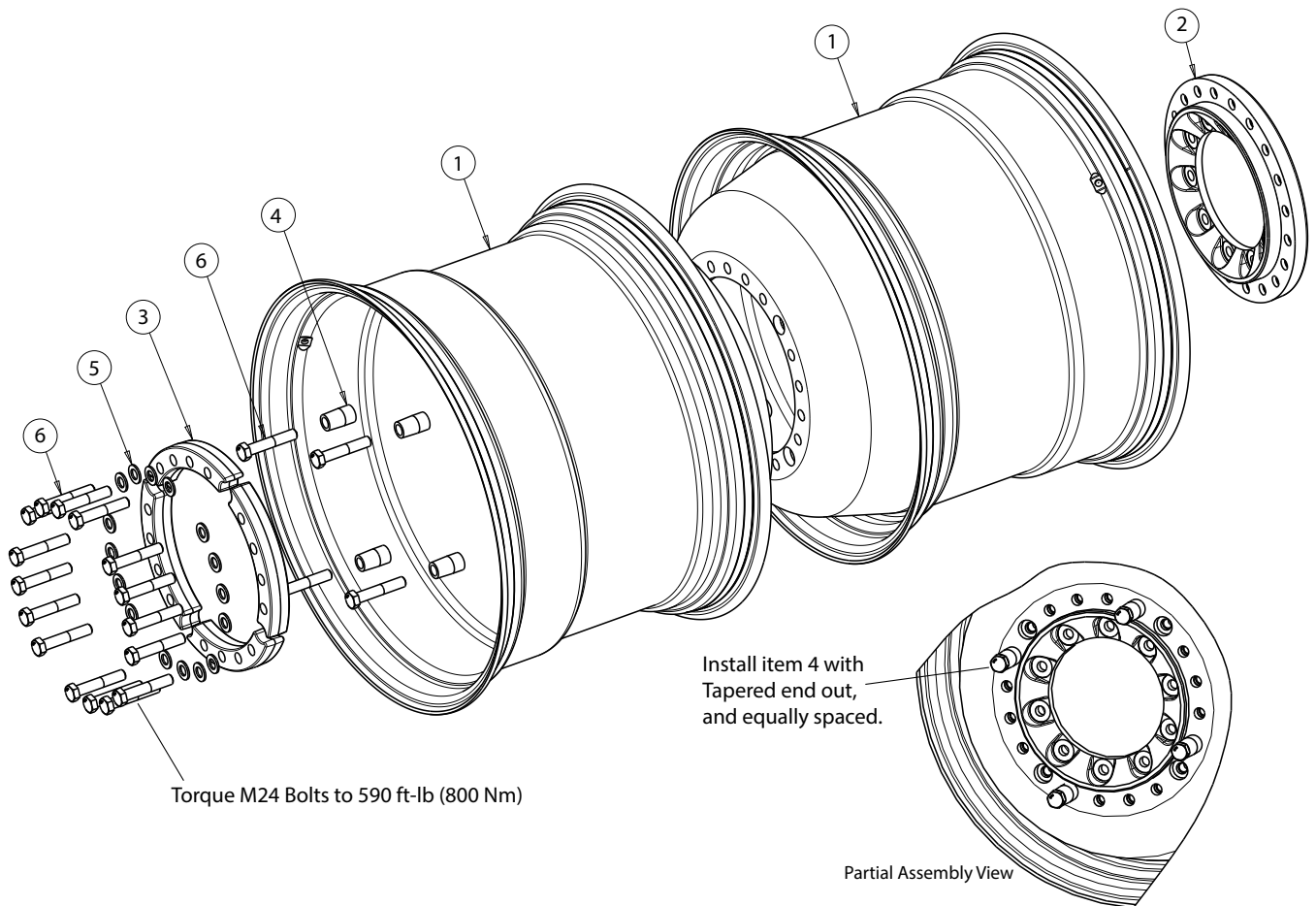

Item	Part No.	Description	Qty
1	*****	Dual Rim - (20 bolts)	2
2	N71475	Dual Wheel Hub Adapter	1
3	N71473	Hub Adapter Spacer Segment	4
4	N71469	Hub Adapter Alignment Bushing	4
5	N71476	Washer M24 Hardened	16
6	N71471	Hex Bolt - M24-3.00 x 130 mm Lg Gr10.9.....	20

Maintenance

Dual Wheels - Continued

660 Cart - Rear Duals - Continued

1440 Cart - Front Duals - Continued

Removal and Installation

- Empty all product from air cart tanks.
- Park the air cart on a flat and level area of hard ground.
- Shut tractor off and remove key.
- Block all of the air cart tires to ensure the unit does not move.
- Loosen the wheel nuts while the air cart is still on the ground.
- Raise the air cart tires enough to clear the surface.
- Securely block air cart frame.
- Position dual dolly around wheel to be removed and block to prevent movement of the dolly
- Remove wheel from hub.

Outer Dual Tires:

Outer Dual removal:

- Remove one clamping segment at a time, leaving the bolts with the alignment bushing in place located in the large holes in the rim.
- The alignment bushings will ensure the inner dual is held on when the outer dual is removed.
- With all four clamping segments removed the outer dual can slide off the alignment bushings.

Outer Dual installation:

- Position the larger holes in the outer dual over the alignment bushings and slide into position.
- Reinstall clamping segments with the hardened washers and M24 bolts.
- Torque the M24 Bolts to 590 lb-ft (800 Nm) See next page for torque sequence details.

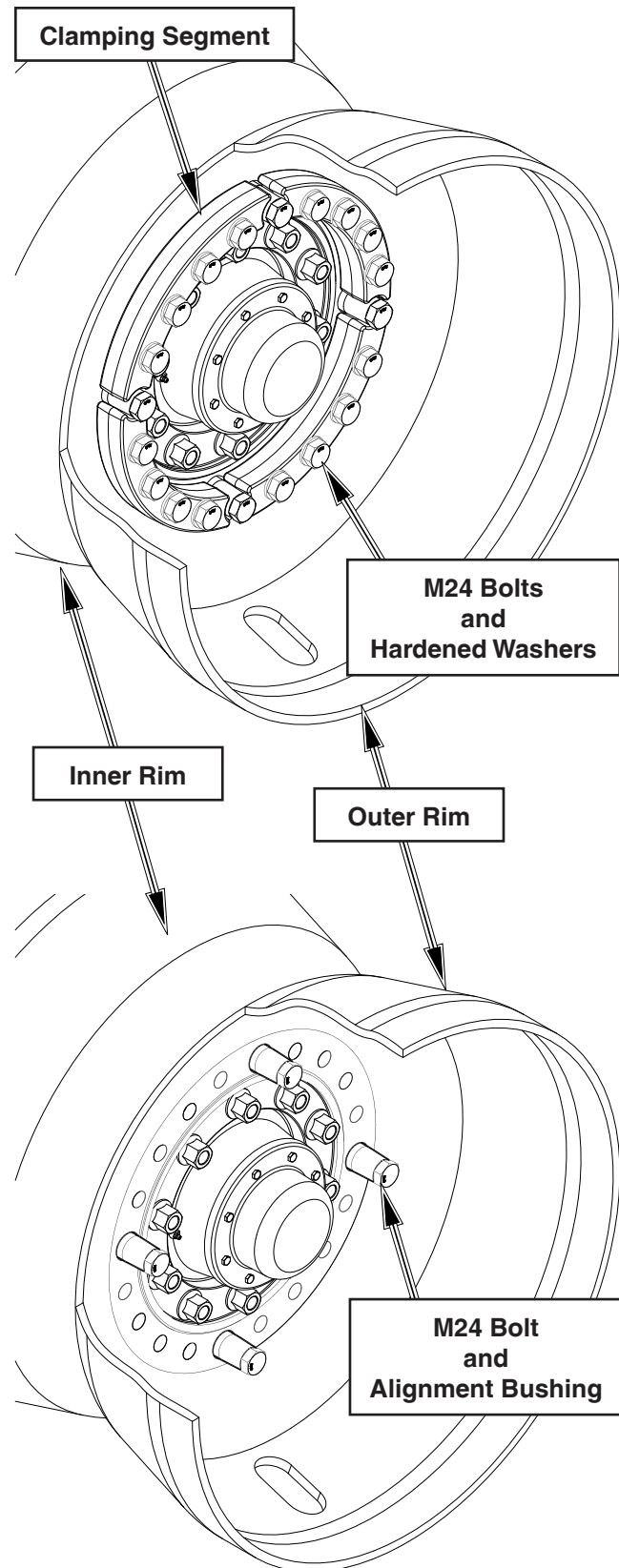

Caution

Tire replacement should be done by trained personnel using the proper equipment. Tires are heavy and could fall as soon as the wheel nuts are removed.

Dual Wheels - Continued

660 Cart - Rear Duals - Continued

1440 Cart - Front Duals - Continued

Inner Dual Tires:

Inner Dual removal:

- Remove outer dual as outlined on previous page.
- Remove the M24 bolts and alignment bushings.
- Remove inner dual from dual wheel adapter.

Inner Dual installation:

Install the new dual using the following process:

- Position the inner dual on the lip of the adapter.
- Install the alignment bushings (tapered end out) with M24 bolts in the small holes clockwise of large holes.
- Install the outer dual tire as outlined on previous page.
- Position the larger holes in the outer dual over the alignment bushings and slide into position.
- Reinstall clamping segments with the hardened washers and M24 bolts.
- Torque the M24 Bolts to 590 lb-ft (800 Nm) See next page for torque sequence details.

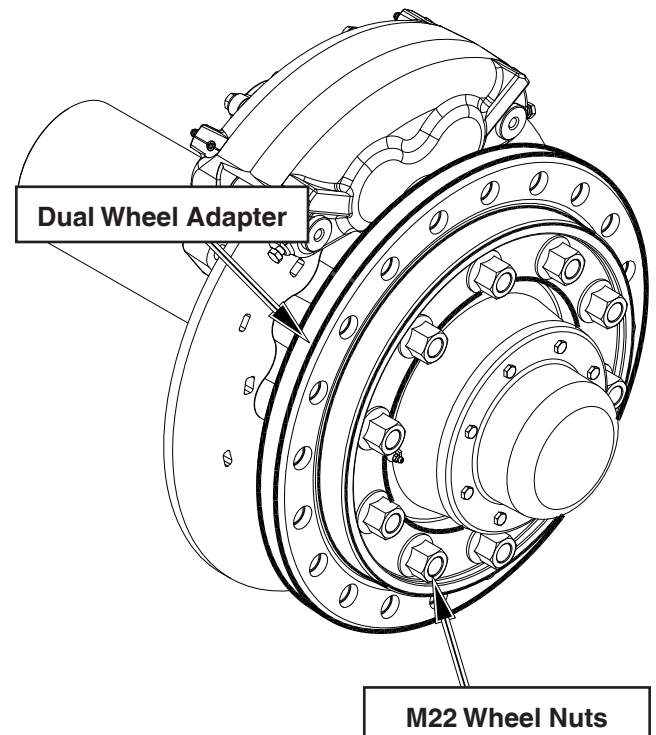
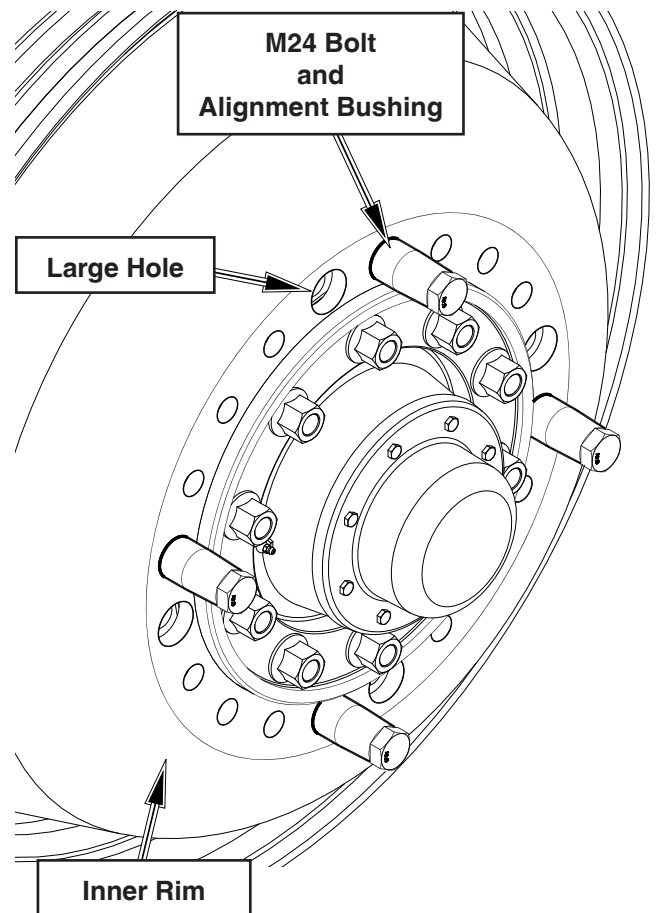

Caution

Tire replacement should be done by trained personnel using the proper equipment. Tires are heavy and could fall as soon as the wheel nuts are removed.

Maintenance

Dual Wheels - Continued

660 Cart - Rear Duals - Continued

1440 Cart - Front Duals - Continued

10 Bolt Torque Pattern

- Dry torque the M22 nuts to **500 lb-ft (678 Nm)** following the sequence in the illustration. A 4:1 torque multiplier is recommended for ease of operation. **(Do not use lubricant)**

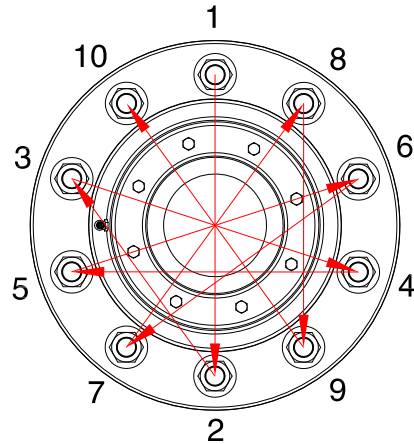

Important

Retorque wheel nuts to 500 lb-ft (678 Nm) after first fifteen minutes of operation and every 1/2 hour for the next 2 hours, after 5 hours, after 25 hours and after 50 hours. Check periodically afterwards.

20 Bolt Torque Pattern

- Dry torque the M24 Bolts to **590 lb-ft (800 Nm)** following the sequence in the illustration. A 4:1 torque multiplier is recommended for ease of operation. **(Do not use lubricant)**

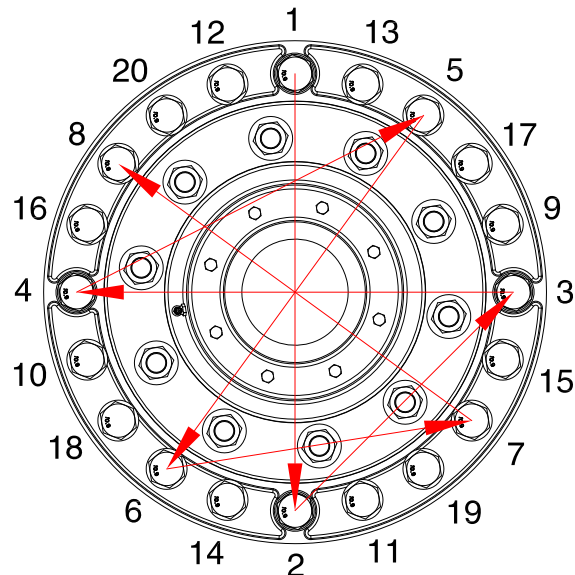

Important

Retorque wheel nuts to 590 lb-ft (800 Nm) after first fifteen minutes of operation and every 1/2 hour for the next 2 hours, after 5 hours, after 25 hours and after 50 hours. Check periodically afterwards.

Dual Wheels - Continued

820, 1050 and 1440 Cart - Rear Duals

The illustration below shows the components of the dual hub assembly, see following 3 pages for details on removing and installing tires.

⚠ Caution

Tire replacement should be done by trained personnel using the proper equipment. Tires are heavy and could fall as soon as the wheel nuts are removed.

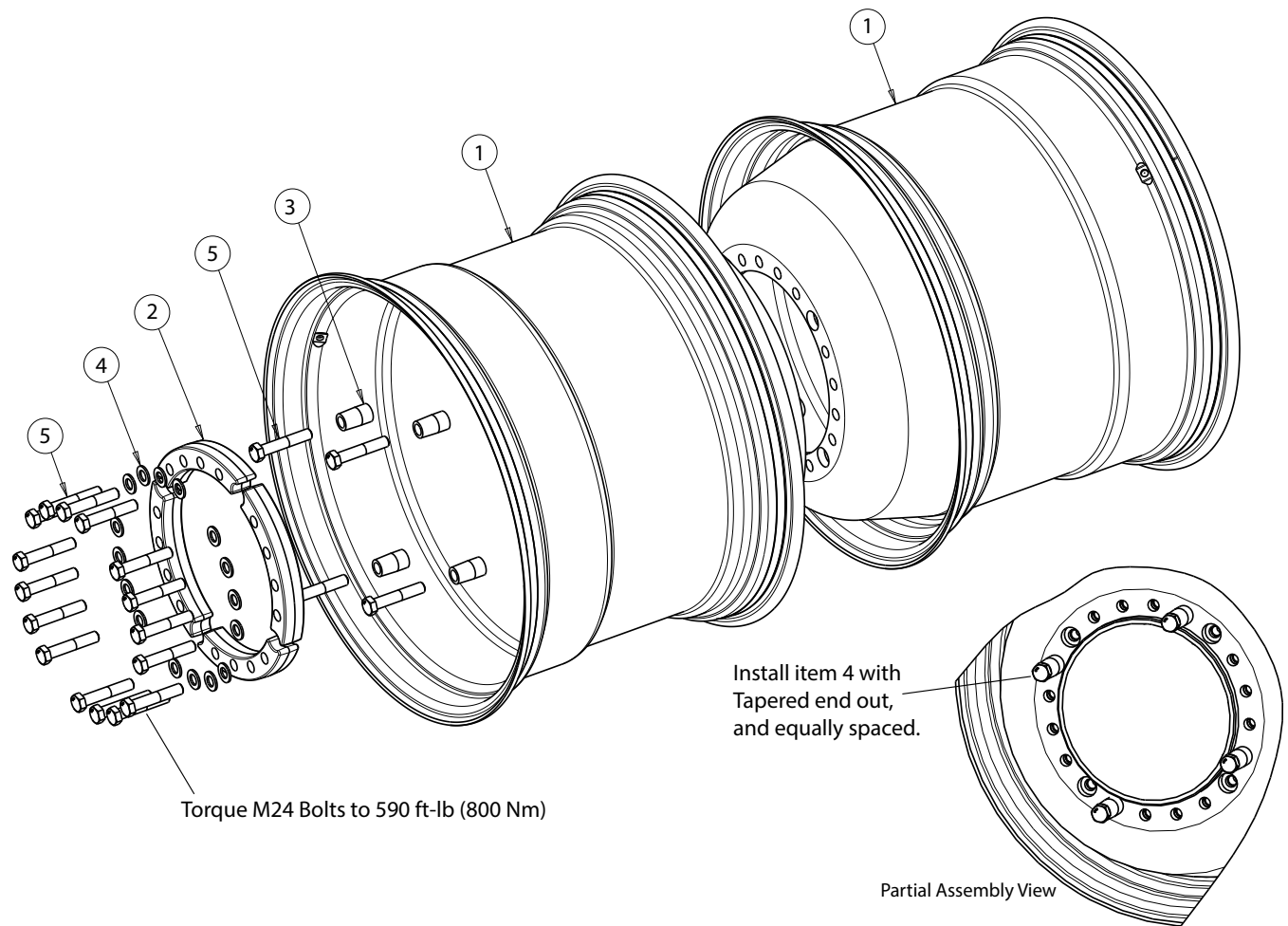

Item	Part No.	Description	Qty
1	*****	Dual Rim - 42 x DW27B - (20 bolts).....	2
2	N71473	Hub Adapter Spacer Segment	4
3	N71469	Hub Adapter Alignment Bushing	4
4	N71476	Washer M24 Hardened	16
5	N71471	Hex Bolt - M24-3.00 x 130 mm Lg Gr10.9.....	20

Maintenance

Dual Wheels - Continued

820, 1050 and 1440 - 42 Rims - Continued

Removal and Installation

- Empty all product from air cart tanks.
- Park the air cart on a flat and level area of hard ground.
- Shut tractor off and remove key.
- Block all of the air cart tires to ensure the unit does not move.
- Loosen the wheel nuts while the air cart is still on the ground.
- Raise the air cart tires enough to clear the surface.
- Securely block air cart frame.
- Position dual dolly around wheel to be removed and block to prevent movement of the dolly
- Remove wheel from hub.

Outer Dual Tires:

Outer Dual removal:

- Remove one clamping segment at a time, leaving the bolts with the alignment bushing in place located in the large holes in the rim.
- The alignment bushings will ensure the inner dual is held on when the outer dual is removed.
- With all four clamping segments removed the outer dual can slide off the alignment bushings.

Outer Dual installation:

- Position the larger holes in the outer dual over the alignment bushings and slide into position.
- Reinstall clamping segments with the hardened washers and M24 bolts.
- Torque the M24 Bolts to 590 lb-ft (800 Nm) See next page for torque sequence details.

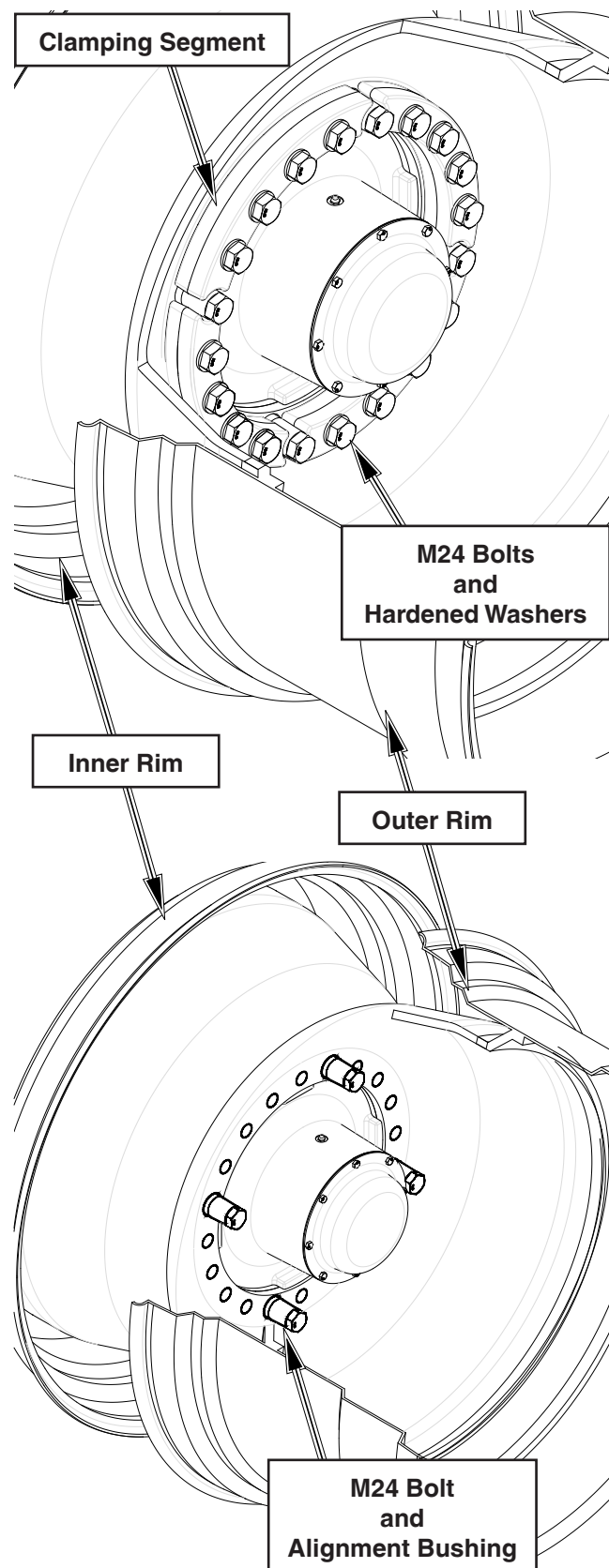

Caution

Tire replacement should be done by trained personnel using the proper equipment. Tires are heavy and could fall as soon as the wheel nuts are removed.

Dual Wheels - Continued

820, 1050 and 1440 - 42 Rims - Continued

Inner Dual Tires:

Inner Dual removal:

- Remove outer dual as outlined on previous page.
- Remove the M24 bolts and alignment bushings.
- Remove inner dual from dual wheel adapter.

Inner Dual installation:

Install the new dual using the following process:

- Position the inner dual on the lip of the Hub.
- Install the alignment bushings (tapered end out) with M24 bolts in the small holes clockwise of large holes.
- Install the outer dual tire as outlined on previous page.
- Position the larger holes in the outer dual over the alignment bushings and slide into position.
- Reinstall clamping segments with the hardened washers and M24 bolts.
- Torque the M24 Bolts to 590 lb-ft (800 Nm) See next page for torque sequence details.

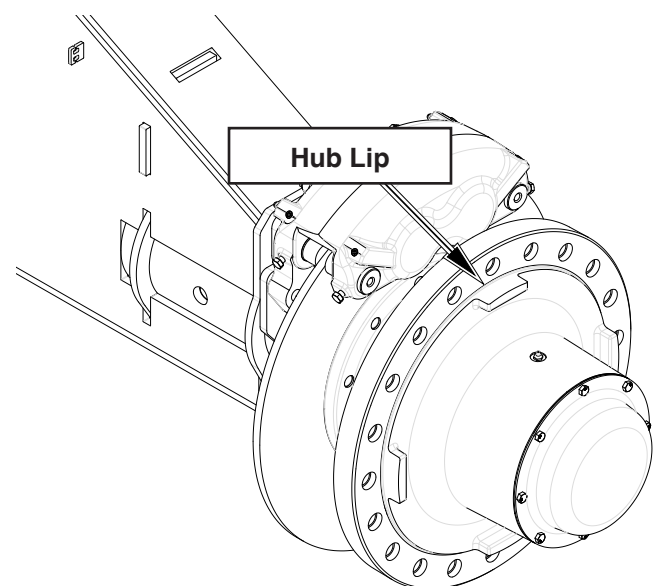
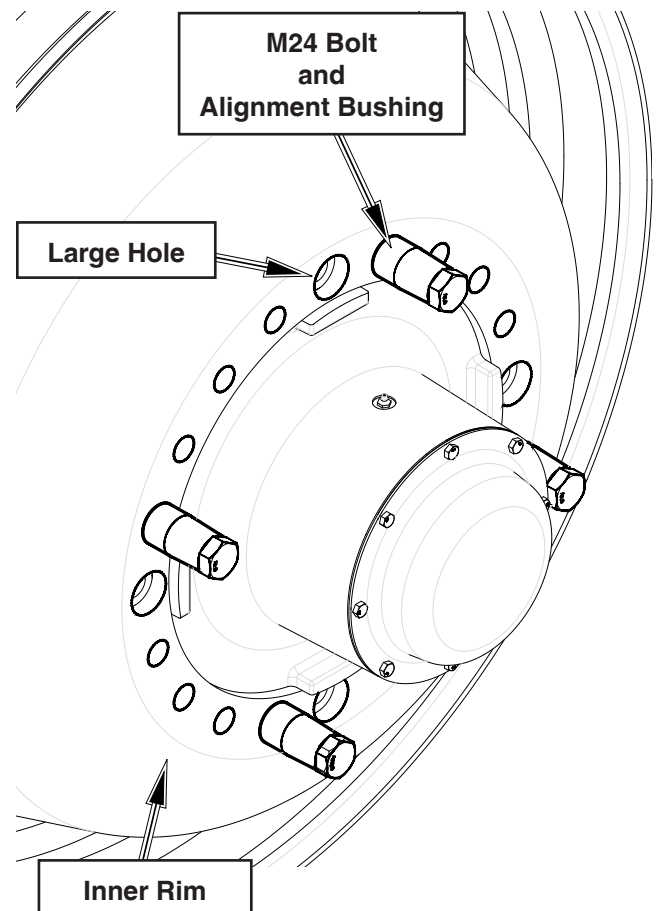

Caution

Tire replacement should be done by trained personnel using the proper equipment. Tires are heavy and could fall as soon as the wheel nuts are removed.

Maintenance

Dual Wheels - Continued

820, 1050 and 1440 - 42 Rims - Continued

20 Bolt Torque Pattern

- Dry torque the M24 Bolts to **590 lb-ft (800 Nm)** following the sequence in the illustration. A 4:1 torque multiplier is recommended for ease of operation. **(Do not use lubricant)**

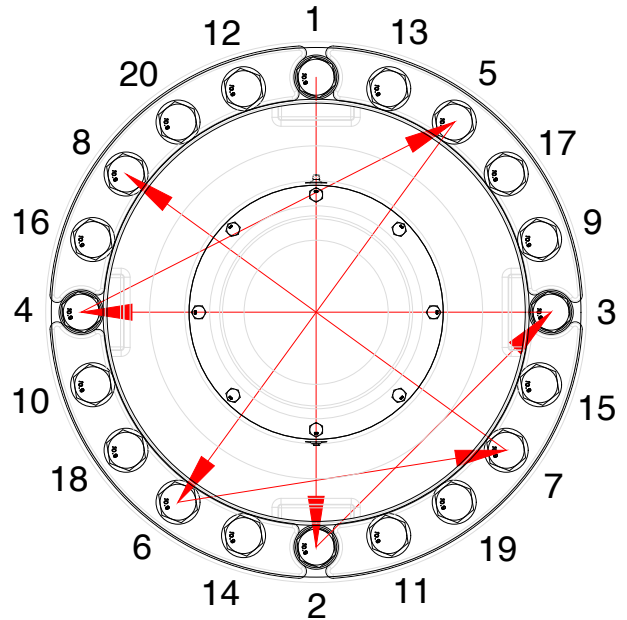

Important

Retorque wheel nuts to 590 lb-ft (800 Nm) after first fifteen minutes of operation and every 1/2 hour for the next 2 hours, after 5 hours, after 25 hours and after 50 hours. Check periodically afterwards.

Rear Axle Extensions

Torque Rear Axle Hardware

- **Lubricate** bolt threads with thread lubricant.
- **Wet** torque the 1" nuts to **480 lb-ft (651 Nm)** following the sequence in the illustration. A 4:1 torque multiplier is recommended for ease of operation. **(Lubricant bolts with thread lubricant)**

IMPORTANT: Retorque the mounting bolts after the first 10 hours of operation, and 50 hours and yearly thereafter.

Torque Pattern

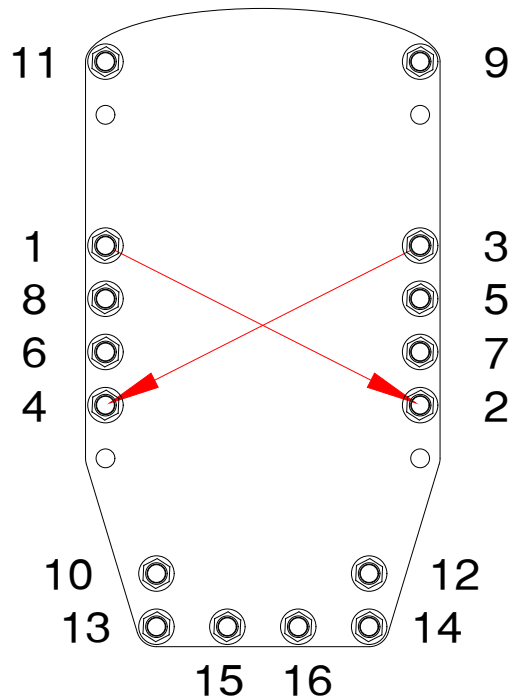

Seed Plate Adjustment

Ensure that when the adjustment handle is in the Fine position notch that the seed plates are tight up against the metering wheels spacers.

If this does not occur adjust the adjustment plate by loosening the bolts that attach the plate to the metering body and slide the plate accordingly.

This adjustment must be done without product in the tank or with the slide gates closed and the metering body cleaned out.

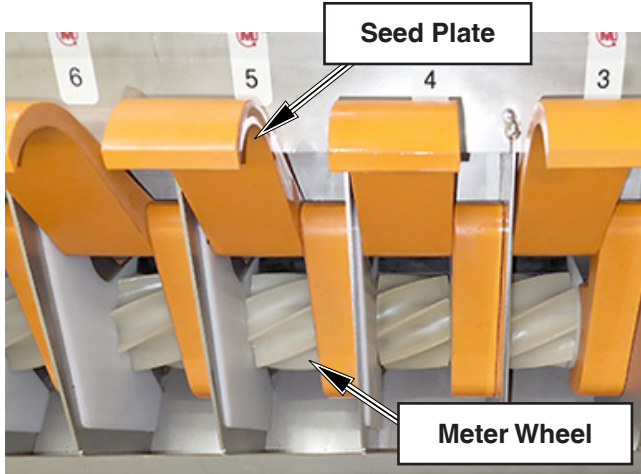

Ensure Metering is Free of Debris

Important

Do not try and close the seed plates with the product in the metering body as damage can occur from the product being squeezed between the wheels and seed plates.

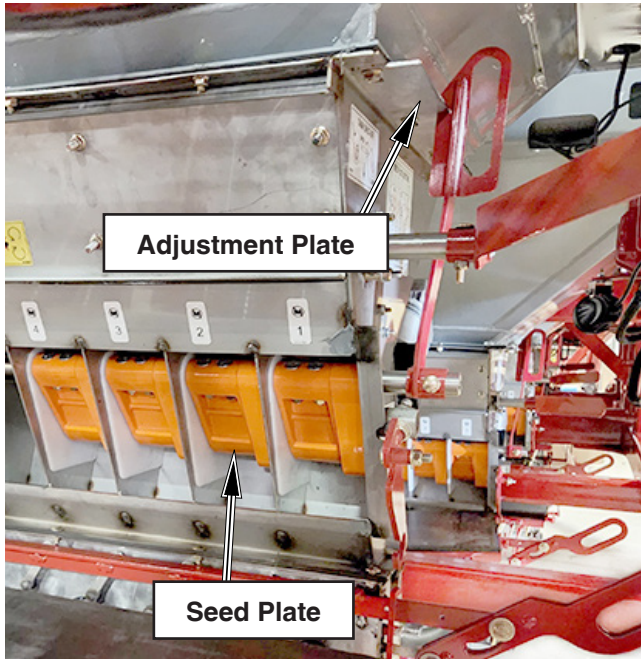

Maintenance

Gearbox Removal / Installation

To remove the gearbox follow the steps below:

1. Open seed plate inspection door and fully rotate seed plates away from the meter wheels.
2. Remove motor from motor base.
3. Unbolt gearbox from motor base mount.
4. Simultaneously rotate the gearbox assembly down and the gearbox covers up to dislodge the gearbox.
5. Continue this motion until the gearbox assembly falls freely into the meter body.
6. Swing the gearbox cover out of the way completely.
7. Remove the gearbox/seed wheel assembly.

To reassemble reverse the above steps in addition to steps 8, 9 and 10:

8. Ensure all mounting surfaces and meter components are clean of debris.
9. Ensure motor base is concentric with gearbox input shaft.
10. Tighten motor down to **60 in-lbs** in below pattern.

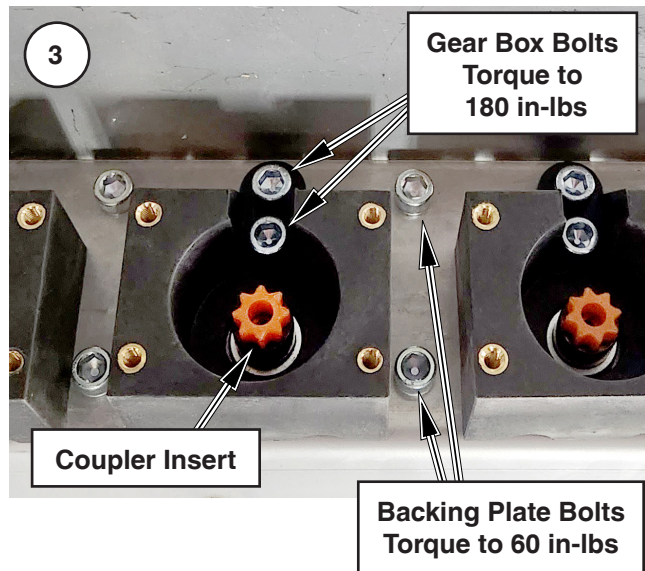
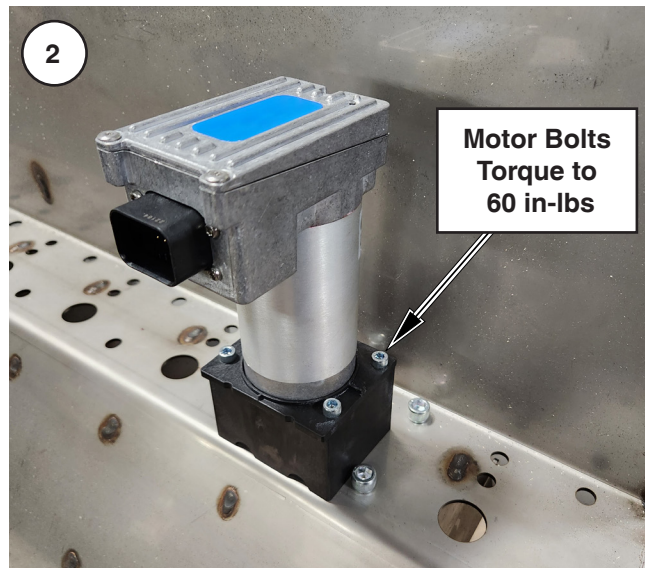
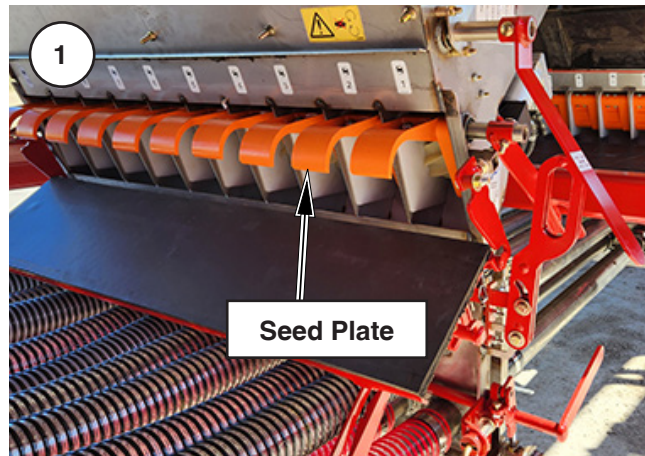
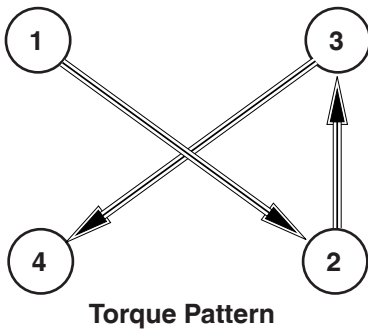

Important

Do not contact electronic or electrical components and connectors with high pressure wash.

Gearbox Removal / Installation - Continued

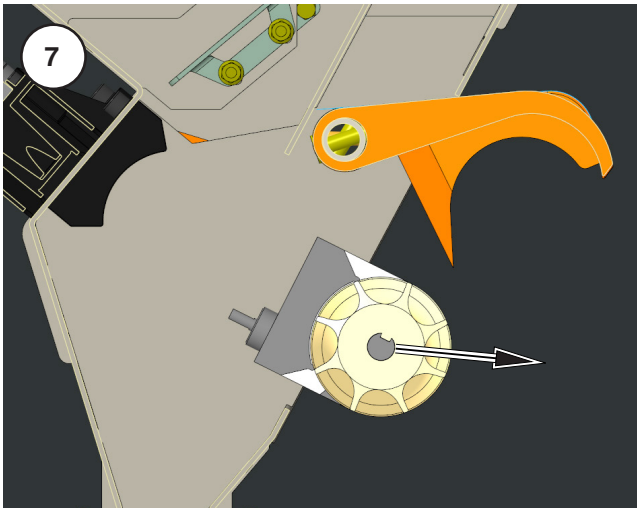
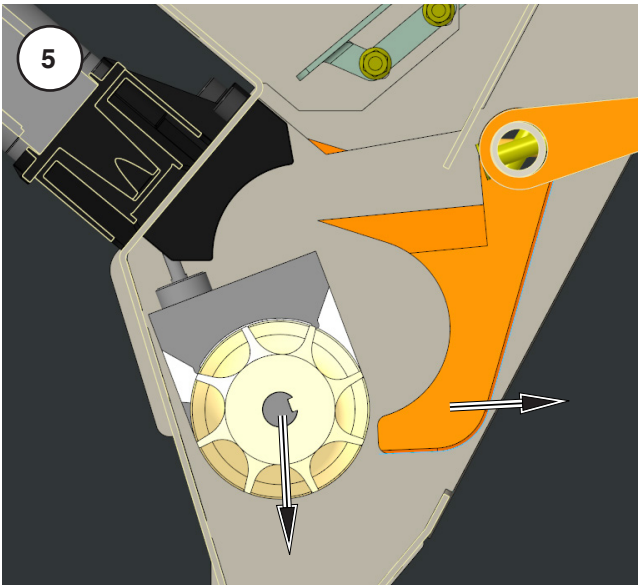
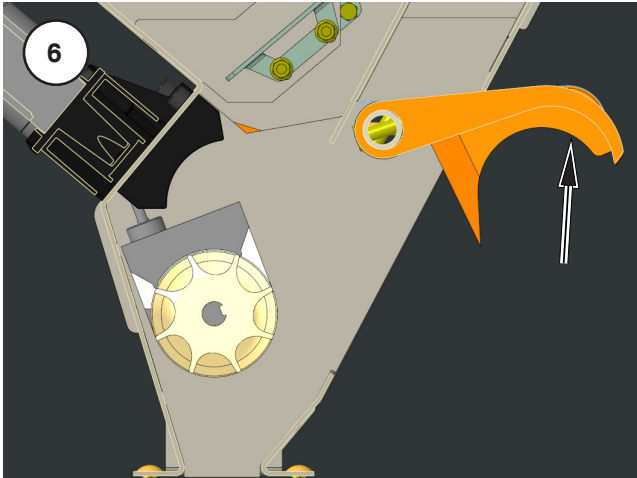
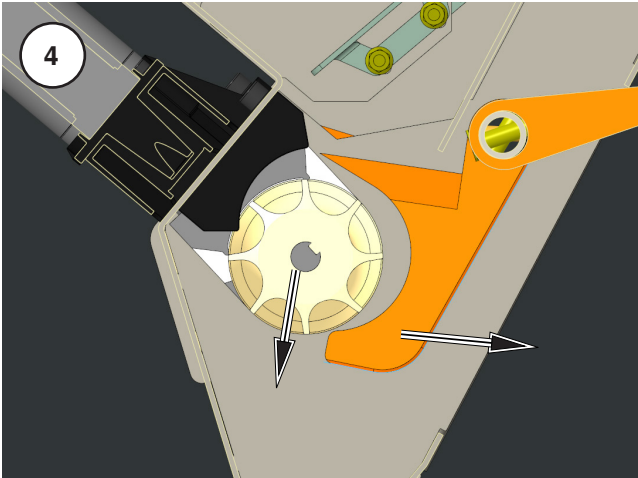

Bolt Torque Specifications:

Gear Box Bolts - torque to 180 in-lbs

Motor Bolts - torque to 60 in-lbs

Backing Plates - torque to 60 in-lbs

Maintenance

Auxiliary Power Unit (APU)

Battery

- Remove batteries at the end of the season.

Note: Disconnect negative (-) battery terminals first.

- Charge both batteries fully.
- Store indoors and off the ground.

Note: Check the condition of each battery and charge fully before using batteries that have not been used in more than three months.

Battery Replacement

The APU uses two 12V group 24F batteries with a 700CCA - 875CA with 120 minimum RC (reserve capacity) rating.

Replace both batteries at the same time, use the exact same battery for both. Mismatched batteries will cause undercharging on one and overcharging on the other battery and will result in reduced battery life.

- Install batteries terminal side next to APU box as illustrated.
- Ensure terminals and cable ends are clean. Use a terminal brush and terminal cleaner to neutralize and remove any corrosion.
- Use the battery-link cable to connect battery 1 negative post to battery 2 positive post.
- Connect the alternator positive cable to battery 1 positive post, and connect the alternator negative cable to battery 2 negative post.
- Apply a coat of corrosion sealant to the terminals and cable ends.
- Slide batteries under step. Install the straps around the batteries and cinch them to secure the batteries against APU box.

Fuses and Relay

The Auxiliary Power Unit (APU) uses MEGA fuses.

Replace blown fuses with the same value.

Note: Do not use higher amp fuses. Damage to the wiring harness or connectors may occur.

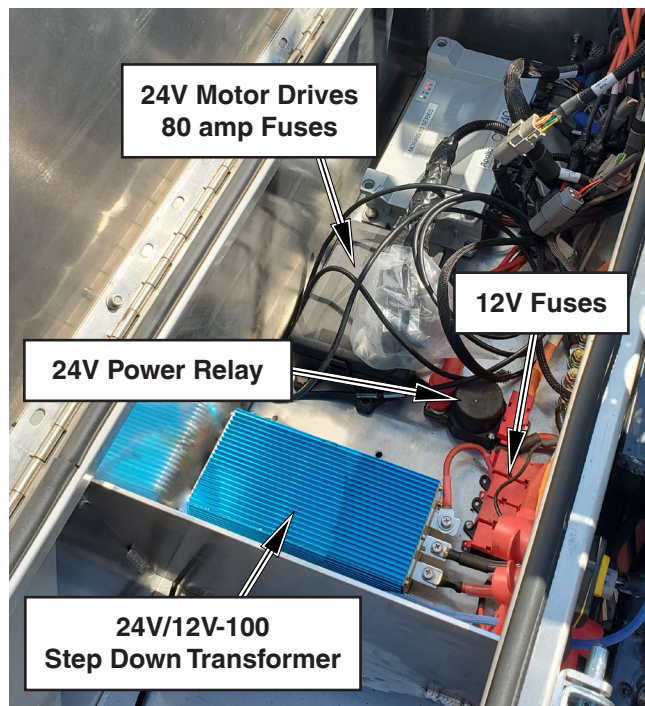
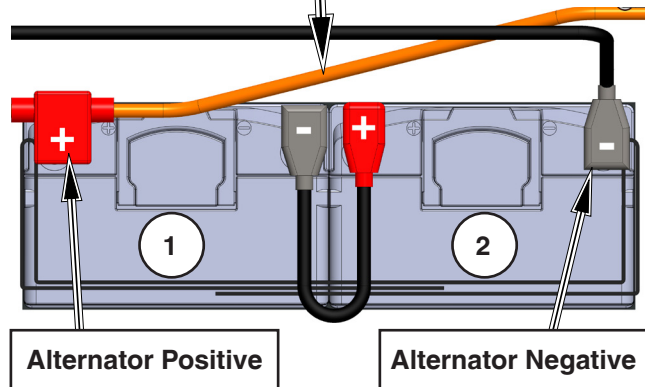
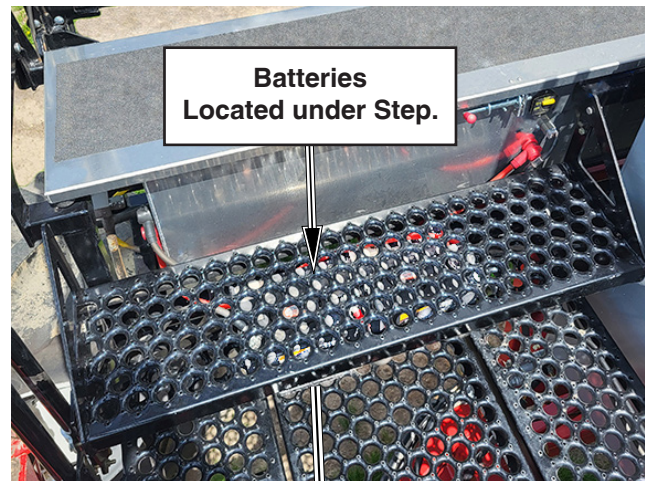

Important:

**DO NOT Run Alternator with Power turned OFF.
Damage to the Alternator may occur.**

Auxiliary Power Unit (APU) - Continued

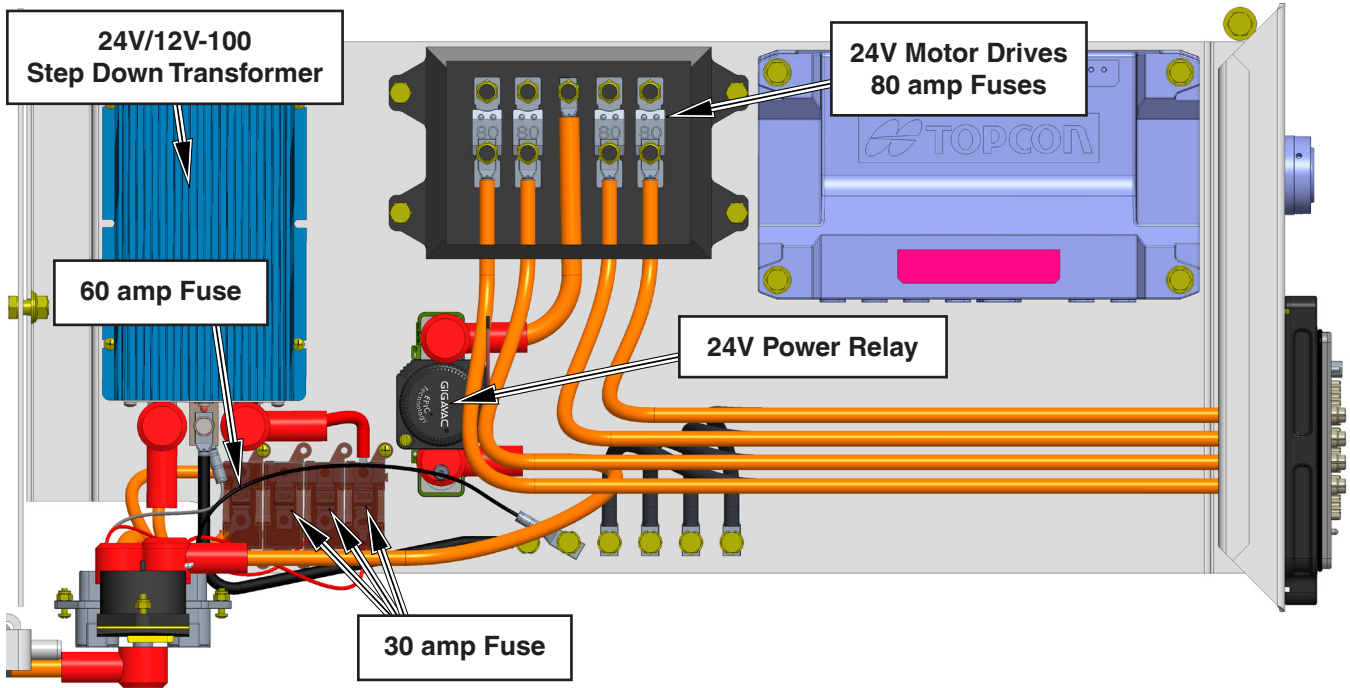

Important

Do not contact electronic or electrical components and connectors with high pressure wash.



Protecting the electrical/electronic systems during charging or welding

To protect the air cart electronics from currents induced during arc welding follow these steps.

1. Connect the ground clamp as close to the weld area as possible.
2. Unplug all connectors at the Auxiliary Power Unit (APU).
3. Unplug all connectors to the brake control unit.
4. Unplug each meter motor harness from the main air cart harness. It is not necessary to unplug each individual motor.

Maintenance

Brakes

Periodic Inspection should be made of the electrical connector, wiring, brake lines and hose for the entire brake system to insure there are no abraded or bare wires, damaged steel lines, or cracked and damaged hoses. During inspection assure there are no loose or “hanging” lines or wire that might drag or catch on objects/debris while being towed.

Fill Reservoir

There are two filler caps on the reservoir, either may be used for filling and checking fluid level as they both enter a common reservoir. Use caution when removing a filler cap to prevent the admission of dirt and/or contaminants into the fluid reservoir.

Check the fluid level in the reservoir. The fluid level must be maintained within 3/8 to 1/2 inch below the filler opening. If brake fluid is needed add only **NEW, CLEAN, DOT III BRAKE FLUID**.

Never reuse brake fluid that has been salvaged or removed from another system. Contaminated or dirty brake fluid may cause damage to the system resulting in system failure.

Bleeding Brakes

It is essential to remove all air from the brakes and brake-lines prior to operation of the Air Cart. Operate unit with tractor brakes or manual override on Controller. Each Caliper has two (2) bleeder screws, each one should be bleed until fluid is free of air bubbles.

While performing the bleeding process monitor the fluid level in the reservoir so that more air is not pumped into the brake lines because of low fluid level.

To prevent spilling brake fluid on the ground one end of a length of plastic tubing should be placed over the end of the bleeder screw and the other end should be placed into a container so that the fluid flow can be monitored for bubbles.

Single Caliper Brake Bleeding

Starting with the right brake open bleeder screw #1 and allow it to remain open until seeing brake fluid free of air bubbles coming out of the bleeder screw. Close the bleeder screw and move to the second bleeder screw repeating process. Repeat process for left brake.

Note: Final stage of brake bleeding must be performed with tractor running to achieve full voltage/amps at BrakeRite pump. Unit will not generate maximum pressure otherwise.

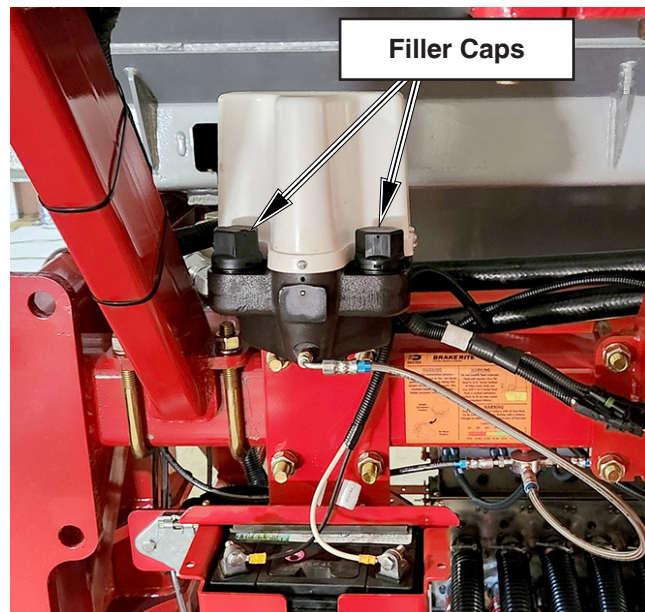

Important:

Use only DOT III brake fluid.

Maintain fluid level within 3/8 to 1/2 inch below the filler opening.

Use caution when removing the filler cap to prevent contaminants entering into the fluid reservoir.

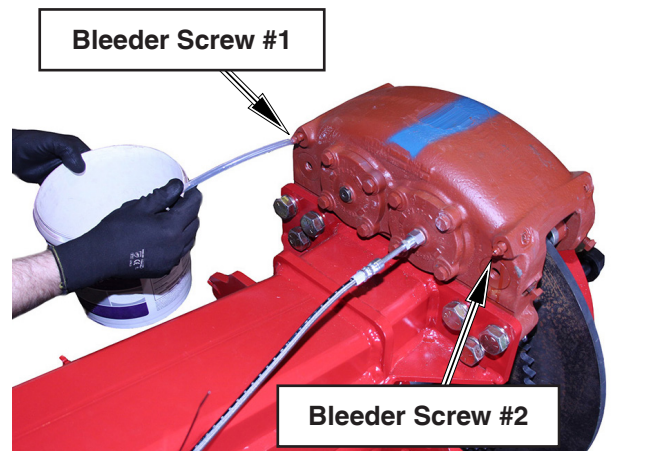

Single Caliper Brake

Brakes - Continued

Bleeding Brakes - Continued

Dual Caliper Brake Bleeding

Each Caliper has two (2) bleeder screws, each one should be bleed until fluid is free of air bubbles.

Start with the caliper #2 on the right brake, open bleeder screw #1 (the farthest one from the main line) and allow it to remain open until seeing brake fluid free of air bubbles coming out of the bleeder screw. Close the bleeder screw and move to the second bleeder screw repeating process.

Repeat process for caliper #1 starting with bleeder screw #3 and finishing with bleeder screw #4 (closest screw to main line).

Repeat process for the left brake calipers.

Note: Final stage of brake bleeding must be performed with tractor running to achieve full voltage/amps at BrakeRite pump. Unit will not generate maximum pressure otherwise.

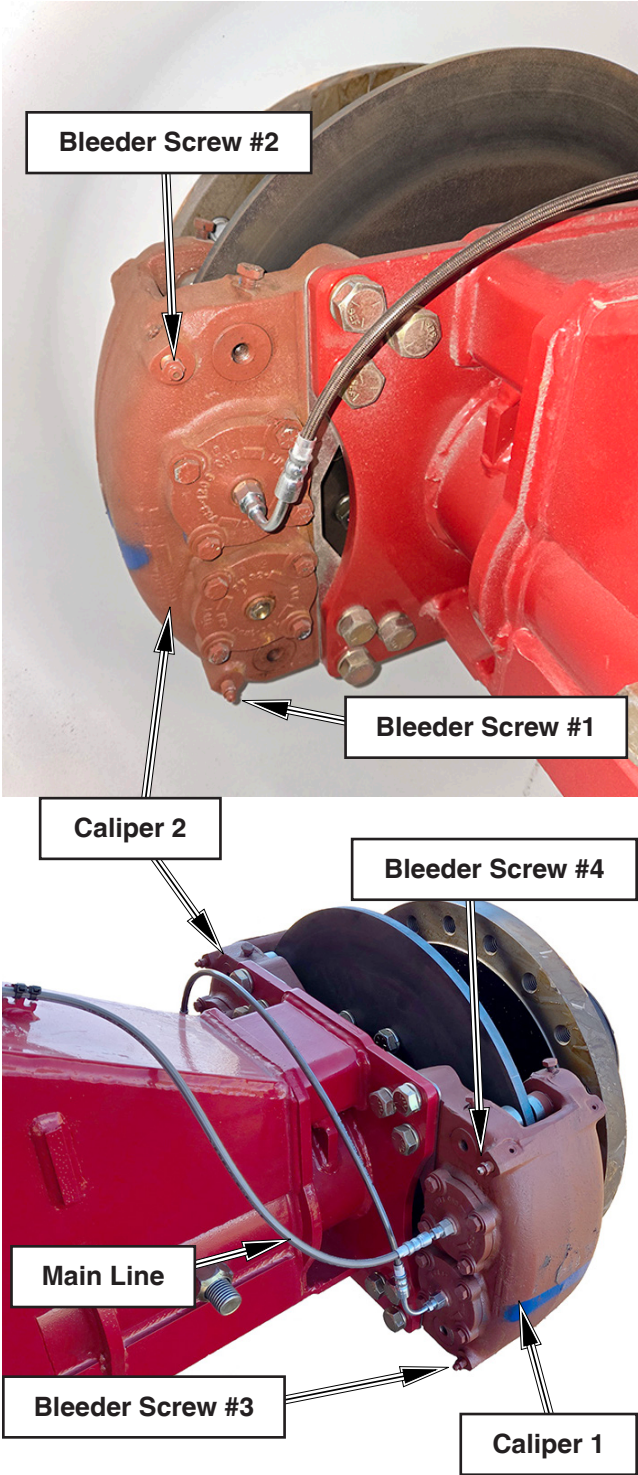

Maintenance

Brakes - Continued

Brake Pads

- Check brake pads for wear. If the thickness of the brake pad is 1/8" or less it is recommended to replace the brake pads.

To replace the brake pads use procedure below:

- Remove the wheels to gain adequate access to the calipers.
- Remove the bolt from each retaining pin.
- Slide the brake pad retaining pins out of the caliper and remove the brake pads.
- Install new brake pads and install retaining pins.
- Secure each retaining pins with bolt.

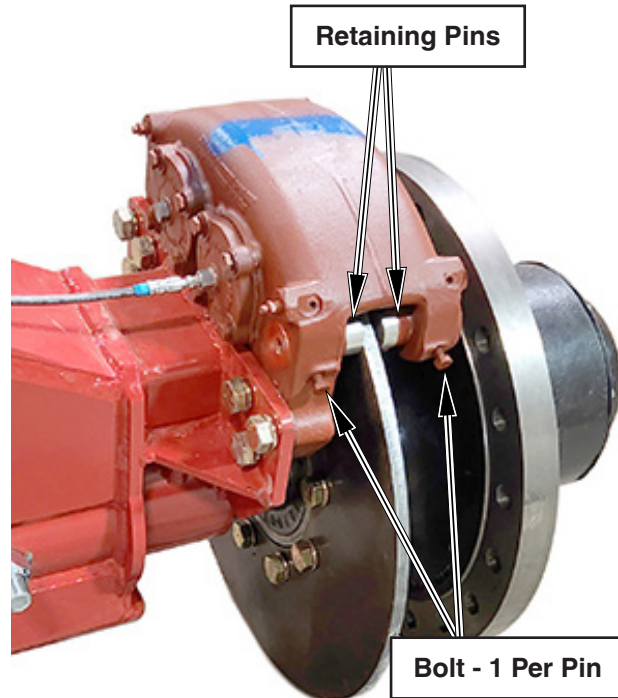

Caliper Pistons and Seal Replacement

- Remove the wheels to gain access to the calipers.
- Remove brake line and mounting bolts.
- Remove worn brake pads.
- Follow instructions in seal kit for piston removal and seal installation.
- Install new brake pads.
- Mount caliper to mounting plate and attach brake line.
- Bleed brakes.

Conveyor

4.1 Fluids and Lubricants

Grease:

Use an SAE multipurpose high temperature grease with extreme pressure (EP) performance. Also acceptable, SAE multipurpose lithium based grease.

Storing Lubricants:

Your machine can operate at top efficiency only if clean lubricants are used. Use clean containers to handle all lubricants.

- Store them in an area protected from dust, moisture and other contaminants.

4.1.1 Greasing:

NOTICE

GREASING HAZARD

Too much grease causes excessive overheating. Under-greasing accelerates equipment wear. No grease should be seen around bearings. If there is, too much grease was applied and the seal has ruptured!

IMPORTANT:

Grease bearings only one pump per month under normal usage conditions.

Bearing greasing frequency should be determined by usage and conditions.

1. Use a hand-held grease gun for all greasing.
2. Wipe grease fitting with a clean cloth before greasing, to avoid injecting dirt and grit.
3. All bearings are greasable, but require only minimal grease.
 - Recommended greasing is one small stroke every month. Be careful not to overgrease as this may push the seal out.
4. Replace and repair broken fittings immediately.
5. If fittings will not take grease, remove and clean thoroughly. Also clean lubricant passageway. Replace fitting if necessary

Maintenance

Conveyor - Continued

4.2 Servicing Intervals

The conveyor belt alignment is preset to run true under a condition of no load. It is important to check alignment and make adjustments, if required, during the initial few minutes of loaded operation.

Check bearings for wear daily.

The following recommended periods are based on normal operating conditions. Severe or unusual conditions may require more frequent lubrication and oil changes.

Schedules may vary depending on options and the motor contained on your equipment.

4.2.1 Every 10 Hours or Daily:

1. Inspect conveyor belt lacing for wear.
2. Check the conveyor belt tension daily while breaking-in the conveyor. Refer to Section 4.3.1
3. Check the conveyor belt alignment frequently during the first 10 hours of operation until it seats itself. Refer to Section 4.3.2
4. Inspect all rollers and bearings:
 - Check for play and wear.
 - Replace if necessary.

4.2.2 Every 50 Hours or Weekly:

5. Check the conveyor belt tension. Watch the tension more often while breaking-in the conveyor, because the belt may stretch. Refer to Section 4.3.1

Note: A properly tensioned belt will not slip when in operation.

6. Check the conveyor belt alignment.
 - How the belt is aligned to the rollers must be checked at the hopper, transition, and the discharge.

Watch the alignment more frequently during the first 10 hours of operation. It usually seats itself and can be checked weekly after that. Refer to Section 4.3.2

7. Check the condition of the rubber, hopper flashing. Be sure it still seals the hopper to prevent leaking.

If any product comes out of the hopper around the flashing, loosen flashing mounting screws and adjust. Retighten anchor screws and try running the conveyor again. Repeat until no grain is lost.

If the flashing is stuck to the belt, manually peel the flashing up and off the hopper.

4.2.3 Every 100 Hours or Monthly:

Note: Recommended greasing is one small stroke every month. Be careful not to over grease as this may push the seal out.

8. Grease hopper roller bearings.
9. Grease transition roller bearings.
10. Grease discharge roller bearings.

4.2.4 Every 200 hours or Annually:

11. Check the tube's straightness, horizontally and vertically.

If adjustment is necessary:

- Take tension off the cables by lifting the tube by the lift brackets.
 - Adjust eyebolts at the hopper end.
 - Remove support from the tube to view the result of the adjustment.
 - Repeat process until the tube is straight.
12. Wash the entire machine thoroughly using a water hose or pressure washer to remove all dirt, mud, debris or residue.
 - Wash the outside.
 - Wash around the hopper.
 - Leave the belt running while washing inside the tube and around the belt.

Conveyor - Continued

4.3 Maintenance Procedures

By following a careful service and maintenance program for your machine, you will enjoy many years of trouble-free service.

WARNING

ROTATING BELT HAZARD

Turn off engine, lock-out power and wait for all components to stop moving before adjusting the belt.

To check belt position, idle the engine, then rotate the belt slowly.

4.3.1 Conveyor Belt Tension:

The tension of the belt should be checked weekly, or more often if required, to be sure that it does not slip under load.

The tension of the belt should be checked weekly, or more often if required, to be sure that it does not slip under load.

1. Loosen the tail roller bearing housing bolts.
2. Move the adjustment bolts to correct the belt's tension.
3. Tighten the roller bearing housing.
4. Adjust equally on the other side to maintain alignment.

Note: To measure the belt tension, push on the underside of the belt. It should move up to 4 inches (10 cm). Any more than that and the belt needs more tension.

Maintenance

Conveyor - Continued

4.3.2 Conveyor Belt Alignment:

NOTICE

BELT DAMAGE HAZARD

Alignment of the belt must be checked at the hopper, transition and discharge. Inspect weekly. Unaligned belt will cause damage and void warranty.

NOTICE

BEARING FAILURE

If a roller is replaced, ensure both ends are evenly aligned with the frame before running. If not, bearing failure may occur.

The belt is properly aligned when it runs in the centre of all rollers.

Check frequently during the first few minutes of operation with a new belt, and then several times during the first 10 hours.

The new belt normally seats itself during the first 10 hours of operation and can be checked weekly after that.

WARNING

ROTATING BELT HAZARD

Idle the engine,
then rotate the belt slowly when checking
the alignment.

Turn off engine when adjusting rollers.

Belt Alignment at Tail and Transition Roller:

1. Rotate the conveyor belt slowly, and check the position of the belt on the tail roller.

Note: If belt is out of alignment, it will move to the loose side. Tighten loose side or loosen tight side.

2. Adjust one side of roller at a time.

- Loosen bearing housing, then adjust bolt.

3. Tighten the tail roller bearing housing.

4. Rotate the conveyor belt slowly, and check the position of the belt on the hopper roller.

- Repeat steps until the belt is centred.

5. Replace housing guard. Belt Alignment at Discharge Roller:

6. If necessary, remove the discharge spout to view the roller.

Note: If belt is out of alignment, it will move to the loose side. Tighten loose side or loosen tight side.

7. Adjust one side of roller at a time.

- Loosen the bearing housing, then adjust.

8. Tighten the discharge roller bearing housing.

9. Run the belt a couple of revolutions and check the alignment.

- Repeat steps until the belt runs centred.

10. Replace the bearing housing guard.

Conveyor - Continued

4.3.3 Conveyor Belt Replacement:

1. Rotate the conveyor belt until the Alligator® lacing is positioned under the tube, inside the wind guard, and is accessible.
2. Rotate the spring tension bolts, at the drive box, to their loosest position.
3. Pull all the slack to the lacing area.
4. Remove the lacing pin and open the belt



Fig 1 - Conveyor belt lacing

5. Loosen the belt from below the transition.
 6. Remove the containment plate from underneath the transition rollers.
- This will help when threading the new belt.

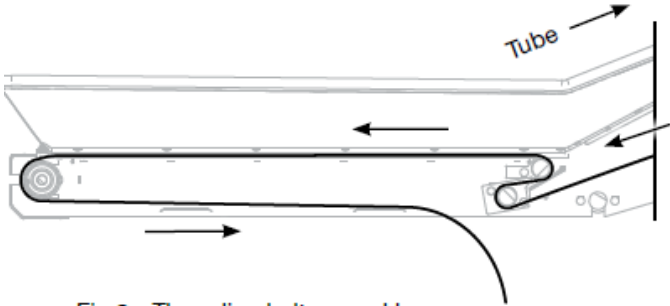

Fig 2 - Threading belt around hopper

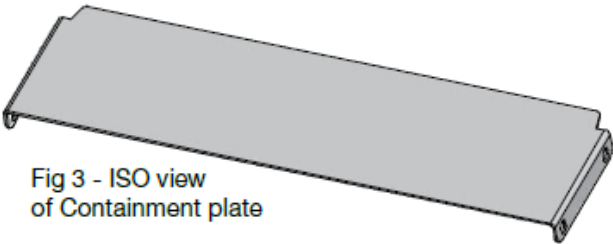

Fig 3 - ISO view of Containment plate

7. Attach the new belt to the end of the old belt which is hanging closest to the hopper.
8. Pull the end of the old belt which is coming from the direction of the discharge spout. The new belt will follow and be threaded into place.



Fig 4 - Containment plate in place

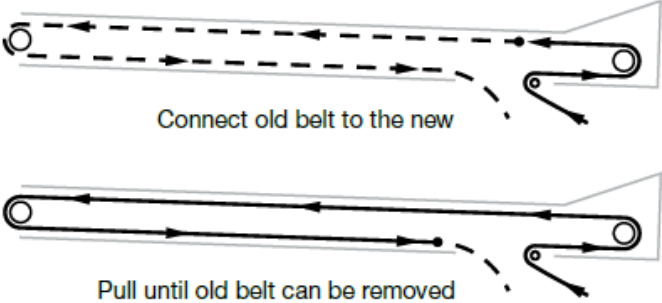

Fig 5 - Thread belt through conveyor

Maintenance

Conveyor - Continued

1. **IMPORTANT:** Reinstall the containment plate once the new belt is through the transition and around tail roller.

- Leave the belt hanging below transition.
- Do not fasten the belt lacing yet.

2. The Containment Plate will fit between the two weldments below the second transition roller. See Figure 79

- Note: The tongue of the plate will sit on top of the angle iron.

3. Insert the bolts from inside.

- The washers and nuts are fastened from the outside of the hopper.

4. Link the ends of the new belt lacing.

5. Push the lacing cable through the lacing to fasten belt.

Note: Cordless drill can be used to thread cable. Proceed slowly.

6. Cut off excess cable.

7. Crimp the lacing at one end to lock cable in place.

8. Cut and taper the corners, of the trailing end of the belt.

IMPORTANT: Taper the trailing belt corners, so they doesn't catch when rotating.

9. Set belt tension. Refer to Sections 4.3.1

10. Set the belt alignment. Refer to Section 4.3.2

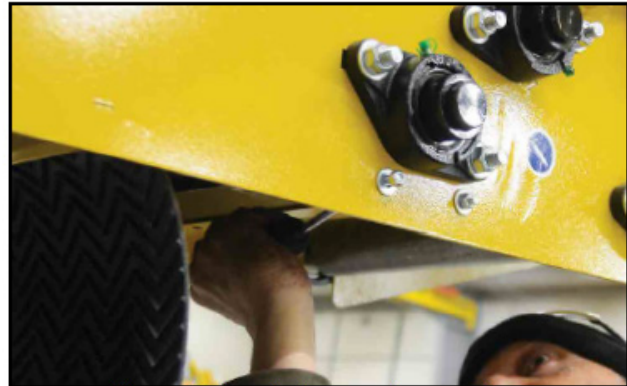

Fig 6 - Reinstall the containment plate



Fig 7 - Thread lacing cable

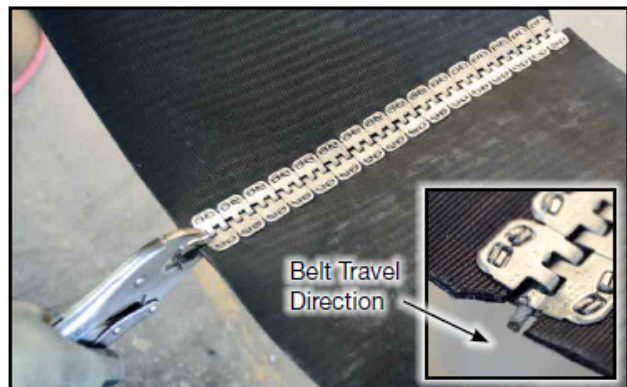

Fig 8 - Crimp lacing and taper belt corner

Conveyor - Continued

4.3.4 Standard Hopper Flashing Kit Replacement:

Flashing Kit Part #650506196
- Patent pending -

WARNING

HIGH SPRING TENSION

There is high spring tension on Hopper Hoop.
Hold hoop securely before working
on Hopper Canvas.

Sudden release of hoop will cause injury.
Keep Winch locked, and cable connected.

1. Securely, strap the hopper hoop to the frame.
2. Remove the existing rubber flashing from the hopper and transition.
3. Move transition rollers as far apart as possible.
4. Tension the belt and adjust its tracking.
5. Lay the rubber side flashing down on the angled side bracket of the hopper.
 - The end with the large hole, will lay under the tail flashing.
6. Position the tail flashing over the side flashing.
7. Insert the elevator bolts:
 - First, through the flat bar inside the canvas.
 - Second, through the tail flashing.
 - Third, through the large hole in the side flashing.
 - Fourth, fasten to the tail bracket on the frame.

Note: The side flashing should lay flush along their metal brackets.

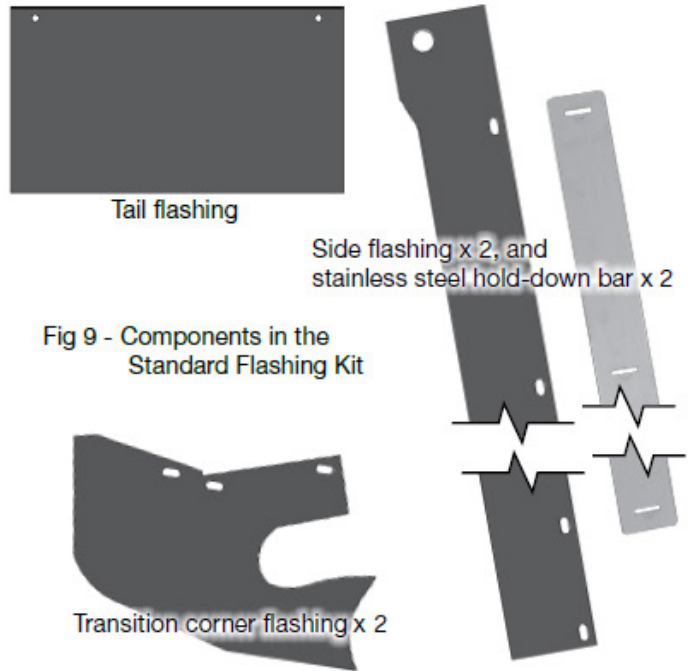

Maintenance

Conveyor - Continued

8. Lay the transition, corner flashing in place.
 - **IMPORTANT:** Work the flashing around the roller to cup it well.
 9. Lay the end of the side flashing over the transition flashing.
 10. Insert elevator bolt through the flat bar inside the canvas, side and transition flashing pieces and fasten to the hopper frame.
 - Do not tighten the bolts yet.
 11. Fasten the rest of the canvas at the transition.
 12. Sandwich the stainless steel hold-down bar between the canvas and the side flashing.
 - Align the bolt holes with the flashing and the flat bar inside the canvas.
 - Start at the centre, inserting elevator bolts and fastening them to the hopper frame.
 13. Push the stainless steel bar up behind the canvas, so the bolts are at the bottom of the slots.
- Note: As the side flashing wears from use, lower the stainless steel bar, so it continues to push the flashing tight against the belt.**
14. Install the rest of the flashing on both sides.
 - Do not tighten the bolts yet.
 15. **IMPORTANT:** Be sure the corner flashing fits tightly around the roller and deep into the transition.
 - It must cup the belt, tightly.
 16. Reuse the Flashing Clamps to hold corner flashing in place.
 - Use self-tapping screws to fasten them.
 17. Finally, tighten all the bolts and nuts.

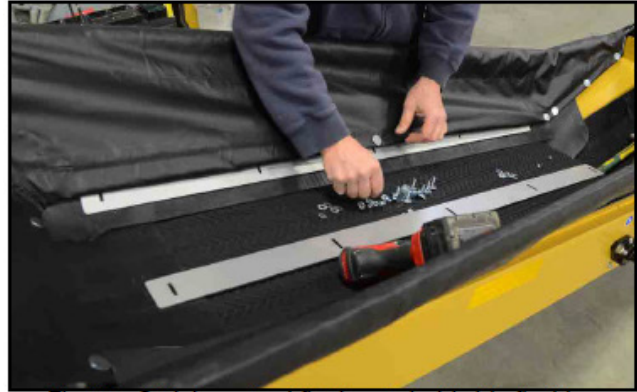

Fig 12 - Stainless steel flat bar to hold side flashing



Fig 13 - Corner flashing must fit tight around the belt



Fig 14 - Fasten flashing clamp



Fig 15 - Hopper is complete

Section 7: Storage

Section Contents

Preparing for Storage	7-2
General	7-2
Tank Clean Out For Storage	7-3
Removing From Storage.....	7-4
General	7-4
Monitor	7-4
Auger.....	7-4
Conveyor	7-4
Brakes	7-4

Storage

Preparing for Storage

General

- To insure longer life and satisfactory operation, store the 10 Series Air Cart in a shed.
- If building storage is impossible, store away from areas of main activity on firm, dry ground.
- Empty tanks (Refer to Unloading Tanks).
- Clean machine thoroughly.
- Inspect all parts for wear or damage.
- Avoid delays - if parts are required, order at the end of the season.
- Lubricate grease fittings (Refer to Lubricating Section).
- Tighten all bolts to proper specifications (Refer to Bolt Torque Chart).
- To prevent corrosion and damage by rodents, clean the interior of the tanks and metering systems thoroughly and wash with mild soapy water solution. Rinse with water and dry thoroughly (Refer to Tank Clean Out For Storage).
- A light coating of silicone lubricant or Fluid Film should be applied to all metal metering system components before storage.
- Avoid lubricant contact with seals.
- Avoid lubricant contact with grain and fertilizer hoses and tubes.
- Relieve tension on tank lids.
- Loosen clean-out doors.
- Remove batteries and charge fully. Store indoors.
- Relieve pressure from hydraulic system.
- Raise frame, block up and relieve weight from the tires.
- Cover tires with canvass to protect them from the elements when stored outside.
- Paint any surfaces that have become worn.

Note: When pressure washing the air cart, do not direct the spray directly at electric motors, connectors, or Auxiliary Power Unit (APU). Not all connectors are rated for pressure washing so water entry into the connector may occur.



Warning

Do not allow children to play on or around the machine.

Important

At no time should corrosive fertilizer or similar materials be allowed to remain in the tank or metering body cavity.

MORRIS PAINT

Part Number	Description
N75705	Red Touch-Up Aerosol Can
N75706	Black Touch-Up Aerosol Can
N75707	Silver Touch-Up Aerosol Can
N75708	Primer Touch-Up Aerosol Can
N76069	2 Part Epoxy Interior Tank Coating
K65885	White CF-546 Titan Aerosol Can

Important

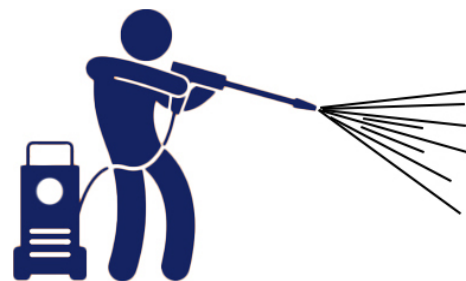

Do not contact electronic or electrical components and connectors with high pressure wash.

Preparing for Storage - Continued

Tank Clean Out For Storage

It is of high importance to thoroughly clean out the tanks post seeding!

The following procedure should be followed for all tanks:

- Be sure to shut the power source off from the tractor and shut the master switch off on the cart, blow off electric motors and wrap with plastic before washing.
- Open Collector bottom to allow material to exit
- Cycle flappers and adjust the flappers of the collectors into the middle position.
- Open Inspection Door and rotate seed plate to fully open position.
- Remove Pressure Chamber Covers and blow air around chamber to ensure it is free of debris.
- Blow out the metering system (gear boxes, meter wheels, electric motors) with compressed air before washing.
- Clean out the interior of the tanks of product and dust with pressure washer and soapy water.
- Clean the exterior of the tanks with a pressure washer, being careful to avoid direct contact of high-pressure spray to electrical components.

Note: Special attention is to be made to protect the electrical motors on the metering bodies. Use the covers that were supplied to protect the motors from high pressure spray. If needed, electric motors can be washed with low pressure water from garden hose.

- Seal the cart up and run the fans to remove the water from the airstream.
- Once the cleaning and water have been finished, blow the water from the meter bodies and leave the tanks open to allow the interior to dry.
- Once the interior of the tanks and internal meter body are dry, spray a coat of Fluid Film or silicone lubricant around the metering gear box and hardware attaching tank to meter body and to collector.
- If possible, leave the lids and inspection doors released from tension so the seal is able to relax.

After the cart is dried, any scratches or bare metal that is a result of filling the tanks and operation should be touched up with primer or paint available through your Morris Dealer

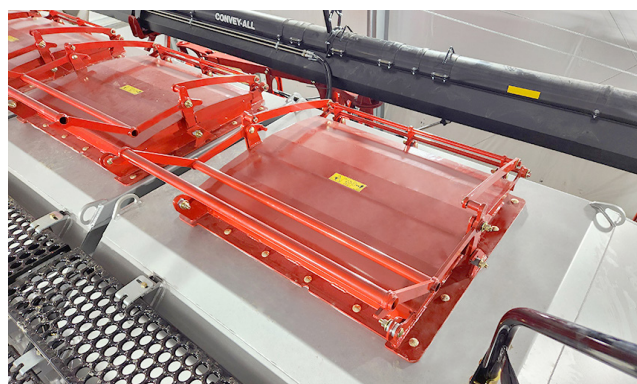
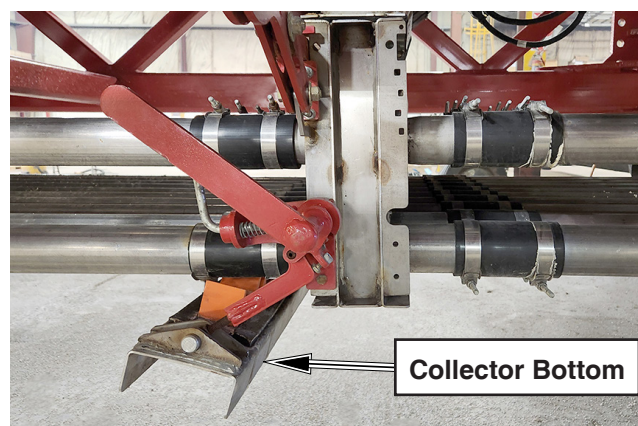
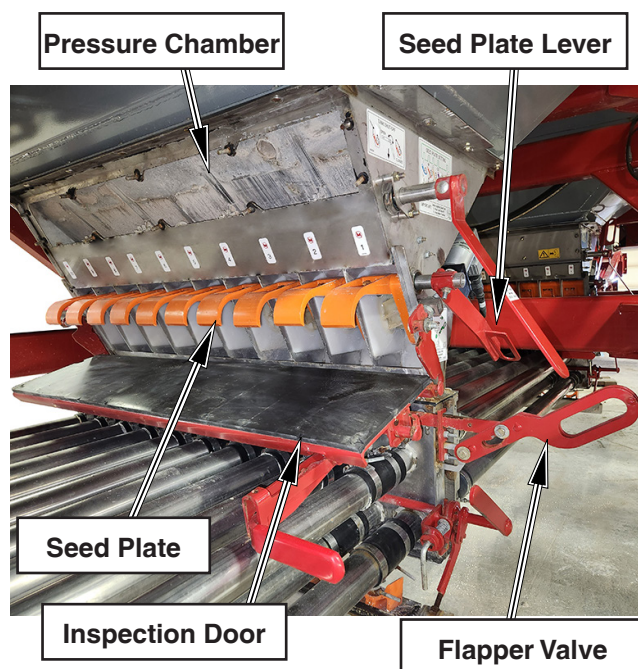

Storage

Removing From Storage

General

- Review Operator's Manual.
- Check tire pressure (Refer to Tire Pressure List).
- Clean machine thoroughly.
- Check each batteries condition and charge fully before installing.
- Tighten lid latches.
- Spray internal parts of the metering body with silicone lubricant or WD-40 or penetrating oil to loosen any corrosion buildup.
- Check for leaks (Refer to Maintenance Section).
- Lubricate grease fittings (Refer to Lubricating Section).
- Tighten all bolts to proper specifications (Refer to Bolt Torque Chart).

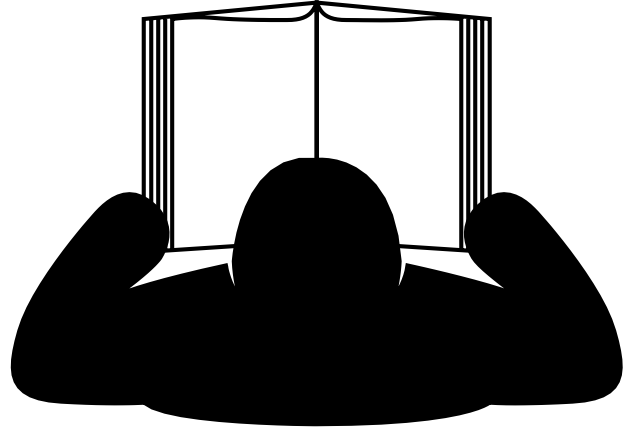

Monitor

Familiarize yourself with all monitor functions. Ensure all monitor “*settings*” are correctly set for the air cart/ seeding tool combination. Recognize and correct alarm conditions as indicated on the machine. See Monitor Manual for more details.

Check all wire harness connections for corrosion and use a dielectric spray to clean. Inspect all sensors for proper gap. See Monitor Manual for more details.

Auger

Inspect all augers used in handling the products for seeding. Run augers to clean out any debris inside auger so it does not get transferred to the tank.

Conveyor

Any conveyor that has sat idle for a season needs to go through a “break-in” period. See “Startup and Break-In” under the Operation Section.

Inspect all conveyors used in handling the products for seeding. Run conveyors to clean out any debris inside auger so it does not get transferred to the tank.

Brakes

Check the fluid level in the reservoir. Ensure battery is fully charged. Verify the brake system is working properly. See Operation Section.

Section 8: Troubleshooting

Section Contents

General	8-2
Delivery hoses plugged	8-2
Hydraulic fan will not turn	8-2
Fan turning too slow	8-2
Material flowing thru system when unit is stationary and the fan running	8-2
Material not being metered out.....	8-3
Material not being accurately metered out of the metering body	8-4
Plugged seed boots.....	8-4
APU	8-5
Batteries not charging.....	8-5
Metering System.....	8-5
Motor Torque High	8-5
Monitor.....	8-6
Monitor lights up but does not seem to work	8-6
No fan display.....	8-6
No display, no back light.....	8-6
Brakes.....	8-7
Fan.....	8-8
Air Guard System	8-9
Conveyor	8-10

Troubleshooting

Problem	Cause	Correction
General		
Delivery hoses plugged	Insufficient air flow.	Clean fan impeller blades. Clean fan intake screen. Increase fan rpm.
	Air Guard plugged	Clean Air Guard screen and radiator
	Hose sag.	Shorten hoses or add additional supports.
	Seed boots plugged with dirt.	Clean seed boots. See “Seed Boot Plugging” below.
	Hose obstruction.	Remove obstruction from hose.
	Air delivery hose partly off manifold.	Reinstall hose properly on manifold.
	Kinked hoses.	Straighten hoses and properly secure them to framework.
	Obstruction in divider head.	Remove access door and clear obstruction from appropriate outlets - be sure to use appropriate screens when filling.
	Exceeding machine’s delivery capabilities.	Reduce ground speed and speed up fan.
Poorly mounted hoses.	Reroute hoses.	
Hydraulic fan will not turn	Hydraulic hoses not connected properly to tractor.	Reverse hydraulic hoses.
	Insufficient oil flow.	Perform flow test.
Fan turning too slow	Flow to hydraulic motor.	Increase flow control setting.
	Low hydraulic pressure.	Set hydraulic pressure to 3000 psi.
Material flowing thru system when unit is stationary and the fan running	Damaged metering wheel.	Replace metering wheel.
	Incorrect Seed Plate Setting.	Adjust as required. See “Seed Plate Settings”

Troubleshooting

Problem	Cause	Correction
Material not being divided in distribution head	Head partially blocked.	Remove blockage and reinstall hose.
	Kinked hose running to shank.	Straighten or replace hose.
	Damaged distribution section on head.	Replace head with new one.
	Bent or damaged diffuser pipe.	Straighten or replace diffuser pipe.
	Secondary hose length.	See “Secondary Hose” in Operation Section.
	Tanks not pressurized.	Inspect lid seals. Clean pressurization hoses.
Material not being metered out	Motor to gearbox coupler	Replace.
	Massive air leak in tank, resulting in material being blown up out of the metering cup.	Repair the air leak. See “Air Leaks” in Maintenance Section. See “Tank Lid Adjustment” in Maintenance Section.
	Material caked up in tank.	Remove material and completely clean out the tank.
	Excessively wet material in tank.	Remove wet material and use reasonably dry material.
	Coupler bolt sheared.	Replace with Grade 8 bolt.

Troubleshooting

Problem	Cause	Correction
Material not being accurately metered out of the metering body	Air delivery hoses loose, cracked or pulled off.	Tighten the hoses, replace cracked hoses or install hoses pulled off their respective locations.
	Inlet screen to fan blocked off.	Clean off material that is blocking the fan screen.
	Incorrect Seed Plate Setting.	Adjust Seed Plate - See Operation Section.
	Seed Plate lock not adjusted correctly.	Adjust Seed Plate lock - See Operation Section.
	Material caked up above one or more of the metering cups.	Clean out caked up material.
	Excessively damp material in tank.	Use reasonably dry, fresh material only.
	Foreign obstruction in tank above metering wheels.	Remove obstruction, and always fill tanks through the screen.
	Caked up metering wheels on some or all of the metering cups.	Clean out the metering cups and wheels.
	Damaged metering wheels.	Replace damaged metering wheels.
	Collector Valves set incorrectly on Double Shoot machines.	See Operation Section.
Plugged seed boots	Air Leak in System.	Adjust lids and doors as necessary. Replace damaged seals.
	Meterbody pressurization hose disconnected.	Reconnect hose to meterbody/plenum.
	Backing up with openers near or in the ground.	Lift machine all the way up before backing up.
	Turning very sharp with openers near or in the ground.	Lift machine all the way up when making sharp turns.
	Lowering machine without any forward motion.	Always have forward motion when lowering machine.
	Worn openers or sweeps.	Replace openers.
	Severely bent or damaged boots.	Straighten or replace as required.
	Excessively wet conditions.	Change openers, operate when drier.
	Opener Adjustment.	See " <i>Opener Adjustment</i> " in Operation Section.

Troubleshooting

Problem	Cause	Correction
----------------	--------------	-------------------

APU

Batteries not charging	Alternator not running.	Ensure APU hydraulics are engaged. Motor coupler damaged. Replace.
	Poor battery connections.	Check terminals on batteries and alternator.
	Alternator not charging.	Check alternator voltage output, replace if necessary.

Metering System

Motor Torque High	Large debris stuck in meter roller.	Follow meter clean-out procedure.
	Incorrect Seed Plate Setting.	Adjust Seed Plate - See Operation Section.
	Tight gear box	Check for free turning gear box, replace if required

Troubleshooting

Problem	Cause	Correction
Monitor		
Monitor lights up but does not seem to work	Faulty monitor.	Replace monitor.
	Disconnected harness.	Connect harness.
No fan display	Incorrect gap between sensor and target.	Gap should be 1/16"
	Faulty sensor.	Replace sensor.
	Broken or shorted wire.	Replace or repair harness.
No display, no back light	Switched off.	Switch unit on.
	Poor power connections at the battery.	Ensure good connections. Replace monitor.
	Battery below 10.8 volts.	Check battery voltage.
	Temperature below -10C or above +40C.	Operate between -10C and +40C.

Troubleshooting

Problem	Cause	Correction
Brakes		
Indicator on "In Cab Controller" Shows no connection between towed and towing-vehicle.		Inspect plug and wiring for open circuit. Consult applicable wiring diagram to assure proper wiring connections.
Poor response time		Check and add brake fluid as required Bleed brake lines and devices Check input for adequate "charge" (12 VDC)
Inadequate or excessive Cart braking.		Adjust "gain" control on In-Cab Controller.
BrakeRite unit runs but does not build pressure.		Assure proper brake fluid level, add fluid and bleed the system as required.
BrakeRite unit does not run when the Tractor brake pedal is depressed		Verify and connect wire connections in the entire electrical circuit.
BrakeRite unit does not run when the in-cab manual override is activated.		Verify and connect wire connections in the entire electrical circuit.

Experience has shown that virtually all problems with BrakeRite units are the result of INCORRECT OR FAILED WIRING. If problems arise consult the wiring diagram and inspect all wiring and terminations.

Troubleshooting

Problem

Possible Cause	Possible Solution
----------------	-------------------

Fan

No Fan RPM

Fan speed sensor is misaligned.	Adjust fan speed sensor until speed is read.
Fan speed sensor has failed.	Replace fan speed sensor.
No hydraulic flow to fan motor.	Check that all hydraulic couplers are connected, engage Fan 1 and 2 hydraulic circuits.
No Fan RPM	Check 1/16" gap between fan speed sensor and fan plate. Make sure fan is turning, if not: Switch electrical connections: fan 1 with fan 2 at connector (don't move the sensors just switch the 3 pin duetsch plugs) if issue follows to new position situation is not rectified, return plugs to original position and replace sensor.

Fan Speed Cannot Exceed 3000 RPM

Fan speed sensor is misaligned.	Check 1/16" gap between fan speed sensor and fan plate.
Fan speed sensor has failed.	Replace fan speed sensor.
Inadequate hydraulic flow to fan motors.	Ensure tractor remote is fully stroked. Most newer tractors have hydraulic controllers that control flow rates. This is how the seed fan rpm is adjusted. Check if this fan is not performing as high as expected.

Troubleshooting

Problem

Possible Cause	Possible Solution
----------------	-------------------

Air Guard System

Fluctuating pressures on pressure gauges and strange noises coming from fan motor.

High return line pressure	The logic cartridge on the BP System is set to 750psi. Any value close to or above that will cause fluctuations and issues with fan speed. Reduce return line pressure to fix this problem.
Faulty quick disconnect couplers	Replace quick disconnect couplers, inspect ball valve to ensure proper working order
Restriction in return line due to small fitting	Replace fitting with a larger one
Logic cartridge is contaminated	Clean or replace the logic cartridge as needed

Fan Won't Run

High return line pressure	The logic cartridge on the BP System is set to 750psi. Any value close to or above that will cause fluctuations and issues with fan speed. Reduce return line pressure to fix this problem.
Quick couplers are disconnected	Ensure that quick couplers are connected properly
Logic cartridge is contaminated	Clean or replace the logic cartridge as needed
Hoses are hooked up incorrectly	Consult owner's manual to see proper installation of hoses

Cannot get fan speed up to normal levels

Pressure/flow is too low at tractor	Increase pressure/flow
-------------------------------------	------------------------

Troubleshooting

Problem

Possible Cause	Possible Solution
----------------	-------------------

Conveyor

Conveyor belt doesn't turn or is slipping

Hopper flashing may be stuck to belt, because it is running dry and rubber is heating up	Turn off unit! Manually peel flashing up and off hopper. Then run dry product through to create barrier between flashing and belt
Conveyor belt is loose	Tighten and align
	The belt has stretched. Shorten belt
Conveyor belt not pinched enough	Inside drive box there is a drive roller and pinch roller. Be sure the belt is snug between both rollers.
Conveyor belt frozen to tube from operating in high humidity conditions in extreme cold	Remove conveyor from area of high humidity and continue to run empty so the belt dries prior to freezing
Hydraulic system - valve, pump or motor is malfunctioning	Check and adjust pressure set screw on valve. Test flow from pump. Check for oil leaks under motor. Replace what is needed.
Hydraulic pressure may be low, check gauge. It should be above 2,000 psi	Check hydraulic pump. Replace if necessary
Set screw (relief valve) on Dtent control valve on belt drive valve isn't set correctly	IMPORTANT: Do not run hydraulic motor during this adjustment. Turn the set screw all the way in, then turn back out 1-1/2 turns. Note: Turning out increases volume of flow, turning in increases pressure.
Seized bearing	Check all bearings, Replace any that are rough or seized
Hydraulic motor on drive roller may be damaged	Hydraulic motor may need to be replaced
Belt/roller is jammed	Check for sticks, stones, other objects jammed in belt drive area and remove

Belt is slowing down

Problem with 2 stage pump	Check flow of the pump. Check pump pressures. Replacement of entire pump may be needed.
---------------------------	---

Low conveying capacity

Conveyor belt not tight enough	Tighten conveyor belt
Roller lagging is worn out	Replace roller or have it relagged
Conveyor belt not pinched enough	Inside drive box there is a drive roller and pinch roller. Be sure the belt is snug between both rollers.
Conveyor angle exceeds 30 degrees	Reposition with a lower tube slope

Troubleshooting

Problem

Possible Cause	Possible Solution
----------------	-------------------



Conveyor belt won't align

Roller lagging may be worn	Replace roller or have it re-lagged
----------------------------	-------------------------------------

Conveyor Belt Fraying

Belt not aligned	Align and adjust tension the belt
------------------	-----------------------------------

Product leakage

 <p>Corner Flashing may not be cupping the roller tight enough.</p>	 <p>Loosen the Flashing Clamp, then adjust the rubber flashing so it is tight around the roller</p>
<p>Product may be getting under the belt at the hopper, traveling up inside the belt and leaking off discharge end</p>	<p>Replace hopper flashing</p>

Troubleshooting

Notes



www.morrisequipment.ca

1891 Albert Street North,
Regina, Saskatchewan
S4R 8R7 Canada
Phone: 306-933-8585
Fax: 306-933-8626

It is the policy of Morris Equipment Ltd. to improve its products whenever it is possible to do so. Morris Equipment reserves the right to make changes or add improvements at any time without incurring any obligation to make such changes on machines sold previously.