



OPERATOR'S MANUAL

**9 Series
ICT AIR CART**

Table of Contents

Section 1:	
Safety	1-1
Signal Words	1-2
General Operation	1-3
Tractor Operation	1-3
Chemicals.....	1-4
Transporting.....	1-5
Hydraulics.....	1-5
Maintenance.....	1-6
Storage.....	1-6
Safety Signs	1-7
Decals	1-10
Front.....	1-12
Rear	1-13
Left Side - Tow Between.....	1-14
Right Side - Tow Between	1-15
Left Side - Tow Behind.....	1-16
Right Side - Tow Behind	1-17
Top.....	1-18
ICT Meter Body.....	1-19
Lighting and Marking.....	1-20
Conveyor Safety	1-22
General	1-22
Safety Signs	1-23
Section 2:	
Specifications	2-1
9365, 9450 and 9535 - Tow Behind.....	2-2
9365 and 9450 - Tow Between.....	2-3
9445, 9550 and 9650 - Tow Behind.....	2-4
9445, 9550 and 9650 - Tow Between	2-5
9555, 9680 and 9800 - Tow Behind.....	2-6
9555, 9680 and 9800 - Tow Between	2-7
91000 - Tow Behind	2-8
Section 3:	
Checklist	3-1
Manuals.....	3-2
Parts Manual	3-2
Assembly Manual.....	3-2
Checklist.....	3-3
Section 4:	
Introduction	4-1
Introduction.....	4-2
Standard Features.....	4-3
Hydraulic Auger.....	4-3
Full Bin Indicator.....	4-4
Options.....	4-4
Hydraulic Conveyor	4-4
Digi-Star Weigh Scale	4-4
Dual Fan.....	4-5
Section 5:	
Operation	5-1
Application.....	5-4
Tractor.....	5-4

Table of Contents

Monitor Installation	5-5
Monitor Harness.....	5-6
Hitching to Tractor (Seeding Tool or Tow Behind Cart)	5-7
Tractor Drawbar Requirements	5-7
9365 and 9450 - Tow Between	5-8
9445, 9550 and 9650 - Tow Between	5-9
9555, 9680 and 9800 - Tow Between	5-9
Hitching to Seeding Tool (Tow Behind Cart)	5-10
Hitching Front Castor (Tow Behind Cart)	5-10
Hitching to Seeding Tool (Tow Behind Cart).....	5-11
Hydraulic Connections	5-13
Unhitching from Seeding Tool (Tow Behind Cart).....	5-14
Unhitching from Tractor (Seeding Tool or Tow Behind Cart).....	5-14
9365 and 9450 - Tow Between	5-14
9445, 9550 and 9650 - Tow Between	5-15
9555, 9680 and 9800 - Tow Between	5-15
Unhitching from Seeding Tool (Tow Behind Cart).....	5-16
Quad Steer Operation	5-17
Brakes	5-18
In-Cab Brake Controller.....	5-18
Operation	5-19
Installation.....	5-20
Transport.....	5-22
Speed.....	5-22
Lights	5-22
Tow Hitch (Tow Behind Units).....	5-22
Preparing VR System	5-23
Hydraulic Motor Solenoid	5-23
Verify VR Hydraulic Assembly	5-23
Hydraulic Diagram.....	5-24
Metering System.....	5-25
Secondary Hose Installation	5-26
Seed Plate Setting	5-27
Seed Plate Adjustment.....	5-28
Bin Level Adjustment.....	5-29
Full Bin Indicator.....	5-29
Digi-Star Weigh Scale.....	5-30
Hydraulic Assist Conveyor/Auger.....	5-31
Remote Controller Operation	5-31
Auger.....	5-32
Manual Arms	5-32
Hydraulic Assisted Arms.....	5-33
Extension Hopper.....	5-34
Conveyor	5-35
Hydraulic Assisted Arms.....	5-35
Conveyor Storage Position	5-36
Conveyor Belt Speed	5-36
Operation	5-37
Startup and Break-In.....	5-37
Conveyor Adjustments and Maintenance.....	5-38
Cleaning/Inspecting the Conveyor - 8 hours or Daily	5-39
Conveyor Belt/Tail End Care.....	5-39
Semi Trailer Filling Positions	5-40
Semi Trailer Dump Positions	5-53
Filling Tank	5-57

Table of Contents

Unloading Tanks	5-61
Rate Calibration.....	5-63
Metering Rate Adjustment	5-66
Seeding Fine Seeds (Canola, Mustard, etc.).....	5-66
Applying Inoculant.....	5-66
Hydraulic Fan Drive	5-67
Fan Speed Recommendations	5-68
Plenum Settings	5-71
Double Shoot Settings.....	5-72
Collector Valve Settings.....	5-72
Flapper Valve Run Test.....	5-72
Operating Guidelines.....	5-73
Check Tire Pressures	5-73
Level Seeding Tool	5-73
Worn Seeding Tool Parts	5-73
Packing	5-73
Turning.....	5-74
Seed Rate Settings	5-74
Fertilizer Application	5-74
Fan Setting	5-74
Product Application.....	5-74
Adjustments and Operational Checks	5-75
Checking Seed Flow	5-75
Moisture Alert	5-75
Air Leaks	5-75
Tank Low in Product	5-75
Monitor	5-76
General Field Operation	5-76
Section 6:	
Maintenance.....	6-1
General.....	6-2
Safety	6-2
Tighten Bolts	6-3
Tires	6-4
Daily Maintenance.....	6-5
Lubrication.....	6-6
Air Delivery System	6-7
General	6-7
Tank Lid Adjustment	6-8
Inspection Door Adjustment	6-9
Clean Out Door Adjustment	6-10
Air Leak Check.....	6-11
Fan	6-12
Rotor Clearance	6-13
Hoses.....	6-13
Equalizers	6-14
Hydraulic Orbit Motor.....	6-15
Hydraulics.....	6-16
Wheel Bearings.....	6-17
Quad Steer	6-18
Dual Wheels	6-18
Dual Wheel 9800 and 91000 - 38 Rims.....	6-19
Rim Identification.....	6-19
Titan Rim.....	6-20

Table of Contents

Moveero (GKN) Rim.....	6-22
Seed Plate Adjustment.....	6-26
Tie Rod - Tow Between.....	6-27
Conveyor.....	6-28
Brakes.....	6-40
Fill Reservoir.....	6-40
Bleeding the Brakes.....	6-40
Brake Pads.....	6-41
Caliper Pistons and Seal Replacement.....	6-41
Section 7:	
Storage.....	7-1
Preparing for Storage.....	7-2
General.....	7-2
Metering Body Storage.....	7-3
Removing From Storage.....	7-4
General.....	7-4
Monitor.....	7-4
Auger.....	7-4
Conveyor.....	7-4
Brakes.....	7-4
Section 8:	
Troubleshooting.....	8-1
General.....	8-2
Delivery hoses plugged.....	8-2
Hydraulic fan will not turn.....	8-2
Fan turning too slow.....	8-2
Material flowing thru system when unit is stationary and the fan running.....	8-2
Material not being divided in distribution head.....	8-2
Material not being metered out.....	8-3
Material not being accurately metered out of the metering body.....	8-4
Plugged seed boots.....	8-5
VRT System.....	8-6
Motors will not turn in Manual Mode (Controller OFF).....	8-6
Motors will not turn in Operation Mode (Controller ON).....	8-6
Motors turn continuously in Operation Mode.....	8-6
Motors turn continuously in Calibration Mode.....	8-6
Monitor.....	8-7
Monitor lights up but does not seem to work.....	8-7
No fan display.....	8-7
No ground speed display.....	8-7
No display, no back light.....	8-7
Bin indicates always empty.....	8-7
Bin indicates always full.....	8-7
Conveyor.....	8-8
The conveyor is vibrating.....	8-8
Capacity is too low.....	8-8
The conveyor plugs.....	8-8
Driveline shear bolt shears frequently.....	8-8
Cleated belt is slipping or loose.....	8-9
Cleated belt is rubbing side of housing or cleats are coming loose or wearing.....	8-9
Brakes.....	8-9

Section 1: Safety

Section Contents

Signal Words	1-2
General Operation	1-3
Tractor Operation	1-3
Chemicals	1-4
Transporting	1-5
Hydraulics	1-5
Maintenance	1-6
Storage	1-6
Safety Signs	1-7
Decals	1-10
Front	1-12
Rear	1-13
Left Side - Tow Between	1-14
Right Side - Tow Between	1-15
Left Side - Tow Behind	1-16
Right Side - Tow Behind	1-17
Top	1-18
ICT Meter Body	1-19
Lighting and Marking	1-20
Conveyor Safety	1-22
General	1-22
Safety Signs	1-23

Safety

SAFETY-ALERT SYMBOL



Watch for this symbol. It identifies potential hazards to health or personal safety. It means:

ATTENTION - BE ALERT.
Your Safety is involved.

Familiarize yourself with the location of all decals. Read them carefully to understand the safe operation of your machine.

Signal Words

The words **DANGER**, **WARNING** or **CAUTION** are used with the safety alert symbol. Learn to recognize the safety alerts, and follow the recommended precautions and safe practices.

Three words are used in conjunction with the safety-alert symbol:



DANGER

Indicates an imminently hazardous situation that, if not avoided, will result in **DEATH OR SERIOUS INJURY**.



WARNING

Indicates a potentially hazardous situation that, if not avoided, could result in **DEATH OR SERIOUS INJURY**.



CAUTION

Indicates a potentially hazardous situation that, if not avoided, may result in **MINOR OR MODERATE INJURY**.

Replace any **DANGER**, **WARNING**, **CAUTION** or instructional decal that is not readable or is missing. The location and part number of these decals is identified later in this section of the manual.

The words **Important** and **Note** are not related to personal safety but are used to give additional information and tips for operating or servicing this equipment.

IMPORTANT: Identifies special instructions or procedures which, if not strictly observed could result in damage to, or destruction of the machine, process or its surroundings.

NOTE: Indicates points of particular interest for more efficient and convenient repair or operation.

General Operation

- **DO NOT RIDE!!** Do not allow riders on the implement when in motion.
- Do not allow extra riders in the tractor unless an instructor seat and seat belt are available.
- **Check behind** when backing up.
- **Reduce speed** when working in hilly terrain.
- Never allow anyone within the immediate area when operating machinery.
- **Keep all shields in place**, replace them if removed for service work.
- Always lock auger attachment in raised position.
- Keep hands clear of tank opening when closing lid. Keep lid seal clean to ensure proper sealing.
- **Do Not enter tank unless another person is present and the tractor engine has been shut off.**

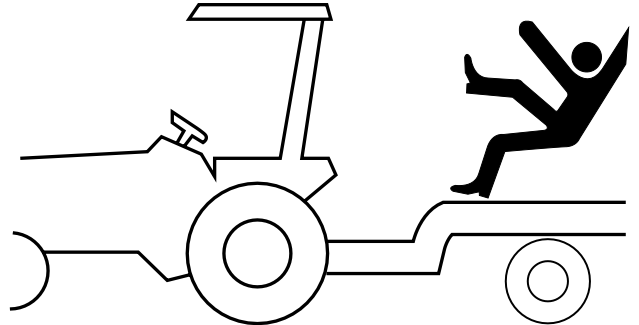

Tractor Operation

- Be aware of the correct tractor operating procedures, when working with implements.
- Review tractor operator's manual.
- Secure hitch pin with a retainer and lock drawbar in centre position.

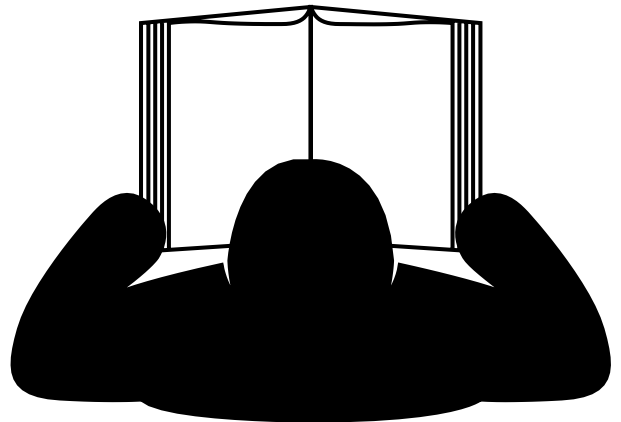

Safety

Chemicals

- **Use extreme care** when cleaning, filling or making adjustments.
- **Always read** granular chemical or treated seed manufacturer's warning labels carefully and follow them.
- Wear close fitting clothing and appropriate personal protective equipment for the job as specified by the chemical and/or seed manufacturer.
- **Always wear** safety goggles, breathing apparatus and gloves when handling granular chemical or treated seed.
- **Do not feed** any treated seed to livestock. Treated seed is poisonous and may cause harm to persons or livestock.
- **Wash exposed skin immediately** - do not leave chemicals on your skin.
- **Properly store** chemicals in original containers with labels intact per the manufacturer's instructions.
- Always follow the manufacturer's operating instructions and warning labels when operating an ammonia tank with the equipment.
- **Do Not enter tank unless another person is present and the tractor engine has been shut off.**



Danger

Failure to comply may result in serious injury or death.

Read Operator's Manual and decals on **Ammonia** tank before operating air cart. Become familiar with all warnings, instructions, and controls.

Always wear gloves and goggles when transferring or handling ammonia.

Always stay clear of hose and valve openings.

Always be sure pressure is relieved before disconnecting hoses or parts.

Always secure connecting parts and safety chains before towing ammonia trailer.

Always have ample water available in case of exposure to ammonia liquid or gases.

Transporting

- **Be aware** of the height, length and width of implement. Make turns carefully and be aware of obstacles and overhead electrical lines.
- Empty tanks before transporting. Do Not Exceed 20 mph (32 kph) with an empty air cart.
- Use an agricultural tractor that is large enough with sufficient braking capacity so that the weight of the loaded equipment towed does not exceed 1.5 times the weight of the tractor.
- Use flashing amber warning lights, turn signals and SMV emblems when on public roads.
- Do not transport in poor visibility.
- The slow moving vehicle (SMV) emblem and reflectors must be secured and be visible on the machine for transport.
- Avoid soft surfaces, the additional wing weight on the centre wheels could cause the machine to sink.
- Ensure safety chain is attached correctly to the towing vehicle and the hitch of the air cart.
- Check that wings are firmly seated in transport wing stops, and lock pins installed.
- Secure transport locks on depth control cylinders.
- Be familiar with, and adhere to, local laws.

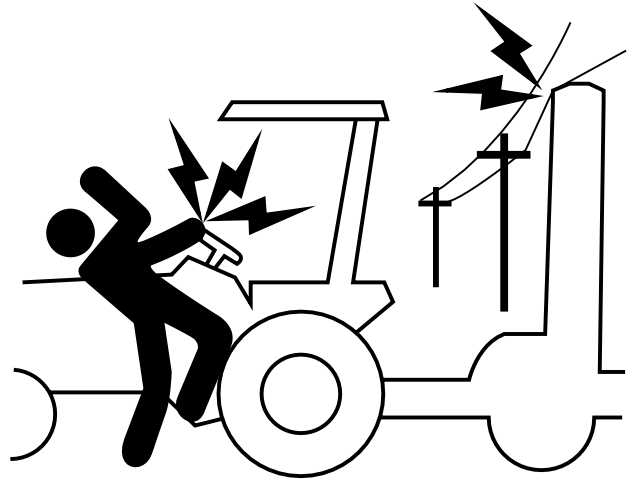

Hydraulics

- **Do not** search for high pressure hydraulic leaks without hand and face protection. A tiny, almost invisible leak can penetrate skin, thereby requiring immediate medical attention.
- Use cardboard or wood to detect hydraulic leaks - never your hands.
- Double check that all is clear before operating hydraulics.
- **Never** remove hydraulic hoses or ends with machine elevated. Relieve hydraulic pressure before disconnecting hydraulic hoses or ends.
- Maintain proper hydraulic fluid levels.
- Keep all connectors clean for positive connections.
- Ensure all fittings and hoses are in good condition.
- Do not stand under wings.



Safety

Maintenance

- **Shut tractor engine off** before making any adjustments or lubricating the machine.
- **Block** machine securely to prevent any movement during servicing.
- Wear close fitting clothing and appropriate personal protective equipment for the job.
- **Always wear** safety goggles, breathing apparatus and gloves when working on seeder filled with granular chemical or treated seed per the manufacture's instructions.
- Do not modify the machine.

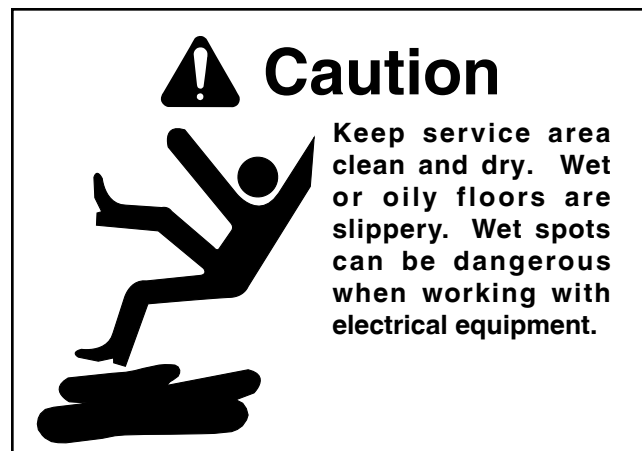
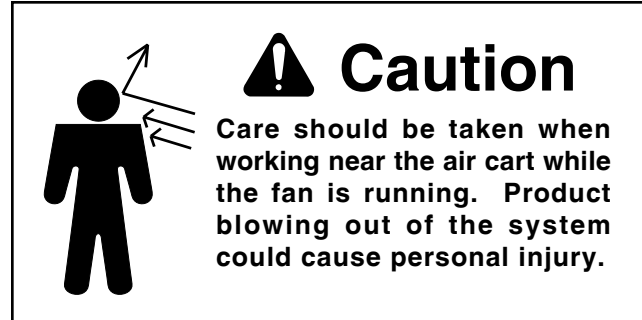

Storage

- Store implement away from areas of main activity.
- Level implement and block up securely to relieve pressure on jack.
- Do not allow children to play on or around stored implement.
- Refer to Storage Section for more details.

Safety Signs

⚠ DANGER

CONFINED SPACE HAZARD
To Prevent Serious Injury or Death:

- Do not enter tank.
- Be aware of and follow safety precautions
- Read and follow chemical manufacturer's safety instructions.

N36262

⚠ DANGER

GUARD MISSING
When this is visible
DO NOT OPERATE

N32799

⚠ DANGER

- Hydraulic motor or engine and exhaust system becomes extremely hot from operation.
- Keep hands, feet and clothing away from moving parts.
- Keep all covers, shrouds and guards in place.

N19023

⚠ WARNING

Personal injury or property damage may result from loss of control.

- Always use large enough tractor with sufficient braking capacity.
 - > Weight of fully loaded implement should not be more than 1.5 times weight of tractor.
- Maximum recommended towing speed is 20 mph (32 km/h).
- Use flashing amber warning lights and SMV emblem when on public roads, except where prohibited by law.
- Refer to tractor and implement Operator's Manuals for weights and further information.

N24301

⚠ WARNING

CRUSHING HAZARD
To prevent serious injury:

- Keep hands clear of auger arm top when moving auger.
- Use handle.

N36255

⚠ WARNING

BURN HAZARD
To Prevent Serious Injury:

- Do Not Touch hydraulic motor or oil lines.
- Hydraulic motor and oil lines become extremely hot from operation.

N36265

⚠ WARNING

MOVING PART HAZARD
To prevent serious injury or death from moving parts:

- Secure any guards and shields before starting.
- Keep hand, feet, hair and clothing away from moving parts.
- Disconnect and lockout power source before adjusting or servicing.
- Sprockets and chains CAN START MOVING even though Air Cart is stationary.

N29355

⚠ CAUTION

CRUSHING HAZARD
• STAND CLEAR - Stairway may fall rapidly when unlatching lock pin.

N56999

⚠ CAUTION

To avoid injury, do not open lids while fan is operating. Air gust may contain dust and particles.

N15084



Familiarize yourself with the location of all decals. Read them carefully to understand the safe operation of your machine.

Safety

Safety Signs - Continued

IMPORTANT

BEFORE FILLING TANK

- Ensure each meter is set correctly as described in the Operator's Manual.
- Ensure Tank clean out door is fully closed.

BEFORE APPLYING PRODUCT

- Set rate according to the procedure and rate chart described in the Operator's Manual.
- Take a sample and adjust the rate, if necessary.

AIR LEAKS AFFECT METERING ACCURACY

- Ensure all seals are properly positioned and all lids are tightly closed.

N42356

IMPORTANT

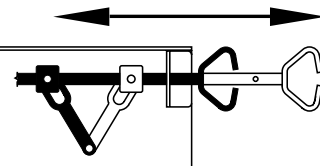

Cycle Collector Valve Daily
to ensure free movement.
Minimum of 5 cycles.

N36264

IMPORTANT

ENSURE THAT ALL WHEEL NUTS ARE TORQUED TO THE FOLLOWING:

- 5/8" Tapered Wheel Nut - 150 ft-lbs (203 Nm)
- 3/4" Flanged Wheel Nut - GR.8 - 450 ft-lbs (610 Nm)
- 7/8" Flanged Wheel Nut - GR.8 - 525 ft-lbs (711 Nm)
- 22mm Flanged Wheel Nut - GR.10.9 - 500 ft-lbs (677 Nm)
- 24mm Wheel Bolt - GR.10.9 - 590 ft-lbs (800 Nm)

N55695

IMPORTANT

PREVENT CORROSION

Clean the Metering Body (Including Air Passages)
and the Collector Body. A light coating of
Silicone Lubricant or WD-40 or Penetrating Oil
should be applied before storage.

N21604

MINIMUM TRAVEL

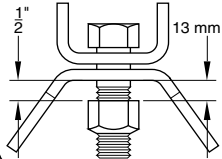

IMPORTANT

TANK BOLTS MUST BE A LOOSE FIT.
DO NOT REPLACE WITH SHORTER BOLTS.

N29729



Familiarize yourself with the location of all decals. Read them carefully to understand the safe operation of your machine.

Safety Signs - Continued



! DANGER

ROTATING FLIGHTING HAZARD

Keep away from auger intake.
Keep intake shield in place and in good working order. Do not modify.

FAILURE TO HEED WILL RESULT IN SERIOUS INJURY OR DEATH.

MADE IN CANADA 17098

This safety sign features a black and white illustration of a person being struck by a rotating auger. The sign has a black header with a white exclamation mark in a triangle and the word 'DANGER' in bold white letters. The main illustration shows a person falling back as a large auger bit strikes them. Below the illustration, the text is in black on a white background, with the hazard name in bold. At the bottom, it includes the manufacturer's information.



! DANGER

ELECTROCUTION HAZARD

This equipment is not insulated.
Keep equipment away from overhead power lines and devices.
Electrocution can occur without direct contact.
Fully lower equipment before moving.

FAILURE TO KEEP AWAY WILL RESULT IN SERIOUS INJURY OR DEATH.

MADE IN CANADA 17102

This safety sign features a black and white illustration of a person being struck by an overhead power line. The sign has a black header with a white exclamation mark in a triangle and the word 'DANGER' in bold white letters. The main illustration shows a person on a piece of equipment being struck by a power line, with another person nearby also being struck. Below the illustration, the text is in black on a white background, with the hazard name in bold. At the bottom, it includes the manufacturer's information.



Familiarize yourself with the location of all decals. Read them carefully to understand the safe operation of your machine.

Safety

Safety Signs - Continued

Decals

Part #	Description	QTY
Tanks		
N53153	Decal - "MORRIS" (9" height)	2
N53154	Decal - Morris Bullet (12" Diameter)	1
N53155	Decal - Morris Bullet (47" Diameter)	1
N53156	Decal - ARROW	2
N53157	Decal - "9365" (2 tank Small Frame)	2
N53159	Decal - "9450" (3 tank Small Frame)	2
N53160	Decal - "9535" (4 tank Small Frame)	2
N53158	Decal - "9445" (2 tank Large Frame)	2
N53180	Decal - "9550" (3 tank Large Frame)	2
N53181	Decal - "9650" (4 tank Large Frame)	2
N55820	Decal - "9555" (2 tank)	2
N53182	Decal - "9680" (3 tank)	2
N53183	Decal - "9800" (4 tank)	2
N53195	Decal - "91000" (4 tank)	2
N56210	Decal - ICT	2
N53185	Decal - Tank Size - 86 Bu	1
N53186	Decal - Tank Size - 107 Bu	1
N53187	Decal - Tank Size - 133 Bu	1
N53188	Decal - Tank Size - 162 Bu	1
N53189	Decal - Tank Size - 182 Bu	1
N53190	Decal - Tank Size - 221 Bu	1
N53191	Decal - Tank Size - 265 Bu	1
N53192	Decal - Tank Size - 284 Bu	1
N53193	Decal - Tank Size - 331 Bu	1
N53194	Decal - Tank Size - 349 Bu	1

Part #	Description	QTY
--------	-------------------	-----

Rear Wheels

N56050	Decal - Wheel Torque	2
--------	----------------------------	---

Stair Way

N56999	Decal - Warning - "Stand Clear"	2
--------	---------------------------------------	---

Safety Signs - Continued

Decals - Continued

Part #	Description	QTY
Frame		
C31201	Decal - Warning	1
D13705	Decal - Warning - "No Riders"	2
N19023	Decal - Danger	1
N24301	Decal - Warning	1
N36261	Decal - Warning - "Over Head Hazard"	1
N36264	Decal - Important - "Cycle Collector Valve Daily"	1 per metering Body
N36263	Decal - Warning - "Burn Hazard"	1
N36255	Decal - Warning - "Crushing Hazard"	1
N36259	Decal - "Open/Close"	2 per metering Body
N36262	Decal - Danger - "Confined Space Hazard"	1 per Lid
N15094	Decal - Caution - "To Avoid Injury"	1 per Lid
N42356	Decal - Important - "Before Filling Tank"	1 per Lid
N21604	Decal - Important - "Prevent Corrosion"	1
N45429	Decal - Patented	1
N55496	Decal - Patented	1
N58899	Decal - Patented - ICT	1 per metering Body
N29355	Decal - Warning - "Moving Part Hazard" (VRT ONLY)	1
N32799	Decal - Danger - "Guard Missing" (VRT ONLY)	3
N56167	Decal - ICT Seed Plate Settings	1 per metering Body
N45427	Decal - "Seed Plate Usage" (VRT ONLY)	1
N36254	Decal - "Calibrate/Fan" (VRT ONLY)	1
N49783	Decal - "Calibrate/Fan" (VRT ONLY)	1
N19029	Decal - "Rotation" (VRT Drive)	3
N19029	Decal - "Rotation" (Standard Drive)	1
N60303	Decal - "Hair Pin Location"	1 per transmission
N36256	Decal - "Quick Change Sprocket"	1 per transmission
N36257	Decal - "Meter Shaft Sprocket"	1 per transmission
N42291	Decal - "Auger Position"	1
N36453	Decal - "Fan/Auger"	1
N50875	Decal - Conveyor - Lock/Unlock - Raise/Lower	1
N36443	Decal - "Lever Position"	1
N36258	Decal - Caution - "Secure Auger"	1
N19033	Decal - Danger - "Electrocution Hazard"	1
N19034	Decal - Danger - "Rotating Flighting Hazard"	1
C25809	Decal - "Grease 50 Hours"	2 per transmission
C25810	Decal - "Grease 100 Hours"	2
N37492	Decal - "Open/Closed" - Plenum	2
N55695	Decal - Wheel Torque Chart	1
N34476	Reflector - Red	4
N34477	Reflector - Yellow	8
N34478	Reflector - Orange	4
N34475	SMV Sign	1

The following pages provide basic Decal Location information, for more details contact Morris' Customer Service.

Safety

Safety Signs - Continued

Front

9650 Front

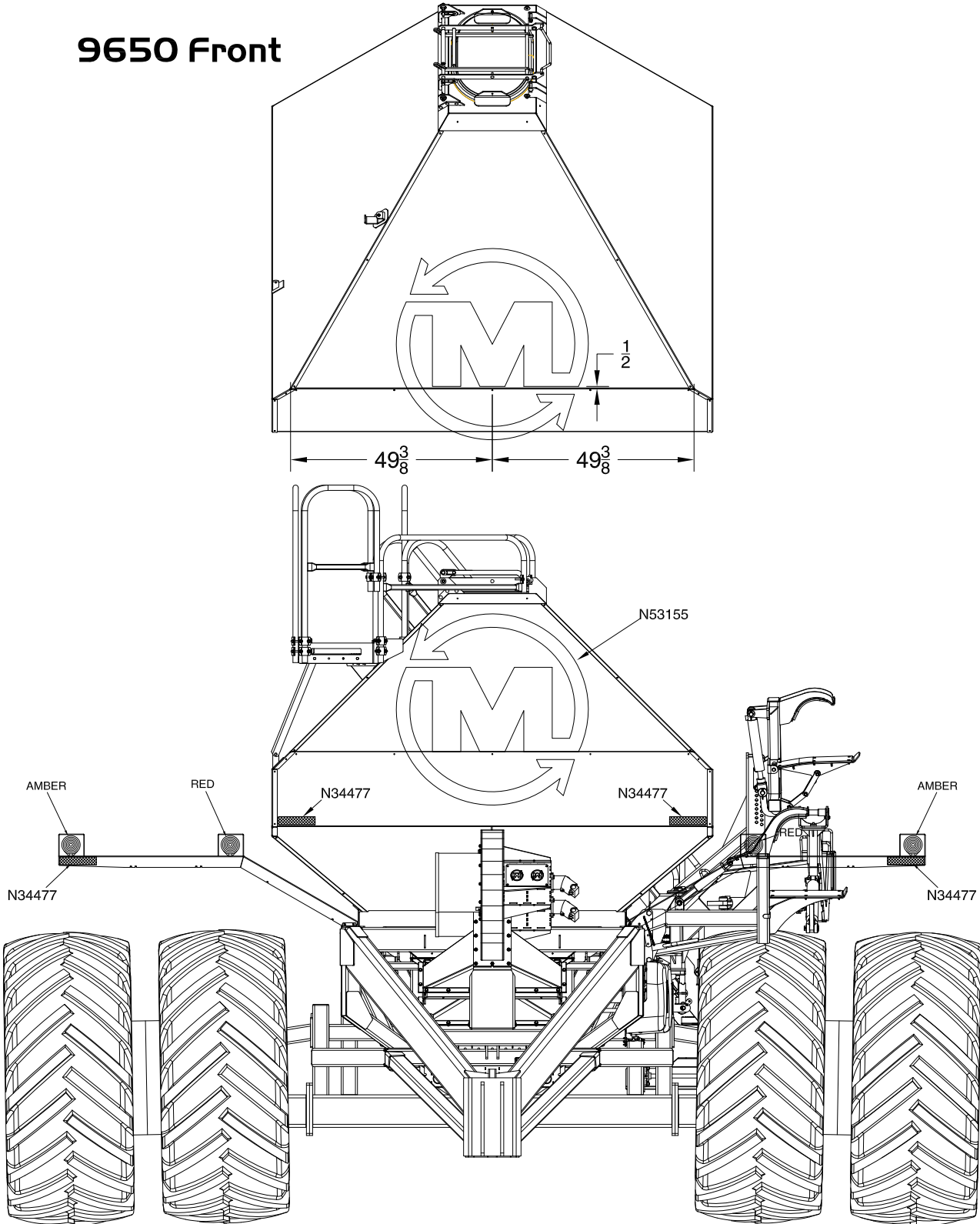

Safety Signs - Continued

Right Side - Tow Between

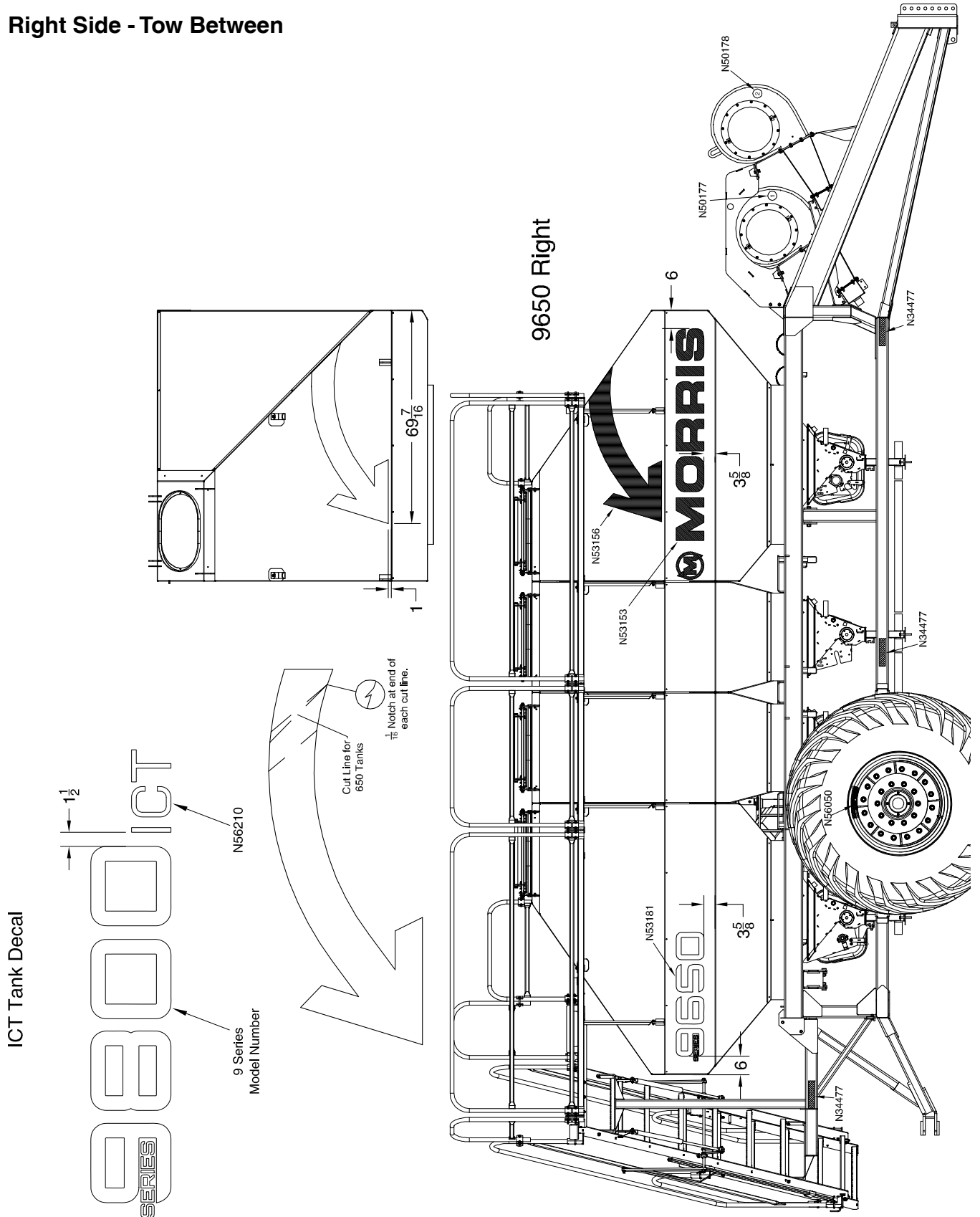

Safety Signs - Continued

Right Side - Tow Behind

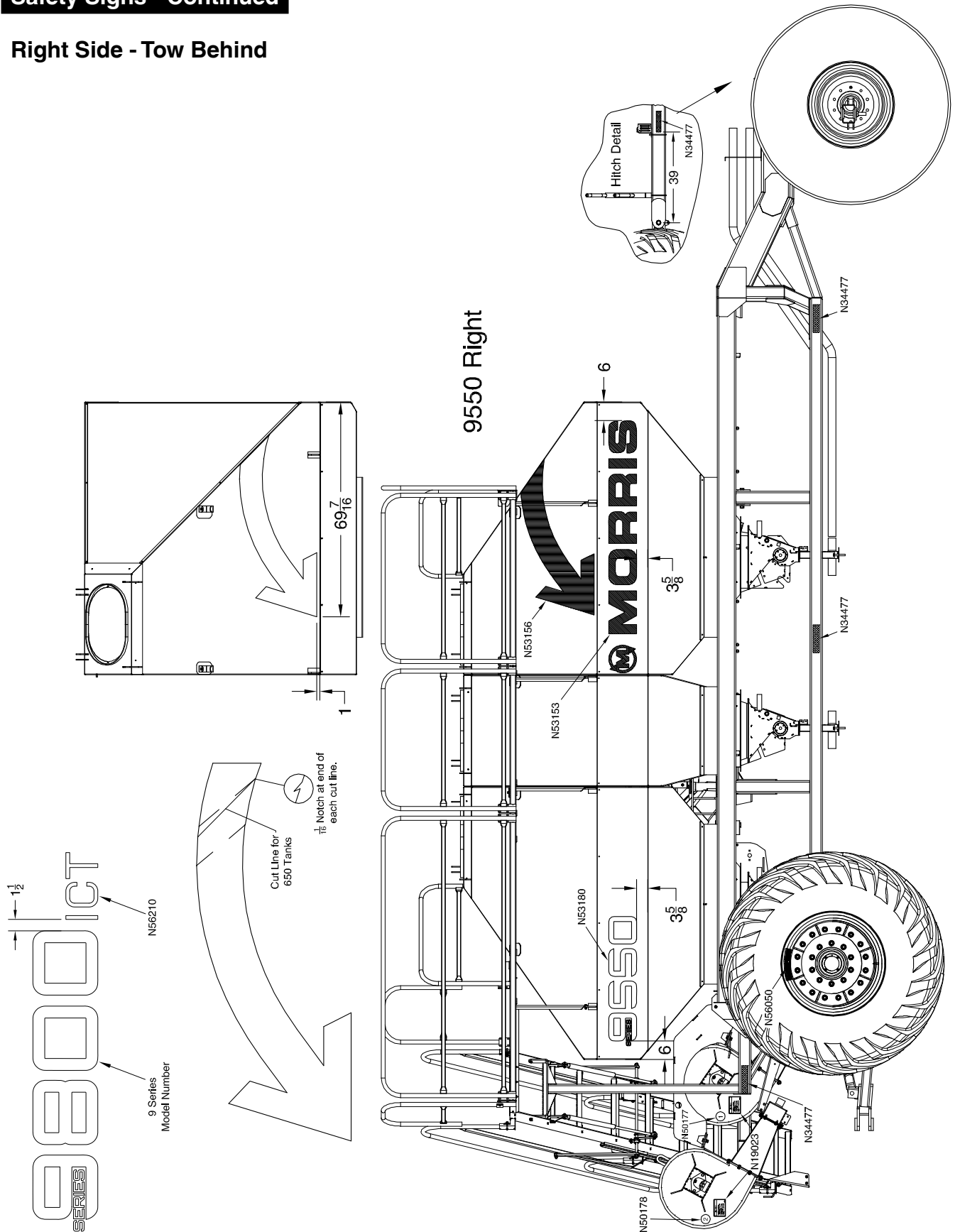

Safety

Safety Signs - Continued

Top

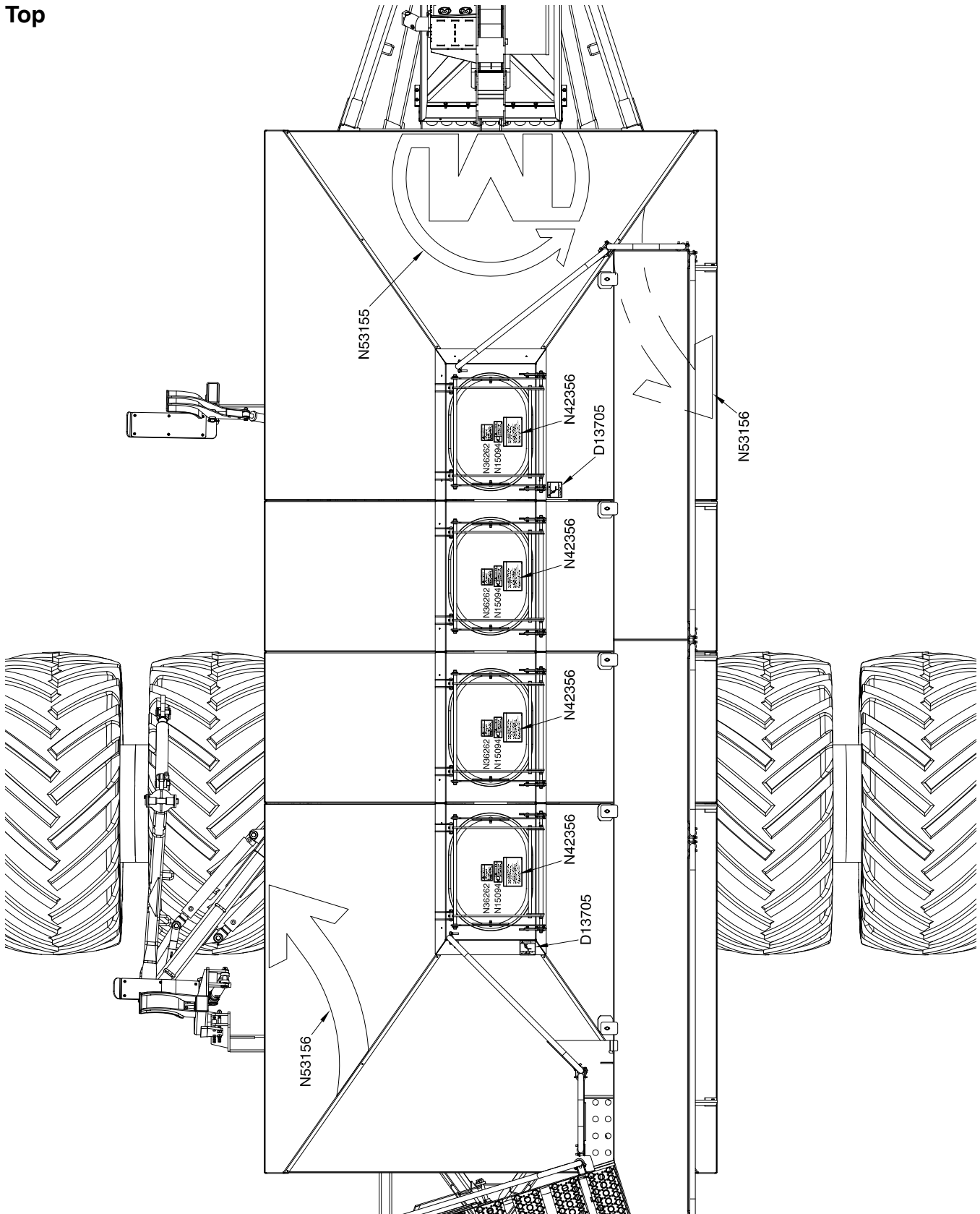

Safety Signs - Continued

ICT Meter Body

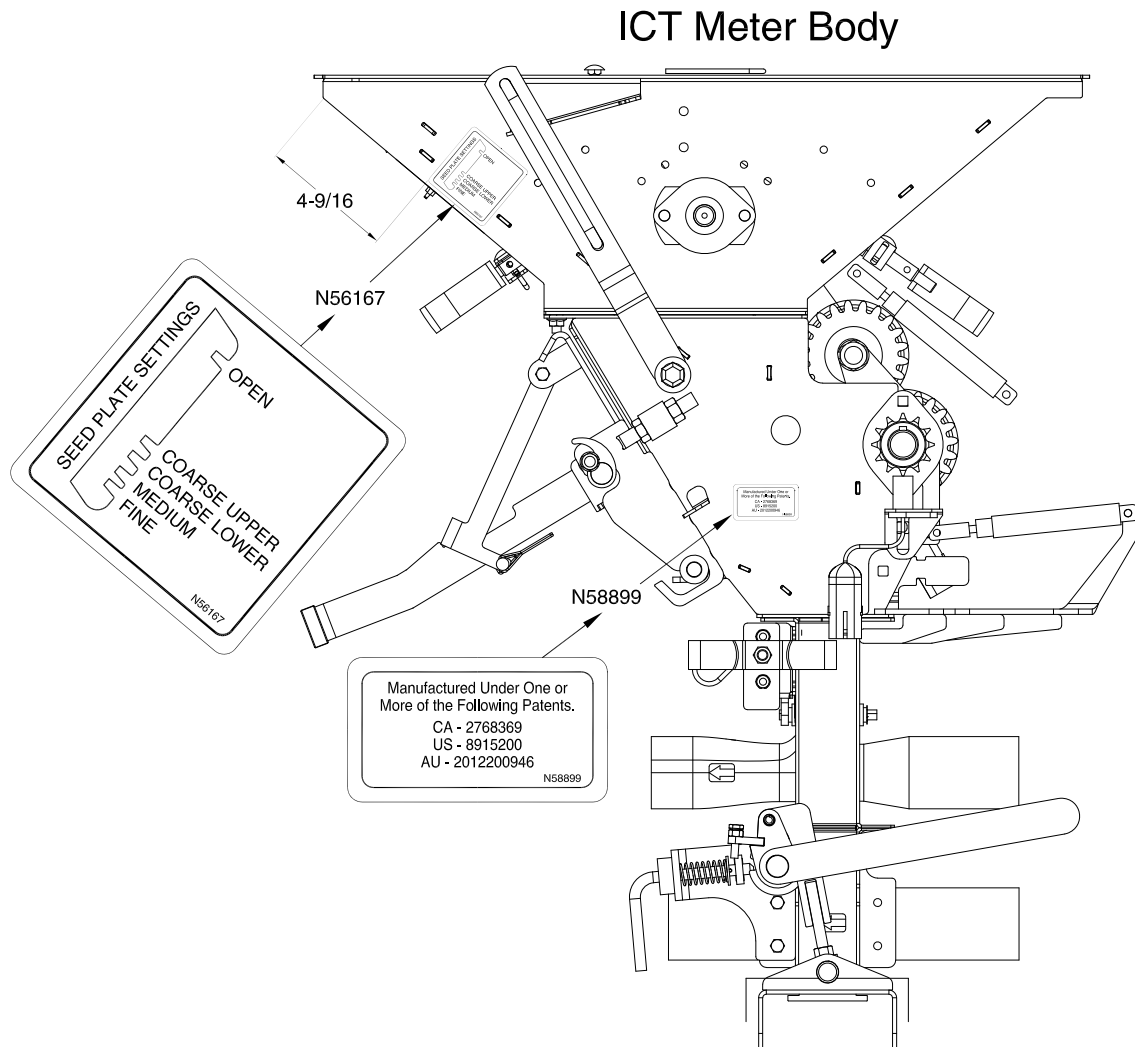

Safety

Lighting and Marking

MORRIS recommends the use of the correct lighting and marking to meet the ASAE standard for roadway travel. Be familiar with, and adhere to, local laws.

Amber warning and red taillights secured on the machine promote correct transportation of this implement.

Note: Always replace missing or damaged lights and/or connectors.

Amber warning and red taillights must be mounted to the rear of the implement and be visible from front and rear. The lights must be within 16 inches (41 cm) of the extremities of the machine and at least 39 inches (99 cm) but not over 10 feet (3 m) above ground level.

Note: Always replace missing or damaged front, side, rear reflectors and SMV emblem.



Tillage Unit

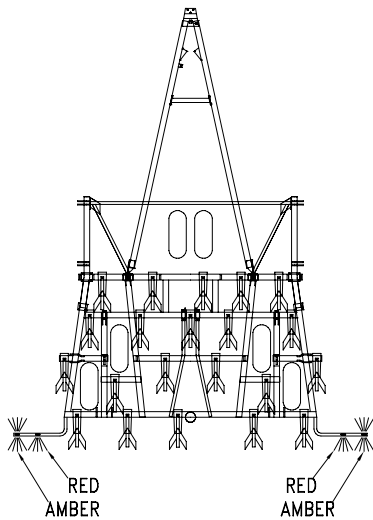

**Seeding Unit
Tow Between**

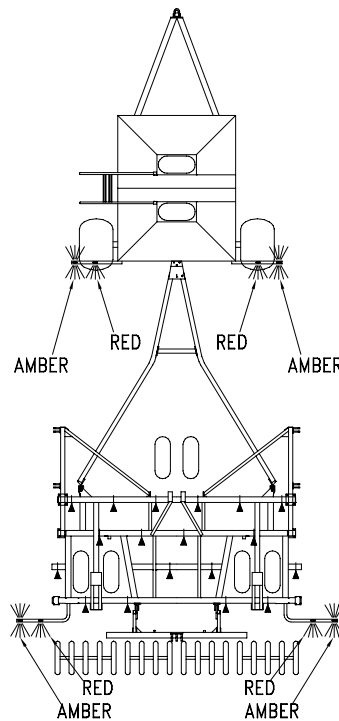

**Seeding Unit
Tow Behind**

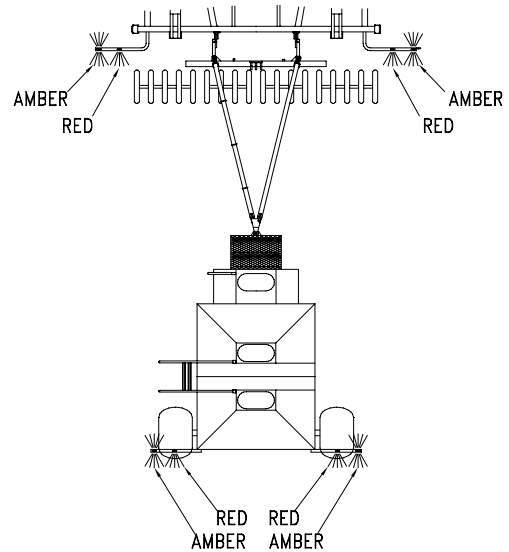

Lighting and Marking - Continued

**Seeding Unit - Tow Between
with Packer Bar**

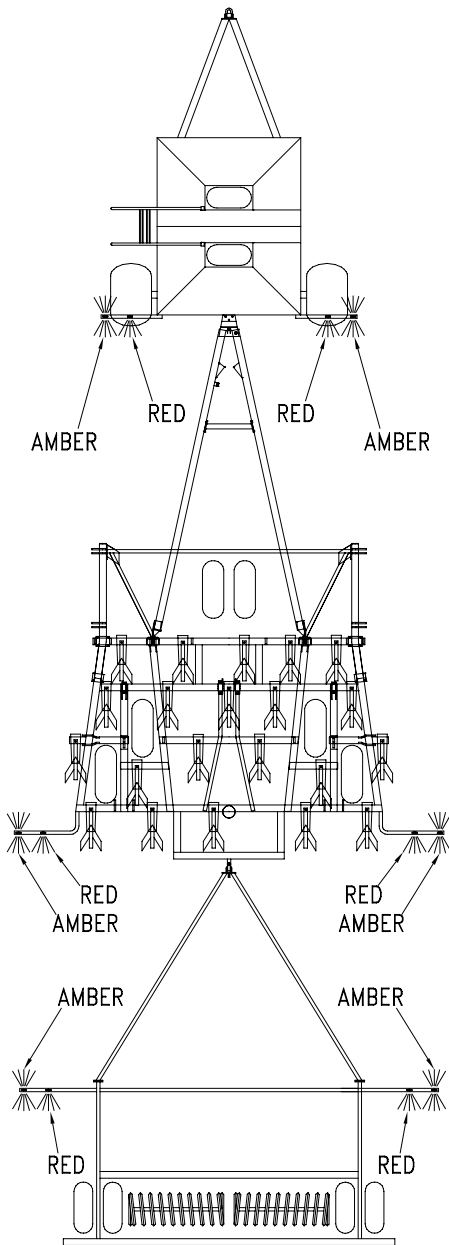

**Seeding Unit - Tow Behind
with Packer Bar**

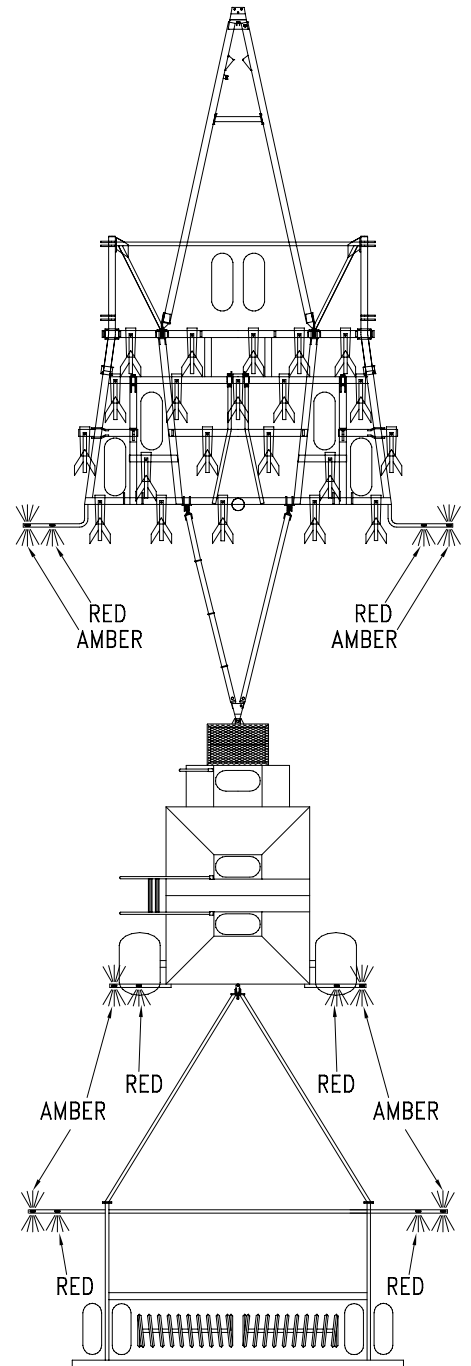

Safety

Conveyor Safety

General

- As the owner and/or operator it is your responsibility to know what requirements, hazards and precautions exist, and to inform all personnel associated with the equipment or are in the area.
- Avoid any alteration to the equipment. Such alterations may produce a very dangerous situation, where serious injury or death may occur.
- Untrained operators subject themselves and other to serious injury or death. NEVER ALLOW untrained personnel to operate this equipment.
- Keep children and other unqualified personnel out of the working area at all times.
- NEVER start equipment until ALL persons are clear of the work area.
- Be sure ALL operators are adequately rested and prepared to perform all functions of operating this equipment.
- Keep hair, loose clothing, and shoestrings away from rotating and moving parts. Never wear loose fitting clothing when working around conveyors.
- NEVER allow anyone inside a bin, truck, or wagon which is being unloaded by a conveyor. Flowing grain can trap and suffocate in seconds.
- Keep hands and feet away from the conveyor intake and other moving parts.
- NEVER attempt to assist machinery operation or to remove trash from the equipment while in operation.
- Keep the area around intake free of obstacles that might trip workers.
- Components of this equipment have sharp edges which can scrape and/or cut an operator.
- A moving conveyor can sever an operator's limb or even kill.
- Always keep all shields and guards in place during operation.



Conveyor Safety - Continued

Safety Signs

The Safety Decals listed below are included with the conveyor, the following pages show the location of the decals on the conveyor. Inspect all decals and replace any that are worn, illegible, or missing. Contact your dealer or the factory to order replacement decals.



KS-0008

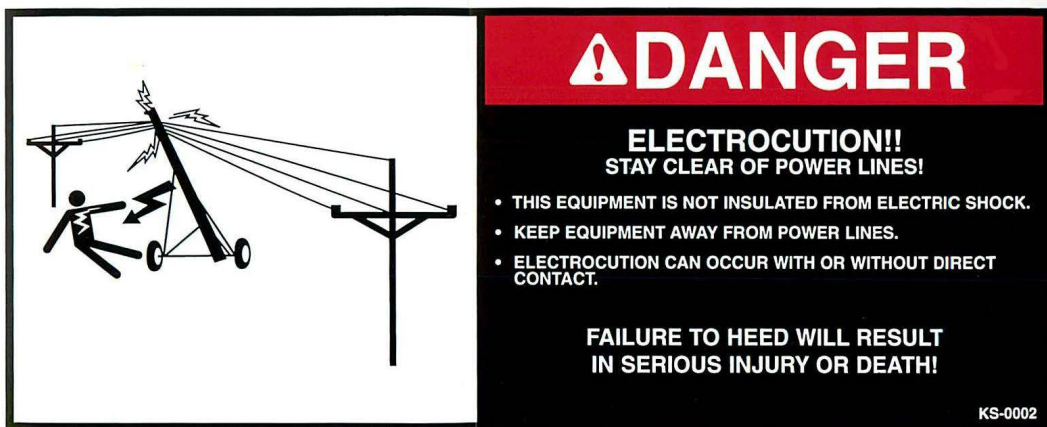

KS-0002

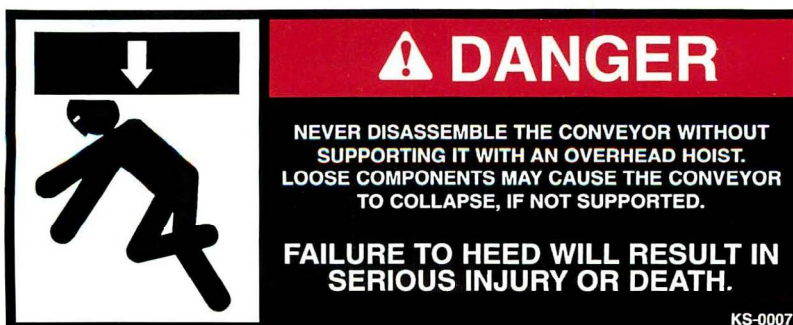

KS-0007

Safety

Conveyor Safety - Continued

Safety Signs - Continued

⚠ DANGER

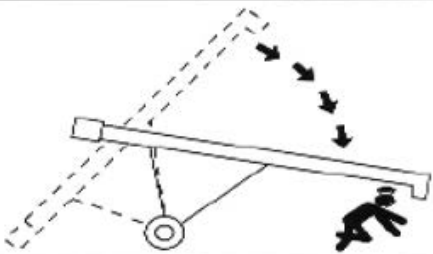

FALLING CONVEYOR CAN CRUSH OR KILL!

ALWAYS SECURE INTAKE END SO THAT THE CONVEYOR CANNOT FALL.

EMPTY THE CONVEYOR BEFORE ATTEMPTING TO TRANSPORT IT.

NEVER PUSH THE UNDERCARRIAGE. ALWAYS USE PROPER TRANSPORTING METHODS.

USE CAUTION WHEN LIFTING THE INTAKE END. NEVER LIFT HIGHER THAN THE VEHICLE TOW BAR. DO NOT RELEASE UNTIL CONVEYOR IS SECURELY ATTACHED TO THE TOW BAR OR ON THE GROUND.

LOWER THE CONVEYOR FOR TRANSPORTING IMMEDIATELY AFTER MOVING IT AWAY FROM THE STORAGE BIN.

FAILURE TO HEED WILL RESULT IN SERIOUS INJURY OR DEATH!

KS-0005



⚠ CAUTION

1. READ AND UNDERSTAND THE INSTALLATION & OPERATION MANUAL AND ALL SAFETY INSTRUCTIONS BEFORE OPERATING EQUIPMENT.
2. DO NOT OPERATE WHILE UNDER THE INFLUENCE OF DRUGS OR ALCOHOL.
3. DO NOT OPERATE UNLESS ALL SAFETY EQUIPMENT, SWITCHES, GUARDS AND SHIELDS ARE SECURELY IN PLACE AND OPERATIONAL.
4. BE SURE EVERYONE IS CLEAR OF THE EQUIPMENT BEFORE ATTEMPTING TO OPERATE OR MOVING THE MACHINE.
5. ALLOW ONLY TRAINED PERSONNEL IN THE OPERATING AREA.
6. KEEP HANDS, FEET, HAIR AND CLOTHING AWAY FROM MOVING PARTS.
7. DISCONNECT AND LOCKOUT POWER BEFORE ADJUSTING OR SERVICING.
8. ELECTRICAL WIRING OR SERVICE WORK MUST BE PERFORMED BY A QUALIFIED ELECTRICIAN. IT MUST MEET ALL STATE AND LOCAL ELECTRICAL CODES.
9. EMPTY CONVEYOR AND LOWER TO TRANSPORT POSITION BEFORE TRANSPORTING.
10. MAKE CERTAIN ALL ELECTRIC MOTORS ARE GROUNDED.
11. NEVER MOVE MACHINE MANUALLY. ALWAYS USE A TOWING VEHICLE.
12. KEEP CHILDREN AWAY FROM THE WORK AREA AT ALL TIMES.

KS-0001

Conveyor Safety - Continued

Safety Signs - Continued

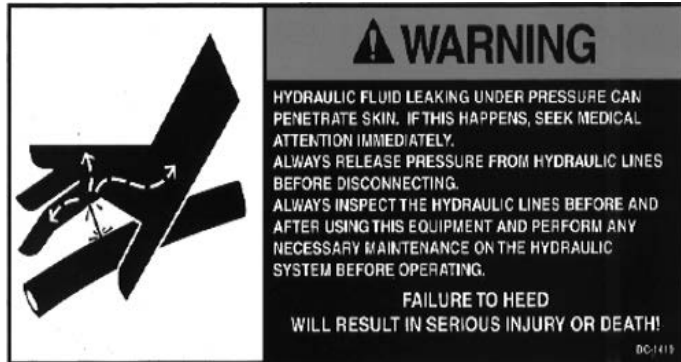

KS-1419



KS-0015

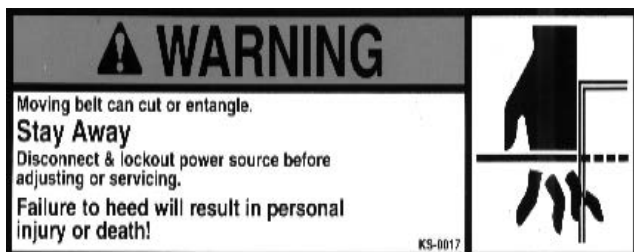

KS-0017

Safety

Conveyor Safety - Continued

Safety Signs - Continued



KS-0006



KS-0016



Section 2: Specifications

Section Contents

9365, 9450 and 9535 - Tow Behind.....	2-2
9365 and 9450 - Tow Between.....	2-3
9445, 9550 and 9650 - Tow Behind.....	2-4
9445, 9550 and 9650 - Tow Between.....	2-5
9555, 9680 and 9800 - Tow Behind.....	2-6
9555, 9680 and 9800 - Tow Between.....	2-7
91000 - Tow Behind.....	2-8

Specifications

9365, 9450 and 9535 - Tow Behind Specifications and Options

Model	9365	9450	9535
Configuration	Tow Behind	Tow Behind	Tow Behind
Length (Hitch pin to end of Auger) (Hitch Removed)	34' 6" (10.52 m)	34' 6" (10.52 m)	36' 10" (11.15 m) 30' 10" (9.40 m)
Height - Rails up	15' 2" (4.623 m)	15' 2" (4.623 m)	15' 2" (4.623 m)
Height - Rails Lowered	14' 2" (4.318 m)	14' 2" (4.318 m)	14' 2" (4.318 m)
Width	13' 7" (4.14 m)	13' 7" (4.14 m)	13' 7" (4.14 m)
- Single Axle - 800/65 R32	13' 10" (4.22 m)	13' 10" (4.22 m)	13' 10" (4.22 m)
- Single Axle - 900/65 R32	15' 11" (4.81 m)	15' 11" (4.81 m)	15' 11" (4.81 m)
- Dual Axle - 520/85 R38	20' (6.10 m)	20' (6.10 m)	20' (6.10 m)
- Dual Axle - 800/65 R32			
Weight (Hydraulic Drive)	10900 lbs (4944 kg)	11900 lbs (5398 kg)	13000 lbs (5897 kg)
Safety Lights	Standard	Standard	Standard
Safety Chain	Standard	Standard	Standard
Tank Capacity	N/A	182 bu (6414 l)	182 bu (6414 l)
- Tank 1	N/A	N/A	86 bu (3030 l)
- Tank 2	182 bu (6414 l)	86 bu (3030 l)	86 bu (3030 l)
- Tank 3	182 bu (6414 l)	182 bu (6414 l)	182 bu (6414 l)
- Tank 4	364 bu (12828 l)	450 bu (15858 l)	536 bu (18888 l)
- Total			
Tank Screens	Standard		
Fan Impeller Diameter	17" (43 cm) - Up to 5,000 r.p.m.		
Hydraulic Drive - piston type orbit motor (Closed Centre or Closed Centre Load Sensing systems required) Hydraulic requirements for Air Cart only at Rated Fan Speed.	16cc - 21 U.S. gal./min. (80 l/min) at 2,750 p.s.i. (18,960 kpa) Dual Fans require 42 U.S. gal./min. (160 l/min) VRT requires an additional 6 U.S. gal/min (23 l/min)		
Loading Auger	Standard (10" Dia) (25.4 cm Dia) Optional - extended hopper on hydraulic assisted auger		
Loading Conveyor	Optional (16") (40.6 cm) x 23 ft long		
Tires	<ul style="list-style-type: none"> - Off-Set Dual Axle (Front) - Standard on 9365 and 9450 - N/A for 9535 - Quad Steer Axle (Front) - Standard on 9535 - Optional on 9365 and 9450 - Rear - Standard on 9365 and 9450 - N/A for 9535 - Rear - Standard on 9535 - Optional on 9365 and 9450 - Rear - Optional on 9365 and 9450 - Rear - Optional on 9535 		
	2) 500/70 R24 Lug Distance Center-Center Inner 40" (102 cm)		
	(2) 28LR26 Lug Distance Center-Center Inner 138" (351 cm)		
	(2) 800/65R32 - LI 172 Lug Distance Center-Center 128" (325 cm)		
	(2) 900/65R32 - LI 172 Lug Distance Center-Center 132" (335 cm)		
	Duals - (4) 520/85R38 Lug Distance Center-Center Inner 119" (302 cm) Distance Center-Center Outer 171" (434 cm)		
	Duals - (4) 800/65R32 - LI 172 Lug Distance Center-Center Inner 132" (335 cm) Distance Center-Center Outer 208" (516 cm)		
Metering	<ul style="list-style-type: none"> - Ground Driven - Variable Rate (VRT) - GPS Compatible VRT - ICT (Input Control Technology) 		
	Standard		
	Optional		
	Optional		
	Optional with VRT		
Meter Shut Off	Electric		
Number Secondary Runs - Single Shoot	21 to 99 (ICT 21 - 90)		
Number Secondary Runs - Double Shoot	42 to 198 (ICT 42 - 180)		
Primary Hose - Diameter	2 1/2" (6.4 cm)		
Secondary Hose - Diameter	Standard - 15/16" (2.4 cm) Optional - 1 1/8" (2.8 cm)		
Frame - Trussed	4" x 6" (10 cm x 15.2cm) tubing by 4" x 4" (10 cm x 10 cm) tubing		
Easy Clean Out System	Standard		
Meter Drive Options - Second Clutch (For spot fertilizing on the go)	Standard		
Monitor (Shaft Motion (3), Bin Level (3), Fan Speed, Acre Tally, Ground Speed)	Standard Optional Seed Flow		
Work Switch (Mounted to Seeding Machine)	Optional		
Rear Tow Hitch	Optional (Max 15,000 lb Draft Load) (Max 6,818 kg Draft Load)		
Hitch Stand	Optional - N/A for 9535		

Specifications

9365 and 9450 - Tow Between Specifications and Options

Model	9365	9450
Configuration	Tow Between	Tow Between
Length (with auger)	31' 5" (9.58 m)	31' 5" (9.58 m)
Height - Rails up	15' 2" (4.623 m)	15' 2" (4.623 m)
Height - Rails Lowered	14' 2" (4.318 m)	14' 2" (4.318 m)
Width - Single Axle - 800/65 R32 - Single Axle - 900/65 R32 - Dual Axle - 520/85 R38 - Dual Axle - 800/65 R32	13' 7" (4.14 m)	13' 7" (4.14 m)
	13' 10" (4.22 m)	13' 10" (4.22 m)
	15' 11" (4.81 m)	15' 11" (4.81 m)
	20' (6.10 m)	20' (6.10 m)
Weight (Hydraulic Drive)	14100 lbs (6396 kg)	15100 lbs (6849 kg)
Safety Lights	Standard	Standard
Safety Chain	Standard	Standard
Tank Capacity - Tank 1 - Tank 2 - Tank 3 - Tank 4 - Total	N/A	182 bu (6414 l)
	N/A	N/A
	182 bu (6414 l)	86 bu (3030 l)
	182 bu (6414 l)	182 bu (6414 l)
	364 bu (12828 l)	450 bu (15858 l)
Tank Screens	Standard	
Fan Impeller Diameter	17" (43 cm) - Up to 5,000 r.p.m.	
Hydraulic Drive - piston type orbit motor (Closed Centre or Closed Centre Load Sensing systems required) Hydraulic requirements for Air Cart only at Rated Fan Speed.	16cc - 21 U.S. gal./min. (80 l/min) at 2,750 p.s.i. (18,960 kpa) Dual Fans require 42 U.S. gal./min. (160 l/min) VRT requires an additional 6 U.S. gal/min (23 l/min)	
Loading Auger	Standard (10" Dia) (25.4 cm Dia) Optional - extended hopper on hydraulic assisted auger	
Loading Conveyor	Optional (16") (40.6 cm) x 23 ft long	
Tires - Standard (Rear) - Optional (Rear) - Optional (Rear)	(2) 800/65R32 - LI 172 Lug Distance Center-Center 128" (325 cm)	
	(2) 900/65R32 - LI 172 Lug Distance Center-Center 132" (335 cm)	
	Duals - (4) 800/65R32 - LI 172 Lug Distance Center-Center Inner 132" (335 cm) Distance Center-Center Outer 208" (516 cm)	
Metering - Ground Driven - Variable Rate (VRT) - GPS Compatible VRT - ICT (Input Control Technology)	Standard	
	Optional	
	Optional	
	Optional with VRT	
Meter Shut Off	Electric	
Number Secondary Runs - Single Shoot	21 to 99 (ICT 21 - 90)	
Number Secondary Runs - Double Shoot	42 to 198 (ICT 42 - 180)	
Primary Hose - Diameter	2 1/2" (6.4 cm)	
Secondary Hose - Diameter	Standard - 1 5/16" (2.4 cm) Optional - 1 1/8" (2.8 cm)	
Frame - Trussed	4" x 6" (10 cm x 15.2cm) tubing by 4" x 4" (10 cm x 10 cm) tubing	
Easy Clean Out System	Standard	
Meter Drive Options - Second Clutch (For spot fertilizing on the go)	Standard	
Monitor (Shaft Motion (3), Bin Level (3), Fan Speed, Acre Tally, Ground Speed)	Standard Optional Seed Flow	
Work Switch (Mounted to Seeding Machine)	Optional	
Rear Tow Hitch	Standard (Max 26,000 lb Draft Load) (Max 11,818 kg Draft Load)	
Hitch Jack - Hydraulic	Optional	
Work Lights - LED	Optional	
Hitch Clevis	Standard - Category 4	Optional - Category 5

Specifications

9445, 9550 and 9650 - Tow Behind Specifications and Options

Model	9445	9550	9650
Configuration	Tow Behind	Tow Behind	Tow Behind
Length (Hitch pin to Dual Fan) (Hitch Removed)	39' 3" (11.96 m) 36' 7" (11.15 m)	39' 3" (11.96 m) 36' 7" (11.15 m)	39' 3" (11.96 m) 36' 7" (11.15 m)
Height - Rails up	15' 2" (4.623 m)	15' 2" (4.623 m)	15' 2" (4.623 m)
Height - Rails Lowered	14' 2" (4.318 m)	14' 2" (4.318 m)	14' 2" (4.318 m)
Width - Single Axle - 900/65 R32	13' 10" (4.22 m)	13' 10" (4.22 m)	13' 10" (4.22 m)
- Dual Axle - 520/85 R38	15' 11" (4.81 m)	15' 11" (4.81 m)	15' 11" (4.81 m)
- Dual Axle - 800/65 R32	20' (6.10 m)	20' (6.10 m)	20' (6.10 m)
Weight (Hydraulic Drive)	17,300 lbs (7,847 kg)	18,000 lbs (8,165 kg)	18,700 lbs (8,482 kg)
Safety Lights	Standard	Standard	Standard
Safety Chain	Standard	Standard	Standard
Tank Capacity - Tank 1	N/A	221 bu (7788 l)	221 bu (7788 l)
- Tank 2	N/A	N/A	107 bu (3772 l)
- Tank 3	221 bu (7788 l)	107 bu (3772 l)	107 bu (3772 l)
- Tank 4	221 bu (7788 l)	221 bu (7788 l)	221 bu (7788 l)
- Total	442 bu (15,576 l)	549 bu (19,348 l)	656 bu (23,120 l)
Tank Screens	Standard		
Fan Impeller Diameter	17" (43 cm) - Up to 5,000 r.p.m.		
Hydraulic Drive - piston type orbit motor (Closed Centre or Closed Centre Load Sensing systems required) Hydraulic requirements for Air Cart only at Rated Fan Speed.	16cc 21 U.S. gal./min. (80 l/min) at 2,750 p.s.i. (18,960 kpa) Dual Fans require 42 U.S. gal./min. (160 l/min) VRT requires an additional 6 U.S. gal/min (23 l/min)		
Loading Auger	Standard (10" Dia) (25.4 cm Dia) Optional - extended hopper on hydraulic assisted auger		
Loading Conveyor	Optional (16") (40.6 cm) x 23 ft long		
Tires - Quad Steer (Front)	(2) 28LR26 Lug Distance Center-Center Inner 138" (351 cm)		
- Standard (Rear)	Single - (2) 900/65R32 - LI 172 Lug Distance Center-Center Inner 140" (356 cm)		
- Optional (Rear)	Duals - (4) 800/65R32 - LI 172 Lug Distance Center-Center Inner 140" (356 cm) Distance Center-Center Outer 216" (549 cm)		
- Optional (Rear)	Single - (2) 710/70R38 - DT - 824 TL Lug Distance Center-Center 118" (300 cm)		
Metering - Ground Driven	Standard		
- Variable Rate (VRT)	Optional		
- GPS Compatible VRT	Optional		
- ICT (Input Control Technology)	Optional with VRT		
Meter Shut Off	Electric		
Number Secondary Runs - Single Shoot	21 to 99 (ICT 21 - 90)		
Number Secondary Runs - Double Shoot	42 to 198 (ICT 42 - 180)		
Primary Hose - Diameter	2 1/2" (6.4 cm)		
Secondary Hose - Diameter	Standard - 15/16" (2.4 cm) Optional - 1 1/8" (2.8 cm)		
Frame - Trussed	4" x 6" (10 cm x 15.2cm) tubing by 4" x 4" (10 cm x 10 cm) tubing		
Easy Clean Out System	Standard		
Meter Drive Options - Second Clutch (For spot fertilizing on the go)	Standard		
Monitor (Shaft Motion (3), Bin Level (3), Fan Speed, Acre Tally, Ground Speed)	Standard Optional Seed Flow		
Work Switch (Mounted to Seeding Machine)	Optional		
Rear Tow Hitch	Standard (Max 26,000 lb Draft Load) (Max 11,818 kg Draft Load)		

Specifications

9445, 9550 and 9650 - Tow Between Specifications and Options

Model	9445	9550	9650
Configuration	Tow Between	Tow Between	Tow Between
Length (with auger)	34' 6" (10.52 m)	34' 6" (10.52 m)	34' 6" (10.52 m)
Height - Rails up	15' 2" (4.623 m)	15' 2" (4.623 m)	15' 2" (4.623 m)
Height - Rails Lowered	14' 2" (4.318 m)	14' 2" (4.318 m)	14' 2" (4.318 m)
Width - Dual Axle	20' (6.10 m)	20' (6.10 m)	20' (6.10 m)
Weight (Hydraulic Drive)	20,000 lbs (9072 kg)	20700 lbs (9389 kg)	21400 lbs (9707 kg)
Safety Lights	Standard	Standard	Standard
Safety Chain	Standard	Standard	Standard
Tank Capacity - Tank 1	N/A	221 bu (7788 l)	221 bu (7788 l)
- Tank 2	N/A	N/A	107 bu (3772 l)
- Tank 3	221 bu (7788 l)	107 bu (3772 l)	107 bu (3772 l)
- Tank 4	221 bu (7788 l)	221 bu (7788 l)	221 bu (7788 l)
- Total	442 bu (15,576 l)	549 bu (19348 l)	656 bu (23,120 l)
Tank Screens	Standard		
Fan Impeller Diameter	17" (43 cm) - Up to 5,000 r.p.m.		
Hydraulic Drive - piston type orbit motor (Closed Centre or Closed Centre Load Sensing systems required) Hydraulic requirements for Air Cart only at Rated Fan Speed.	16cc 21 U.S. gal./min. (80 l/min) at 2,750 p.s.i. (18,960 kpa) Dual Fans require 42 U.S. gal./min. (160 l/min) VRT requires an additional 6 U.S. gal/min (23 l/min)		
Loading Auger	Standard (10" Dia) (25.4 cm Dia) Optional - extended hopper on hydraulic assisted auger		
Loading Conveyor	Optional (16") (40.6 cm) x 23 ft long		
Tires - Standard (Rear)	Duals - (4) 800/65R32 - LI 172 Lug Distance Center-Center Inner 132" (335 cm) Distance Center-Center Outer 208" (516 cm)		
Metering - Ground Driven	Standard		
- Variable Rate (VRT)	Optional		
- GPS Compatible VRT	Optional		
- ICT (Input Control Technology)	Optional with VRT		
Meter Shut Off	Electric		
Number Secondary Runs - Single Shoot	21 to 99 (ICT 21 - 90)		
Number Secondary Runs - Double Shoot	42 to 198 (ICT 42 - 180)		
Primary Hose - Diameter	2 1/2" (6.4 cm)		
Secondary Hose - Diameter	Standard - 15/16" (2.4 cm) Optional - 1 1/8" (2.8 cm)		
Frame - Trussed	4" x 6" (10 cm x 15.2cm) tubing by 4" x 4" (10 cm x 10 cm) tubing		
Easy Clean Out System	Standard		
Meter Drive Options - Second Clutch (For spot fertilizing on the go)	Standard		
Monitor (Shaft Motion (3), Bin Level (3), Fan Speed, Acre Tally, Ground Speed)	Standard Optional Seed Flow		
Work Switch (Mounted to Seeding Machine)	Optional		
Rear Tow Hitch	Standard (Max 26,000 lb Draft Load) (Max 11,818 kg Draft Load)		
Hitch Jack - Hydraulic	Standard		
Work Lights - LED	Optional		
Hitch Clevis	Standard - Category 4 Optional - Category 5		

Specifications

9555, 9680 and 9800 - Tow Behind Specifications and Options

Model	9555	9680	9800
Configuration	Tow Behind	Tow Behind	Tow Behind
Length (Hitch pin to Dual Fan) (Hitch Removed)	43' 6" (13.28 m) 34' 6" (10.52 m)	43' 6" (13.28 m) 34' 6" (10.52 m)	43' 6" (13.28 m) 34' 6" (10.52 m)
Height - Rails up	15' 8" (4.77 m)	15' 8" (4.77 m)	15' 8" (4.77 m)
Height - Rails Lowered	14' 8" (4.47 m)	14' 8" (4.47 m)	14' 8" (4.47 m)
Width - Dual Axle - 800/65 R32 - Prior to 2016	20' 10" (6.35 m)	20' 10" (6.35 m)	20' 10" (6.35 m)
- Dual Axle - 800/70R38	22' 4" (6.81 m)	22' 4" (6.81 m)	22' 4" (6.81 m)
- Dual Axle - 850/80R38			
Weight (Hydraulic Drive)	27652 (12543 kg)	28946 (13130 kg)	30240 lbs (13720 kg)
Safety Lights	Standard	Standard	Standard
Safety Chain	Standard	Standard	Standard
Tank Capacity - Tank 1	265 bu (9339 l)	265 bu (9339 l)	265 bu (9339 l)
- Tank 2	N/A	N/A	133 bu (4700 l)
- Tank 3	N/A	133 bu (4700 l)	133 bu (4700 l)
- Tank 4	284 bu (10008 l)	284 bu (10008 l)	284 bu (10008 l)
- Total	549 bu (19347 l)	682 bu (24047 l)	815 bu (28747 l)
Tank Screens	Standard		
Fan Impeller Diameter	17" (43 cm) - Up to 5,000 r.p.m.		
Hydraulic Drive - piston type orbit motor (Closed Centre or Closed Centre Load Sensing systems required) Hydraulic requirements for Air Cart only at Rated Fan Speed.	16cc 21 U.S. gal./min. (80 l/min) at 2,750 p.s.i. (18,960 kpa) VRT requires an additional 6 U.S. gal/min (23 l/min)		
Loading Auger	Standard (10" Dia) (25.4 cm Dia) Optional - extended hopper on hydraulic assisted auger		
Loading Conveyor	Optional (16") (40.6 cm)		
Brakes - Rear	Standard - 22" (55.9 cm) Diameter Disc - 4 piston caliper		
Tires - Standard Quad Steer (Front) (Tow Behind only)	(2) 800/65 R32 - LI 172 Lug Distance Center-Center Inner 155" (393 cm)		
- Optional Quad Steer (Front) (Tow Behind only)	(2) 800/70R38 - LI 172 Lug Distance Center-Center Inner 155" (393 cm)		
- Standard (Rear)	Duals - (4) 800/70R38 - LI 172 Lug Distance Center-Center Inner 154" (391.2 cm) Distance Center-Center Outer 234" (594.4 cm)		
- Optional (Rear)	Duals - (4) 850/80R38 - LI 172 Lug Distance Center-Center Inner 154" (391.2 cm) Distance Center-Center Outer 234" (594.4 cm)		
Metering - Ground Driven	Standard		
- Variable Rate (VRT)	Optional		
- GPS Compatible VRT	Optional		
- ICT (Input Control Technology)	Optional with VRT		
Meter Shut Off	Electric		
Number Secondary Runs - Single Shoot	21 to 110 (ICT 21-100)		
Number Secondary Runs - Double Shoot	42 to 220 (ICT 42-200)		
Primary Hose - Diameter	2 1/2" (6.4 cm)		
Secondary Hose - Diameter	Standard - 15/16" (2.4 cm) Optional - 1 1/8" (2.8 cm)		
Frame - Trussed	4" x 10" (10 cm x 25.4cm) tubing by 4" x 4" (10 cm x 10 cm) tubing		
Easy Clean Out System	Standard		
Meter Drive Options - Second Clutch (For spot fertilizing on the go)	Standard		
Monitor (Shaft Motion (3), Bin Level (3), Fan Speed, Acre Tally, Ground Speed)	Standard Optional Seed Flow		
Work Switch (Mounted to Seeding Machine)	Optional		
Rear Tow Hitch	Standard (Max 26,000 lb Draft Load) (Max 11,818 kg Draft Load)		
Mechanical Acre Meter	Optional (Ground Drive Only)		

Specifications

9555, 9680 and 9800 - Tow Between Specifications and Options

Model	9555	9680	9800
Configuration	Tow Between	Tow Between	Tow Between
Length (Hitch pin to conveyor end)	35' 1" (10.69 m)	35' 1" (10.69 m)	35' 1" (10.69 m)
Height - Rails up	15' 8" (4.77 m)	15' 8" (4.77 m)	15' 8" (4.77 m)
Height - Rails Lowered	14' 8" (4.47 m)	14' 8" (4.47 m)	14' 8" (4.47 m)
Width - Dual Axle - 800/65 R32 - Prior to 2016	20' 10" (6.35 m)	20' 10" (6.35 m)	20' 10" (6.35 m)
- Dual Axle - 800/70R38	22' 4" (6.81 m)	22' 4" (6.81 m)	22' 4" (6.81 m)
- Dual Axle - 850/80R38			
Weight (Hydraulic Drive)	27152 lbs (12316 kg)	28446 (12903 kg)	29740 lbs (13490 kg)
Safety Lights	Standard	Standard	Standard
Safety Chain	Standard	Standard	Standard
Tank Capacity - Tank 1	265 bu (9339 l)	265 bu (9339 l)	265 bu (9339 l)
- Tank 2	N/A	N/A	133 bu (4700 l)
- Tank 3	N/A	133 bu (4700 l)	133 bu (4700 l)
- Tank 4	284 bu (10008 l)	284 bu (10008 l)	284 bu (10008 l)
- Total	549 bu (19347 l)	682 bu (24047 l)	815 bu (28747 l)
Tank Screens	Standard		
Fan Impeller Diameter	17" (43 cm) - Up to 5,000 r.p.m.		
Hydraulic Drive - piston type orbit motor (Closed Centre or Closed Centre Load Sensing systems required) Hydraulic requirements for Air Cart only at Rated Fan Speed.	16cc 21 U.S. gal./min. (80 l/min) at 2,750 p.s.i. (18,960 kpa) VRT requires an additional 6 U.S. gal/min (23 l/min)		
Loading Auger	Standard (10" Dia) (25.4 cm Dia) Optional - extended hopper on hydraulic assisted auger		
Loading Conveyor	Optional (16") (40.6 cm)		
Brakes - Rear	Standard - 22" (55.9 cm) Diameter Disc - 4 piston caliper		
Tires - Standard (Rear)	Duals - (4) 800/70R38 - LI 172 Lug Distance Center-Center Inner 154" (391.2 cm) Distance Center-Center Outer 234" (594.4 cm)		
- Optional (Rear)	Duals - (4) 850/80R38 - LI 172 Lug Distance Center-Center Inner 154" (391.2 cm) Distance Center-Center Outer 234" (594.4 cm)		
Metering - Ground Driven	Standard		
- Variable Rate (VRT)	Optional		
- GPS Compatible VRT	Optional		
- ICT (Input Control Technology)	Optional with VRT		
Meter Shut Off	Electric		
Number Secondary Runs - Single Shoot	21 to 110 (ICT 21-100)		
Number Secondary Runs - Double Shoot	42 to 220 (ICT 42-200)		
Primary Hose - Diameter	2 1/2" (6.4 cm)		
Secondary Hose - Diameter	Standard - 15/16" (2.4 cm) Optional - 1 1/8" (2.8 cm)		
Frame - Trussed	4" x 10" (10 cm x 25.4cm) tubing by 4" x 4" (10 cm x 10 cm) tubing		
Easy Clean Out System	Standard		
Meter Drive Options - Second Clutch (For spot fertilizing on the go)	Standard		
Monitor (Shaft Motion (3), Bin Level (3), Fan Speed, Acre Tally, Ground Speed)	Standard Optional Seed Flow		
Work Switch (Mounted to Seeding Machine)	Optional		
Rear Tow Hitch	Standard (Max 26,000 lb Draft Load) (Max 11,818 kg Draft Load)		
Mechanical Acre Meter	Optional (Ground Drive Only)		

Specifications

91000 - Tow Behind Specifications and Options

Model	91000
Configuration	Tow Behind
Length (Hitch pin to Dual Fan) (Hitch Removed)	43' 6" (13.28 m) 34' 6" (10.52 m)
Height - Rails up	16' 6" (5.03 m)
Height - Rails Lowered	15' 6" (4.73 m)
Width - Dual Axle - 800/70R38 - Dual Axle - 850/80R38	22' 4" (6.81 m)
Weight (Hydraulic Drive)	31240 lbs (14170 kg)
Safety Lights	Standard
Safety Chain	Standard
Tank Capacity - Tank 1	331 bu (11664 l)
- Tank 2	162 bu (5709 l)
- Tank 3	162 bu (5709 l)
- Tank 4	349 bu (12298 l)
- Total	1004 bu (35380 l)
Tank Screens	Standard
Fan Impeller Diameter	17" (43 cm) - Up to 5,000 r.p.m.
Hydraulic Drive - piston type orbit motor (Closed Centre or Closed Centre Load Sensing systems required) Hydraulic requirements for Air Cart only at Rated Fan Speed.	16cc 21 U.S. gal./min. (80 l/min) at 2,750 p.s.i. (18,960 kpa) VRT requires an additional 6 U.S. gal/min (23 l/min)
Loading Auger	Standard (12" Dia) (30.5 cm Dia) Optional - extended hopper on hydraulic assisted auger
Loading Conveyor	Optional (16") (40.6 cm) x 25 ft long
Tires - Standard Quad Steer (Front) (Tow Behind only)	(2) 800/65R32 - LI 172 Lug Distance Center-Center Inner 155" (393 cm)
- Optional Quad Steer (Front) (Tow Behind only)	(2) 800/70R38 - LI 172 Lug Distance Center-Center Inner 155" (393 cm)
- Standard (Rear)	Duals - (4) 800/70R38 - LI 172 Lug Distance Center-Center Inner 154" (391.2 cm) Distance Center-Center Outer 234" (594.4 cm)
- Optional (Rear)	Duals - (4) 850/80R38 - LI 172 Lug Distance Center-Center Inner 154" (391.2 cm) Distance Center-Center Outer 234" (594.4 cm)
Metering - Ground Driven	Standard
- Variable Rate (VRT)	Optional
- GPS Compatible VRT	Optional
- ICT (Input Control Technology)	Optional with VRT
Meter Shut Off	Electric
Number Secondary Runs - Single Shoot	21 to 110 (ICT 21-100)
Number Secondary Runs - Double Shoot	42 to 220 (ICT 42 - 200)
Primary Hose - Diameter	2 1/2" (6.4 cm)
Secondary Hose - Diameter	Standard - 1 5/16" (2.4 cm) Optional - 1 1/8" (2.8 cm)
Frame - Trussed	4" x 10" (10 cm x 25.4cm) tubing by 4" x 4" (10 cm x 10 cm) tubing
Easy Clean Out System	Standard
Meter Drive Options - Second Clutch (For spot fertilizing on the go)	Standard
Monitor (Shaft Motion (3), Bin Level (3), Fan Speed, Acre Tally, Ground Speed)	Standard Optional Seed Flow
Work Switch (Mounted to Seeding Machine)	Optional
Rear Tow Hitch	Standard (Max 26,000 lb Draft Load) (Max 11,818 kg Draft Load)

Section 3: Checklist

Section Contents

Manuals	3-2
Parts Manual	3-2
Assembly Manual	3-2
Checklist	3-3

Checklist

SAFETY-ALERT SYMBOL



Watch for this symbol. It identifies potential hazards to health or personal safety. It points out safety precautions. It means:

**ATTENTION - BE ALERT.
Your safety is involved.**

Manuals

Note: Pre-Delivery Inspection Form must be completed and submitted to Morris Equipment within 30 days of delivery date.

Warranty Void if Not Registered

Parts Manual Order Part Number N53349

Assembly Manual Order Part Number N56601

Checklist

Please read the Operator's Manual carefully and become a "SAFE" operator.

Adopt a good lubrication and maintenance program.

OWNER REFERENCE

Model: _____

Serial No: _____

Dealer: _____

Town: _____ State: _____

Phone: _____

OWNER/OPERATOR _____

Date: _____

General

___ Check if assembled correctly.

___ Proper chain tension.

___ Check hose connections.

___ Ensure cleanout door and tank lid are connected correctly.

Lubrication - Grease

___ Metering Drive

___ Axle Pivots

___ Auger Pivots

Lubrication - Oil

___ Drive chains

Tire Pressure

___ See Maintenance, Section 7.

Transport

___ Lock-up pins must be in place.

___ Tighten wheel bolts.

___ Check hose connections.



TAKE SAFETY SERIOUSLY.

**DO NOT TAKE
NEEDLESS CHANCES!!**

Checklist

Notes

Section 4: Introduction

Section Contents

Introduction.....	4-2
Standard Features.....	4-3
Hydraulic Auger.....	4-3
Full Bin Indicator.....	4-4
Options.....	4-4
Hydraulic Conveyor.....	4-4
Digi-Star Weigh Scale.....	4-4
Dual Fan.....	4-5

Introduction

Introduction

This Operator's Manual has been carefully prepared to provide the necessary information regarding the operation and adjustments, so that you may obtain maximum service and satisfaction from your new MORRIS 9 Series Air Cart.

To protect your investment, study your manual before starting or operating in the field. Learn how to operate and service your 9 Series Air Cart correctly, failure to do so could result in personal injury or equipment damage.

If you should find that you require information not covered in this manual, contact your local MORRIS Dealer. The Dealer will be glad to answer any questions that may arise regarding the operation of your MORRIS 9 Series Air Cart.

MORRIS Dealers are kept informed on the best methods of servicing and are equipped to provide prompt efficient service if needed.

Occasionally, your 9 Series Air Cart may require replacement parts. Your Dealer will be able to supply you with the necessary replacement parts required. If the Dealer does not have the necessary part, the MORRIS Factory will supply the Dealer with it promptly.

Your MORRIS 9 Series Air Cart is designed to give satisfaction even under difficult conditions. A small amount of time and effort spent in protecting it against rust, wear and replacing worn parts will increase the life and trade-in value.



Keep this book handy for ready reference at all times. It is the policy of Morris Equipment Ltd. to improve its products whenever it is possible to do so. The Company reserves the right to make changes or add improvements at any time without incurring any obligation to make such changes on machines sold previously.

Introduction - Continued

The MORRIS 9 Series Air Cart represents the latest in Air Cart design technology. Each cart incorporates a four wheel, wide-stance high clearance frame. The high clearance frame gives easy access to the metering wheels and the easiest cleanout in the industry. The tank lids are easily accessed by the convenient stairs and tank walkway.

Each tank has its own metering system and metering drive. Included with the unit is a sample collector box that an operator can use to confirm seeding rates.

The metering system incorporates spiral fluted wheels. The size of the metering wheel is matched to the number of outlets on the flat fan divider giving the best in accuracy. The spiral fluted metering wheels combined with the multi-range transmission allows a full range of products such as canola and peas to be seeded without having to change the metering wheels.

The VRT system enables the operator the ability to increase or decrease application rates from the tractor seat by pressing a button. Application rates can be changed on the go in pre-set increments from the operator set application rate. This gives the producer the ability to match application rates to varying soil requirements. With the addition of GPS prescription maps and Auto-Steer can be incorporated.



X30 Monitor - Shown

Standard Features

Hydraulic Auger

The hydraulic auger is designed to make loading and unloading product from the Air Cart tank very simple and easy. Shown here with optional extended hopper.



Introduction

Standard Features - Continued

Full Bin Indicator

The Morris 9 Series Air Cart can be equipped with an optional full bin indicator to alert when bins are full during loading.



Fill Indicator - Optional

Options

Hydraulic Conveyor

The 16" wide conveyor is designed to make loading and unloading product from the Air Cart tank very simple and easy.



Digi-Star Weigh Scale

The Morris 9 Series Air Cart can be equipped with an optional Digi-Star Weigh Scale to track product usage.



Digi-Star Weigh Scale

Options - Continued

Dual Fan

The dual fan system allows for higher application rates on larger five frame seed units.



Introduction

Notes

Section 5: Operation

Section Contents

Application	5-4
Tractor.....	5-4
Monitor Installation	5-5
Monitor Harness.....	5-6
Hitching to Tractor (Seeding Tool or Tow Between Cart)	5-7
Tractor Drawbar Requirements	5-7
9365 and 9450 - Tow Between.....	5-8
9445, 9550 and 9650 - Tow Between.....	5-9
9555, 9680 and 9800 - Tow Between.....	5-9
Hitching to Seeding Tool (Tow Between Cart)	5-10
Hitching Front Castor (Tow Behind Cart).....	5-10
Hitching to Seeding Tool (Tow Behind Cart)	5-11
Hydraulic Connections	5-13
Unhitching from Seeding Tool (Tow Between Cart)	5-14
Unhitching from Tractor (Seeding Tool or Tow Between Cart)	5-14
9365 and 9450 - Tow Between.....	5-14
9445, 9550 and 9650 - Tow Between.....	5-15
9555, 9680 and 9800 - Tow Between.....	5-15
Unhitching from Seeding Tool (Tow Behind Cart).....	5-16
Quad Steer Operation	5-17
Brakes	5-18
In-Cab Brake Controller	5-18
Operation	5-19
Installation.....	5-20
Transport	5-22
Speed.....	5-22
Lights	5-22
Tow Hitch (Tow Behind Units)	5-22

Operation

Section Contents - Continued

Preparing VR System	5-23
Hydraulic Motor Solenoid	5-23
Verify VR Hydraulic Assembly	5-23
Hydraulic Diagram	5-24
Metering System	5-25
Secondary Hose Installation	5-26
Seed Plate Setting	5-27
Seed Plate Adjustment	5-28
Bin Level Adjustment	5-29
Full Bin Indicator	5-29
Digi-Star Weigh Scale	5-30
Hydraulic Assist Conveyor/Auger	5-31
Remote Controller Operation	5-31
Auger	5-32
Manual Arms	5-32
Hydraulic Assisted Arms	5-33
Extension Hopper	5-34
Conveyor	5-35
Hydraulic Assisted Arms	5-35
Conveyor Storage Position	5-36
Conveyor Belt Speed	5-36
Operation	5-37
Startup and Break-In	5-37
Conveyor Adjustments and Maintenance	5-38
Cleaning/Inspecting the Conveyor - 8 hours or Daily	5-39
Conveyor Belt/Tail End Care	5-39
Semi Trailer Filling Positions	5-40
Semi Trailer Dump Positions	5-53
Filling Tank	5-57
Unloading Tanks	5-61
Rate Calibration	5-63
Metering Rate Adjustment	5-66
Seeding Fine Seeds (Canola, Mustard, etc.)	5-66
Applying Inoculant	5-66
Hydraulic Fan Drive	5-67
Fan Speed Recommendations	5-68
Plenum Settings	5-71
Double Shoot Settings	5-72
Collector Valve Settings	5-72
Flapper Valve Run Test	5-72
Operating Guidelines	5-73
Check Tire Pressures	5-73
Level Seeding Tool	5-73
Worn Seeding Tool Parts	5-73
Packing	5-73
Turning	5-74
Seed Rate Settings	5-74
Fertilizer Application	5-74
Fan Setting	5-74
Product Application	5-74
Adjustments and Operational Checks	5-75
Checking Seed Flow	5-75

Section Contents - Continued

Moisture Alert.....	5-75
Air Leaks	5-75
Tank Low in Product.....	5-75
Monitor	5-76
General Field Operation	5-76

Operation

CAUTION



BE ALERT

SAFETY FIRST

REFER TO SECTION 1 AND REVIEW ALL
SAFETY RECOMMENDATIONS.

Application

The Morris 9 Series Air Cart applies a wide range of seed and granular fertilizer products. It has the capacity to single shoot and double shoot. See “Double” for more details.

Tractor

Tires

- Proper ballast and tire pressure are required when pulling heavy implements.
- Consult your tractor operator’s manual and follow all recommended procedures.

Hydraulics

- Wipe all hydraulic fittings and couplers with a clean cloth to avoid contaminating the system.
- Check that hydraulic reservoir is filled to the proper level.

Drawbar

- Centre and pin in a fixed position for easier hitching and greater stability.



Warning

Do not permit smoking, sparks or an open flame where combustible fuels are being used. Keep the work area well ventilated.



Warning

Do not search for high pressure hydraulic leaks without hand and face protection. A tiny, almost invisible leak can penetrate skin, that requires immediate medical attention.

Monitor Installation

X35 Monitor

1. Install **1019154-01** Power/Comms Harness on tractor. Plug directly into the Tractor's power bar with AGA5246 Power Cable. If Tractor does not have power bar and requires direct connection to battery use optional 1006970-01 Power Cable.

Important: Battery leads from the Harness must be connected directly to the battery.

Do not connect directly to starter switch.

2. Mount X35 monitor in tractor cab in an easily visible position.
3. Connect **1019154-01** Power/Comms Harness to X35.
4. Refer to Monitor manuals for more details:
 - For X30 monitor manual N55777 and X30 ICT manual N55799.
 - For X35 monitor manual N65100 and X35 ICT manual N65101.

Get the most current version of the Monitor manuals at:
<http://www.morris-industries.com/service/product-downloads/>

Important

Some tractors have a 24 volt starting system. Neither the monitor nor the VRT control will operate if they are connected to a 24 volt system. If in doubt, always connect to one battery only.



X35 Monitor - Shown

Important

Ensure harness extensions, when routed over the seeding tool and air cart, are clear of moving parts and protruding objects that may cut wires.



1019154-01 POWER / COMMS HARNESS

Operation

Monitor Installation - Continued

Monitor Harness

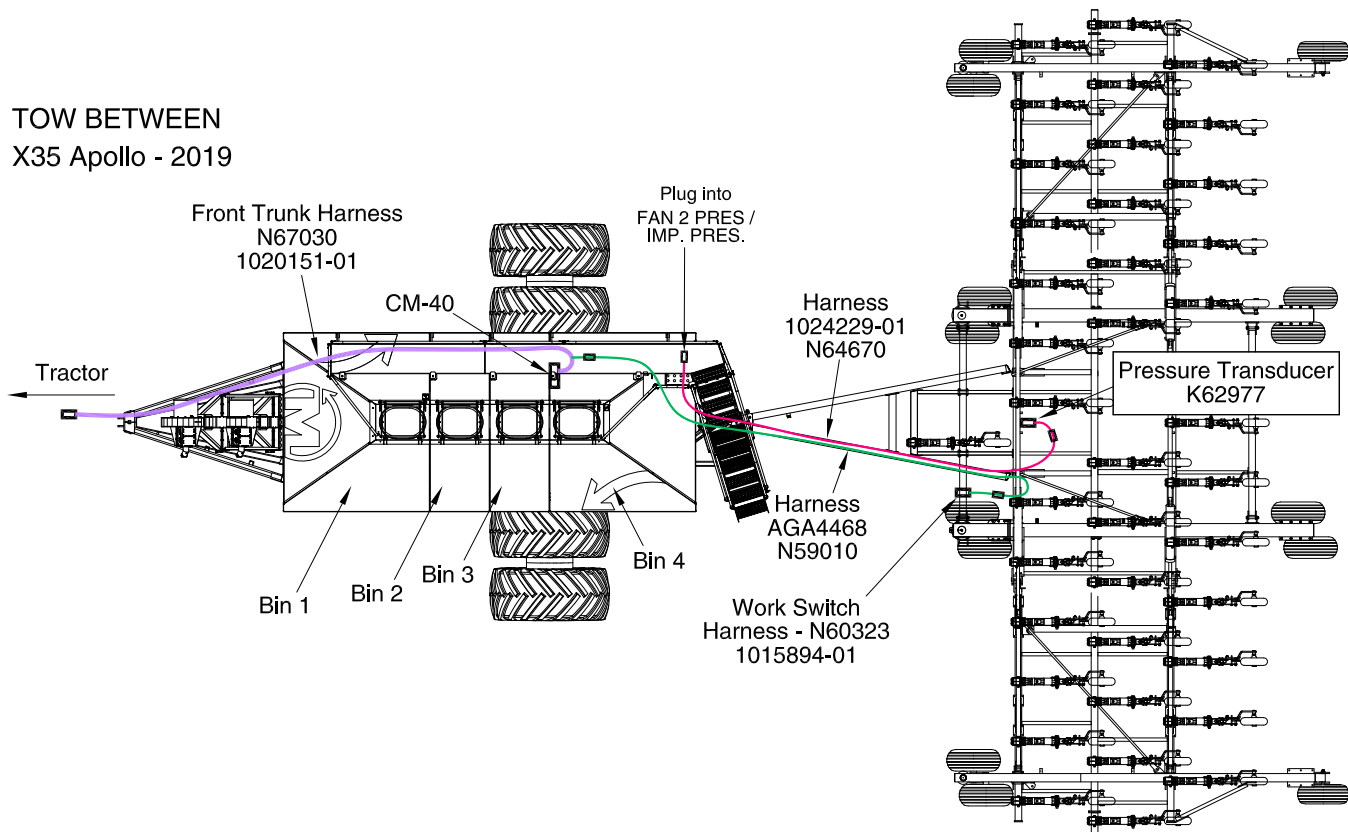
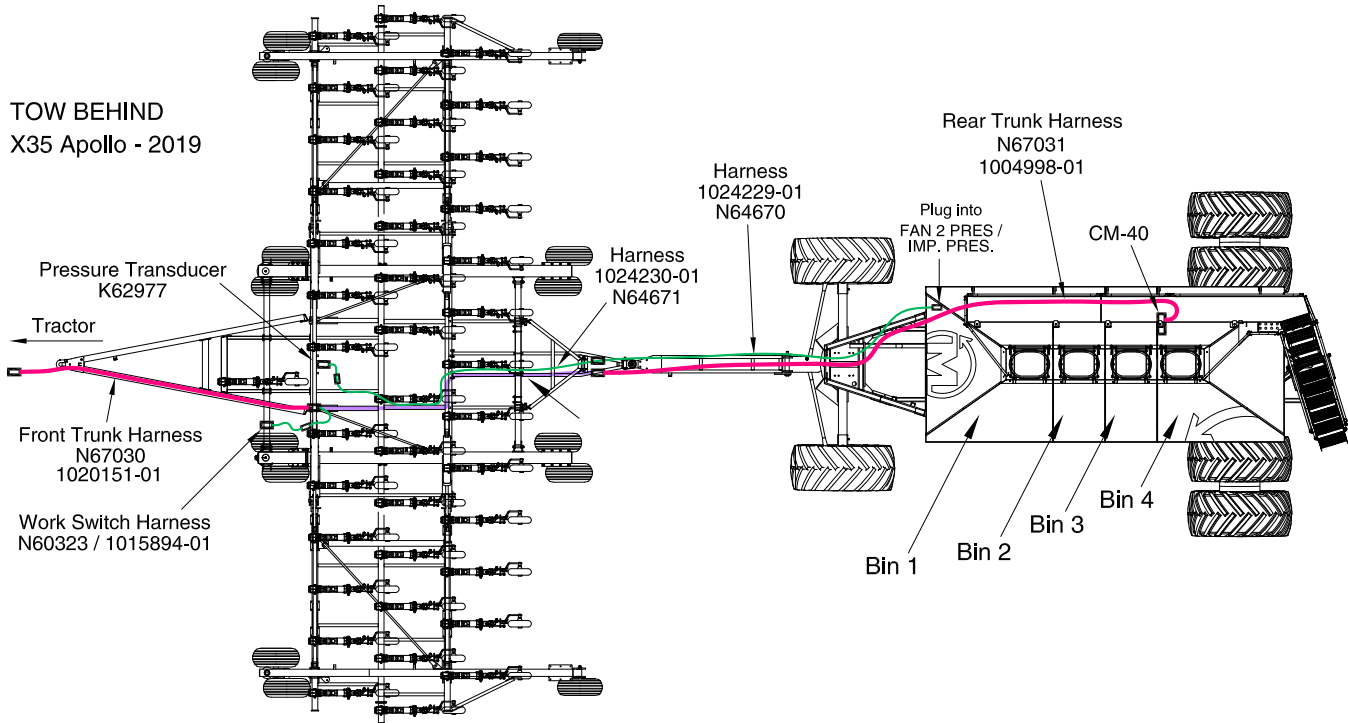

Caution

A safety chain will help control towed machines should it accidentally separate from the drawbar while transporting. A runaway machine could cause severe injury or death. Use a safety chain with a strength rating equal to or greater than the gross weight of the towed machines.

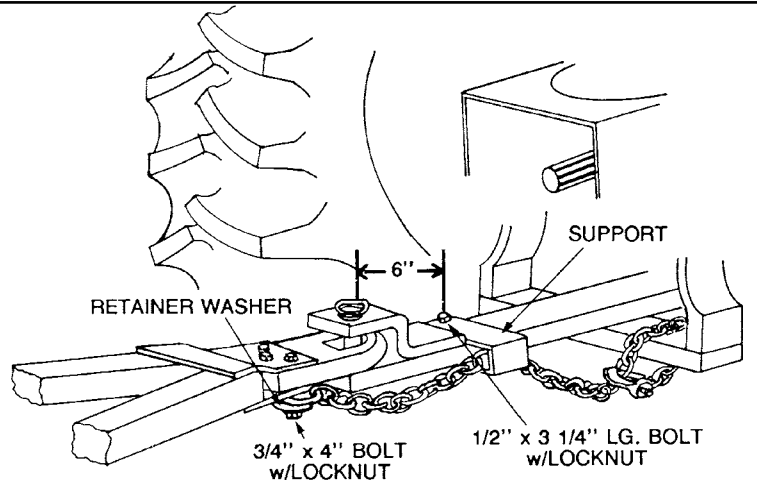

Attach safety chain to the tractor drawbar support or other specified anchor location with the appropriate parts.

Hitching to Tractor (Seeding Tool or Tow Between Cart)

Tractor Drawbar Requirements

Tractor drawbar vertical load requirements for loaded Tow Between Air Carts are as follows:

9365.....	8,500 lbs (3,864 kg) minimum
9450.....	11,000 lbs (5,000 kg) minimum
9445, 9550 & 9650 ...	8,900 lbs (4,050 kg) minimum
9555, 9680 & 9800 ...	12,000 lbs (5,443 kg) minimum



Operation

Hitching to Tractor (Tow Between Cart) - Continued

9365 and 9450 - Tow Between

- Ensure swinging drawbar is locked in the centre position.
- Ensure hitch pin is in good condition.
- Level clevis with tractor drawbar using hitch jack.
- Back tractor into position and attach hitch clevis to drawbar, using an adequate hitch pin.
- Lock hitch pin in place with a hairpin or other proper locking device.
- After tractor to implement connection is made, relieve pressure off the hitch jack.
- Place hitch jack in raised position.
- Route Safety Chain through chain support and drawbar support.
- Lock safety hook onto chain.

Note: Provide only enough slack in chain to permit turning.

- Ensure hydraulic hose quick couplers are dirt free.
- Inspect all fittings and hoses for leaks and kinks. Repair as necessary
- Connect the hydraulic hoses to the tractor quick couplers.



Caution

Dirt in the hydraulic system could damage O-rings, causing leakage, pressure loss and total system failure.

Note: Stairway down indicator will flash when stairs are in lowered position.



Important

Raise Stairs before moving Cart.
Stair damage will occur in lowered position.



Hitching to Tractor (Tow Between Cart) - Continued

9445, 9550 and 9650 - Tow Between

9555, 9680 and 9800 - Tow Between

(Optional for 9365 and 9450)

- Ensure swinging drawbar is locked in the centre position.
- Ensure hitch pin is in good condition.
- Back tractor into position with drawbar a couple of feet in front of cart hitch clevis.
- Ensure hydraulic hose quick couplers are dirt free.
- Inspect all fittings and hoses for leaks and kinks. Repair as necessary
- Connect the hydraulic hoses to the tractor quick couplers.
- Unlock hydraulic hitch jack line lock valve.
- Operate tractor hydraulics to extend hydraulic hitch jack.
- Disengage hydraulic hitch jack lock.
- Operate tractor hydraulics to level clevis with tractor drawbar using hydraulic hitch jack.
- Back tractor into position and attach hitch clevis to drawbar, using an adequate hitch pin.
- Lock hitch pin in place with a hairpin or other proper locking device.
- After tractor to cart connection is made, raise hydraulic hitch jack fully.
- Lock hydraulic hitch jack line lock valve.
- Route Safety Chain through chain support and drawbar support.
- Lock safety hook onto chain.

Note: Provide only enough slack in chain to permit turning.



Caution

Dirt in the hydraulic system could damage O-rings, causing leakage, pressure loss and total system failure.

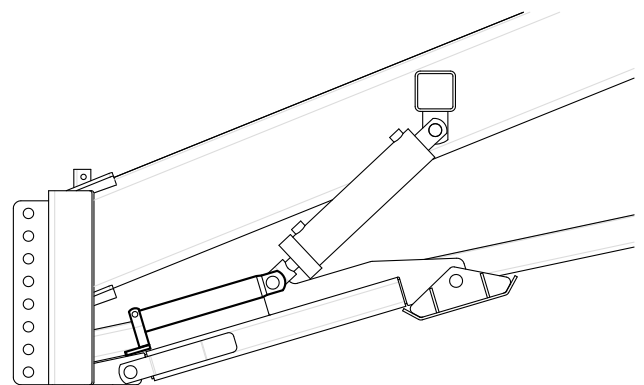
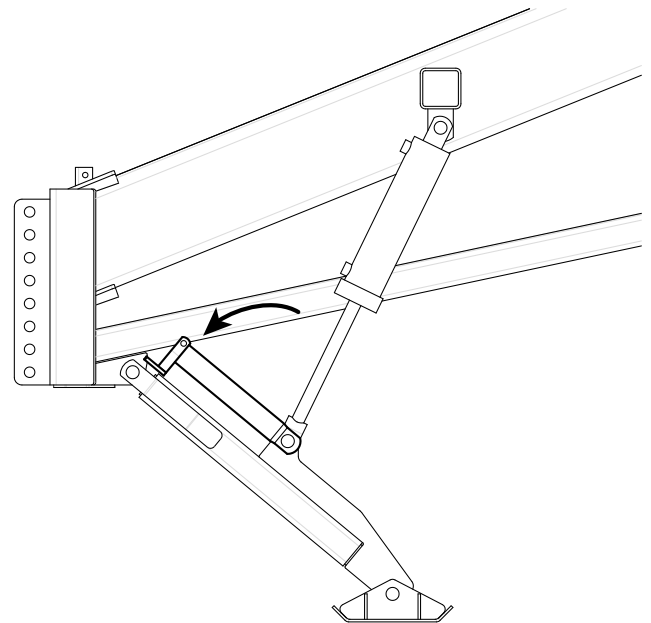

Operation

Hitching to Seeding Tool (Tow Between Cart)

- Connect air cart to tractor.
- Back air cart into position, aligning seeding tool hitch with air cart.
- Attach hitch to air cart with 1 1/2" x 6 1/2" pin and retain with a 1/4" hair pin.
- Attach safety chain to air cart.

Note: Provide only enough slack in chain to permit turning.

- Connect hydraulic hose quick couplers.
- Connect the primary hose couplers.
- Loop retaining chain around the primary hoses with the secondary hose over the bottom half of the chain.

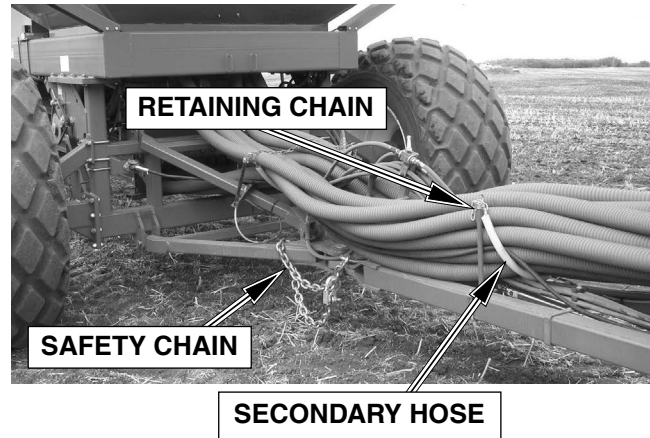

Hitching Front Castor (Tow Behind Cart)

- Assemble hitch components to the front castor axle as shown in the accompanying diagram. Item (7) is 1 1/2" x 5 1/8" lg pin. Item (8) is 1 1/2" x 6 7/16" lg pin and Item (9) is 1 1/2" x 8 3/8" lg pin.

Note: Pin item (9) holding item (4) cannot be installed or removed with the wheel assembly mounted.

- Assemble safety chain to item (1) using 1" Unitorque nut and 1 1/16" ID flatwasher.

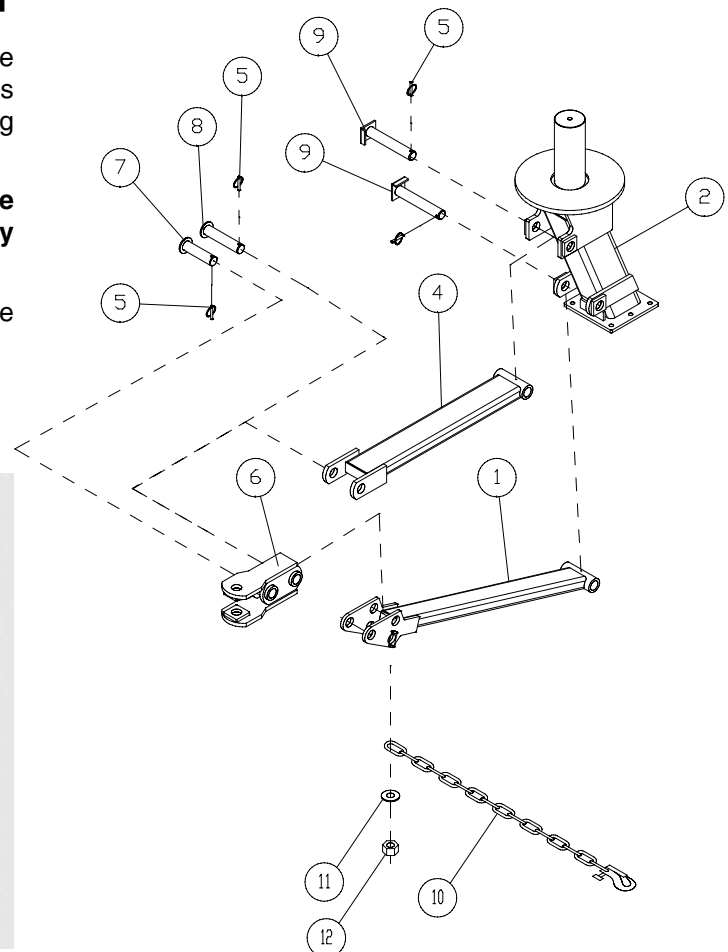
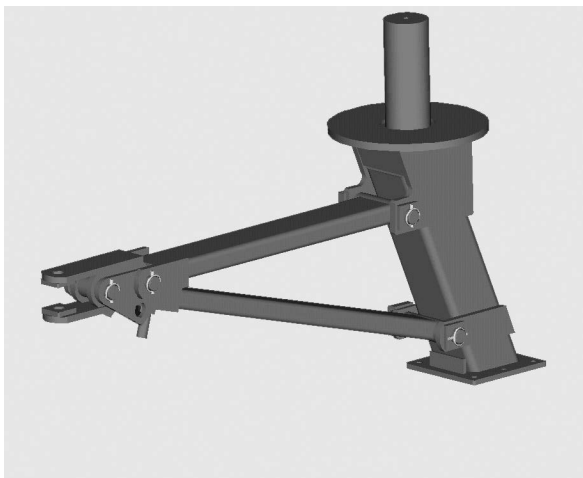

Hitching to Seeding Tool (Tow Behind Cart)

- Connect seeding tool to tractor.
- Attach hitch to air cart with 1 1/4" x 5" pin.
- Back seeding tool into position with air cart.
- Extend the telescopic hitch arms and connect the air cart to seeding tool using 1 1/8" x 3 11/16" pins.
- Block the tires of the air cart and insert the 1" x 5 13/32" pins into their bushings.
- Slowly back seeding tool toward air cart until the telescopic arms are fully retracted and the pins drop through the hitch tube locking the hitch poles.
- Retain the pins with click pins.
- Attach safety chain to air cart.

Note: Provide only enough slack in chain to permit turning.

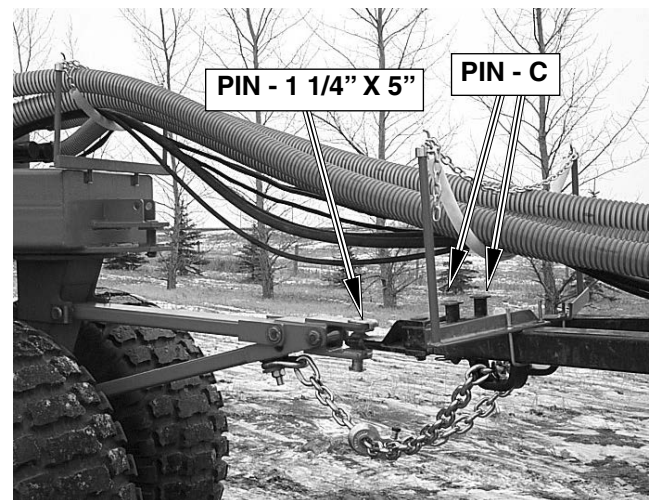
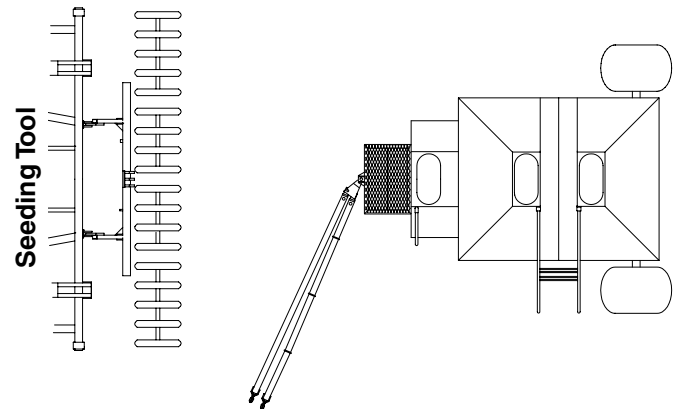

PIN SIZE	
A	1 1/8" x 3 11/16"
B	1 1/2" x 5 5/8"
C	1" x 5 13/32"
D	1" x 3 3/4"

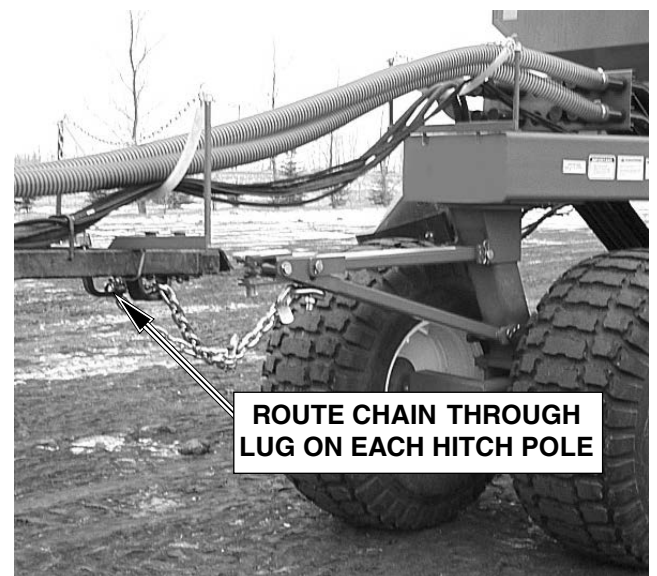
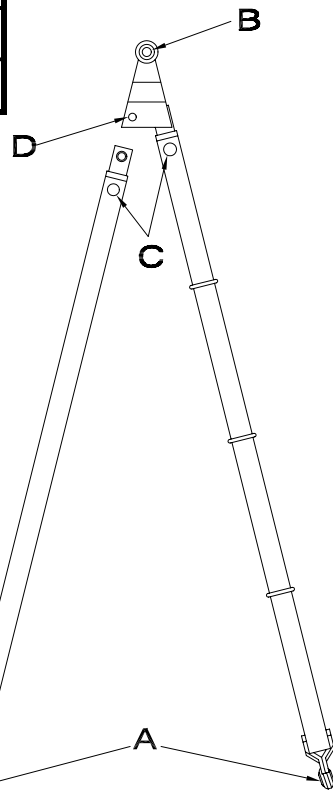

Operation

Hitching to Seeding Tool (Tow Behind Cart) - Continued

- Route monitor wires and hydraulic lines through rear retaining chain with the secondary hose over the bottom half of the chain.
- Route monitor wires through the loops on the left hand hitch pole.
- Route the hydraulic lines (if any) through the loops on the left hand hitch pole.
- Connect the primary hose couplers.
- Loop retaining chain around the primary hoses with the secondary hose over the bottom half of the chain.
- Connect the monitor quick connectors at both the tractor/seeding tool and the seeding tool/air cart connections.

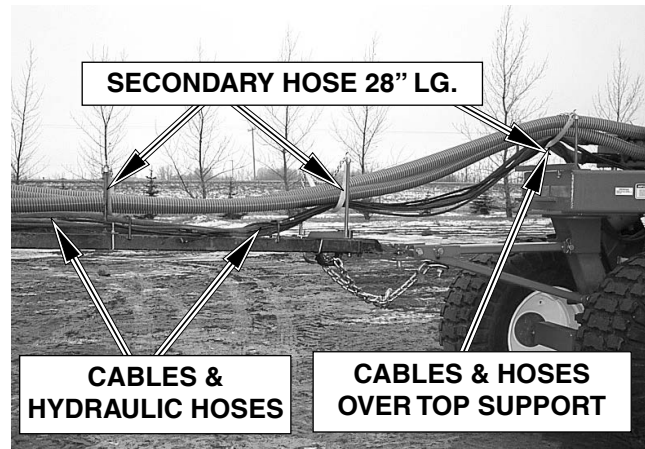

Hoses with correct amount of sag

Important

Extreme care is required when backing up unit.

Hitch damage will occur if castor jackknifes.

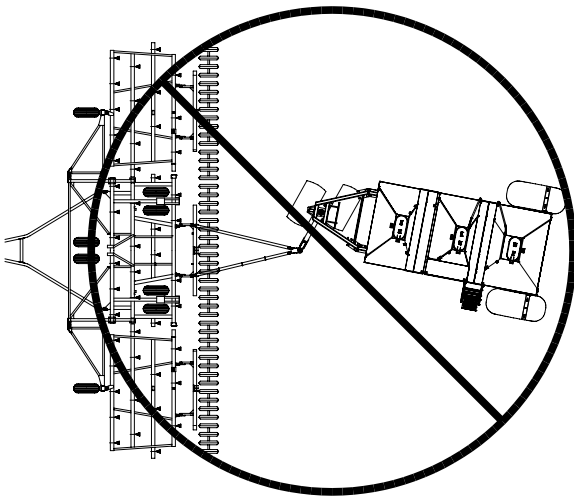

Primary Hose Coupler - Tow Between Shown

Important

Raise Stairs before moving Cart.

Stair damage will occur in lowered position.



Hitching to Seeding Tool (Tow Behind Cart) - Continued

Hydraulic Connections

- Connect the monitor quick connectors at both the tractor/seeding tool and the seeding tool/air cart connections.
- **Hydraulic fan drive**, connect the fan hydraulic quick couplers at both the tractor/seeding tool and the seeding tool/air cart connections. Ensure couplers are clean and dirt free.

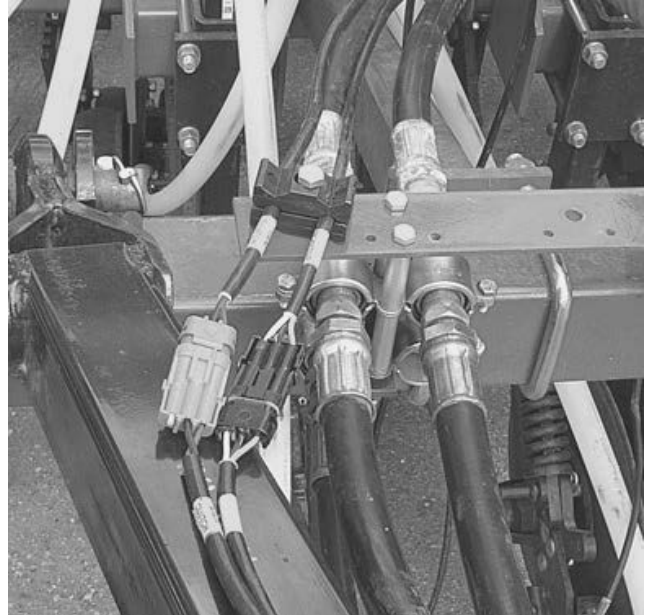

Seeding Tool Coupling

CAUTION

Hydraulic oil under pressure can penetrate the skin causing serious injury. Avoid personal injury by relieving all pressure, before disconnecting hydraulic hoses.

Note: The case drain 3/8" diameter hose must be run directly into the hydraulic tank otherwise damage will occur to the seal in the motor. If the hose is run through the filler cap then ensure the cap is *VENTED*. A quick coupler can still be used between the tractor and the seeding tool.

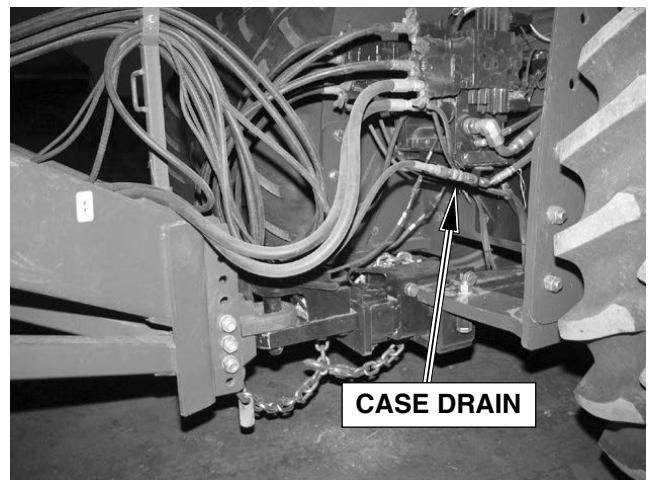

Hydraulic Coupling on Tractor

Operation

Unhitching from Seeding Tool (Tow Between Cart)

- Lower hitch jack taking the weight off the seeding tool hitch poles.
- Relieve pressure in the hydraulic hoses by positioning tractor hydraulic lever in “float” position or turn tractor engine off and cycle lever back and forth several times.
- Disconnect the primary hose couplers.
- Disconnect the hydraulic hoses.
- Remove the hitch pin.
- Slowly move air cart away from seeding tool.

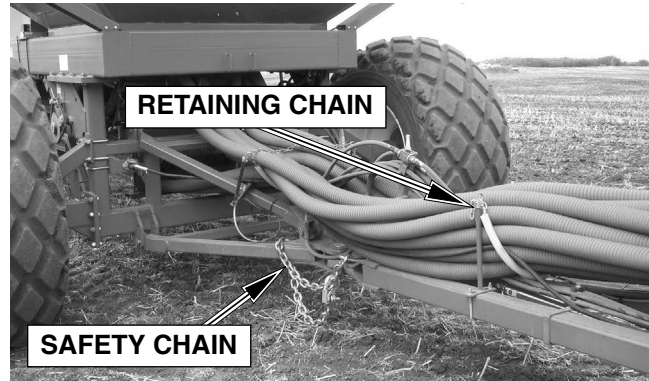

Unhitching from Tractor (Seeding Tool or Tow Between Cart)

9365 and 9450 - Tow Between

- Pin hitch jack in working position.
- Lower hitch jack taking the weight off the air cart clevis.

Note: For added safety it is recommended to unload any material that may be in the tanks.

- Ensure all transport locks are properly secured. Refer to seeding tool manual for more details.
- Relieve pressure in the hydraulic hoses by positioning tractor hydraulic lever in “float” position or turn tractor engine off and cycle lever back and forth several times.
- Disconnect the hydraulic hoses.
- Disconnect the clutch and monitor cables.
- Remove the safety chain.
- Remove the drawbar pin.
- Slowly move tractor away from seeding tool or tow between cart.



Tow Between Cart

Unhitching from Tractor (Seeding Tool or Tow Between Cart) - Continued

9445, 9550 and 9650 - Tow Between

9555, 9680 and 9800 - Tow Between

(Optional for 9365 and 9450)

- Unlock hydraulic hitch jack line lock valve.
- Operate tractor hydraulics to lower hydraulic hitch jack taking the weight off the air cart clevis.

Note: For added safety it is recommended to unload any material that may be in the tanks.

- Disconnect the clutch and monitor cables.
- Remove the safety chain and drawbar pin.
- Slowly move tractor one foot (30 cm) away from cart.
- Operate tractor hydraulics raising cart hitch to fully extend hydraulic hitch jack.
- Engage hydraulic hitch jack lock.
- Ensure all transport locks are properly secured. Refer to seeding tool manual for more details.
- Relieve pressure in the hydraulic hoses by positioning tractor hydraulic lever in “float” position or turn tractor engine off and cycle lever back and forth several times.
- Lock hydraulic hitch jack line lock valve.
- Disconnect the hydraulic hoses.
- Slowly move tractor away from seeding tool or tow between cart.

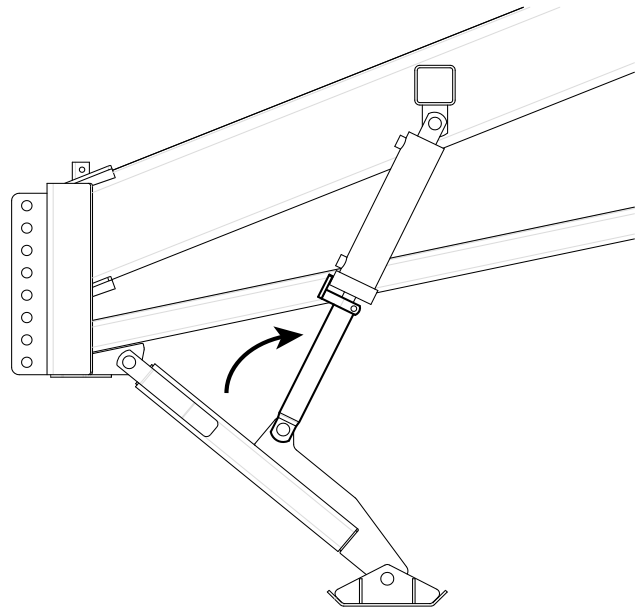

Operation

Unhitching from Seeding Tool (Tow Behind Cart)

- Lower hitch stands, if so equipped, taking the weight off the hitch poles.
- Relieve pressure in the hydraulic hoses by positioning tractor hydraulic lever in “float” position or turn tractor engine off and cycle lever back and forth several times.
- Disconnect the primary hose couplers.
- Disconnect the hydraulic hoses.
- Disconnect the clutch and monitor cables.
- Remove the hitch pins.
- Move hitch poles to the side of air cart, if not equipped with hitch stands.
- Slowly move seeding tool away from air cart.

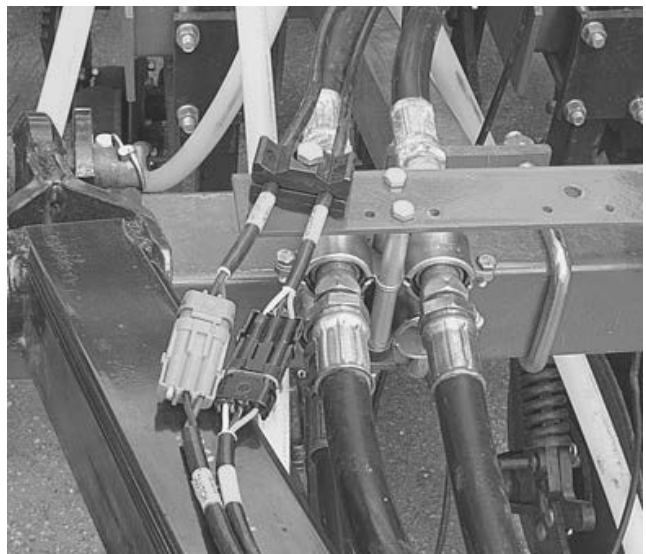
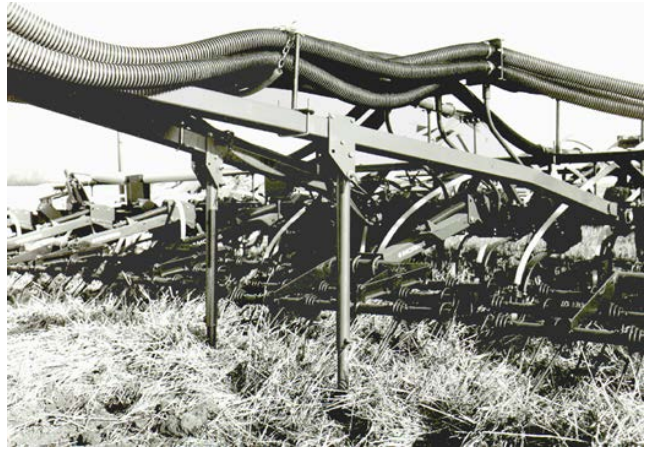

Seeding Tool Coupling

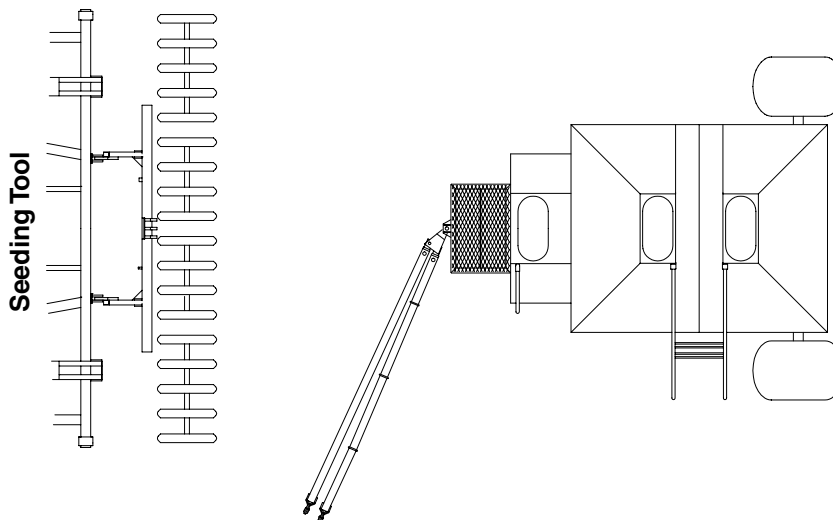

Quad Steer Operation

- Ensure safety chains are used at hitch pole connection to seeding tool.
- Retorque axle pivot bolts after first 2 hours and periodically afterwards. See “Quad Steer” in Maintenance Section for details.
- Retorque wheel nuts to 400 lb-ft after first fifteen minutes of operation and every fifteen minutes for the next 2 hours. Check periodically afterwards.
- Avoid sharp turns which cause the steering to reach its limits and drag the front tires of the cart.
- Do not tow any implements behind cart.
- Do not tow cart in excess of 20 mph.
- Do not transport fully loaded cart on roadways.
- Use manufacturer’s rims and tires only.



Important

Extreme care is required when backing up unit.

Hitch damage will occur if axle jackknives.



Operation

Brakes

Morris is using Titan's BrakeRite II brake actuation system located on back of frame near rear tires. The Titan BrakeRite II is an electric over Hydraulic brake system. The BrakeRite system is actuated when the brake pedal of the tractor is depressed. The Air Cart brakes can also be applied independently by applying the manual over-ride on the In-Cab Brake Controller.

In-Cab Brake Controller

The In-Cab Brake Control is equipped with a gain control to adjust the braking of the Cart to match operating conditions. The Controller is also equipped with a manual override button to apply the brakes on the Air Cart without applying the brakes on the tractor.

Toggle Switch Functions

- Switch Up (Towards the Operator) brake signal in is turned OFF (RED light flashes). Towing brake signal is used elsewhere. Control will operate in the manual mode only (PUSH button).
- Switch Down (Away from Operator) control responds normally to external brake signal.

Turn Power ON

GREEN LED is ON, indicates control is powered up.

RED LED Light Bar turns on for 3/5 seconds and displays last gain setting. Also, power out to brakes is on for this period.

Set Gain

Press the + symbol to increase braking if inadequate Cart braking is being experienced.

Press the - symbol to decrease braking if excessive Cart braking is being experienced.

Note: These Buttons must be pressed repeatedly to change setting. Holding the buttons pressed only moves 1 step. Gain settings can be changed only when there is no external brake signal present.

Manual Operation

Press "PUSH" button with variable force to apply brakes manually. This button is pressure sensitive.

Higher Pressure on button = Higher brake pressure

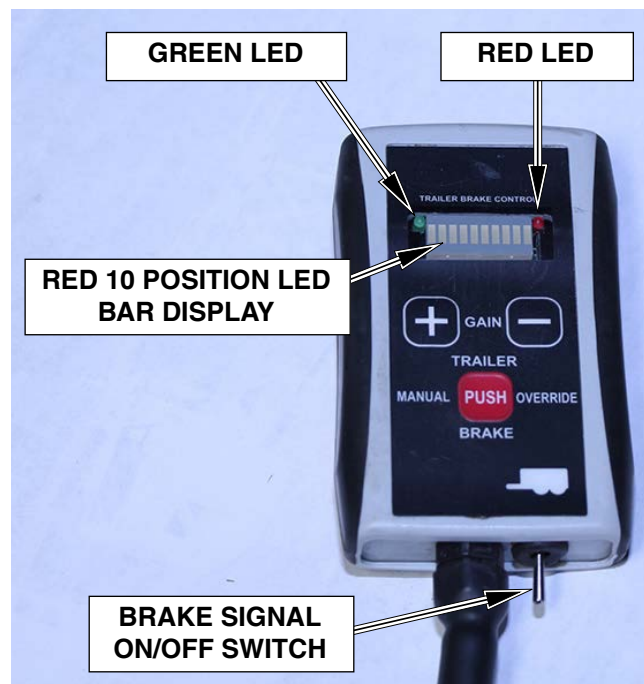

GREEN LED is ON when 12v power is in control.

RED LED flashes when brake switch is in the OFF position.

RED 10 positions LED Bar displays gain and level of braking.

Brakes - Continued

Operation

Before using the Air Cart always check:

1) Proper Brake Fluid Level:

Must be between 3/8 & 3/4 inch of filler opening.

2) Prior to Moving the Coupled Unit:

a. Verify the brake system is working properly.

To assure proper connections have been made, check In-Cab Controller green LED should light when switch is in ON position. Before moving the Cart depress the Tractor brake pedal, the BrakeRite unit should start (you can hear the unit running). Release the Tractor brake pedal and activate the BrakeRite unit by operating the “manual override” on the In-Cab Controller, again you will hear the unit turn on. With the manual override you are able to tell by the change in tone that the system is building pressure relative to the amount of “activation” initiated on the override switch. **Do Not attempt to move the unit until the brake system performs in the tests described above.**

3) When Operating/Transporting the Air Cart:

- a. Do not rely on the Air Cart brakes for deceleration of the entire combined unit braking. The Air Cart Brakes are designed for braking of the Air Cart only and not the entire combined unit.
- b. Always operate the combined unit within the specified parameters outlined in the Tractor Owner Manuals and OBEY ALL LAWS.

PROPER ELECTRICAL WIRING is CRITICAL for the performance of any of these systems. Improper wiring can result in damage to the actuation system or system failure after initial use. A “pure ground” and direct power (+12 VDC) with fuse or circuit breaker (30 amp) are necessary to ensure good performance.

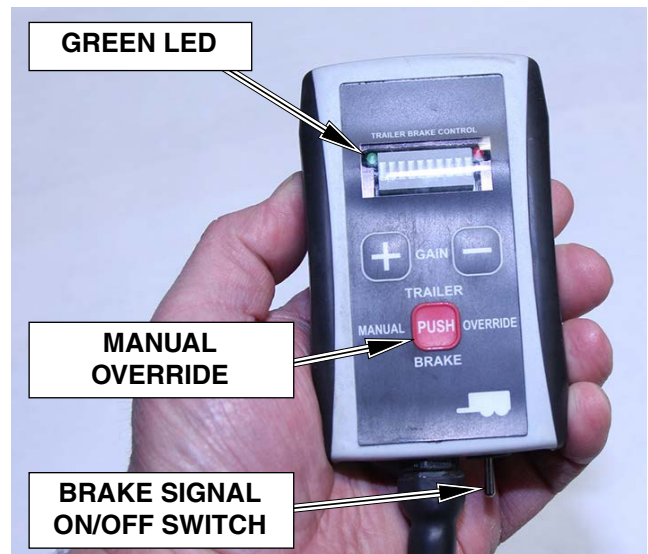

Important:

Use only DOT III brake fluid.

Maintain fluid level within 3/8 to 1/2 inch below the filler opening.

Use caution when removing the filler cap to prevent contaminants entering into the fluid reservoir.

Brakes - Continued

Installation - Continued

Item	Part No.	Description	Qty
1	D-4951	Nylon Tie Strap - 7 3/8 Lg.....	12
2	N16563	Slotted Screw - #8 x 1 1/4 Lg	4
3	N16564	Locknut - #8 Serrated.....	4
4	N34658	Aircart Lighting Harness.....	1
5	N53387	Brake Hose - 1/4 x 150 Lg.....	1
6	N53388	Brake Hose - 1/4 x 180 Lg.....	1
7	N53389	Brake Caliper	2
8	N53394	Control Module.....	1
9	N53396	BrakeRite SD II - Electric/Hydraulic Actuator.....	1
10	N53397	BrakeRite SD AG Controller	1
11	N53398	Brake Hose - 1/4 x 24	1
12	N53650	Wiring Harness - Cab Controller - 96 Lg Brake Lead	1
13	N53652	Brass Tee Fitting	1
14	N53653	Brass Brake Washer - 1/2 ID x 7/8 OD	2
15	N53654	Brass Adaptor - Brake Fitting.....	2
16	W-471	Bolt - 5/16 x 1 Lg.....	5
17	W-522	Lockwasher - 5/16.....	3
18	N53393	BrakeRite SD Breakaway switch	1
19	N53395	Brakerite SD Battery Cable - Optional battery hook up (Not Shown)	1
20	N53651	Wiring Harness - Brake Connector - 36 Lg Brake Lead	1
21	N55840	Plug - 5/16 MORB.....	2
22	N56076	Extension Harness - Cab Controller - 10 ft Lg.....	1
23	N53577	Battery - 250 CCA - Interstate #SP-30	1
24	N53571	Battery Cable -	1
25	N53569	Holder Plate - Battery	1
26	N53578	Bracket - Battery.....	2
27	N53579	Clamp Strap - Battery.....	1
28	N19723	U-Bolt- 3/8 Dia.x 4.063 x 6.938 UL	2
29	N15716	Seal Strip - 1/4 x 1/Foot	3 FT
30	D-5488	Washer - .344 x .688 x 16 Gauge	2
31	D-5579	Washer - .406 ID x 1 OD x 16 Gauge	4
32	D-5279	Locknut - 3/8 Serrated.....	8
33	C32925	Locknut - 5/16 Center.....	3
34	W-475	Bolt - 3/8 x 1 Lg.....	4
	N52683	Brake Hose Kit - (Contains Items 5, 6, 11, 13, 14 &15)	
	N53391	Brakerite SD Kit - (Contains Items 9 & 10)	

Operation

Transport

Observe all of the safety precautions under transport heading in Safety, Section 1.

- Refer to Specifications, Section 2, for weight, transport height, and width.
- Transport with tractor only!
- Use Tow Hitch when transporting without seeding tool (Tow Behind Units).
- Always connect safety chain provided to the towing vehicle and the hitch of the air cart.
- Do not transport with the fan running.
- Ensure all transport pins are secured.

Speed

- Always travel at a safe speed. Do Not Exceed 20 mph (32 kph) with an empty air cart.
- The combined weight of the implements being towed, including material in tank, **must not exceed 1.5 times** the weight of the towing tractor.
- Use additional caution when towing loads under adverse surface conditions, when turning, and on inclines.

Lights

- Ensure proper reflectors are in place, refer to Safety, Section 1.
- Be familiar with, and adhere to, local laws.

Tow Hitch (Tow Behind Units)

- Disconnect main hitch and remove the two pins connecting the hitch tube to the yard hitch tube.
- Attach hitch clevis to the yard hitch tube with two 1 1/2" x 5 1/8" and 1 1/2" x 6 7/16" pins.
- Retain the pins with klik-pins.
- Use tow hitch when towing without seeding tool.
- **Do not** use transport hitch with material in tank.

MORRIS EQUIPMENT LTD. WILL NOT BE RESPONSIBLE FOR ANY DAMAGES OR OPERATOR INJURY RESULTING FROM NON-USE OR IMPROPER USE OF TRANSPORT LOCKS.

Important

Raise Stairs before moving Cart.
Stair damage will occur in lowered position.

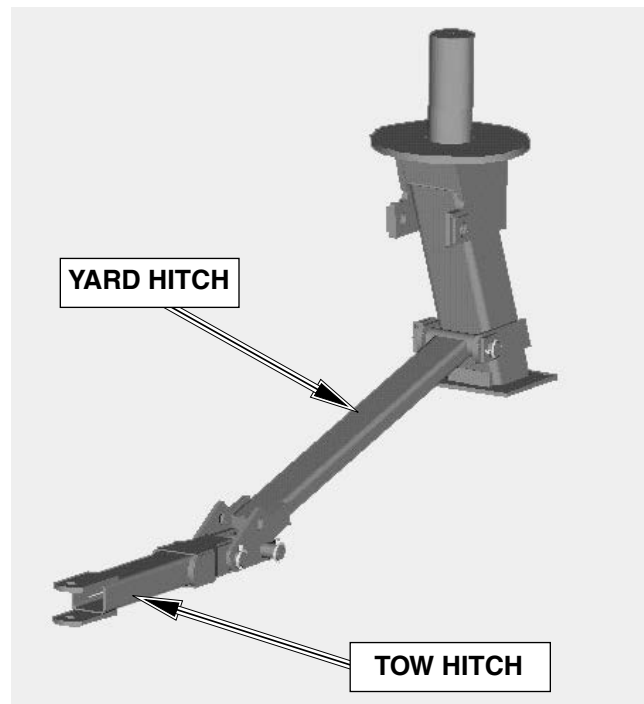

Tow Hitch

Preparing VR System

Hydraulic Motor Solenoid

The proportional valves are factory set with the valve adjusted all the way out. No further adjustment of the valve is required.

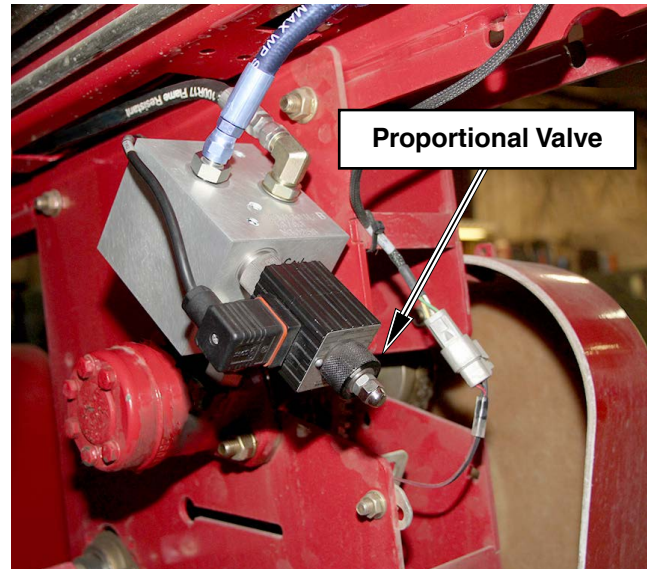

Verify VR Hydraulic Assembly

VR system should be run to confirm correct rotation of meter shafts.

The Rotation of the Meter Wheels should be the same as the forward travel of the Air Cart tires.

The diagram illustrates the correct rotation of the ICT meter body viewed from the right side of Cart.

Note: The pressure line from the tractor is the P1 port of the valve body.

The Hydraulic Diagrams on next page illustrates the correct hose orientations for the VR valve bodies.

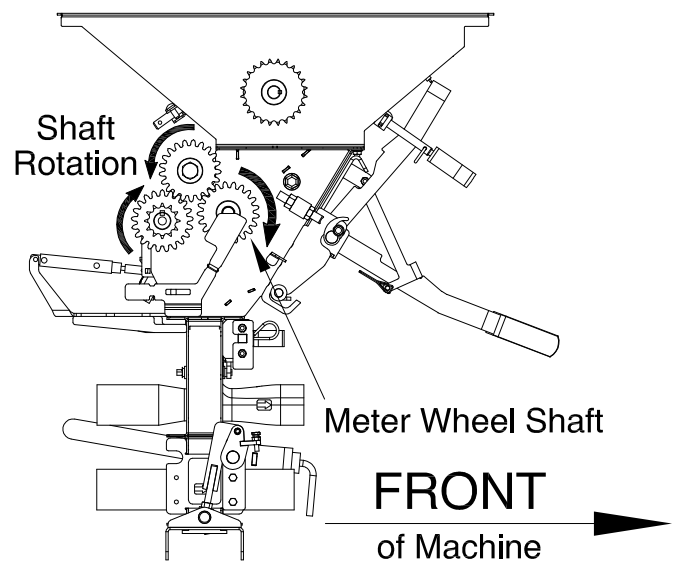

Operation

Preparing VRT - Continued

Hydraulic Diagram

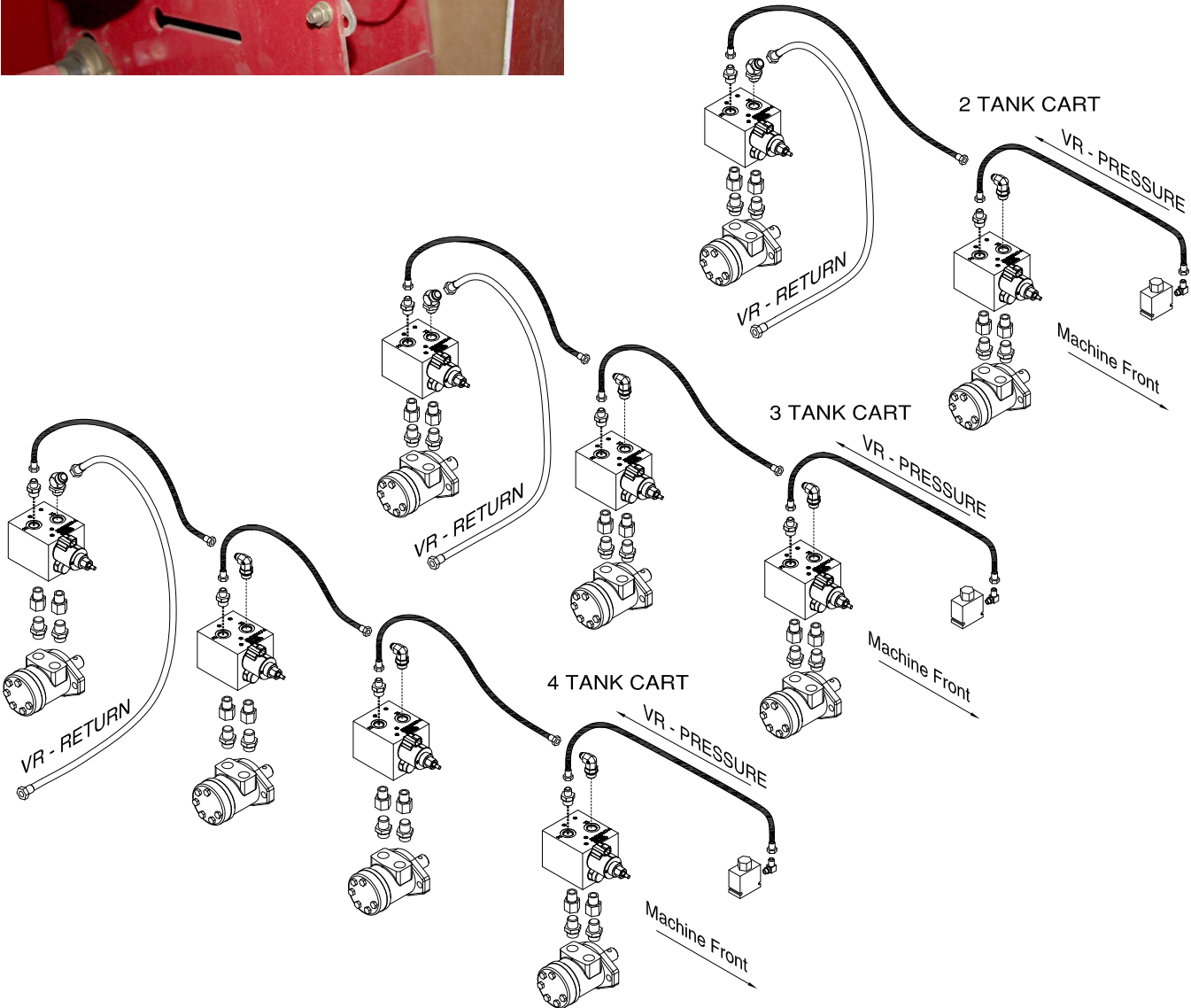
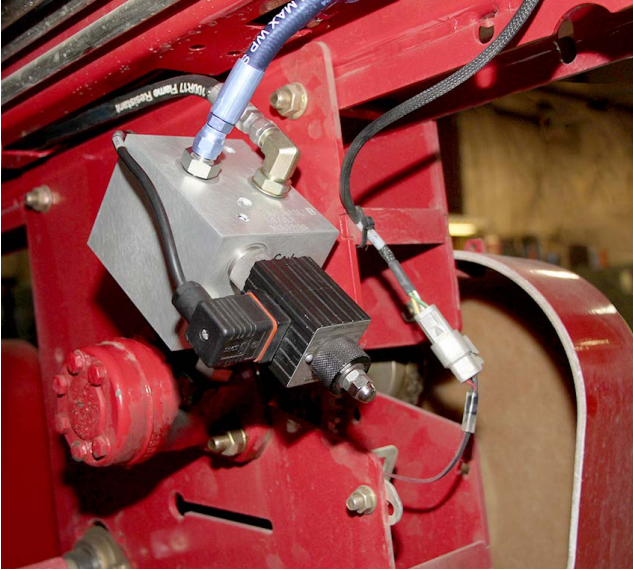

Metering System

The 9 Series Air Cart uses a combination of metering wheels and spacers shown below. The metering wheel is individually sized to correspond to the number of outlets at the connected secondary head and the spacers make up the space between the wheel and the body. Some openings may be blanked off depending on the number of secondary divider heads used on the seeding tool.

The 9 Series Air Cart can meter all types of seeds and fertilizers by simply installing the correct seed plate. See "Seed Plate Settings" for more details.

Different rates are easily obtained using the selection of quick change sprockets that attach to either of the two meter transmissions.

Note: Before putting product into the tanks check the following:

1. The correct Seed Plates are installed for the product being applied.
2. The clean-out doors are fully closed and sealed.
3. The plastic bag covering the fan is removed.

Important

Ensure distribution system is balanced. It is very important that head outlets only vary by one. (i.e. use only 7 and 8 together, 8 and 9 together, 9 and 10 together)

Note: The number of outlets on the divider head must match the metering wheel size.

10 Outlet Head

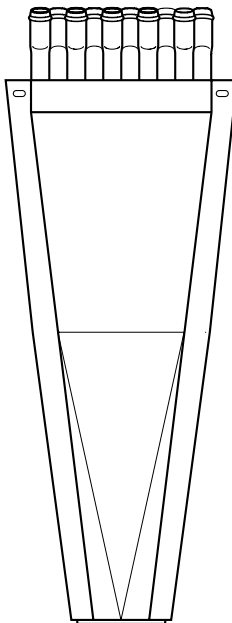

10 Outlet Metering Wheel with no spacer.

9 Outlet Head

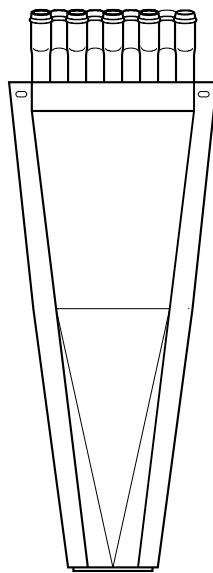

9 Outlet Metering Wheel with a single spacer.

8 Outlet Head

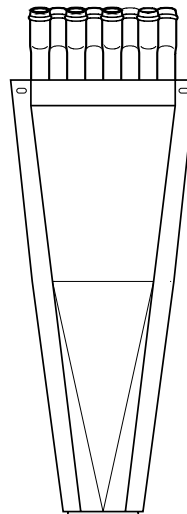

8 Outlet Metering Wheel with two single spacers.

7 Outlet Head

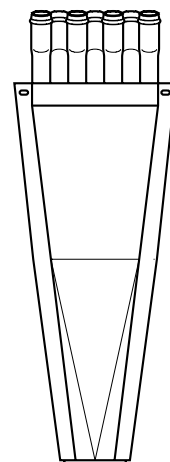

7 Outlet Metering Wheel with a single and one double spacer.

Operation

Metering System - Continued

Secondary Hose Installation

The lengths of the 15/16" (24 mm) diameter hoses are **very important**.

For accurate distribution the secondary hoses have to be arranged by length symmetrically around the centre line.

The **longest** hoses **have to be** in the **centre** of the divider head. These hoses would normally feed the openers furthest away from the head.

- Ensure that the secondary hoses 15/16" (24 mm) diameter do not run higher than 3" (76 mm) above the height of the flat fan divider head.
- Allow an extra 3" (76 mm) of hose before cutting secondary hose for fitting in the seed boot.
- Always ensure that the secondary hoses are sufficiently long to accommodate tripping of trips.
- **Avoid sharp bends** in any of the hoses.
- Check for pinch points and clearances when folding in and out of transport.

Important

Hot water is the only acceptable lubricant for the installation of the secondary hose.

The supplier advised MORRIS that WD-40 or any other lubricant (i.e. liquid detergent) will have a negative effect on the chemical stability of the hose, resulting in the degradation and failure of the hose due to Environmental Stress Cracking.

Important

Distribution uniformity will be adversely affected if hoses are incorrectly installed.

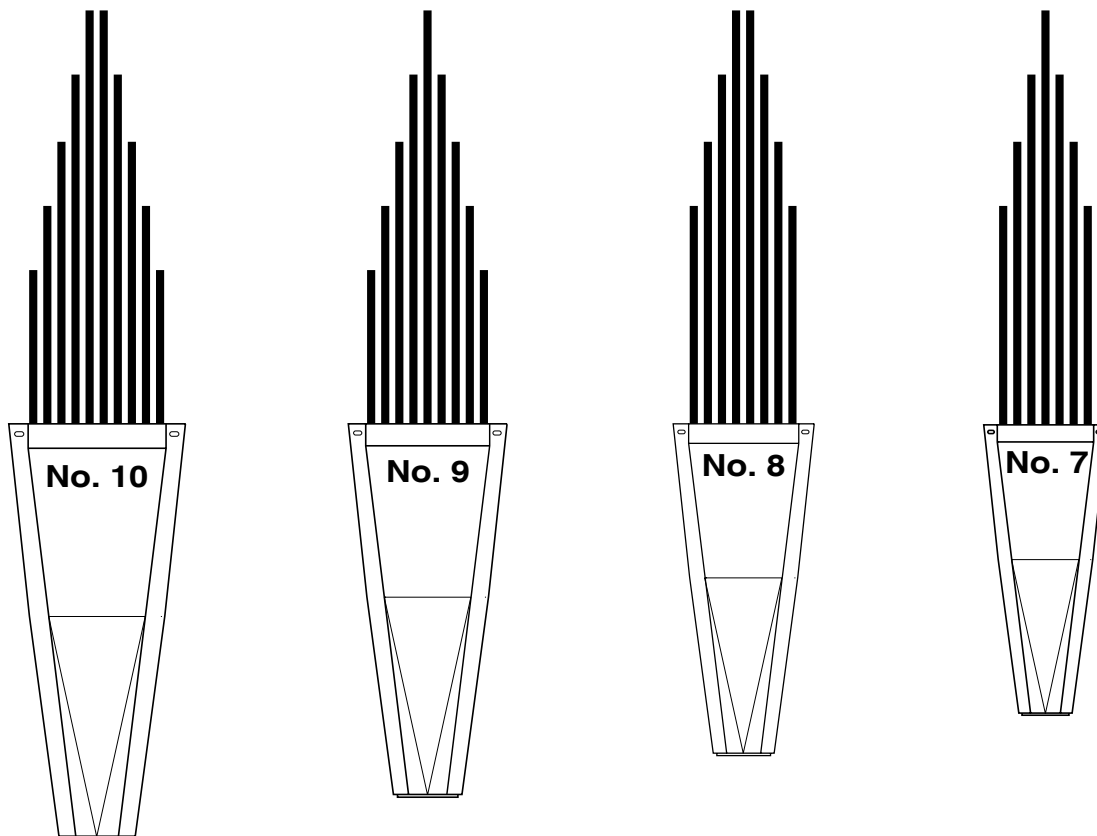

Metering System - Continued

Seed Plate Setting

Each meter wheel has an adjustable seed plate.

The seed plates are adjusted by a single lever adjustment on the metering body assembly.

Note: Seed Plate Chart is a suggested usage. Product variations could require a different seed plate to be used for proper metering.

i.e. Clean 11-51-0 Fertilizer may require a Medium seed plate setting to reduce product flow.

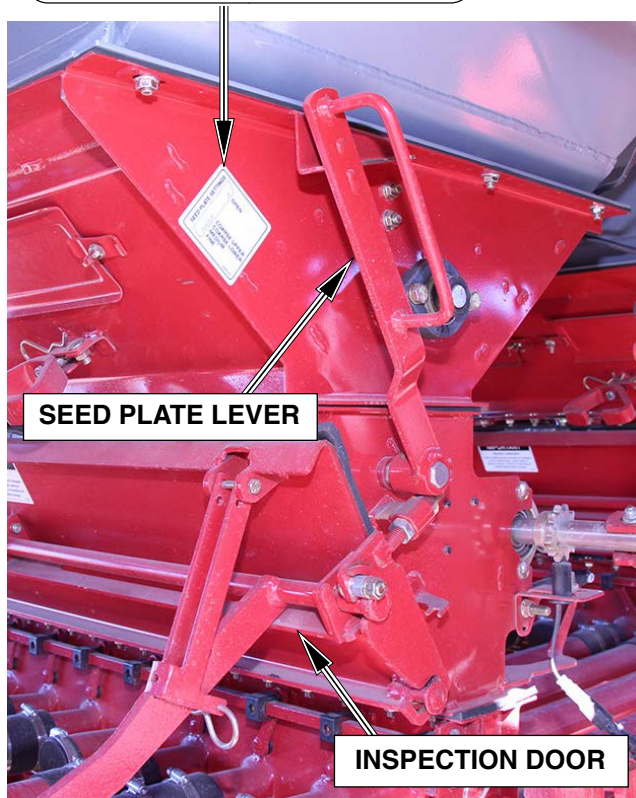
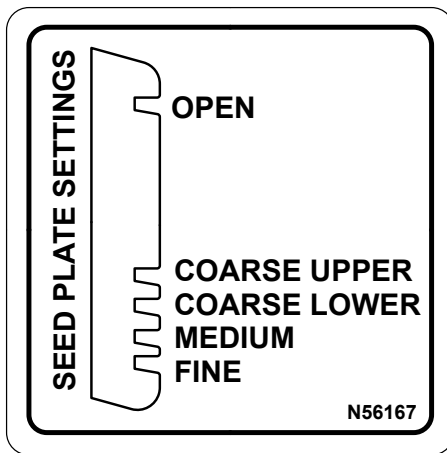

Important

Do not try and close the seed plates with the product in the metering body as damage can occur from the product being squeezed between the wheels and seed plates.

Seed Plate Usage

Product	Seed Plate
Canola Canary Seed Clover/Alfalfa Flax Mustard Nitragin Edge Fortress Rival	Fine
Barley Lentils Milo Oats Rice Wheat Safflower Nodulator Tag Team Fine Fertilizer (no Sulphur or Potash) 28-0-0 Fertilizer 46-0-0 Fertilizer 34-17-0 Fertilizer 20.5-0-0-24 Fertilizer	Medium
Beans Peas Soybeans Sunflowers 0-0-60 Fertilizer 0-45-0 Fertilizer 10-46-0-0 Fertilizer 11-51-0 Fertilizer Fertilizers containing Sulphur and/or Potash	Coarse

Operation

Metering System - Continued

Seed Plate Setting - Continued

- Ensure Tank Shut-Offs are closed if there is product in the tanks.

Note: Tank Shut-Offs are only for use when inspecting/servicing meter body with product in tank.

- Open inspection door and rotate seed plate fully open.
- Inspect Seed Plates and meter wheels to ensure they are free of debris.
- Set seed plate lever to appropriate notch per Seed Plate Usage chart.
- Close inspection door ensuring that the seals are free from debris and leaks.
- Ensure Tank Shut-Offs are opened.

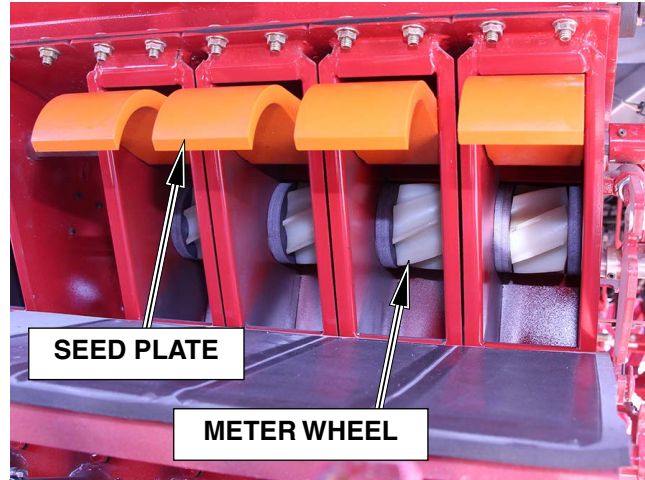

Ensure Metering is Free of Debris

Important

Seed Plate Adjustment

Ensure that when the adjustment handle is in the Fine position notch that the seed plates are tight up against the metering wheels spacers.

If this does not occur adjust the adjustment plate by loosening the bolts that attach the plate to the metering body and slide the plate accordingly.

This adjustment must be done without product in the tank or with the slide gates closed and the metering body cleaned out.

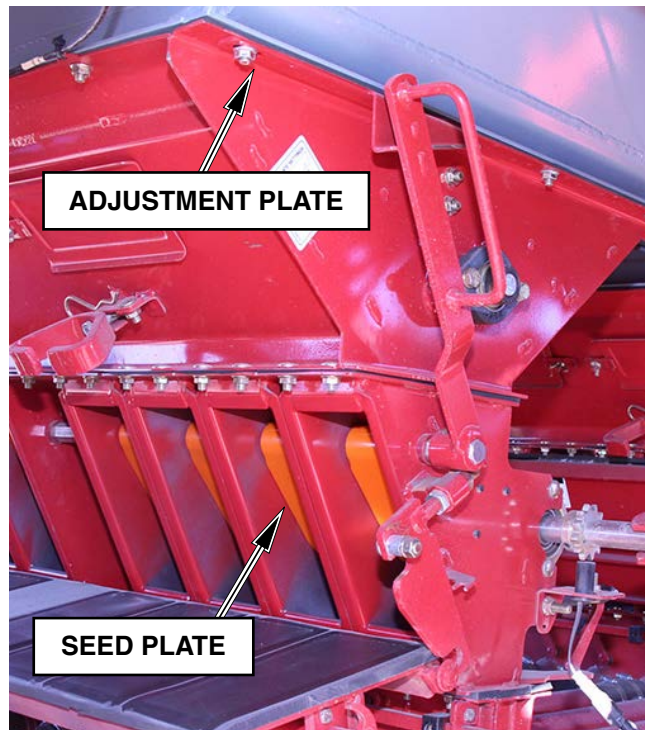

Bin Level Adjustment

- Adjust bin level sensor to desired alarm point.
 - Top position for large seeds, high rates of fertilizer.
 - Middle position for cereal grains.
 - Lower position for fine seeds.



Full Bin Indicator

The Morris 9 Series Air Cart is equipped with an optional fill indicator to alert when bins are full.

Sensor position in tank can be adjusted by loosening U-Bolts and moving up or down on ladder.

- On some tractor models the tractor working lights need to be on in order to have power at the auger switch box - check by turning auger lights on.
- Turn fill switch to on position during filling.
- The appropriate light will illuminate when bin is full.
- Turn off while seeding.

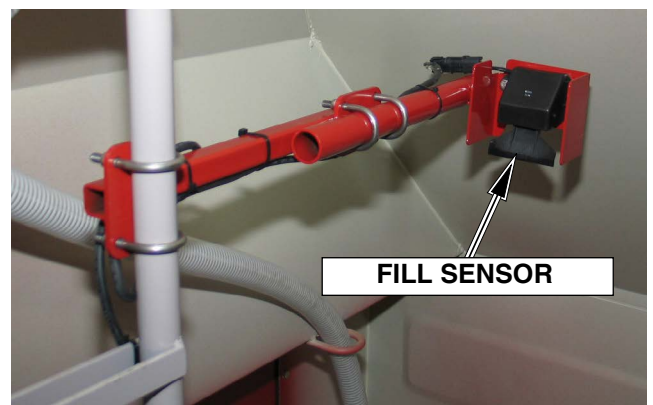
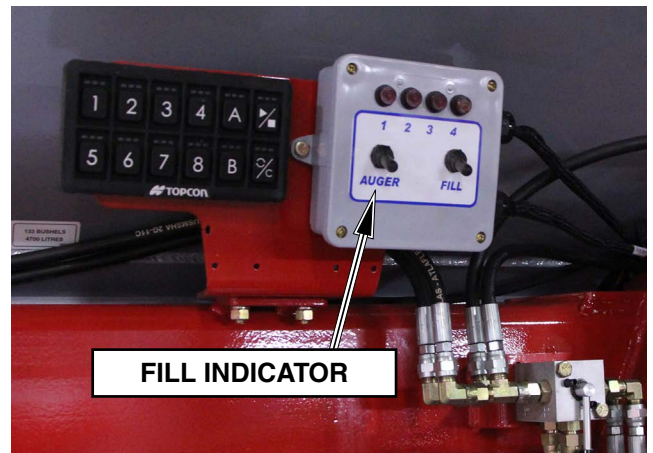

Fill Sensor

Operation

Digi-Star Weigh Scale

The Morris 9 Series Air Cart can be equipped with an optional Digi-Star Weigh Scale to track product usage.

Refer to the Digi-Star manual for setting and operating the scale.

The Digi-Star system requires the following numbers listed below to get the best feedback from the system - for the load cell setups utilized.

Calibration Number

All Tow Between units - 46584

9650 Tow Behind - 62107

9800 / 91000 Tow Behind units - 62111

Setup Number

9650 Tow Behind / Tow Between - 147060

9800 Tow Behind / Tow Between - 147080

91000 Tow Behind - 147090

Note: The last three numbers represent the maximum weight that the system is measuring. Therefore for 147060 - it is weighing a max of 60,000 lbs.

This can be changed to whatever maximum the operator wants - but as the total capacity increases sensitivity increments decrease.



Digi-Star Weigh Scale

Hydraulic Assist Conveyor/Auger

Remote Controller Operation

- Familiarize yourself with the remote functions.
- On initial startup of the system the remote needs to learn the transmitter signal of the solenoid by:
 1. Power up the solenoids Receiver located on Air Cart frame by turning on Tractor or unplugging and plugging in the receiver. This opens a 20 second registration window in the Receiver processor. If looking at the Receiver the Fault LED will be flashing.
 2. Immediately PRESS and HOLD the Controller's Reset Button then within 2 seconds PRESS and HOLD the F1 Button, continue to hold BOTH BUTTONS for a MINIMUM of 5 seconds during this 20 second window. When the Transmitter is Registered the Receiver Fault LED will be illuminated for 3 seconds.

Note: Red light will flash on control box located on Cart frame when any arrow button is pressed indicating it is communicating with the remote controller.

Note: The remote will need to learn the transmitter signal each season of use and when batteries are replaced.

Operation

- Familiarize yourself with the remote functions.
- Ensure selector valve is in correct position for auger operation and engage tractor hydraulics.
- Press round green button to turn controller On.
- Press round red button to turn controller Off.
- Green arrows control inner arm.
- Blue arrows control outer arm.
- Red arrows control lift and lower.
- Store remote controller in tractor cab.

Note: The valve block has a restrictor valve to prevent excessively quick movement of the arms. If arms move rapidly hydraulic flow from tractor is reversed.



Remote Control

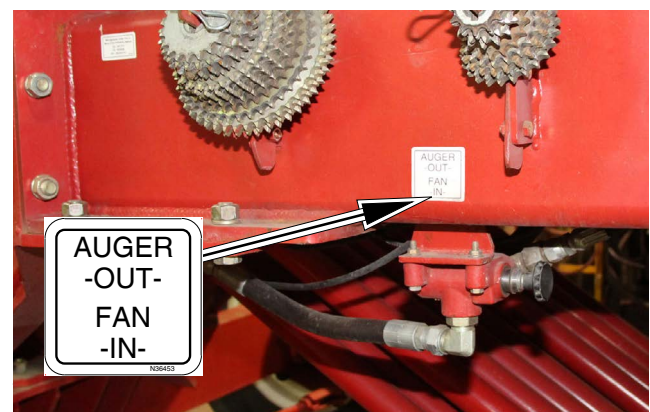

Selector Valve



Operation

Auger

Manual Arms

Available only with standard hopper.

- Ensure lock pin is unlocked to allow free movement of the inner arm.
- Unlatch front cradle lock.
- Lift auger out of front cradle and pull away from cart.
- Refer to decal on frame for inner arm positions.
- Move inner arm to desired slot position by either pulling on auger or pushing on inner arm itself.
- Engage inner arm lock pin into slot for the tank to be loaded/unloaded.
- Complete auger positioning by swinging outer arm and auger into place as required.
- To place auger into storage position. Disengage lock pin, swing inner arm back to slot #1 and relock pin.
- Swing outer arm back fully toward cart.
- Lift auger until it contacts rear rest and swing front end into cradle.
- Latch front cradle lock before transporting.



Manual Auger - Lock Pin

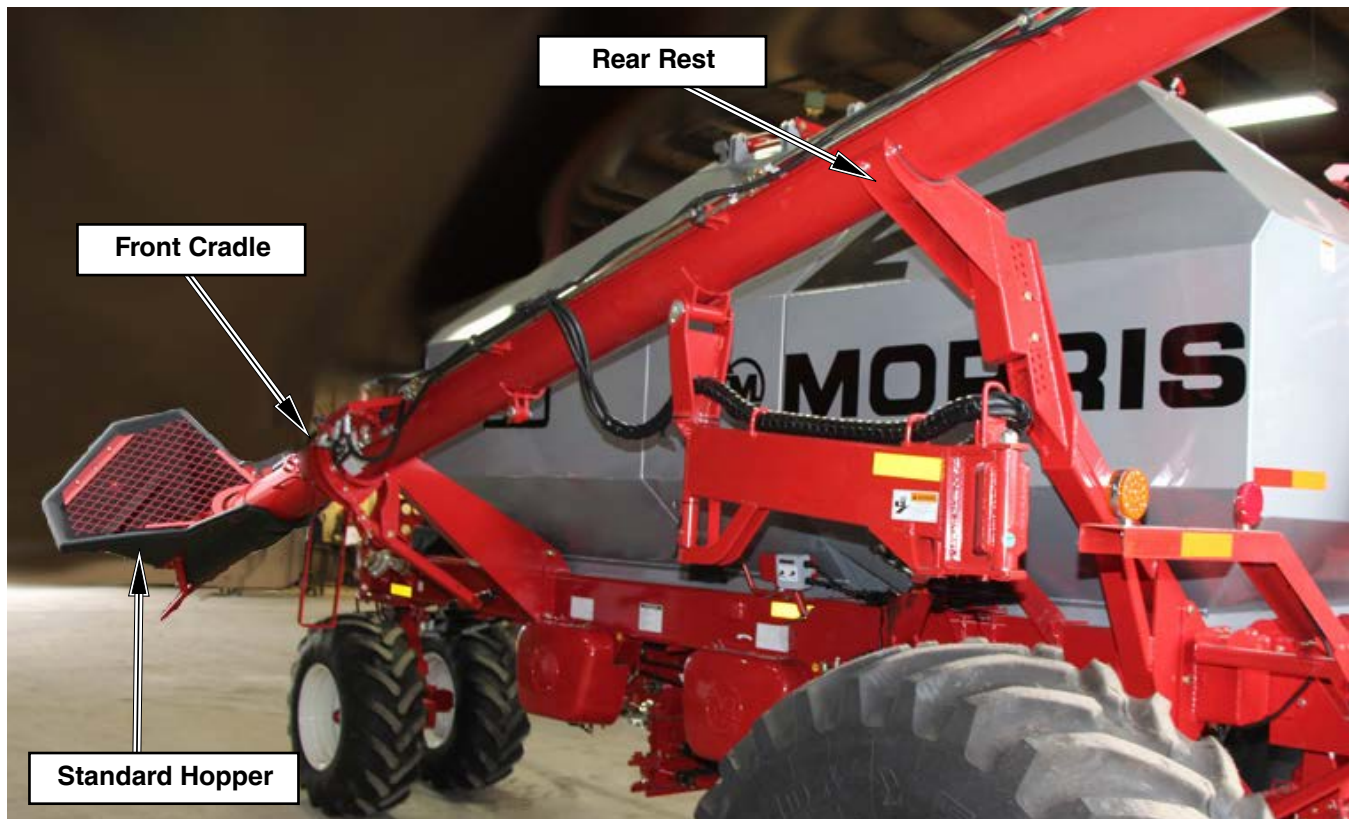

Auger - Continued

Hydraulic Assisted Arms

- Ensure Fan/Auger selector valve is in correct position for auger operation and engage tractor hydraulics.
- Unlatch front cradle lock. Keep head and upper body clear of pad and cradle handle movement.
- Swing out the auger using controller to extend/retract cylinders as required. See “Remote Controller Operation” for details.

Note: The valve block has a restrictor valve to prevent excessively quick movement of the arms. If arms move rapidly hydraulic flow from tractor is reversed.

- Whether filling or dumping tanks, start by positioning inner arm then move outer arm as required. Refer to “Semi Trailer Filling Positions” for approximate auger arm positions (Conveyor shown).
- All tanks can be filled from a central hopper location. Keeping hopper anchored move both arms in small increments from one tank to the next.

Auger Storage Position

- Swing auger into storage position using remote control to extend/retract cylinders as required.
- Refer to “Semi Trailer Filling Positions” (Conveyor shown).

Note: Auger system does not have Lock/Unlock selector valve.

- Manually lock front cradle before transporting.

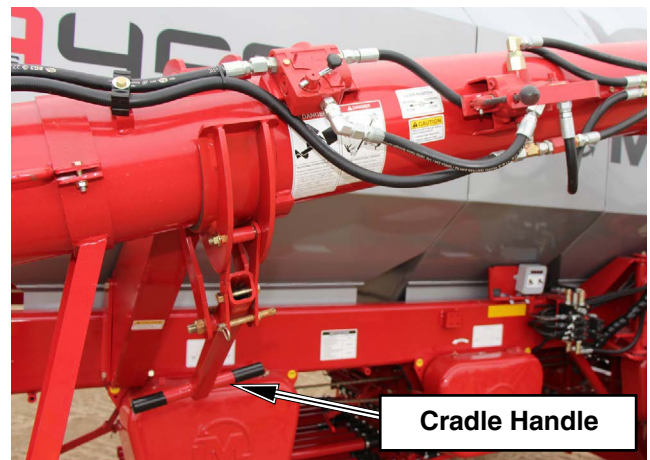

Front Cradle



Remote Control

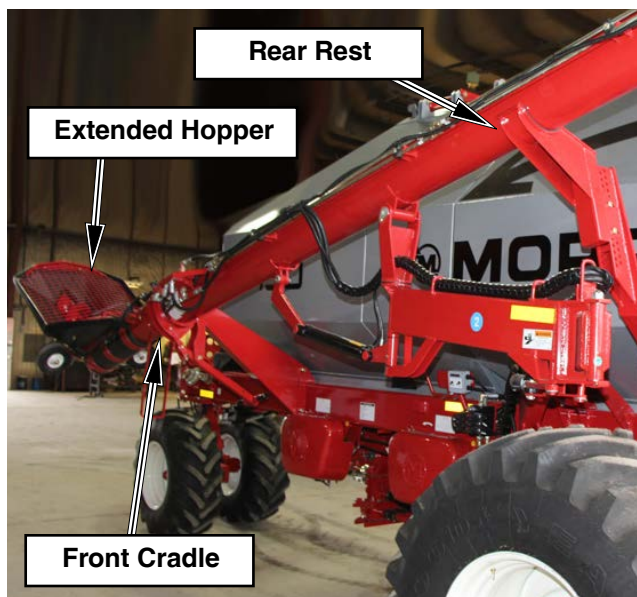

WARNING

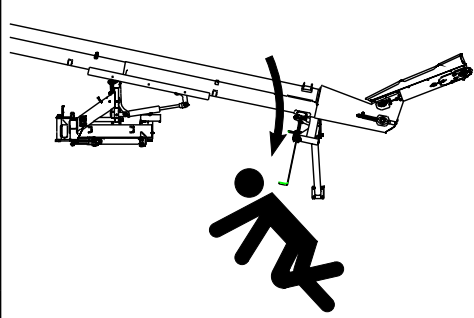

OVERHEAD HAZARD

To prevent serious injury or death:

- Ensure lift cylinder is fully extended before unlatching Auger/Conveyor.
- Stay clear of cradle pad when locking and unlocking.
- Keep others away.

N47905

Operation

Auger - Continued

Extension Hopper

- Hopper flighting speed is controlled by a flow control valve shown. Flow control range is from 0-2 gpm.
- Recommended initial setting is 1 gpm or # 5 on the range scale.
- With auger running, adjust flighting speed as required for smooth feeding of material into main flying. The rpm can be estimated by counting revs for 15 seconds and multiplying by 4, it should be 100 + rpm.

Note: Correct lower auger speed should be between 100 to 120 rpm when valve is set to maximum flow. Excessive hopper flighting speed may reduce main flighting speed noticeably. Keep hopper flighting speed at the minimum required for proper feeding.

- Hopper is supplied with a bottom cleanout door for easy removal of material.

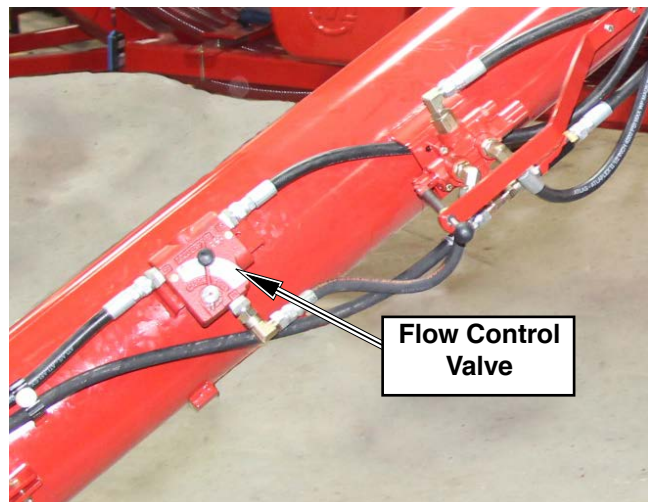

Conveyor

Hydraulic Assisted Arms

- Ensure Fan/Auger selector valve is in correct position for conveyor operation and engage tractor hydraulics.
- Switch conveyor valve to the “Lock/Unlock” position.
- Unlock cradle pads on the conveyor by operating red arrow buttons on remote control.
- Check to ensure both locks are fully released.
- Swing out the conveyor using controller to extend/retract cylinders as required. See “Remote Controller Operation” for details.



Remote Control

Note: The valve block has a restrictor valve to prevent excessively quick movement of the arms. If arms move rapidly hydraulic flow from tractor is reversed.

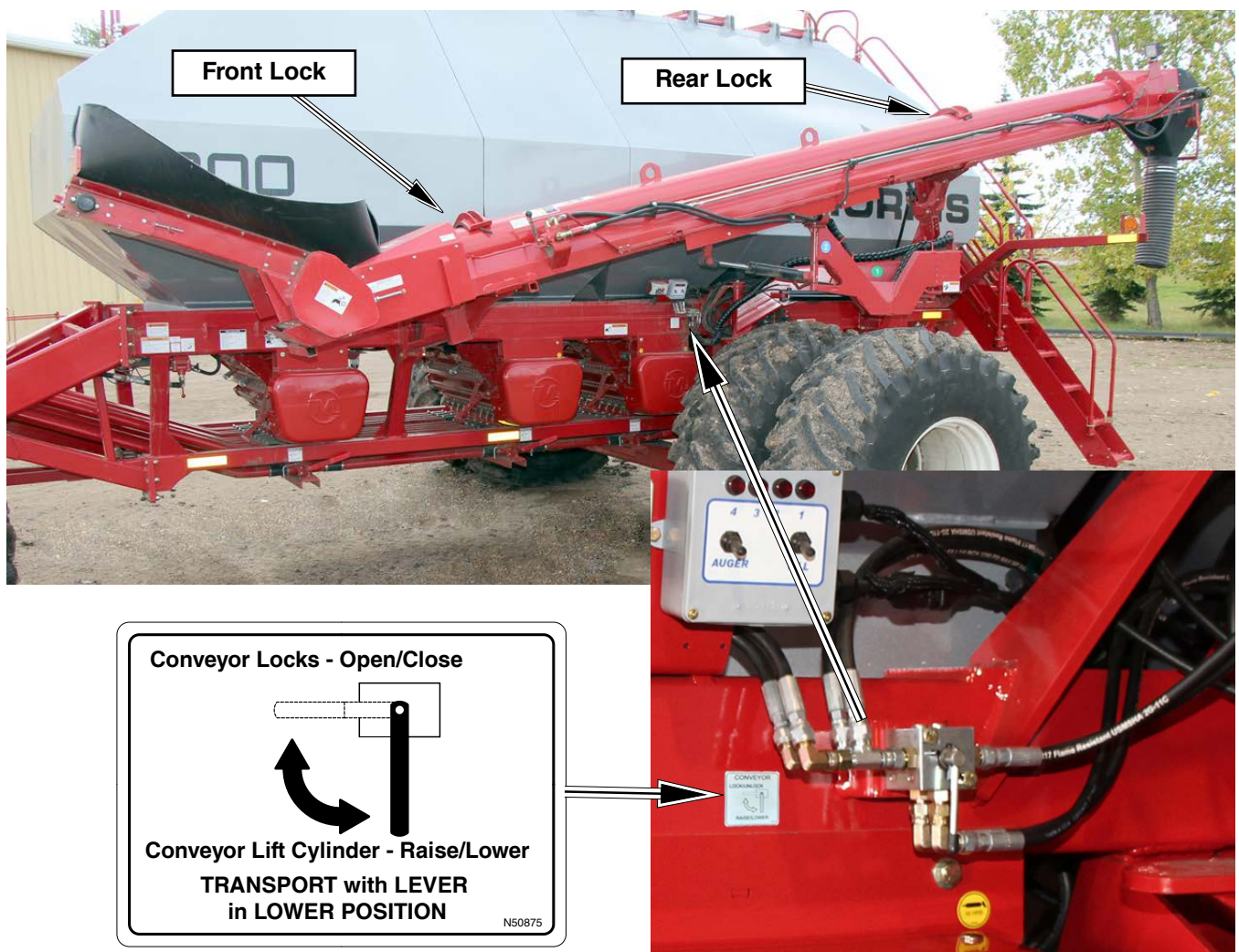

Operation

Conveyor - Continued

- Whether filling or dumping tanks, start by positioning inner arm as indicated then move outer arm as required. Refer to “Semi Trailer Filling Postions” for approximate arm postions.
- All tanks can be filled from a central hopper location. Keeping hopper anchored move both arms in small increments from one tank to the next.

! Danger

Keep all shields in place. Keep hands, feet and clothing away from auger intake, failure to do so will result in serious injury or death.

Conveyor Storage Position

- Swing conveyor into Storage position using remote control to extend/retract cylinders as required. Refer to “Semi Trailer Filling Postions” for approximate arm postions.
- Check to ensure both locks are fully engaged before transporting.

! WARNING

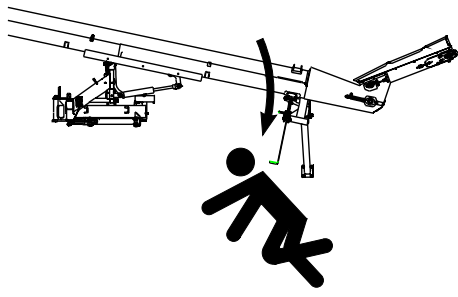

OVERHEAD HAZARD

To prevent serious injury or death:

- Ensure lift cylinder is fully extended before unlatching Auger/Conveyor.
- Stay clear of cradle pad when locking and unlocking.
- Keep others away.

N47905

Conveyor Belt Speed

The conveyor only requires a flow of 10-15 gpm for optimum feed rate. To ensure the belt does not exceed the maximum speed, a Flow Control Valve is incorporated into the hydraulic circuit maintaining 15 gpm of flow to the conveyor when fan speeds are greater than 3500 rpm.

The recommended conveyor belt speed range for optimum feed rate is as follows:

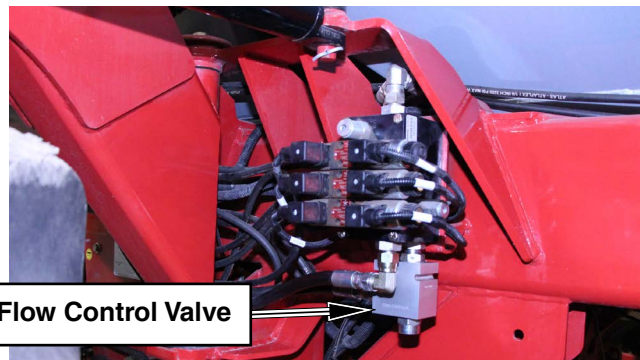

CLEATED BELT SPEED	CLEATED BELT - TIME / REV		CORRESPONDING FAN SPEED	HYRAULIC FLOW
	23FT	25FT		
Minimum 400 FT/MIN	7 SEC	8 SEC	2400 RPM	10 GPM
Maximum 600 FT/MIN	4.5 SEC	5.5 SEC	3500 RPM	15 GPM

Note: Exceeding the recommended belt speed will reduce product capacity and increase seed damage and may cause hydraulic motor seal failure. Motor Seal Kit Number is N55718.

Conveyor - Continued

Operation

- Set Conveyor Belt Speed before operating. Refer to “Conveyor Belt Speed” for details.
- One person must be in a position to monitor the operation of the conveyor at ALL times. **The operator should be alert to any unusual vibrations or noises that might indicate the need for service or repair during the initial startup and break-in period.**
- For smoother startups, keep the conveyor from starting totally full. This will also ensure efficient operation.
- In cold weather, run empty conveyor for five minutes to warm up belt. Otherwise, do not operate the conveyor empty for long periods of time.
- You must “break-in” the conveyor when it is new and at the beginning of each season. Refer to “**Startup and Break-In**” below.
- Make sure the drive end is empty before shutting down the conveyor.

Be certain to close ALL clean-out and inspection doors in the main conveyor hopper before operating.

The operator should not add power before viewing the entire work area and checking that ALL personnel are clear of the designated work area.

The operator should regulate the grain flow to the main conveyor by controlling the amount of grain fed into the hopper. Avoid plugging the main conveyor by overfeeding the hopper.

Be certain that all safety shields and devices remain in place during operation.

Ensure that hands, feet, and clothing are kept away from moving parts.

Stop the engine and lockout the power source whenever the equipment must be serviced or adjusted.

Startup and Break-In

- A. Any conveyor that is new or has set idle for a season needs to go through a “break-in” period.
- B. Engage the Conveyor at a slow RPM to minimize shock loads.
- C. Do not allow the conveyor belt to “load up” at a low speed. If this occurs, high torque must be used to turn the belt and this can damage the conveyor.
- D. Run the conveyor at partial capacity until several hundred bushels of grain have been conveyed and the belt and tube are polished.
- E. Retighten belt to restore original belt tension.
- F. When the belt and tube are polished and smooth, slowly work up to the recommended speed and run the conveyor at full speed.



Warning

NEVER perform maintenance on the conveyor unless all safety shields are in place.

Replace any that are damaged or lost. Do not clean, adjust, or lubricate any part of the machine.

Operation

Conveyor - Continued

Conveyor Adjustments and Maintenance

Belt Tension/Tracking - Inspect Daily when cleaning out seed/fertilizer

Damage to the belt caused by improper tracking is not covered under warranty.

Adjust tension of 2" cleated belt in conveyor tube to 23 lb-ft torque on idler roller adjustment bolts. Adjust both sides evenly.

Adjust tension of crescent belt in hopper to 50 inch-lbs torque on idler roller adjustment bolts or until center of belt rises off the support underneath it. Adjust both sides evenly.

Check/adjust belt tracking alignment on idler rollers.

1. **Rollers must be square with the housing and parallel to each other to insure proper belt tracking.**

2. Belt Tension must be great enough to prevent slippage. Check tension of the belts before running the conveyor.

3. Run the conveyor. Check to see that the belt runs centered on the drive roller. Turn off the conveyor. Adjust drive roller to be square with the housing if necessary. **Normally, once the drive roller is tracked at the factory it rarely needs adjustment.**



4. To adjust drive roller, loosen the four nuts on the bearing holder plate, and the jam nut on the threaded adjuster. Retighten after adjusting is complete.

5. Run the conveyor for two minutes.

6. Turn the conveyor off and open the Tail End Cleanout Door to view the idler roller. Check to see that the belt is running centered on the idler roller. **There should be approximately 1/2" gap between the housing and the belt on both sides. Rubbing on the side of the housing can cause severe damage to the belt and/or affect filling capacity.**

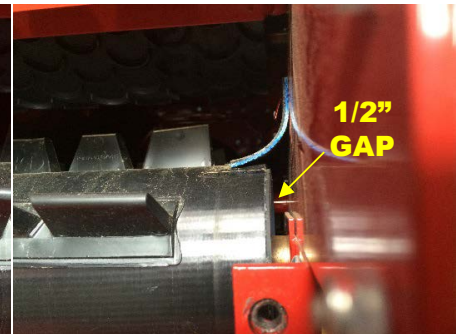
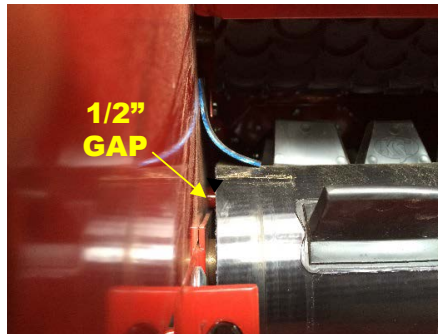

7. If adjustment is necessary, **TIGHTEN** the roller on the side of the housing that the belt is closest to, or rubbing on. Adjust bolt in 2-3 turn increments. Run the conveyor after each adjustment to see the result.



8. Once the belt is centered, run the conveyor for at least two more minutes to insure the belt remains in position.

9. Lock adjustment bolt jam-nuts and reinstall the clean out door.

NOTE: Adjust the tracking on the hopper crescent belt in a similar fashion.

Conveyor - Continued

Cleaning/Inspecting the Conveyor - 8 hours or Daily

- The conveyor tail areas must be inspected and cleaned out before use each day or preferably at the end of the day. This will help prevent material residue from building up, freezing and causing belt damage and/or difficulty driving the belt.
- The conveyor drive end should be inspected and cleaned every 40 hours or weekly for the same reasons.



Access cover and door for hopper clean-out

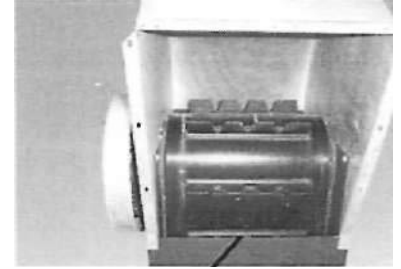

Access cover for drive head cleanout



Access cover for incline conveyor cleanout

Conveyor Belt/Tail End Care

- It is **highly recommended** that both conveyor belts be washed off and the entire tail end be cleaned out at the end of the season.
- This will help prevent material residue from building up and causing rust/paint and/or belt damage.
- In order for water to drain from the lower crescent belt, position the splice on the top side by running and then stopping the conveyor when the splice appears in the hopper.
- **WHEN CLEANING, INSURE ALL HARDENED OR STUCK-ON MATERIAL IS REMOVED.**

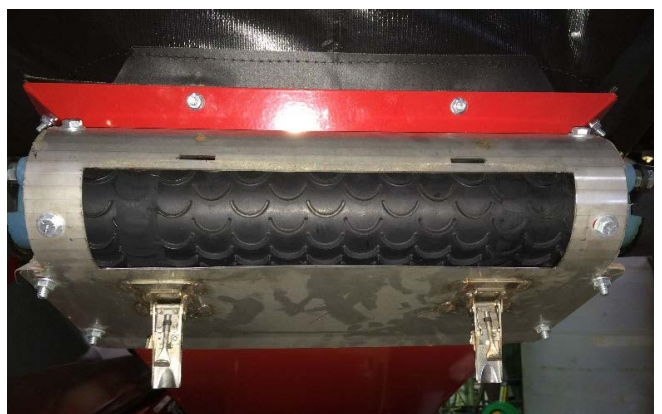

Operation

Semi Trailer Filling Positions

Below is a typical filling sequence from a semi trailer. Due to variations in trailers this procedure may vary.

NOTE:RECOMMENDED MOVEMENT IS SHOWN BY THE BOLD ARROWS. MINIMUM ARM MOVEMENT WILL SIMPLIFY THE OPERATION. ANGLE DIMENSIONS ARE SHOWN FOR RELATIVE MOVEMENT REFERENCE ONLY. VALUES MAY VARY.

FILLING SEQUENCE

STEP 1

- POSITION TRAILER APPROX 13-14FT FROM AIR CART FRAME RAIL (MAY VARY)
- POSITION TRAILER FRONT CHUTE APPROX IN LINE WITH CENTER OF TANK OPENINGS
- SET SELECTOR VALVE TO CONVEYOR LOCK/UNLOCK
- RELEASE LOCKS WITH LIFT/LOWER BUTTONS ON REMOTE

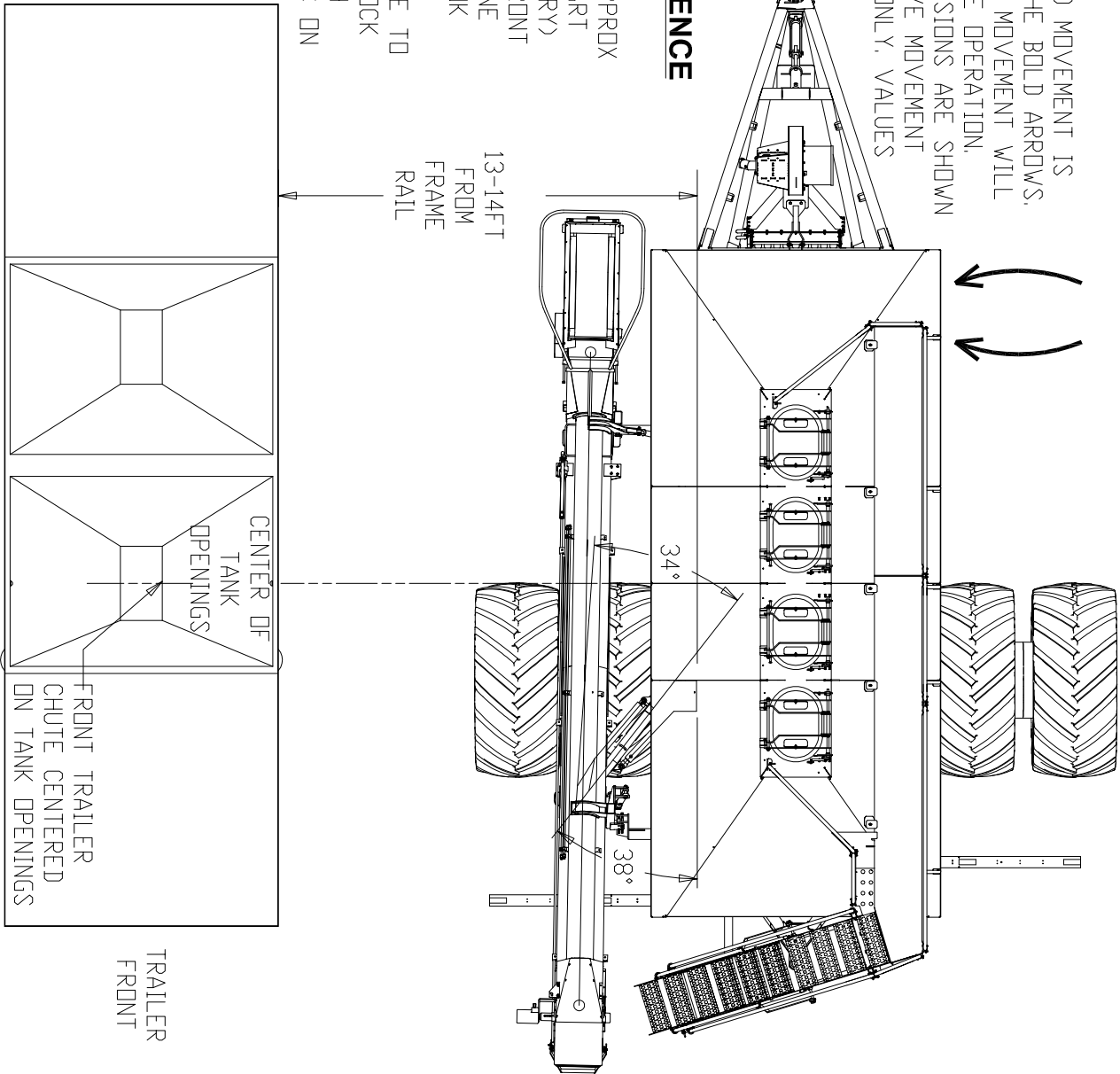

Semi Trailer Filling Positions - Continued

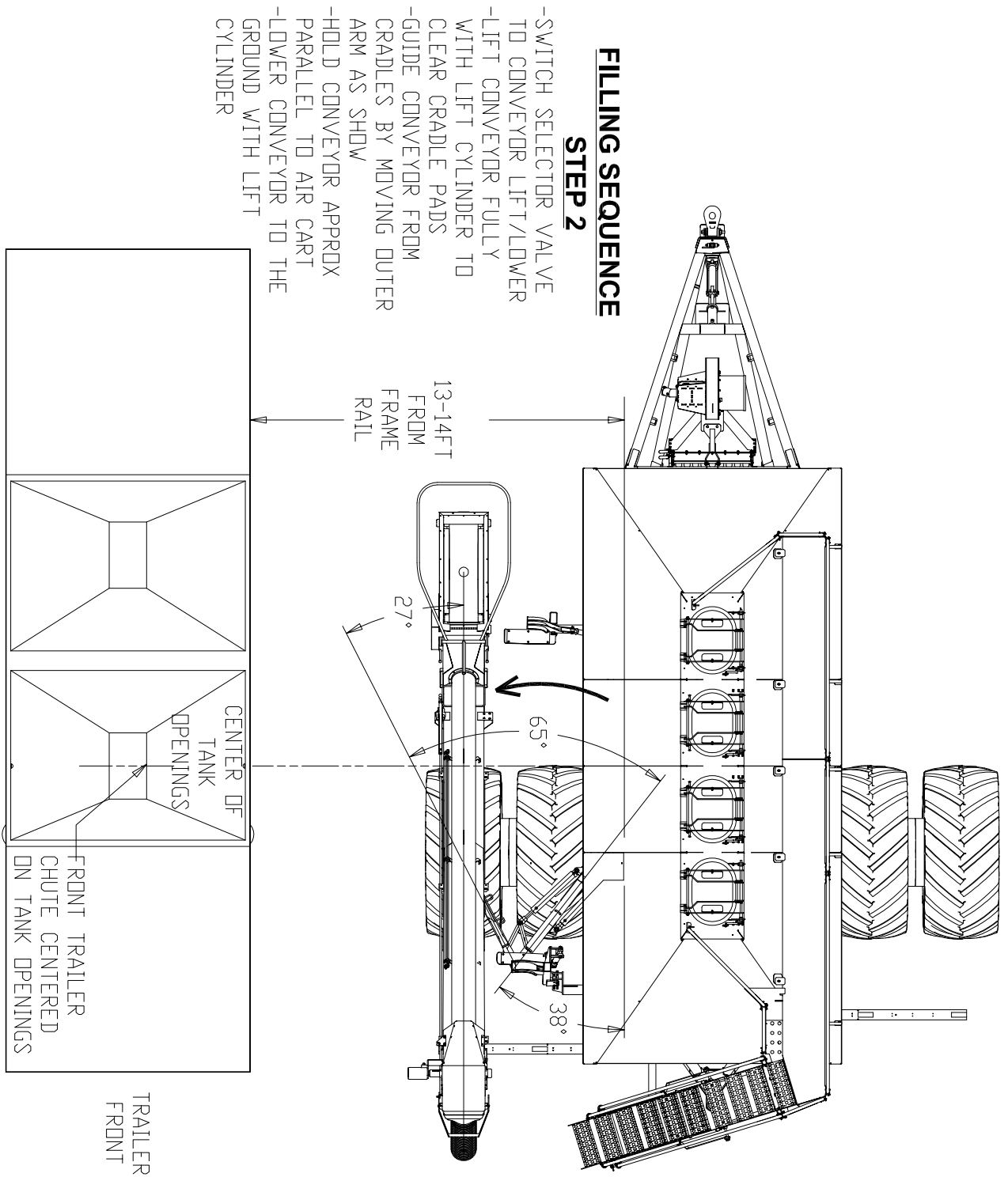

Operation

Semi Trailer Filling Positions - Continued

FILLING SEQUENCE

STEP 3

- LIFT WEIGHT OF CONVEYOR JUST OFF THE GROUND WITH LIFT CYLINDER
- MANUALLY SWING CONVEYOR UNDER TRAILER AND TOWARD FRONT CHUTE AS CLOSE AS POSSIBLE
- ARMS REMAIN UNMOVED

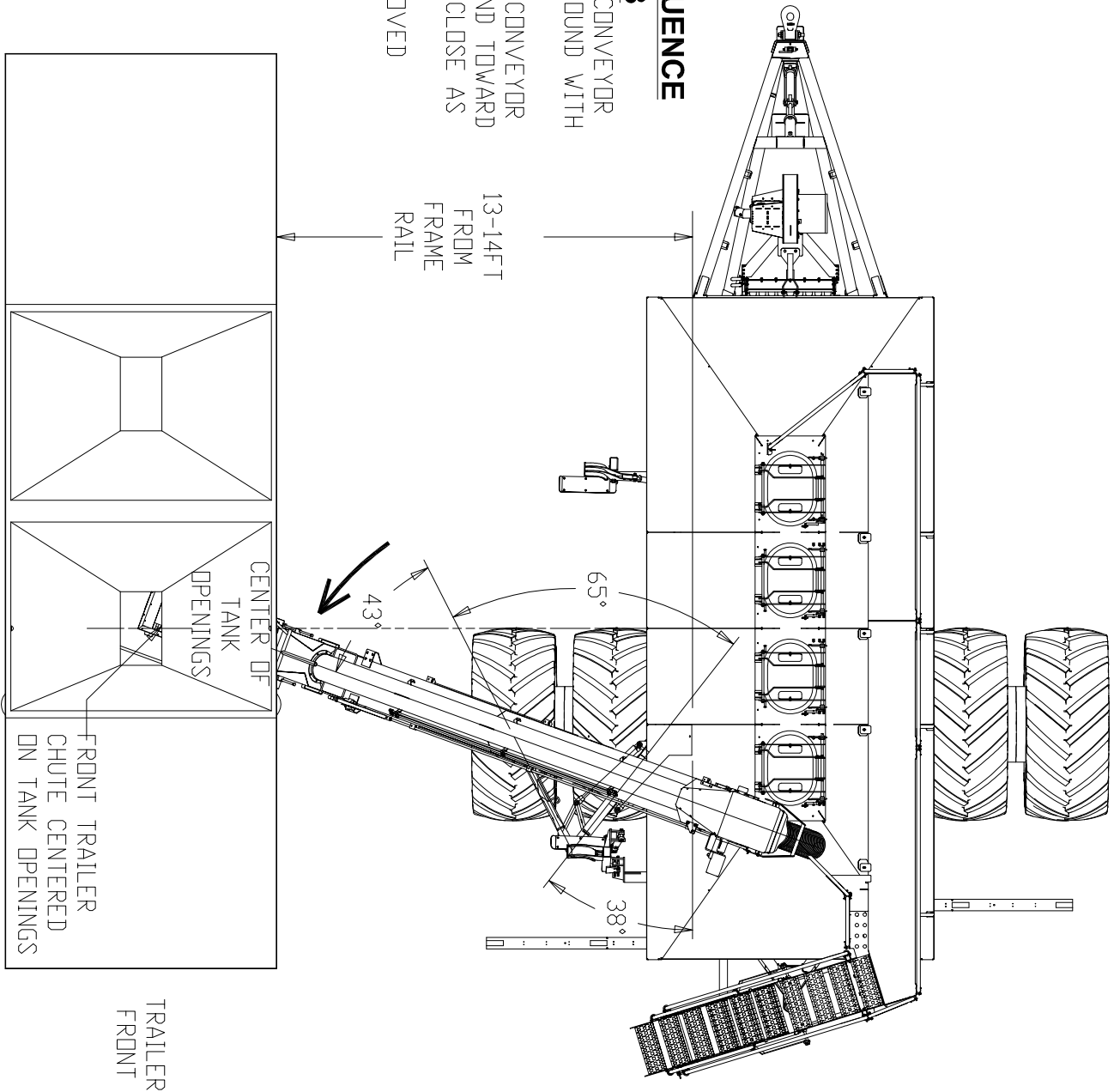

Semi Trailer Filling Positions - Continued

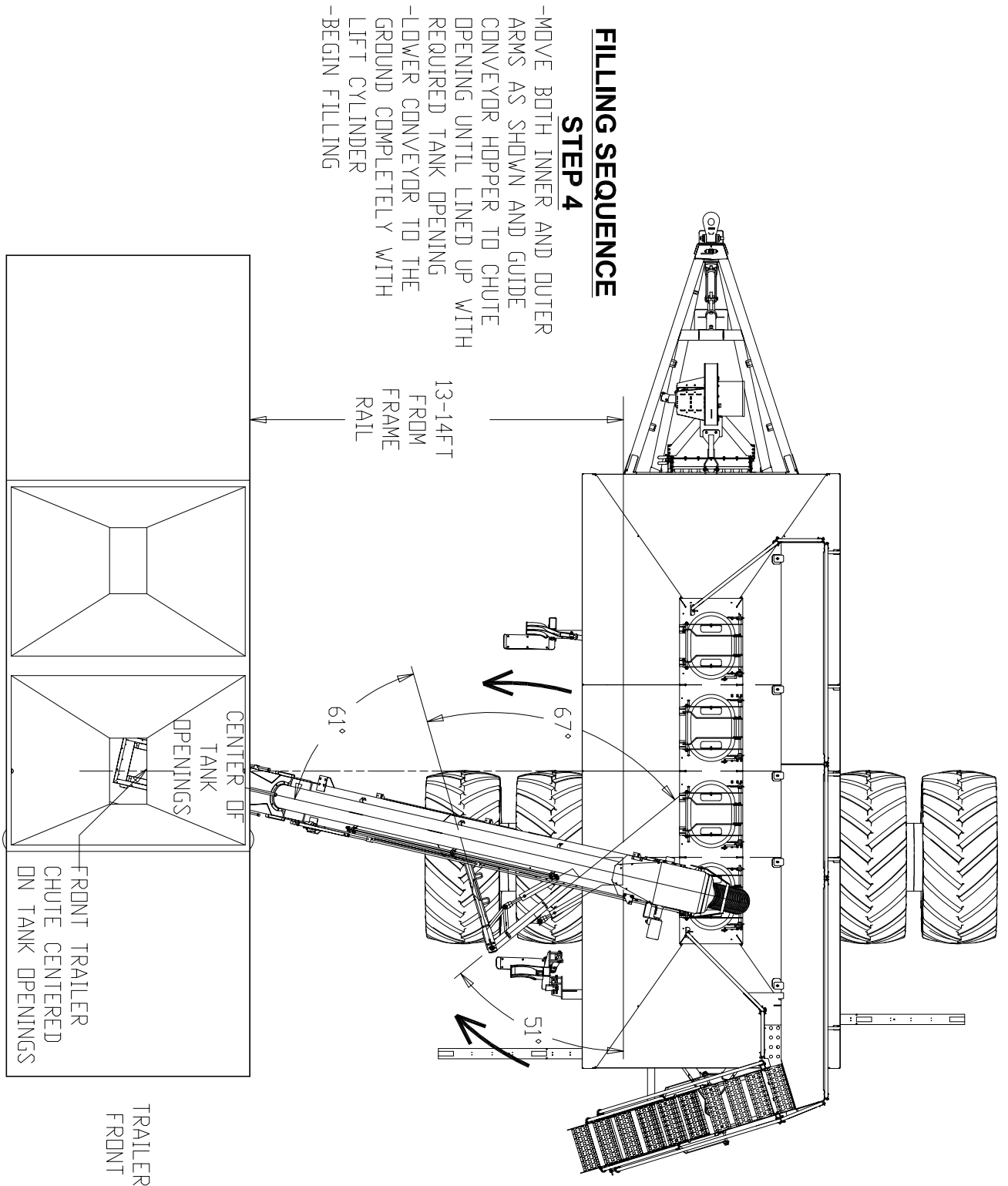

Operation

Semi Trailer Filling Positions - Continued

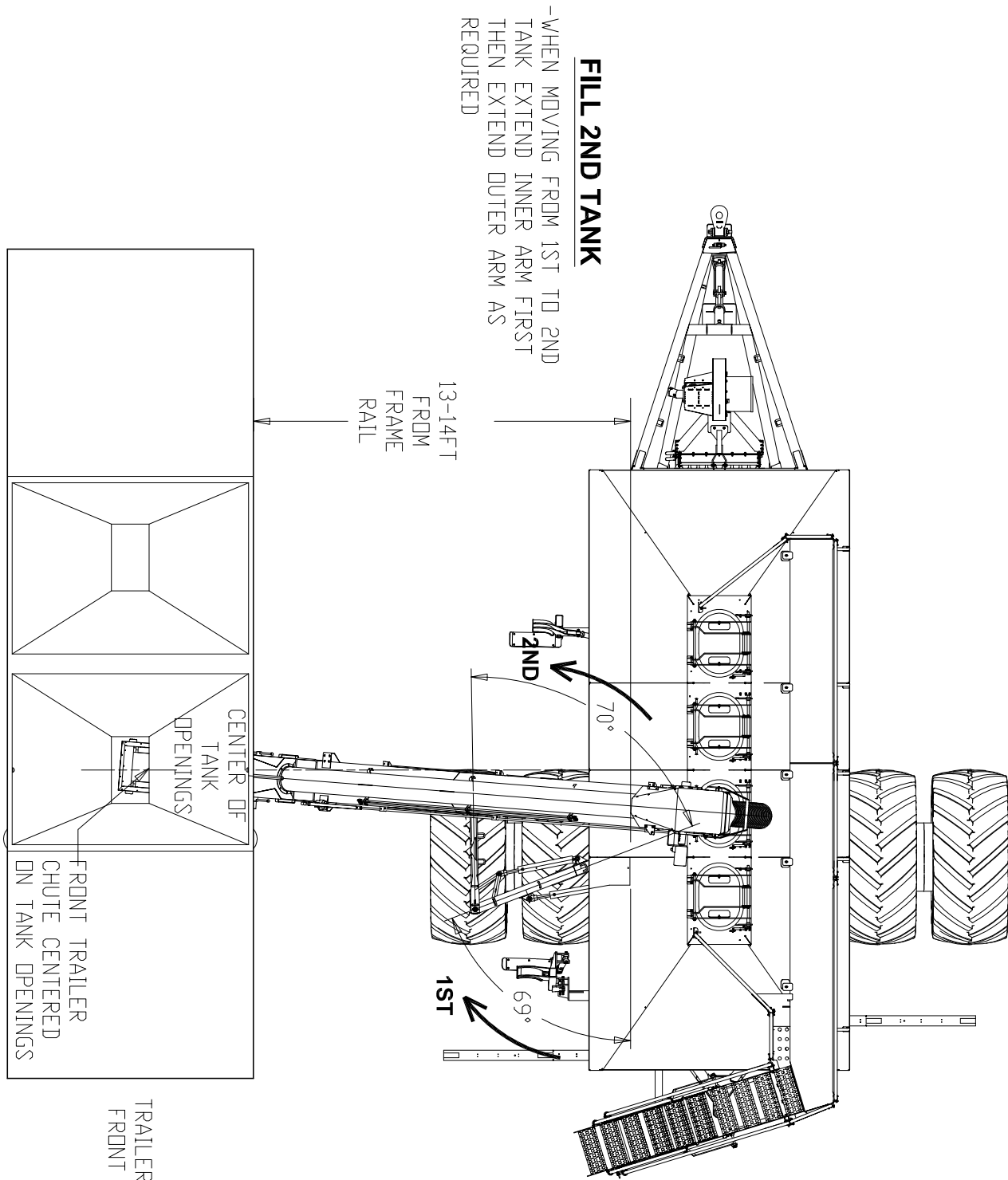

Semi Trailer Filling Positions - Continued

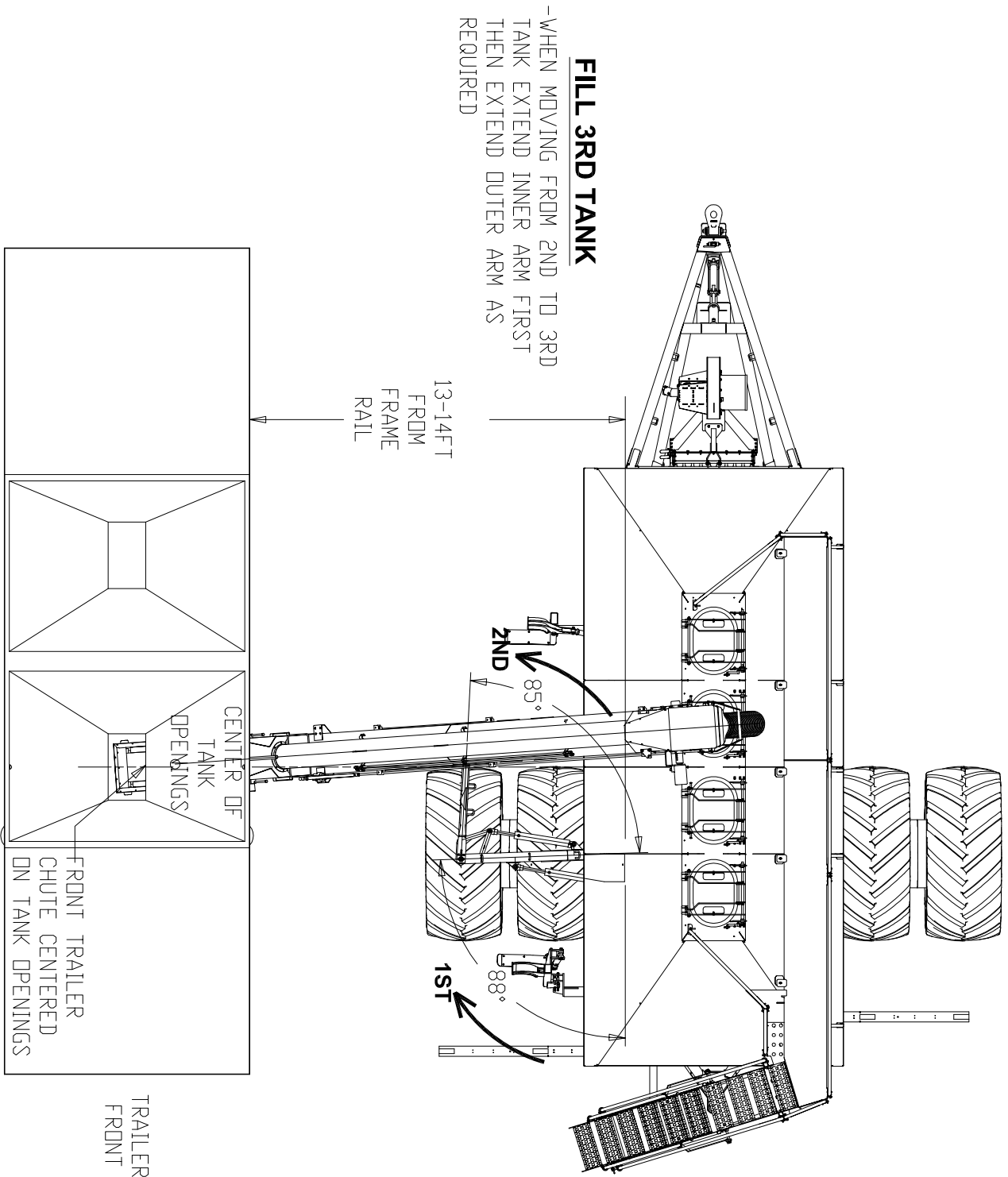

Operation

Semi Trailer Filling Positions - Continued

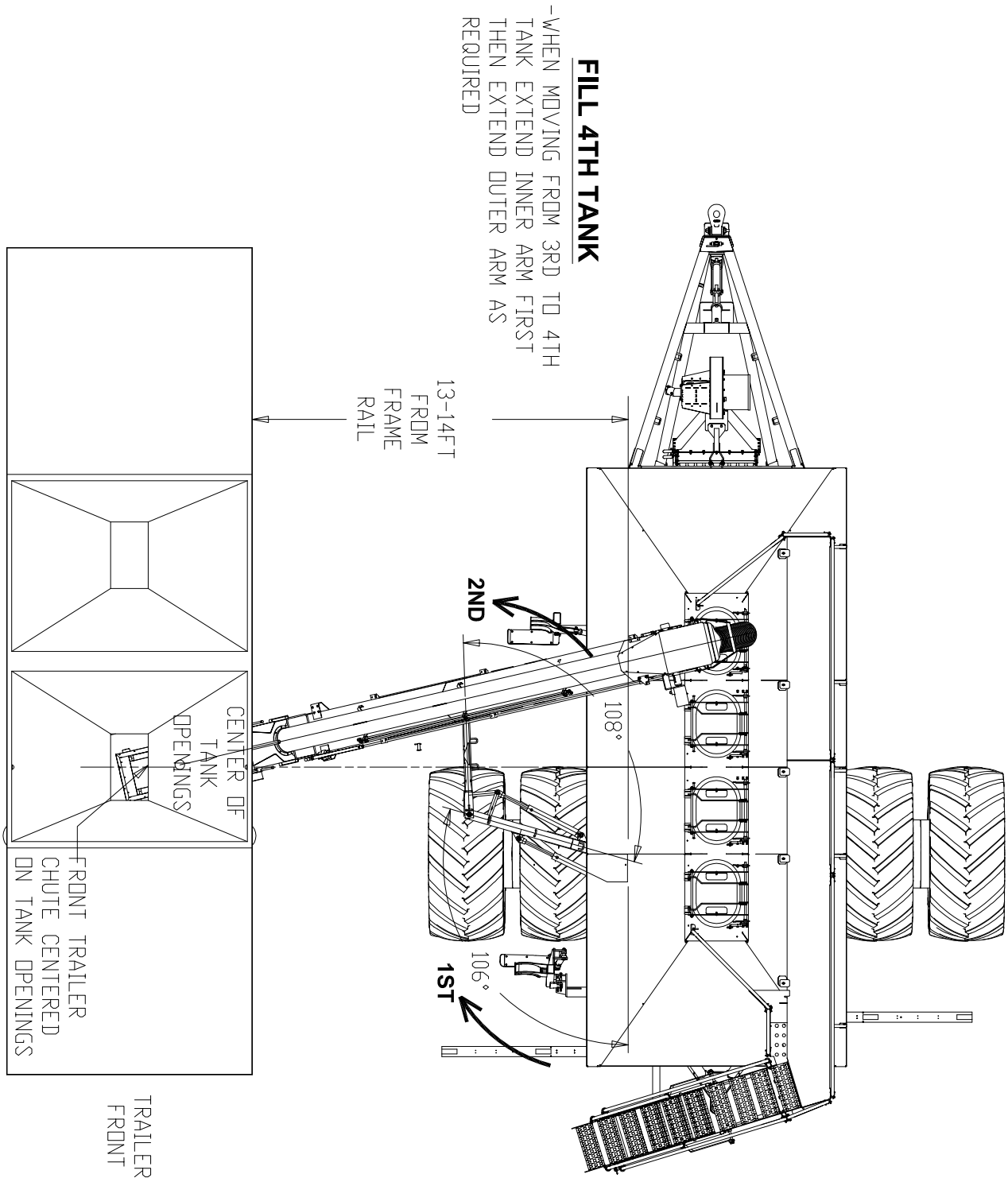

Semi Trailer Filling Positions - Continued

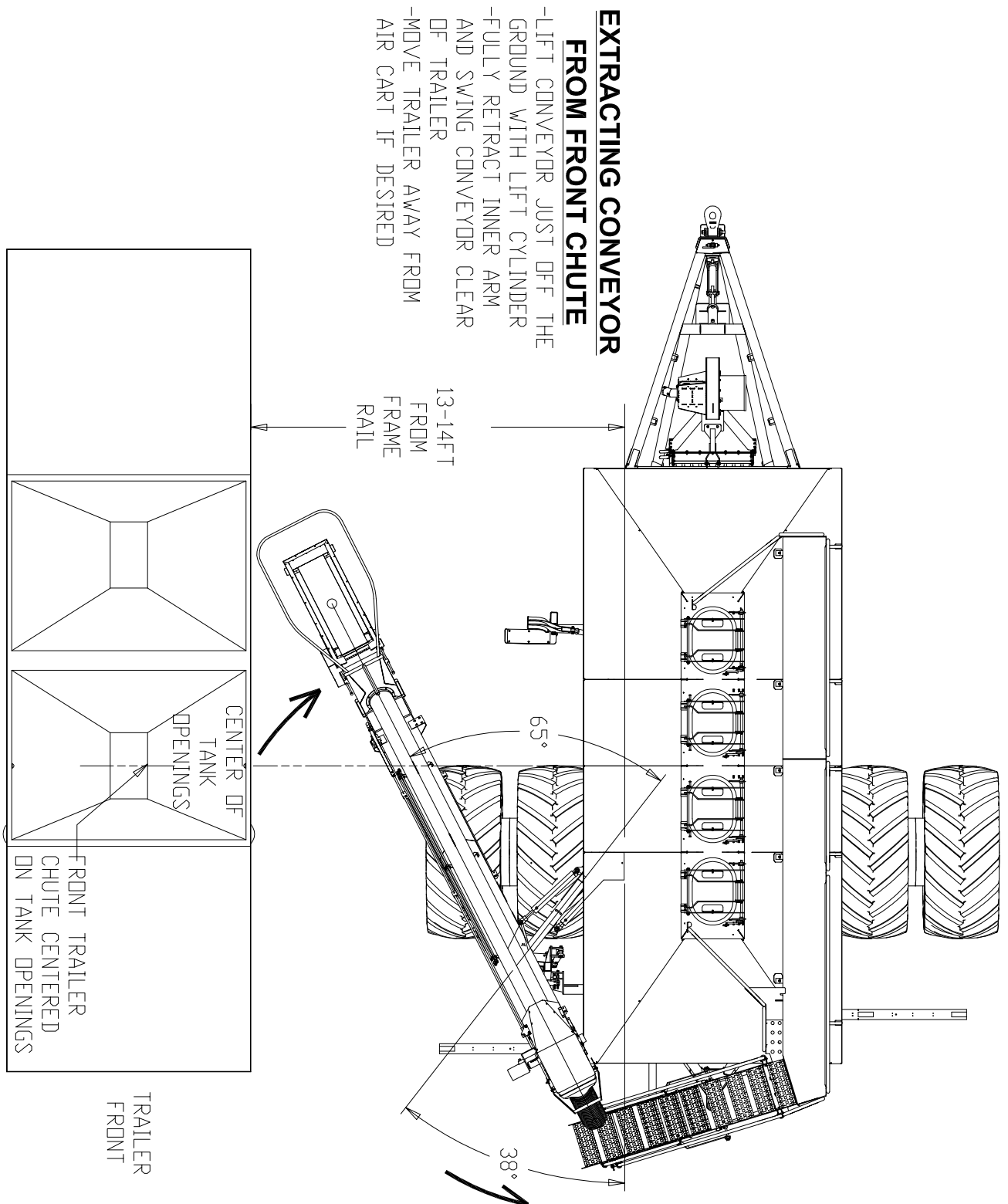

Operation

Semi Trailer Filling Positions - Continued

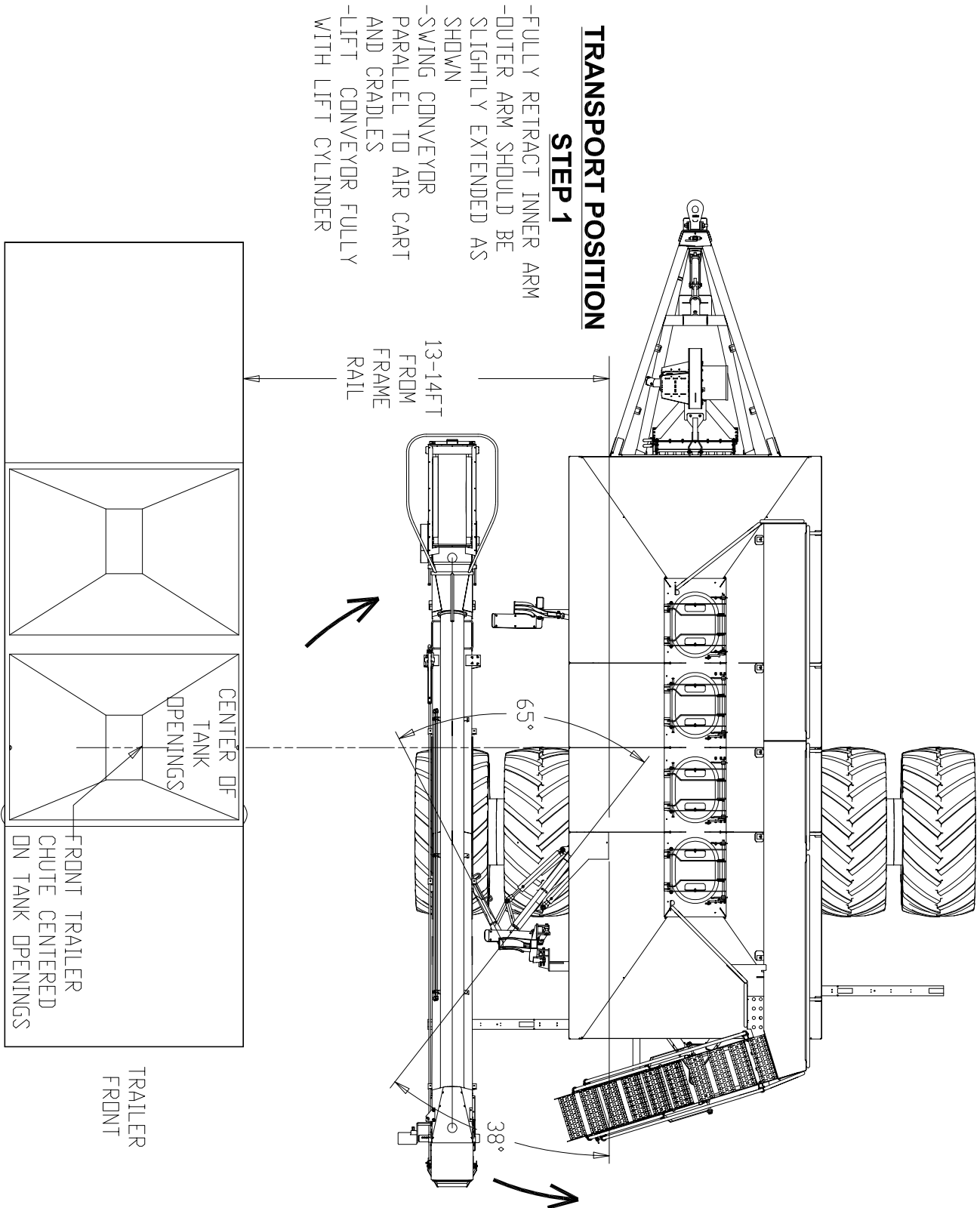

Semi Trailer Filling Positions - Continued

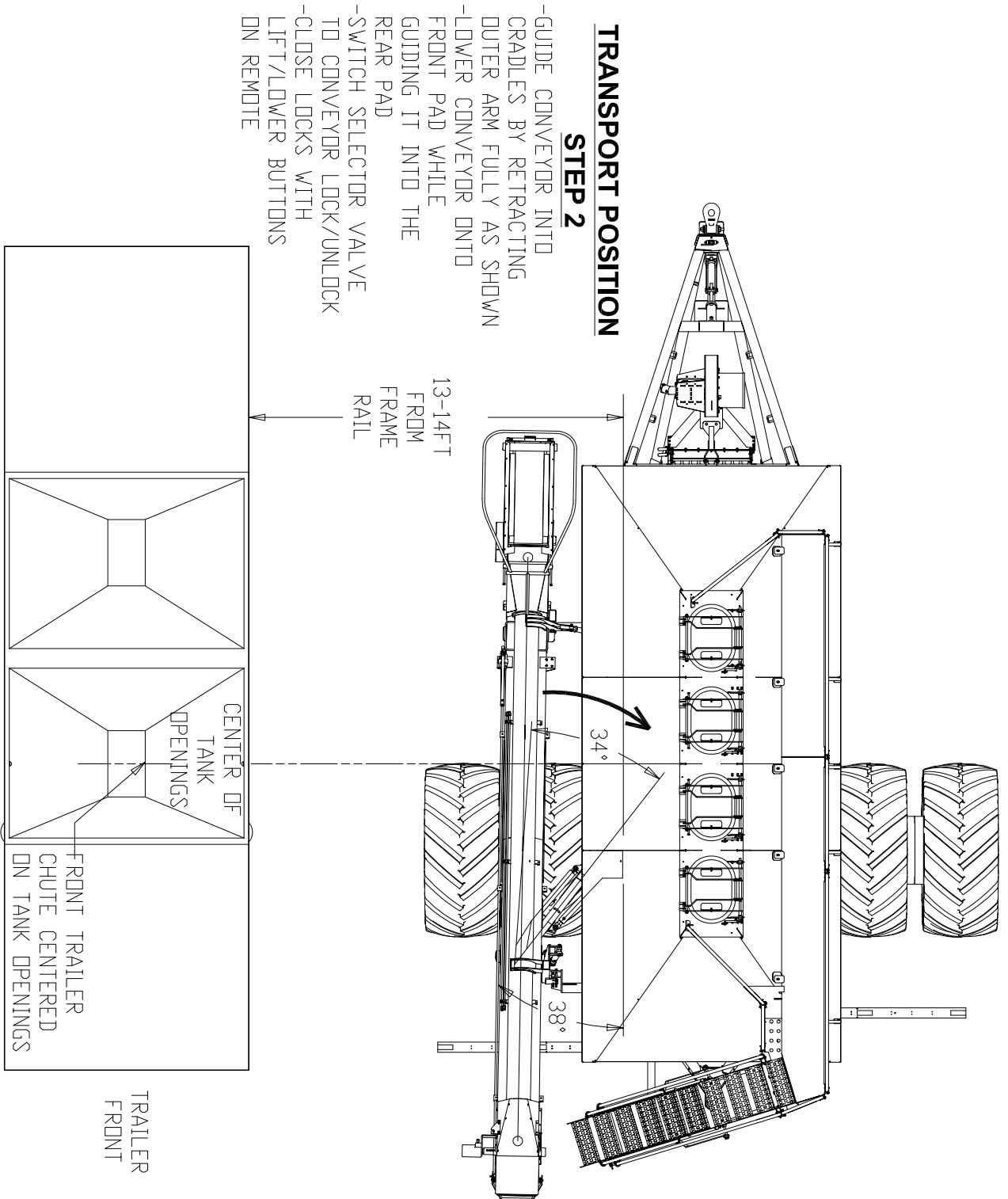

Operation

Semi Trailer Filling Positions - Continued

MOVING FROM FRONT TO REAR CHUTE

STEP 1

-LIFT CONVEYOR JUST OFF THE GROUND WITH LIFT CYLINDER -FOR THE SAKE OF SAFETY IT IS ADVISABLE TO RETRACT THE CONVEYOR SLIGHTLY AS SHOWN TO INSURE CLEARANCE BETWEEN CONVEYOR AND CHUTES, ETC

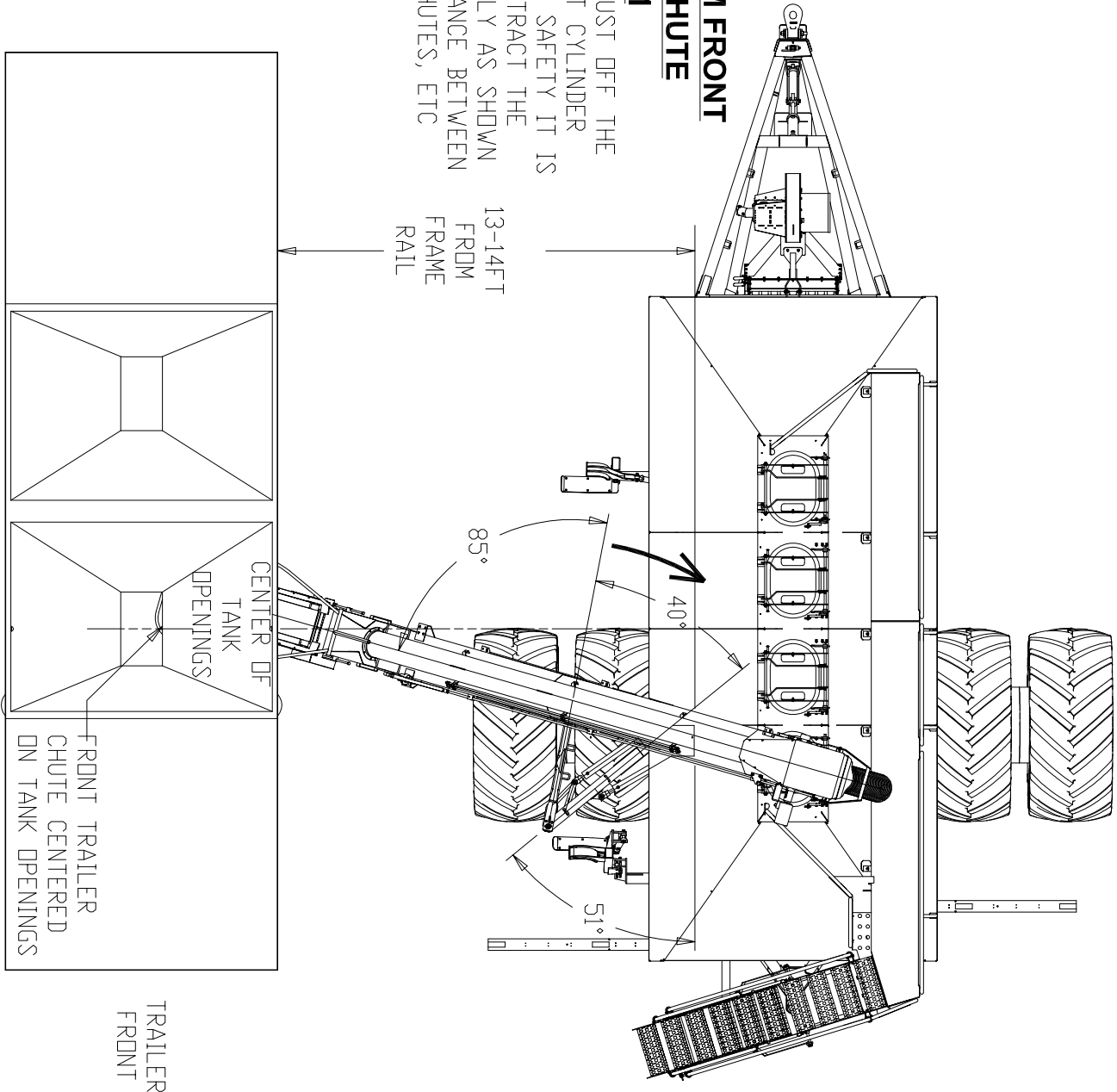

Semi Trailer Filling Positions - Continued

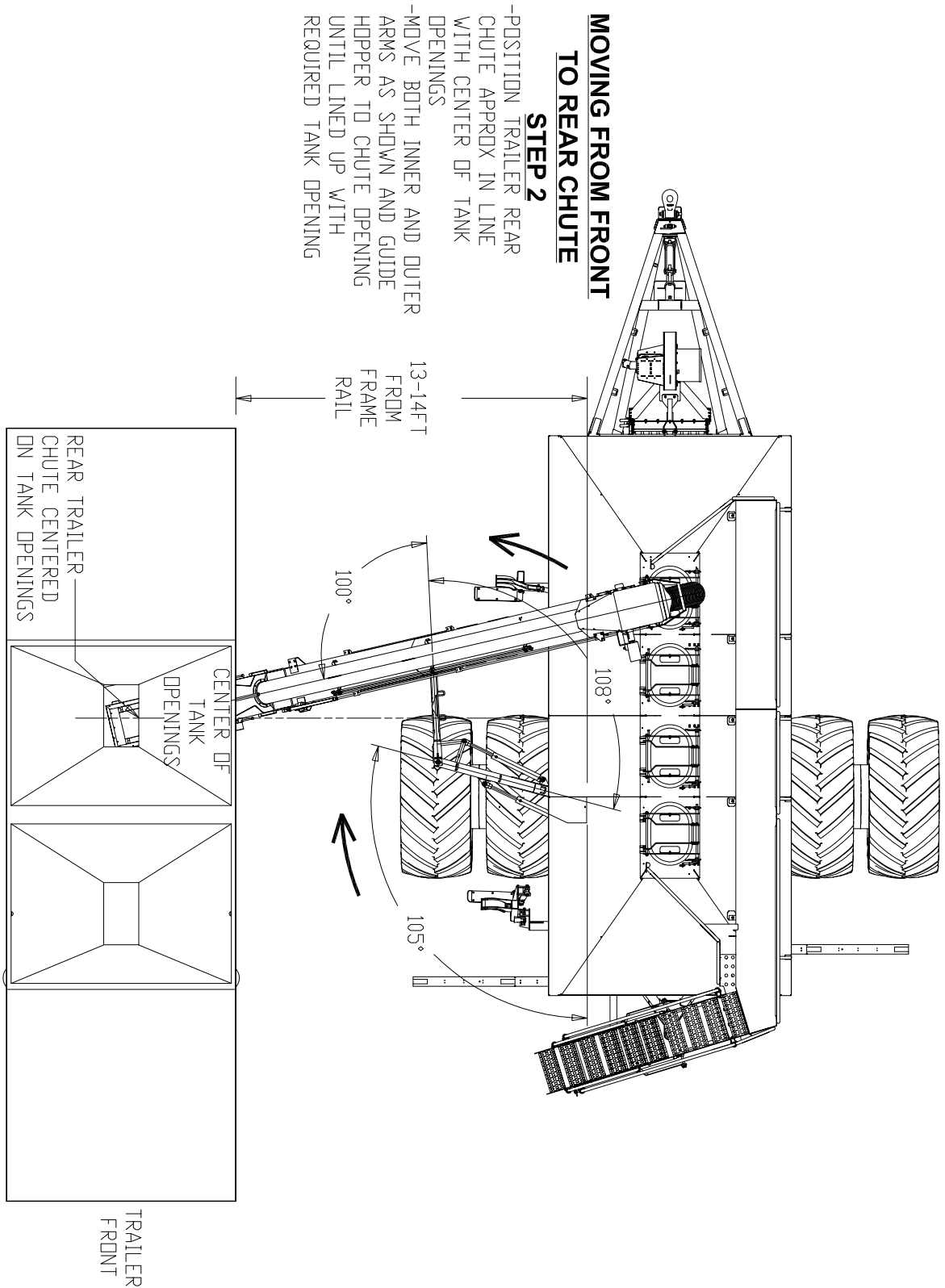

Operation

Semi Trailer Filling Positions - Continued

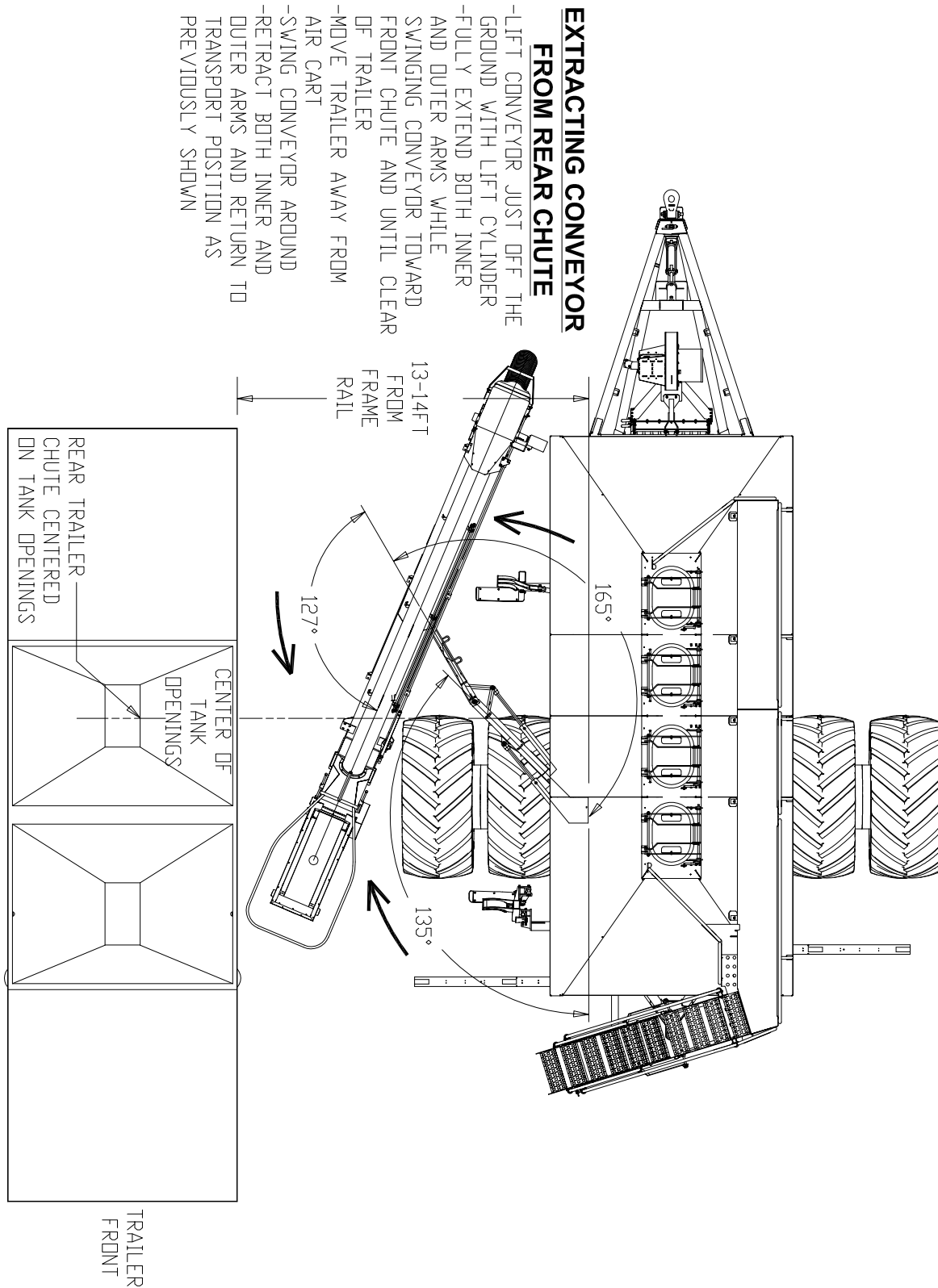

Semi Trailer Dump Positions

DUMP REAR TANK

- TO DUMP REAR TANK ON TOW BETWEEN MODELS CONVEYOR MUST BE SWUNG AROUND BEHIND WHEELS AND IN FRONT OF LIGHT BRACKET
- CONVEYOR MUST BE MOVED UNDER AIR CART BEFORE TRAILER IS POSITIONED

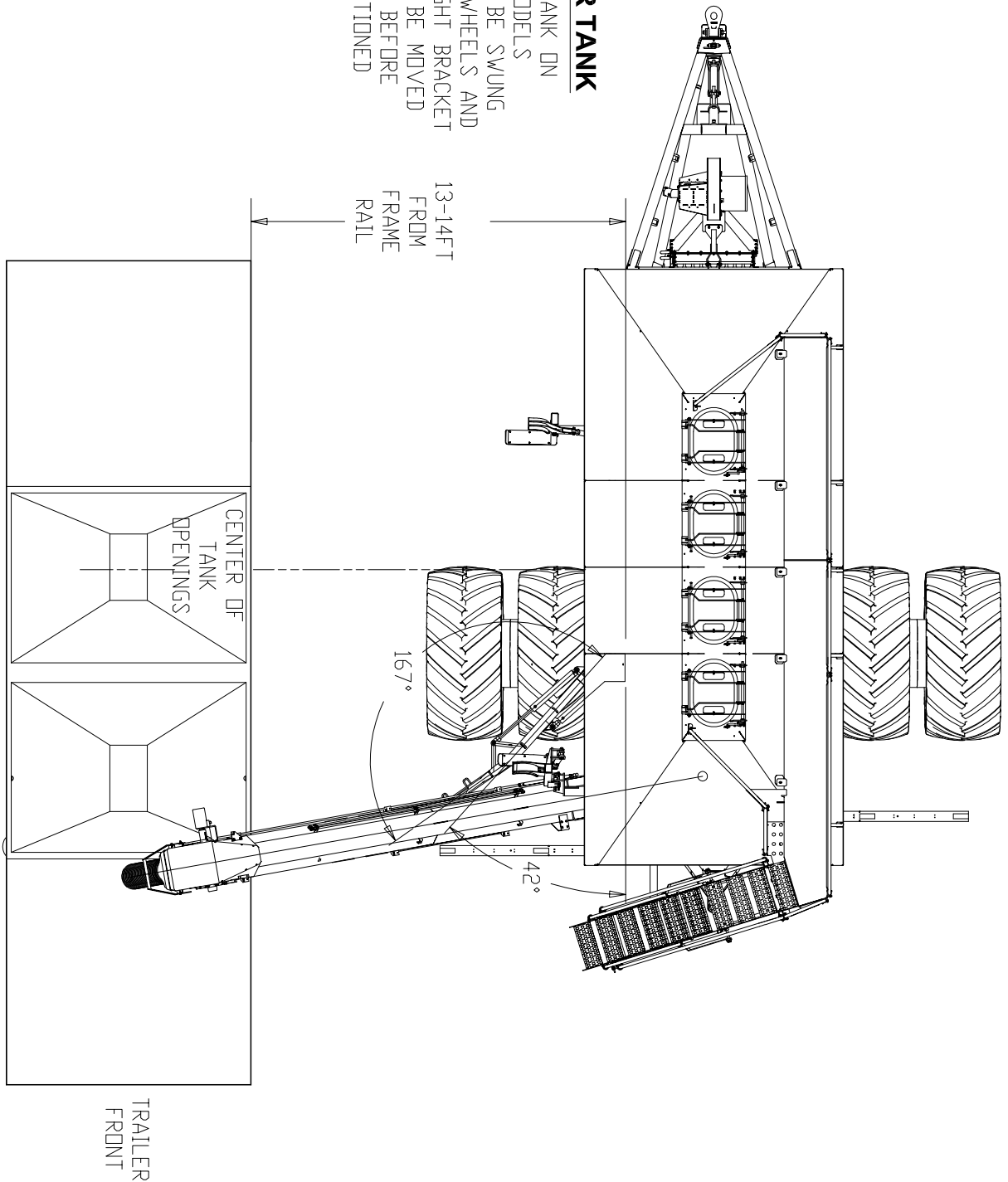

Operation

Semi Trailer Dump Positions - Continued

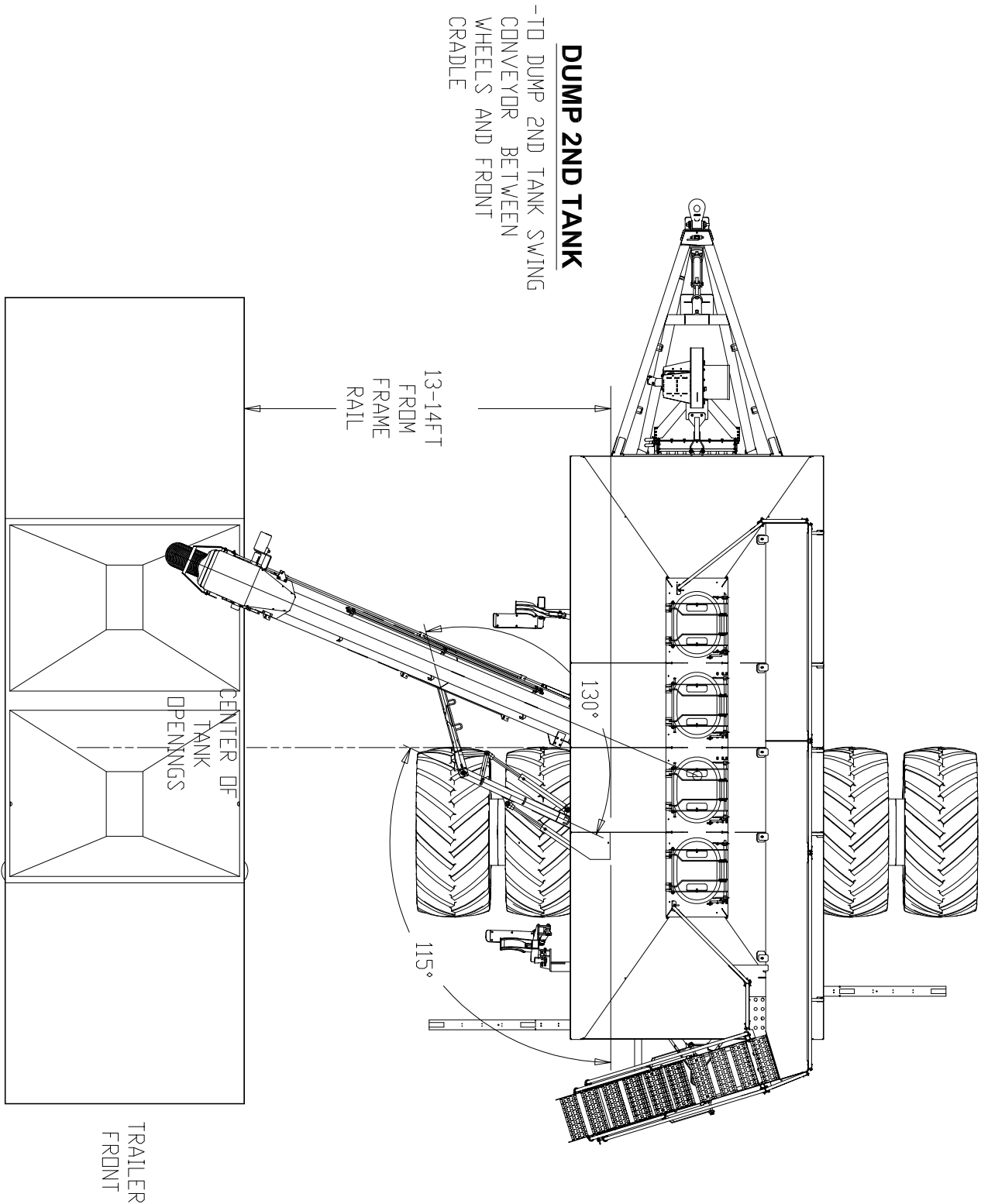

Semi Trailer Dump Positions - Continued

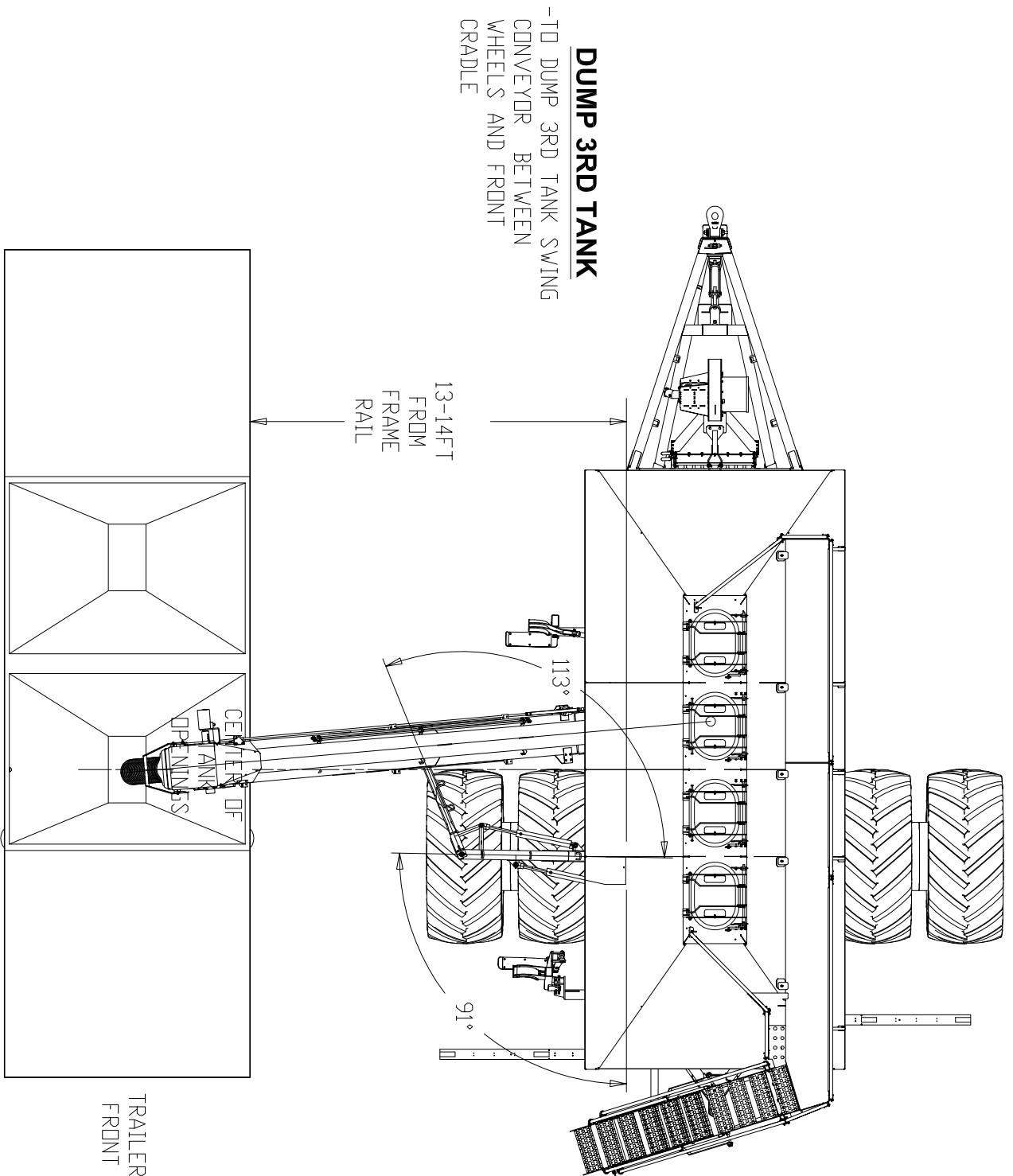

Operation

Semi Trailer Dump Positions - Continued

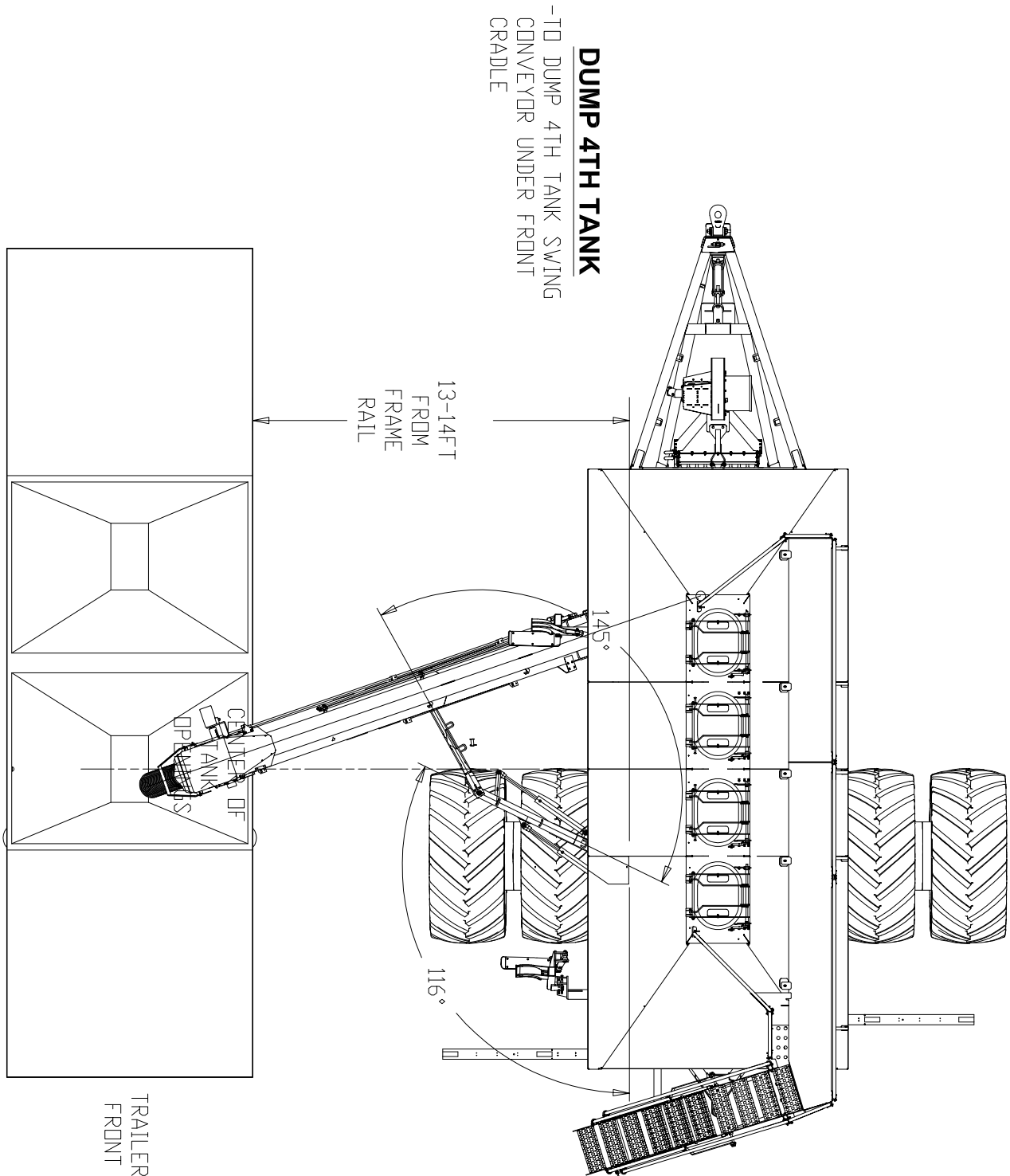

Filling Tank

The Morris 9 Series Air Cart is equipped with 2, 3 or 4 tanks. Typically the front tank is for seed and the middle and rear tank is for fertilizer. However, ALL tanks can be used for the same product.

The capacity of the air cart tanks are listed in the tank capacity chart.

- Open lid fully on tank being filled.
- Check and remove any debris inside tank.
- Open inspection door.
- Rotate seed plate fully open.
- Check for debris inside metering body.
- Ensure Tank Shut-Offs work freely.

Note: Tank Shut-Offs are only for use when inspecting/servicing meter body with product in tank.

- Check that the seed plate is set to correct position for the product being applied.
- Fully close and seal the inspection door.
- Ensure the auger screen is in place.
- Always use screen to filter debris when filling.
- Adjust bin level sensor to desired alarm point.

Note: Even small fertilizer lumps can cause problems with plugging. All possible precautions should be taken to prevent lumpy fertilizer from entering the tank.

Warning

Do not enter tank unless another person is present.



Important

Before putting product into the tanks check the following:

1. The seed plate is set to correct position for product being applied.
2. The inspection doors are fully closed and sealed.
3. The plastic bag covering the fan is removed.
4. Inspect all augers used in handling the products for seeding. Run augers to clean out any debris inside auger so it does not get transferred to air cart tanks.



Inspect Metering Body

Operation

Filling Tank - Continued

- Unlatch auger/conveyor lock.
- Swing out the auger/conveyor.
- Open lid on tank to be filled and place auger spout in tank.
- Position truck with the hopper and engage the hydraulic motor on the auger.
- Ensure selector valve is in correct position for auger operation and engage tractor hydraulics.

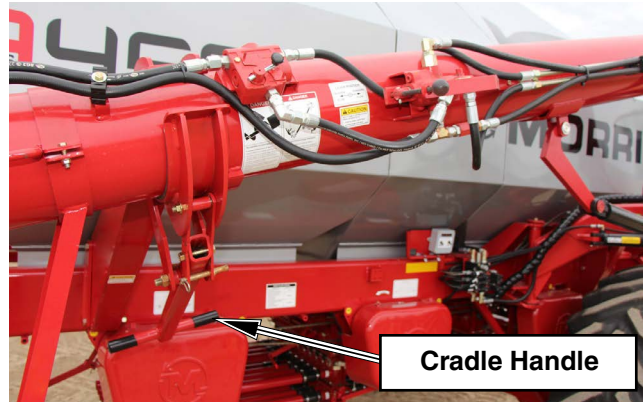

Cradle Lock - Auger shown

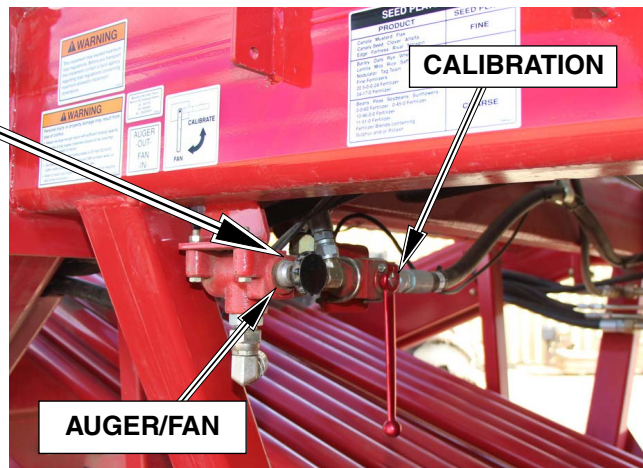

Selector Valves - Tow Behind shown



Conveyor Shown

Filling Tank - Continued

- Auger product into tank until desired level in tank is reached. (If equipped with the optional fill indicator fill until indicator light turns on. See “Full Bin Indicator”)
- Stop the flow of product into the auger/conveyor and allow auger/conveyor to empty.
- Auger operation can be controlled from either the top or bottom of the auger/conveyor.
- Clean lid seal and ensure lid seal is positioned correctly before closing tank lid.
- AUGER ONLY - Reverse auger flow to clean out the hopper.
- Place auger/conveyor in transport position.
- Secure auger/conveyor cradle locks.
- Remove the plastic bag covering fan.
- Check lid for air leaks with your hands once air cart fan is operational. See Maintenance Section 7.
- Check metering body for air leaks. See Maintenance Section 7.

Note: Before seeding it is recommended that after a rain or dew that fan be run for a few minutes to eliminate moisture in the system.

Important

Do not exceed 10 mph (16 kph)
in field operation.

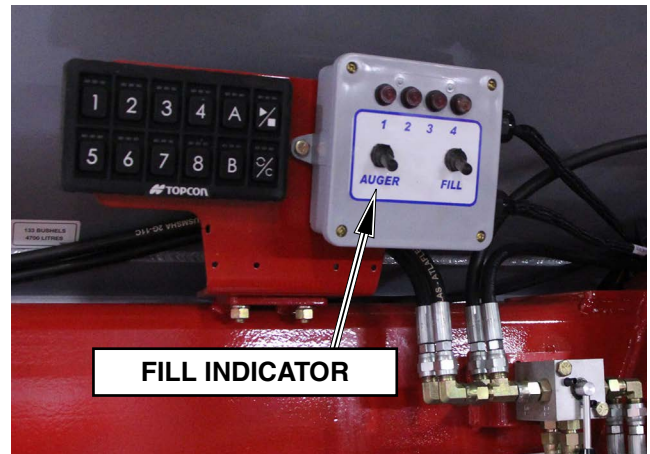

Fill Indicator



Auger Standard Hopper



Cradle Lock - Auger shown

Operation

Filling Tank - Continued

- Raise stairs into storage position.
- Engage stair lock to secure stairs in storage position.

Note: Stairway down indicator will flash when stairs are in lowered position.

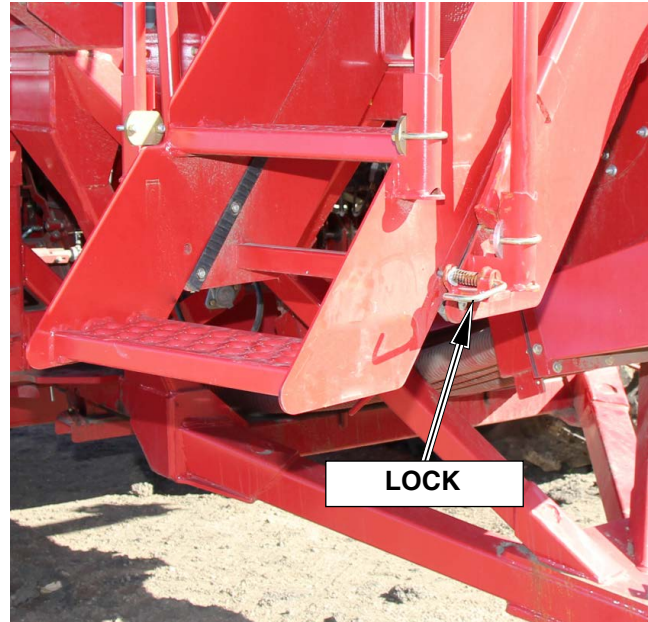

Stairs Locked in Storage Position

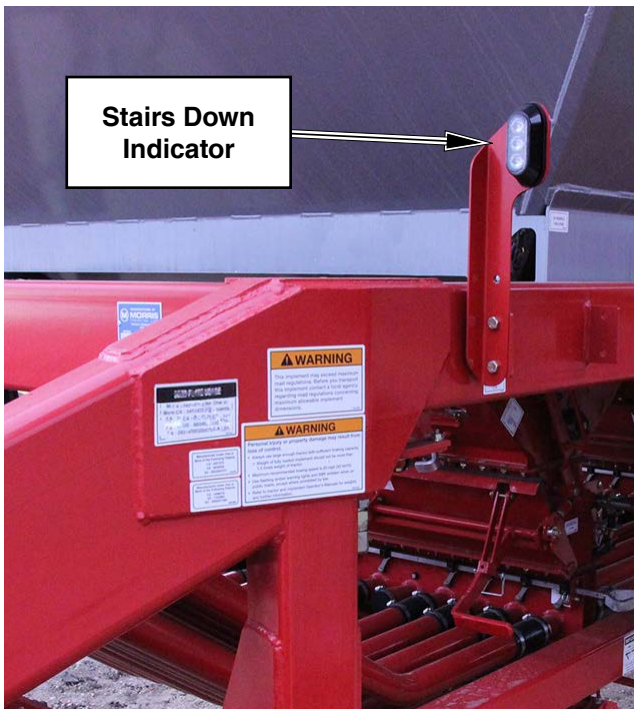

Important

Raise Stairs before moving Cart.
Stair damage will occur in lowered position.

A photograph showing the red stairs of the filling tank in their storage position, angled upwards. A white arrow points to the stairs. The background shows a large white cylindrical tank and a blue sky.

Unloading Tanks

Emptying tanks is quick and easy to do.

- Move flapper valves to “Clean-Out” position on the collector body. (Double Shoot Only)
- Open collector bottom.
- Install Clean-Out Chute to collector bottom, if so equipped.
- Position auger under the tank to be emptied.
- Start auger.
- Open Seed Plate Lever to the “Open” position, this will allow material to flow through the metering body into the auger.

Note: With Inspection Door closed the Seed Plate can be opened until it contacts door.

- Once all material stops flowing, move “Shut-off” levers in and out a few times to dislodge any product and ensure free movement.

continued on next page.

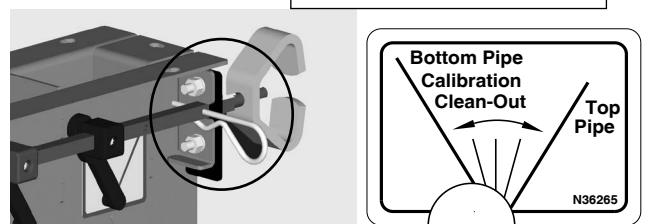
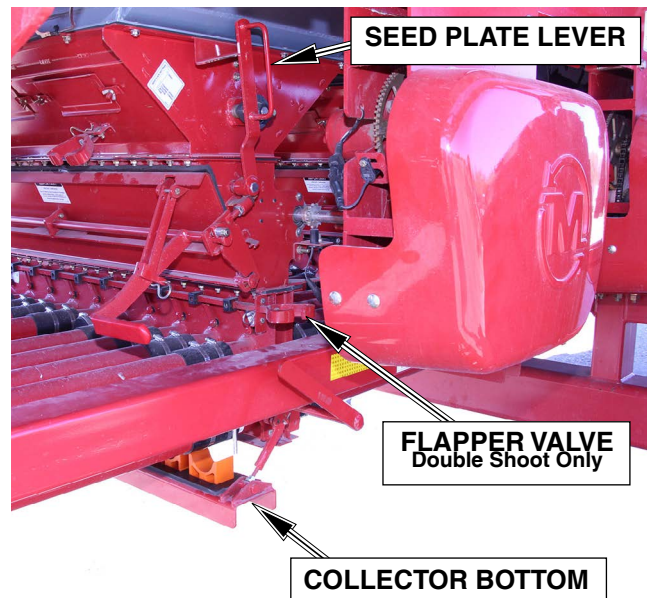

Double Shoot Only



Optional - Clean Out Chute



Operation

Unloading Tanks - Continued

- Open Inspection Door and rotate seed plate to fully open position.
- Open Pressure Chamber Covers and blow air around chamber to ensure it is free of debris.
- Brush out remaining material in the corners and on top of the back plate.
- Rotate meter shaft using Run-Rest box to empty meter wheel flutes.
- Reset flapper valves to correct position for product delivery. Ensure that the flapper settings are correct. This can be done by visually checking that the flappers are fully over and touching the side walls, sealing off the individual airstreams. The flappers can be adjusted by loosening the individual adjusting setscrews and applying pressure to the flapper forcing it against the side wall while tightening the setscrew.
- Set seed plate to correct position for product being metered.
- Install Pressure Chamber Covers ensuring that the seals are free from debris and leaks.
- Close inspection door and collector bottom ensuring that the seals are free from debris and leaks.

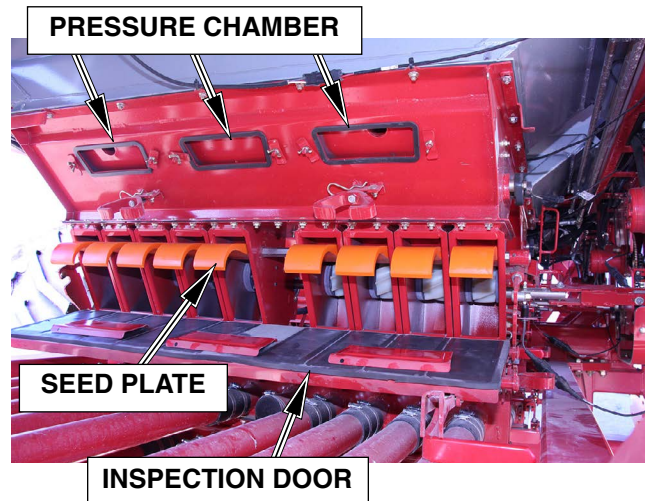

Danger

Keep all shields in place. Keep hands, feet and clothing away from auger intake, failure to do so will result in serious injury or death.

Rate Calibration

The practice of doing a rate calibration is strongly recommended, as it will confirm the **actual** amounts of product dispensed per motor revolution (**Weight/Rev**).

Weight/Rev (Calibration Factor) is used by the monitor to determine the shaft motor rpm required to deliver the correct application rate.

The following procedure should be followed for every change of product.

- Engage hydraulic lever to run air cart.
- **Turn off fan** by switching selector valve (located in the fan supply line) to calibration position.
- Open collector bottom.
- Set Flapper Valves to “**Calibration**” as per the decal located on the front of the Collector.

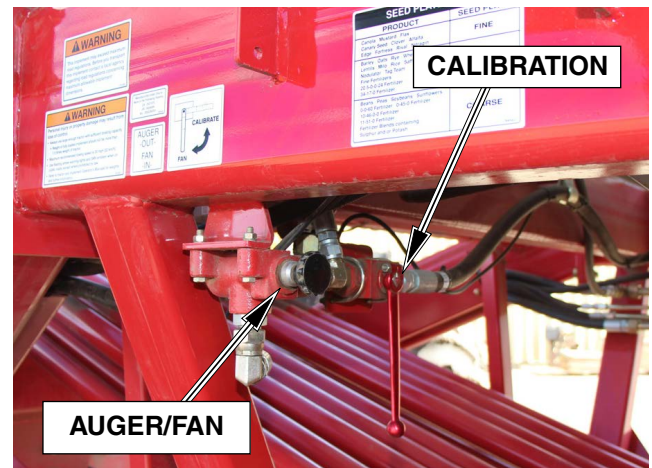

Selector Valves - Tow Behind shown

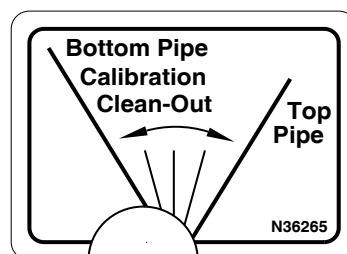
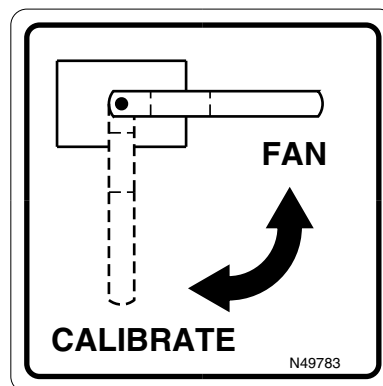

Decal on Collector

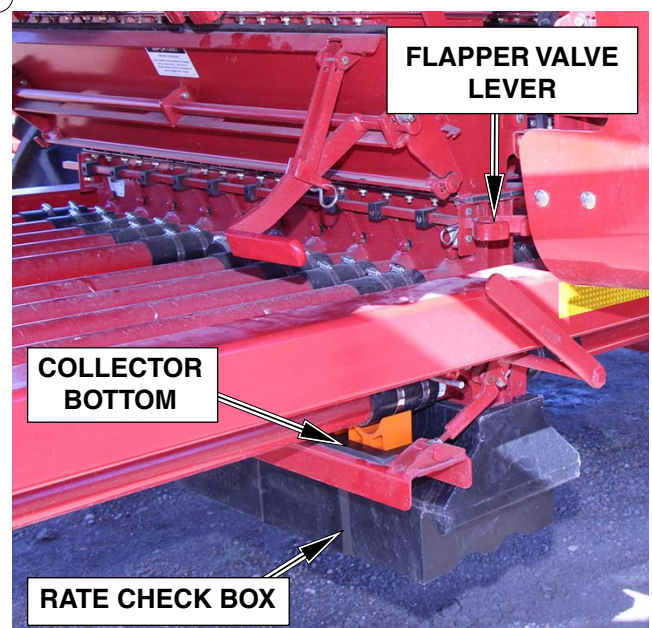

Double Shoot Shown

Operation

Rate Calibration - Continued

- Hook the Rate Calibration Insert on collector bottom and rotate up into position. Secure in place with slide lock.
- Slide the rate check box onto the collector body.
- **Prime metering wheels first** by using the Start/Stop button on the keypad to start and stop the meter drive. Allow the drive to run until material begins to fall through the collector body. Press the rest button for 5 seconds to zero monitor count before collecting sample.

Note: The Topcon monitor must be turned ON in order for the primer switch to work.

Note: *Ensure the fan is not running.*

- Empty material from rate check box and reinstall it on the same collector.

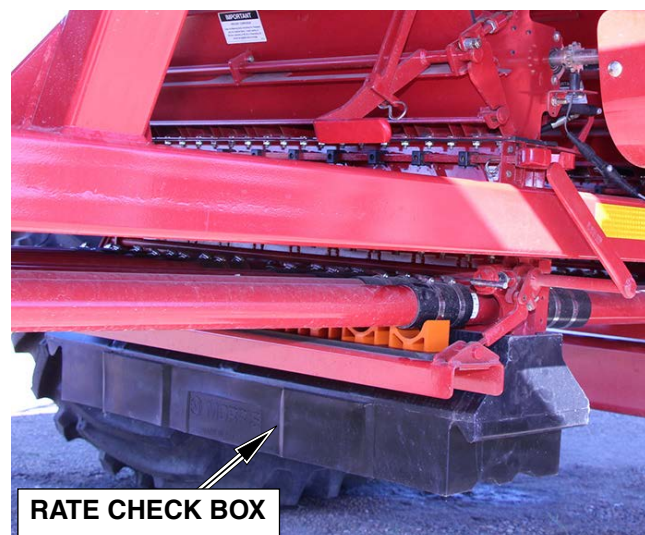
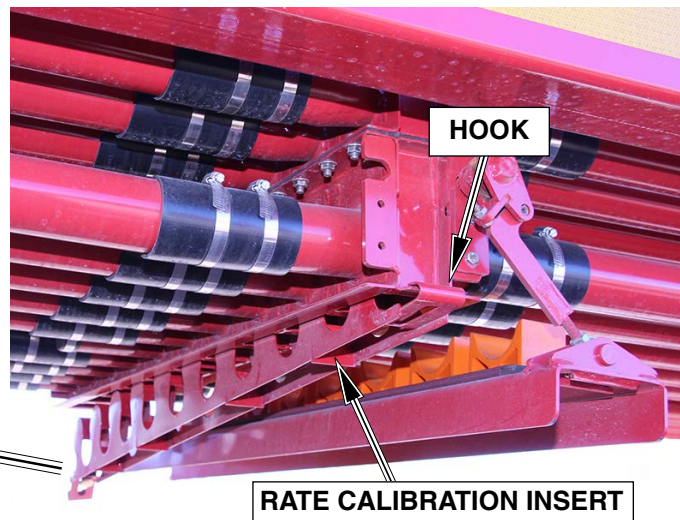
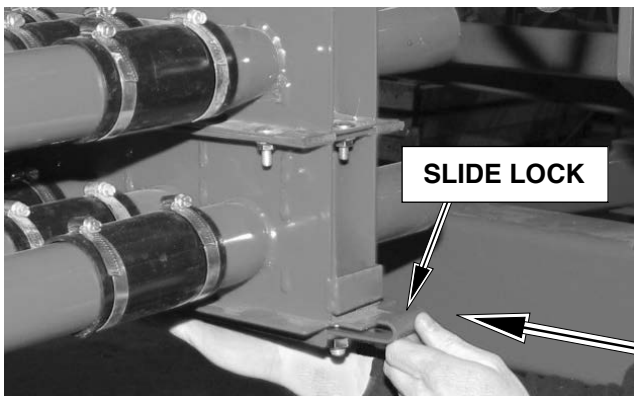
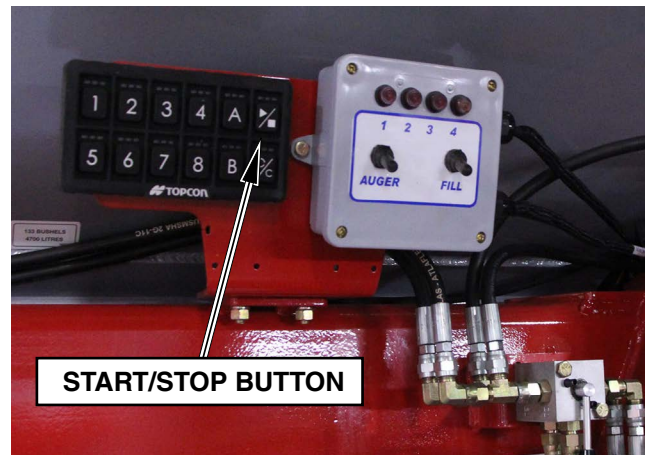

Rate Calibration - Continued

- Perform calibration as outlined in the Topcon manual.
- Remove the rate check box from the collector body.
Weigh the sample by using tarp straps to hook rate check box to spring scale.

Note: Remember to subtract the weight of the rate check box from the total sample weight.

- Enter “Weight” of product collected as outlined in the Topcon manual.

Note: The Calibration Factor (Weight/Rev) is automatically calculated for the value being entered.

- Remove rate calibration insert and close collector bottom ensuring that the seals are free from debris and leaks.
- Place rate check box into storage bracket.

Follow the above procedure to check the rate of the other tanks.



9450 Shown

Important

Proper measurement of sample weight is critical for application rate accuracy.

Prime metering wheels before taking actual sample.

Remember to subtract the weight of the rate check box from the total sample weight.

Important

Raise Stairs before moving Cart.
Stair damage will occur in lowered position.



Operation

Metering Rate Adjustment

The metering rate adjustment for all tanks is done in the same manner. A new rate is achieved by changing the APPLICATION RATE and or the Calibration Factor as outlined in the Topcon manual.

Note: It is recommended to set “Calibration Factor” by doing a “Rate Calibration”.

Seeding Fine Seeds (Canola, Mustard, etc.)

When seeding fine seeds such as canola or mustard, the slow speed transmission has to be engaged to ensure the low rates required for these products.

The slow speed transmission is incorporated in **All** the Posi-Drive Transmissions.

- To engage the slow speed, remove the large hairpin from the front shaft and install through the sleeve and shaft located at the rear of the transmission.

Note: Shaft will have to be rotated to align holes for pin insertion.

- To disengage the slow speed, reverse the above procedure.
- Rate checks can be performed the same way as for other seeds.
- Usually it is necessary to reduce the fan rpm when seeding fine seeds. See “Fan Speed” for specific fan speeds.

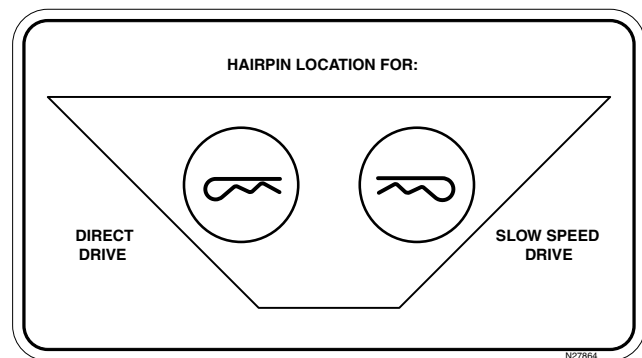

9450 Shown

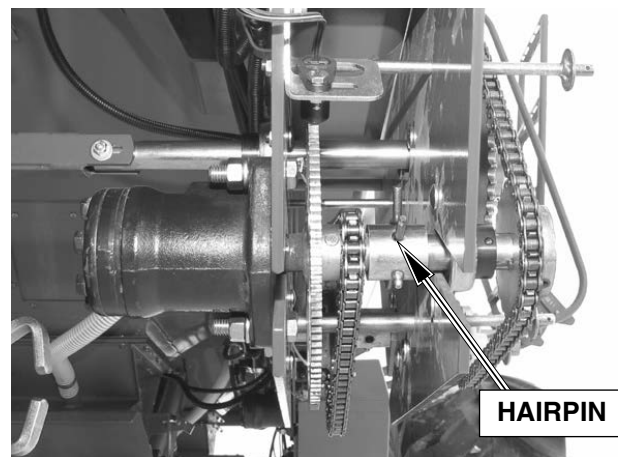

Cover removed for clarity

Applying Inoculant

When inoculant is applied at the time of seeding, once the air cart has been filled, the fill-lids should be left open and the fan run for 5-10 minutes at full rpm to dry the seed.

Calibration must be done after the seed is dried, otherwise the calibration will be incorrect.

Note: If the seed is not dried then the seed will have a tendency to bridge and not meter into the air stream.

Hydraulic Fan Drive

The piston type orbit motor on the fan requires tractor to have either a load sensing hydraulic system or a closed center hydraulic system with flow control.

The flow required is 21 U.S. gpm (80 liters) for the 16 cc motor at a pressure of 2,750 p.s.i. (18,960 kPa) However, smaller flows can be used depending on the product being metered.

Note: An additional 6 gpm (23 liters/min) is required for the VRT system.

For correct operation of the fan the hydraulic motor must be coupled to the priority valve (if tractor is so equipped) in the hydraulic valve bank.

Check with the tractor manual or manufacturer to determine if or which spool is a “priority valve”.

Speed fluctuations will result if the fan is not connected to the priority valve if hydraulic system is equipped with a priority valve.

Ensure couplers are free of dirt and are clean when connecting the fan hydraulics to the tractor.

Fan speed is adjusted by increasing the amount of oil being delivered to the motor by adjusting the respective flow control valve until the desired rpm is displayed on the monitor.

Note: There is a one-way check valve installed in the hydraulic circuit. If the fan does not rotate, then move hydraulic lever in the opposite direction; this will engage the fan. This valve prevents damage to the hydraulic systems when the fan is shut OFF, by allowing the fan to freewheel.

A piston motor creates leakage past the internal components for lubrication. This oil needs to go back to the oil reservoir at the lowest pressure possible. The motor has a 3/8” diameter case drain line. This line must be connected directly into the tractor hydraulic reservoir to ensure that there is zero back pressure in the drain line; otherwise damage will result to the motor.



Hydraulic Drive

IMPORTANT

Run hydraulic fan drive at lowest rpm possible (1,000-2,000) for 5-10 minutes before operating at set rpm. This is required to warm up the hydraulic fluid. Cold hydraulic fluid will cause pressure spikes in the system that will damage the case drain seal in the orbit motor.

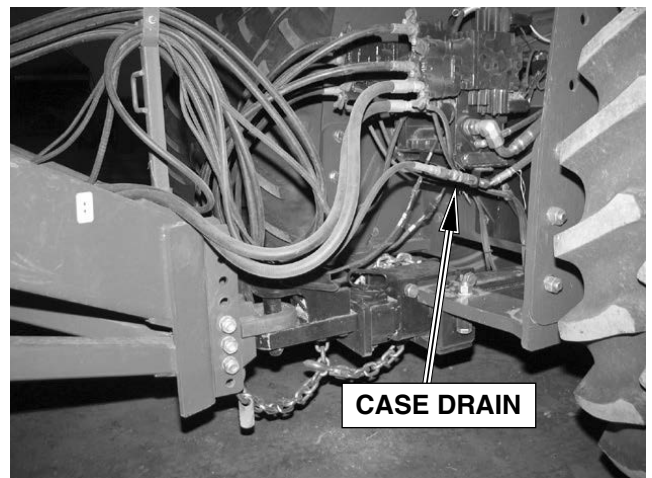

Hydraulic Coupling on Tractor

Operation

Fan Speed Recommendations

Adequate air volume is necessary at all times to carry the product in the air stream. Air volume can be controlled by adjusting hydraulic oil flow on hydraulic fan drives.

Air volume; hence fan speed requirements will vary with:

1. Ground speed
2. Metering rate
3. Number of primary runs
4. Secondary hose size
5. Width of machine
6. Density and size of material

Excessive fan speed can cause seed damage, seed bouncing and premature wear of the system.

Generally fan speed is adequate if product flows through the hoses without surging and the hoses empty quickly and evenly when the system shuts down.

Morris recommends the following operating guidelines for fan speed:

1. Do not operate the fan below 3000 rpm with 1 inch diameter secondary hose.
2. Do not operate the fan below 3500 rpm with 1 1/8 inch diameter secondary hose. Add an additional 500 rpm to speeds shown on the charts.
3. If equipped with a dual fans, keep the speed difference between the two fans within 1000 rpm.
4. Units equipped with VR drives the recommended minimum fan speed is 3500 rpm to ensure sufficient hydraulic flow to the VRT hydraulic valve block.

The charts on the next page list *suggested fan speeds* for various application rates.

Note: The charts should be used only as a guide. If plugging or surging occurs increase the fan speed to eliminate the problem.

Note: It is recommended that after a rain or dew the fan be run two to three minutes to expel any moisture in the system.

Important

Keep fan impeller blades clean at all times.

Note: Once fan speed is properly set, be sure to adjust the monitor fan alarm setting accordingly. Refer to X30 manual N55777 and X30 ICT manual N55799 for more details. For X35 monitor manual N65100 and X35 ICT manual N65101.

Dual Fans

Use application rate of individual air stream to determine fan speed for that air stream.



Fan Speed Recommendations - Continued

Charts are based on a 41 foot machine traveling at 5 mph (8 kph).

17 inch Diameter Impeller Suggested Fan RPM @ 5 mph (8 kph) on a 41 ft unit 1 inch (25 mm) Secondary Hose		
For 1 1/8 inch (28.6 mm) Secondary Hose add an additional 500 rpm to values below.		
Combined Application Rate	Fan Speed Setting	
	Single Shoot	Double Shoot
3 - 50 lbs/acre 3 - 56 kg/ha	3000 - 3250 RPM	3000 - 3150 RPM
50 - 100 lbs/acre 56 - 112 kg/ha	3250 - 3500 RPM	3150 - 3400 RPM
100 - 150 lbs/acre 112 - 168 kg/ha	3500 - 3750 RPM	3400 - 3650 RPM
150 - 200 lbs/acre 168 - 224 kg/ha	3750 - 4000 RPM	3650 - 3900 RPM
200 - 250 lbs/acre 224 - 280 kg/ha	4000 - 4250 RPM	3900 - 4150 RPM
250 - 300 lbs/acre 280 - 336 kg/ha	4250 - 4500 RPM	4150 - 4400 RPM
300 - 350 lbs/acre 336 - 392 kg/ha	4500 - 4750 RPM	4400 - 4650 RPM
> 350 lbs/acre > 392 kg/ha	4750 - 5000 RPM	4650 - 4900 RPM
Note: Fan Speeds given are when applying product. It is normal for fan speed to drop when not applying product.		

Note: In a variable rate application set fan speed to match maximum product rate being applied.

Dual Fans

Use application rate of individual air stream to determine fan speed for that air stream.

Important:

Morris recommends not to operate the fan below 3000 rpm and if equipped with a dual fan setup to keep the speed difference within 1000 rpm. Units equipped with VR drives the recommended minimum fan speed is 3500 rpm to ensure sufficient hydraulic flow to the VRT hydraulic valve block.

Operation

Fan Speed Recommendations - Continued

Charts are based on a 71 foot machine traveling at 4.5 mph (7.2 kph).

17 inch Diameter Impeller Suggested Fan RPM 4.5 mph (7.2 kph) on a 71 ft unit for 1 inch (25 mm) Secondary Hose		
For 1 1/8 inch (28.6 mm) Secondary Hose add an additional 500 rpm to values below.		
Combined Application Rate	Fan Speed Setting	
	Single Shoot	Double Shoot
3 - 50 lbs/acre 3 - 56 kg/ha	3250 - 3500 RPM	3000 - 3250 RPM
50 - 100 lbs/acre 56 - 112 kg/ha	3500 - 3750 RPM	3250 - 3500 RPM
100 - 150 lbs/acre 112 - 168 kg/ha	3750 - 4000 RPM	3500 - 3750 RPM
150 - 200 lbs/acre 168 - 224 kg/ha	4000 - 4250 RPM	3750 - 4000 RPM
200 - 250 lbs/acre 224 - 280 kg/ha	4250 - 4500 RPM	4000 - 4250 RPM
250 - 300 lbs/acre 280 - 336 kg/ha	4500 - 4750 RPM	4250 - 4500 RPM
300 - 350 lbs/acre 336 - 392 kg/ha	4750 - 5000 RPM	4500 - 4750 RPM
> 350 lbs/acre > 392 kg/ha	-	4750 - 5000 RPM
Note: Fan Speeds given are when applying product. It is normal for fan speed to drop when not applying product.		

Note: In a variable rate application set fan speed to match maximum product rate being applied.

Dual Fans

Use application rate of individual air stream to determine fan speed for that air stream.

Important:

Morris recommends not to operate the fan below 3000 rpm and if equipped with a dual fan setup to keep the speed difference within 1000 rpm. Units equipped with VR drives the recommended minimum fan speed is 3500 rpm to ensure sufficient hydraulic flow to the VRT hydraulic valve block.

Plenum Settings

Plenum Damper Settings

18 Outlet Plenum

Adequate air volume is necessary at all times to carry the product in the air stream. Air volume can be controlled by adjusting the plenum damper settings.

The table below lists initial plenum damper settings for certain products.

Note: The settings in the table should be used only as a guide.

- If **fertilizer** plugging or surging occurs **decrease** the seed damper setting to eliminate the problem.
- If **seed** plugging or surging occurs **increase** the seed damper setting to eliminate the problem.

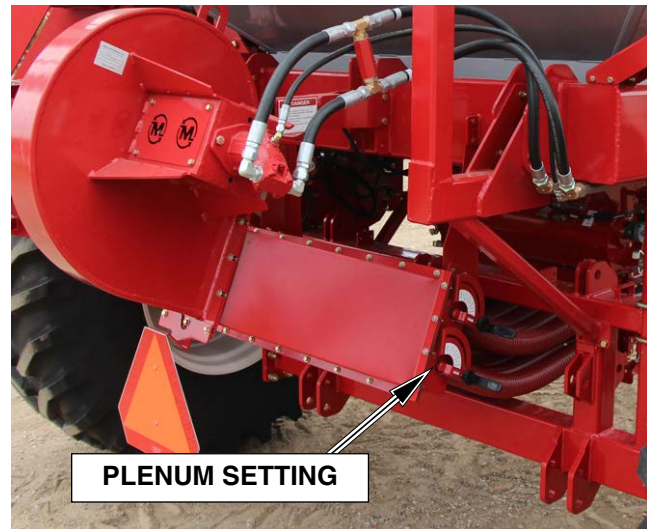

Set Plenum Damper so that setting is in the middle of slot.
This Damper is set at the 2 position.

Suggested Plenum Settings				
Product	Seed		Fertilizer	
	Rate lb/acre	Damper Setting	Rate lb/acre	Damper Setting
Fine Seeds	All Rates	1	All Rates	Open
Coarse Grains	90 lb (100 kg/ha)	Open	50 lb (56 kg/ha)	2
	90 lb (100 kg/ha)	4	100 lb (112 kg/ha)	Open
	90 lb (100 kg/ha)	3	150 + lb (168 kg/ha)	Open
Large Seeds	180 lb (200 kg/ha)	Open	40 lb (45 kg/ha)	2
Single Shoot	Lower Pipes	- Top Damper Closed - Bottom Damper Open		
	Upper Pipes	- Top Damper Open - Bottom Damper Closed		

Note: See “Fan Speeds” for Fan RPM.

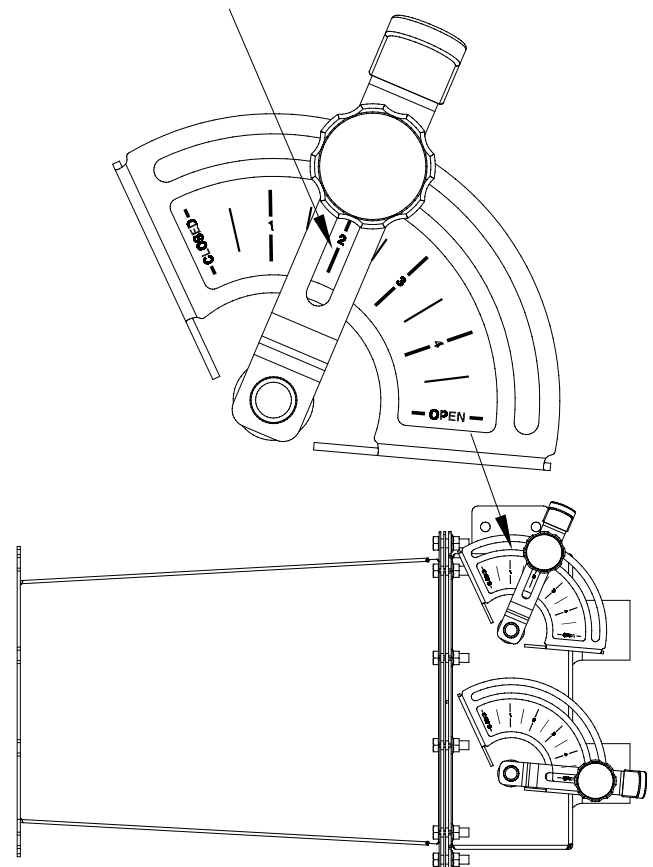

Operation

Double Shoot Settings

Collector Valve Settings

Located in each upper collector body are flapper valves for machines equipped with Double Shoot. The flapper valve must be properly set in order for product to flow correctly.

See illustrations on following pages for specific settings for various combinations for Double and Single Shoot set ups.

Flapper valves must be cycled daily to free valves of any fertilizer and grain dust accumulations.

Whenever valves are cycled or reset to a new position the position should be visually inspected as follows:

- Set flapper valves to correct position for product delivery.
- Remove the inspection door and visually check that the flappers are fully over and touching the side walls, sealing off the individual air streams.
- The flappers can be adjusted by loosening the individual adjusting setscrews and applying pressure to the flapper forcing it against the side wall while tightening the setscrew.

Note: The bottom air stream should be used to carry the higher rate of product.

Flapper Valve Run Test

Use the following procedure to check that the flapper valves do not move when air pressure is applied to under side of flappers.

- Check flapper valves in both directions with air running.
 - If valve is set to direct product into the bottom pipe, have the plenum damper open for the top pipes and closed to the bottom pipes.
 - If valve is set to direct product into the top pipe, have the plenum damper open for the bottom pipes and closed to the top pipes.
- **Always wear** safety goggles, breathing apparatus and gloves when working with granular chemical or treated seed per the manufacture's instructions.
- With fan running check flapper valve position.
- The flappers can be adjusted by loosening the individual adjusting setscrews and applying pressure to the flapper forcing it against the side wall while tightening the setscrew.

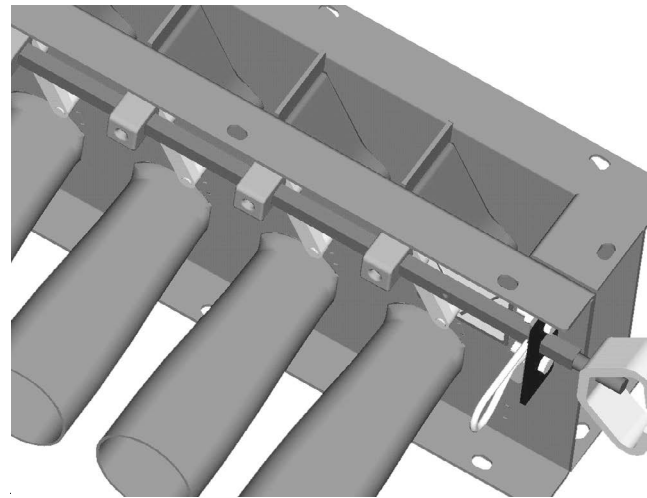

Flapper in "Bottom Pipe" Setting

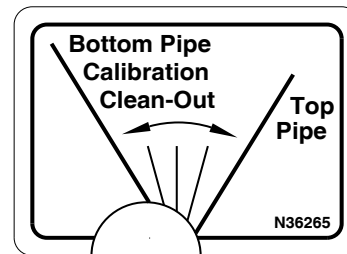

Decal on Collector

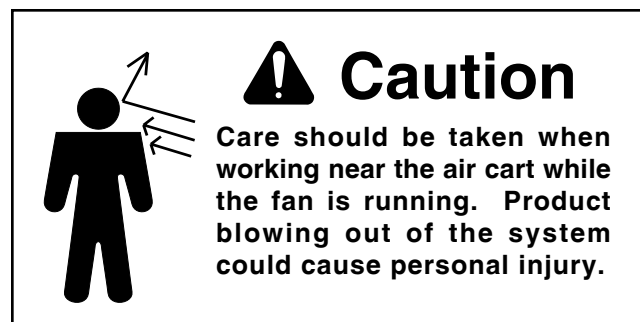
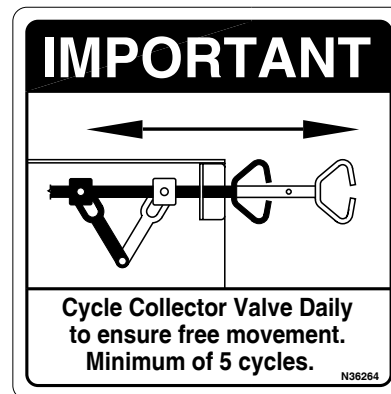

Operating Guidelines

There are a number of areas that can cause problems when seeding. Listed below are specific points that should be addressed at all times. Following these guidelines will ensure better crop emergence and consequently the potential for better yields.

An improperly leveled seeding tool cause uneven depth, which could result in poor emergence.

It is important that the seeding tool is leveled both side to side and front to back.

Check Tire Pressures

- Ensure all tires are inflated to their specified pressure. Incorrect tire pressure can cause depth variations.

Level Seeding Tool

Side to Side

- Check the depth of each shovel on the back row.
- Adjust side to side level as necessary. See seeding tool manual for more details.

Front to Rear

- Poor front to rear leveling causes ridging as shown.
- Check the depth of two adjacent shanks, normally one on the front row and one on the rear row.
- Adjust level as necessary. See seeding tool manual for more details.

Worn Seeding Tool Parts

- Shanks that are bent cause uneven depth and they should be repaired or replaced.
- Trip mechanisms that are worn can also cause poor depth control and any worn parts should be repaired or replaced.

Packing

- Packing behind the seeding unit is strongly recommended. This improves germination and helps reduce moisture loss and erosion.
- In wet conditions the head land should be done last to prevent over packing.

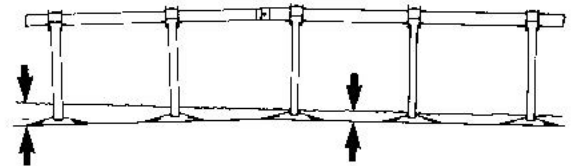

Side to Side Level

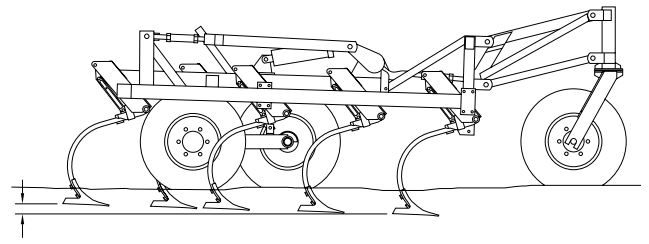

Front to Back Level

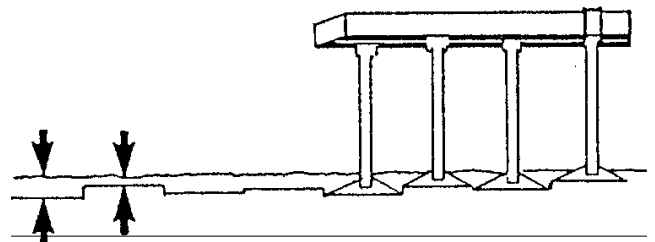

Ridging Front to Back

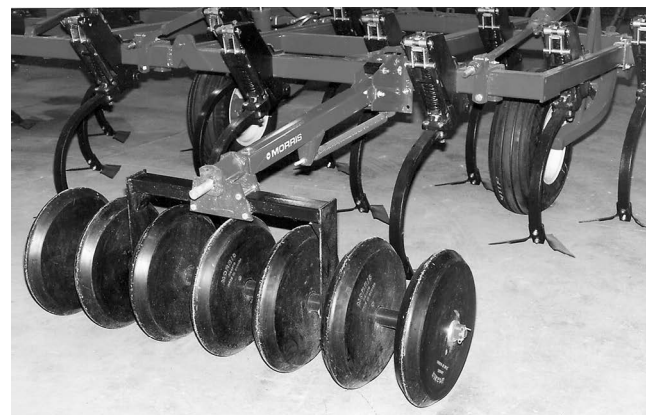

Mounted Packers

Operation

Operating Guidelines - Continued

Turning

- Avoid sharp turns. Backing up of the outer wings with the seeding tool in the ground has a tendency to plug the seed boot with soil.
- Raise seed boots fully before making sharp turns or backing machine.

Seed Rate Settings

- Remove any caked-on material from seed plate and metering wheels.
- Ensure correct seed plate is installed and metershaft turns freely.
- Check product rates carefully by performing a calibration check.

Fertilizer Application

- Avoid using fertilizers that absorb moisture readily, especially during periods of high humidity.
- Also avoid fertilizers that contain a high percentage of fine dust, as these materials can plug metering wheels and coat the inside of seed distribution system.

Fan Setting

- Run fan at recommended speed. If plugging or surging occurs increase the fan speed to eliminate the problem. If plugging or surging continues reduce ground speed to eliminate the problem.
- Allow tractor hydraulic oil to warm-up thoroughly prior to seeding. Cold oil will cause slower fan speeds (Hydraulic driven fan).

Product Application

- Control product application with the clutch switch in tractor.
- Have machine moving forward before lowering seed boots to avoid plugging.
- To prevent skipping, allow a minimum of 15 feet (5 m) of forward travel to ensure air system has delivered product to seed boots.

Forward travel should be equal to half the width of the seeding tool. [i.e. for a 40 ft (14 m) wide seeding tool the forward travel should be a minimum of 20 feet (7 m).]

Note: It is strongly recommended to consult local agricultural extension offices for allowable product rates, which are dependent on soil moisture and type.

Important

Raise Stairs before moving Cart.
Stair damage will occur in lowered position.



Note: Do not attempt to meter product when fan is not running. Damage to the metering wheels may occur.

Operating Guidelines - Continued

Adjustments and Operational Checks

- When changing fields and periodically throughout the day, the seeding tool should be checked for level and depth and the seed boots for blockage.

Checking Seed Flow

The following procedure should be implemented throughout the day typically at each fill of the air cart:

- Raise the seeding tool out of the ground.
- With the fan running and monitor on, engage meter drives with the Start/Stop button on the keypad, rotating meter drives 4 to 5 times.
- Seed and/or fertilizer should appear at each outlet on the ground.
- If no seed or fertilizer appears on the ground at any of the openers check for hose blockage in both the 15/16" (24 mm) diameter secondary and the 2 1/2" (64 mm) diameter primary hose, as well as in the flat fan divider.
- See Trouble Shooting Section for possible causes of the blockage.

Moisture Alert

- Whenever air cart has been standing for an hour or more during period of high humidity or damp, rainy days, or after sitting overnight, run fan at recommended rpm, with machine stationary for 5 minutes.

Air Leaks

It is imperative that no excessive air leaks occur in the air cart tank. Air leaks can lead to product bridging in the tank thereby causing misses in the field.

Check the following areas for air leaks:

- Tank lid
- Tank clean-out door
- Collector assembly seals
- Metering body assembly seals

Tank Low in Product

- Refill tank before metering wheels are exposed.
- The metering wheels must be completely covered to avoid unseeded strips.

Important

Check Metering Wheel flutes in the event the primary lines plug.

Flutes may shear if the collector becomes plugged.

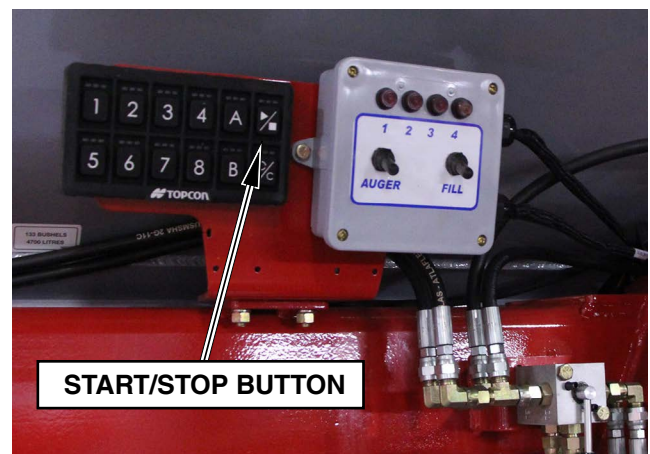

Note : Check Seed Flow as described above, after running fan for 5 minutes.

Operation

Operating Guidelines - Continued

Monitor

- Familiarize yourself with all monitor functions as outlined in the Topcon manual.
- Ensure all monitor “*settings*” are correctly set for the air cart/seeding tool combination.
- Recognize and correct alarm conditions as indicated on the monitor.
- Check all wire harness connections for corrosion and use a dielectric spray to clean. Inspect all sensors for proper gap.

General Field Operation

- Follow guidelines outlined in “*Operating Guidelines*”.
- Switch monitor on as outlined in the Topcon manual.
- Start fan.

Note: Load sensing hydraulic systems require “*warming up*” before they function smoothly. See “*Hydraulic Fan Drive*” for more details.

- Move forward with seeding tool.
- Engage metering systems as outlined in the Topcon manual.
- Lower seeding tool into ground.
- Product rates can be varied as desired by using the INCREASE and DECREASE buttons for the appropriate product as outlined in the Topcon manual.
- Turning at headland: Switch metering systems off with the Master Switch, immediately raise seeding tool, fully rephasing hydraulics (see seeding tool manual).
- Once turn is complete engage metering systems with the Master Switch and lower seeding tool into ground.

Note: Do not attempt to meter product when fan is not running. Damage to the metering wheels may occur.

Note: Engage console master switch early enough to avoid misses. Forward travel should be equal to half the width of the seeding tool. [i.e. for a 40 ft (14 m) wide seeding tool the forward travel should be a minimum of 20 feet (7 m).]

Section 6: Maintenance

Section Contents

General	6-2
Safety	6-2
Tighten Bolts.....	6-3
Tires.....	6-4
Daily Maintenance.....	6-5
Lubrication.....	6-6
Air Delivery System	6-7
General	6-7
Tank Lid Adjustment.....	6-8
Inspection Door Adjustment.....	6-9
Clean Out Door Adjustment.....	6-10
Air Leak Check.....	6-11
Fan.....	6-12
Rotor Clearance.....	6-13
Hoses.....	6-13
Equalizers	6-14
Hydraulic Orbit Motor.....	6-15
Hydraulics.....	6-16
Wheel Bearings	6-17
Quad Steer	6-18
Dual Wheels	6-18
Dual Wheel 9800 and 91000 - 38 Rims.....	6-19
Rim Identification	6-19
Titan Rim.....	6-20
Moveero (GKN) Rim.....	6-22
Seed Plate Adjustment.....	6-26
Tie Rod - Tow Between.....	6-27
Conveyor	6-28
Brakes	6-40
Fill Reservoir.....	6-40
Bleeding the Brakes.....	6-40
Brake Pads	6-41
Caliper Pistons and Seal Replacement	6-41

Maintenance

CAUTION



BE ALERT

SAFETY FIRST

REFER TO SECTION 1 AND REVIEW ALL
SAFETY RECOMMENDATIONS.

General

This section deals with two goals, maximum life and dependable operation. Adopt a regular maintenance and lubrication program. Care and sufficient lubrication is the best insurance against delays.

Safety

- Always shut off the tractor and remove key before dismounting.
- Guard against hydraulic high pressure leaks with hand and face protection.
- Never work under the implement unless it is in the down position or transport lock pins are in place and secured with hair pins. Do not depend on the hydraulic system to support the frame.
- Always wear safety goggles, breathing apparatus and gloves when working on seeder filled with chemical. Follow manufactures recommended safety procedures when working with chemicals or treated seeds.
- Do not feed left over treated seed to livestock, treated seed is poisonous and may cause harm to persons or livestock.

 **Warning**

Securely support any machine elements that must be raised for service work.

 **Caution**

Keep service area clean and dry. Wet or oily floors are slippery.





Tighten Bolts

- Before operating the air cart.
- After the first two hours of operation.
- Check tightness periodically thereafter.
- Use Bolt Torque Chart for correct values on various bolts.
- Note dashes on hex heads to determine correct grade.

Note: DO NOT use the values in the Bolt Torque Chart if a different torque value or tightening procedure is given for a specific application.

- Fasteners should be replaced with the same or higher grade. If higher grade is used, only tighten to the strength of the original.

Bolt Torque Chart				
Grade 5 Bolt Marking 		Bolt Size	Grade 8 Bolt Marking 	
Nm	lb-ft		lb-ft	Nm
11	8	1/4	12	16
23	17	5/16	24	33
41	30	3/8	45	61
68	50	7/16	70	95
102	75	1/2	105	142
149	110	9/16	155	210
203	150	5/8	210	285
366	270	3/4	375	508
536	395	7/8	610	827
800	590	1	910	1234
1150	850	1-1/8	1350	1850
1650	1200	1-1/4	1950	2600
2150	1550	1-3/8	2550	3400
2850	2100	1-1/2	3350	4550

Important

Retorque wheel nuts after first fifteen minutes of operation and every fifteen minutes for the next 2 hours. Check periodically afterwards.

Wheel Bolt Torque	
SIZE	Torque
9/16	110 lb-ft (149 Nm)
5/8	150 lb-ft (203 Nm)
3/4 Grade 8	450 lb-ft (610 Nm)
7/8 Grade 8	525 lb-ft (712 Nm)
22 mm	500 lb-ft (678 Nm)
** 24 mm	Moveero Rim - 590 lb-ft (800 Nm)
** 24 mm	Titan Rim - 800 lb-ft (1085 Nm)

**** Refer to “Dual Wheel 9800 and 91000 - 38 Rims” for details.**

Maintenance

Tires

- Inspect tires and wheels daily for tread wear, side wall abrasions, damaged rims or missing lug bolts and nuts. Replace if necessary.
- Tighten wheel bolts - refer to Wheel Bolt Torque Chart.
- Check tire pressure daily, when tires are cold.
- Correct tire pressure is important.
- Do not inflate tire above the recommended pressure.



Caution

Tire replacement should be done by trained personnel using the proper equipment.

Tire Specifications										
Tire	Style	Rating	Pressure							
			BT 9365 9450	BH 9365 9450	BH 9535	BT 9445 9550 9650	BH 9445 9550 9650	BT 9800	BH 9800 91000	
28LR26 750/65R26 Quad Steer	Lug	169 A8	-	18 psi 124 kPa <small>OPT Front Axle</small>	18 psi 124 kPa <small>STD Front Axle</small>	-	-	18 psi 124 kPa <small>STD Front Axle</small>	-	-
500/70 R24 Front Castor	Lug	LI 157	-	25 psi 172 kPa <small>STD Front Axle</small>	-	-	-	-	-	-
520/85R38 Dual Wheels	Lug	155 A8	-	20 psi 138 kPa <small>OPT Rear Axle</small>	-	-	-	-	-	-
710/70R38	Lug	166A8	-	-	-	-	-	36 psi 248 kPa <small>OPT Rear Axle</small>	-	-
800/65R32	Lug	172 A8	20 psi 138 kPa <small>STD Rear Axle</small>	20 psi 138 kPa <small>STD Rear Axle</small>	-	-	-	-	-	20 psi 138 kPa <small>STD Front Axle</small>
800/65R32 Dual Wheels	Lug	172 A8	20 psi 138 kPa <small>OPT Rear Axle</small>	20 psi 138 kPa <small>OPT Rear Axle</small>	20 psi 138 kPa <small>OPT Rear Axle</small>	20 psi 138 kPa <small>STD Rear Axle</small>	20 psi 138 kPa <small>OPT Rear Axle</small>	-	-	-
800/70R38	Lug	173 A8	-	-	-	-	-	-	-	20 psi 138 kPa <small>OPT Front Axle</small>
900/60R32	Lug	176 A8	17 psi 117 kPa <small>OPT Rear Axle</small>	17 psi 117 kPa <small>OPT Rear Axle</small>	26 psi 179 kPa <small>STD Rear Axle</small>	-	-	26 psi 179 kPa <small>STD Rear Axle</small>	-	-

*BH - Tow-Behind only

*BT - Tow-Between only

STD - Standard

9800 and 91000 Titan Tires		
Tire	Pressure	
	Inner Dual	Outer Dual
800/70R38 Dual Wheels	22 psi 152 kPa	20 psi 138 kPa
850/80R38 Dual Wheels	17 psi 118 kPa	15 psi 104 kPa

9800 and 91000 Moveero and Trelleborg Tires		
Tire	Pressure	
	Inner Dual	Outer Dual
IF800/70R38 Front Single Wheel	15 psi 104 kPa	NA
IF800/70R38 Rear Dual Wheels	15 psi 104 kPa	15 psi 104 kPa

Daily Maintenance

- Check for and remove any water in primary collectors and pressure lines after rainy weather. Remove all inspection doors and collector bottoms to drain water from the tanks and collectors.
- Reinstall collector bottoms and inspection doors.
- Ensure fan screen is clear of debris.

Note: Start fan and run for 3 - 5 minutes prior to loading machine to get rid of accumulated moisture.

- Check lid seals for damage, and that they are sitting properly on steel ring.
- Check the pressure chamber and inspection door chamber for dust build up. Clean out and remove any excess buildup of dust between the seed plate and the inspection door.
- Check tank pressure hoses for leaks, cracks or plugging.
- Check the following areas for air leaks:
 - Tank inspection door
 - Metering body assembly seals
 - Collector assembly seals
 - Tank lid

Refer to “Air Leak Check” under Air System Maintenance.

- Check monitor wiring that all sensor wires are properly routed and retained.
- Check for plugged hoses.
- Cycle Collector Valve five times to ensure parts are free to move.
- Ensure drive chains are cleared of debris.
- Check torque on wheel bolts.

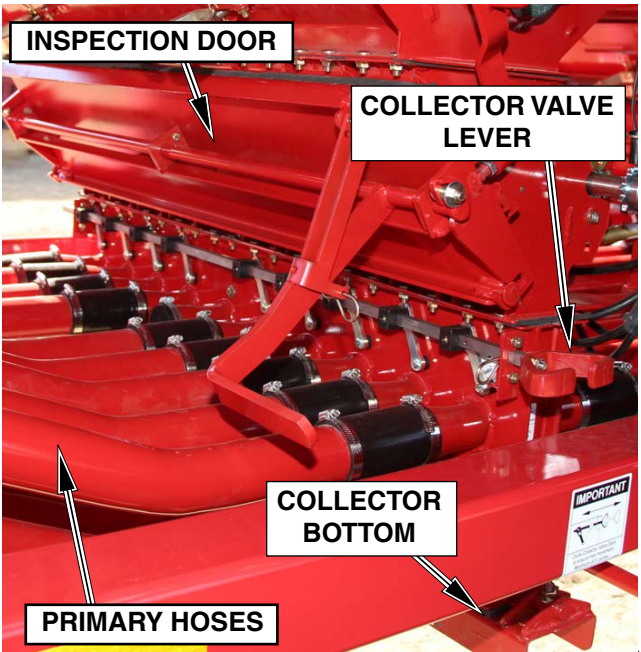

Double Shoot Shown

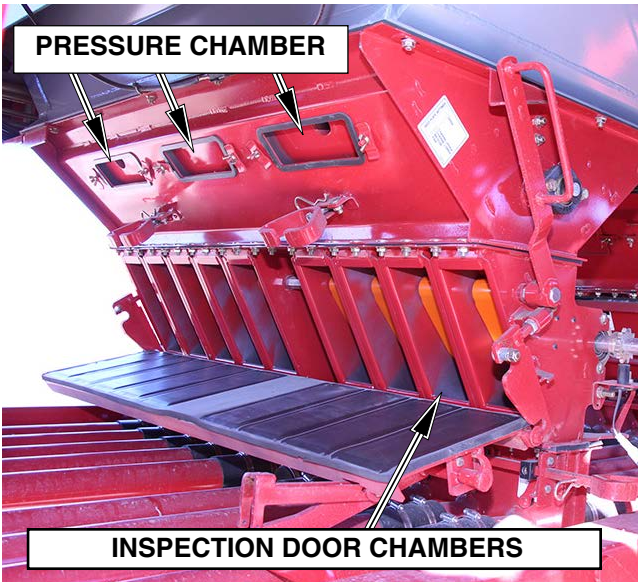
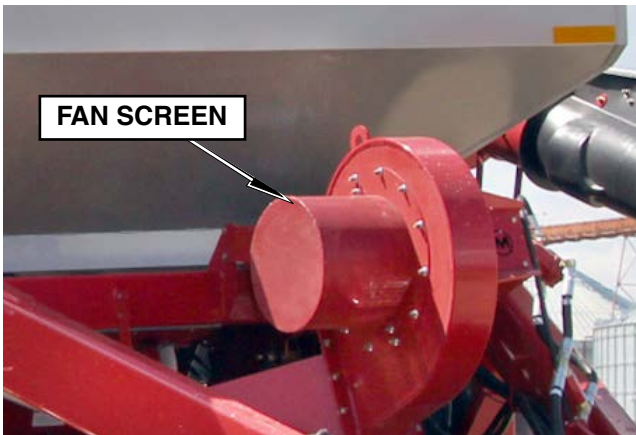

Maintenance

Lubrication

Greasing pivot points prevents wear and helps restrict dirt from entering. However, once dirt does enter a bearing, it combines with the lubricant and becomes an abrasive grinding paste, more destructive than grit alone.

- Apply new lubricant frequently during operation to flush out old contaminated lubricant.
- Use a good grade of **lithium based grease**.
- Use a good grade of machine oil.
- Clean grease fittings and lubricator gun before applying lubricant.

Refer to the following photos for grease fitting locations.

1. Drive Chains

- Oil every 50 hours.

2. Slow Speed Drive

- Grease every 50 hours.

3. Auger Pivot

- Grease every 100 hours.

4. Fan Bearing (17" Diameter Fan only)

- Apply 2 pumps of grease every 100 hours.

5. Quad Steer linkage

- Grease every 100 hours.

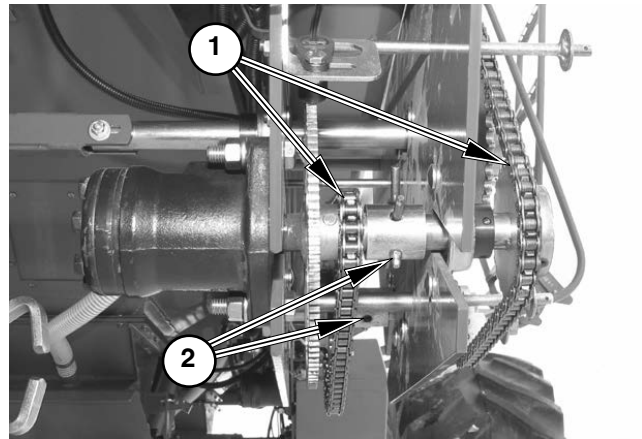

1 & 2 Transmissions

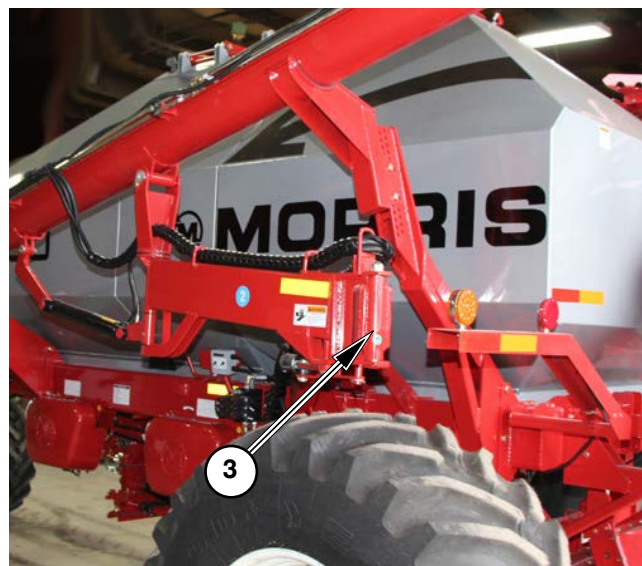

3. Auger Pivots

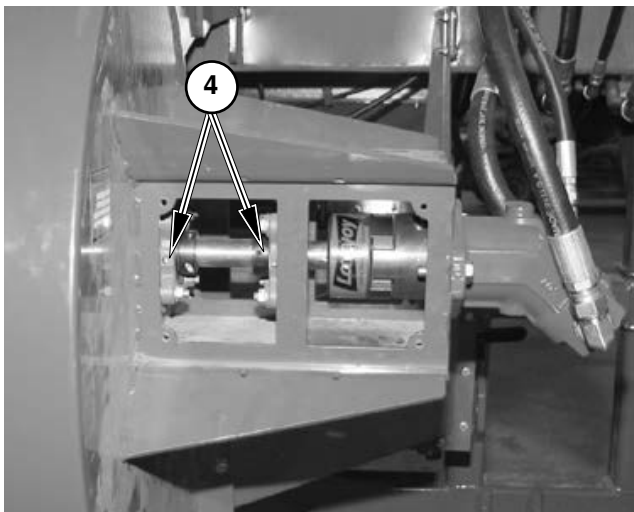

4. Fan Bearings



5. Quad Steer

Air Delivery System

General

The air delivery system of all air carts is extremely important for the proper metering of product to the openers. The metering system on all pressurized air carts is sensitive to air leaks. **Loss of tank air pressure could affect feed rates, which could become erratic or even stop.**

- Regularly check that all hoses are free from kinks or blockages throughout the day. To check for blockages raise seeding tool out of the ground and with the fan running engage meter drives with the Start/Stop button, rotating meter drives 4 to 5 times. Equal amounts of material should be deposited under each boot. If not, check the following for blockage:
 1. Seed openers and secondary hoses.
 2. Divider heads by removing access doors.
 3. Primary hoses and collectors.
 4. Metering wheels for damage to the flutes of the wheel.
- Keep fan inlet screen clear and free from debris.
- Place a plastic bag over the fan when the unit is not in use. This helps prevent moisture from entering the system.
- Check periodically and at the end of each season for air leaks at hose connections.
- Check periodically and at the end of each season for air leaks in the following areas:
 1. Tank lid seals.
 2. Metering body shaft seals.
 3. Metering body to tank seals.
 4. Collector to metering body seals.
 5. Fan to plenum.
 6. Plenum to collector.
 7. Inspection doors, for leaks and loss of seal memory.
 8. Collector door seals.
 9. Couplers between air cart and seeding tool.
 10. Access doors on divider heads.

Note: There must not be any excessive air leaks from the tank. This air leakage causes air turbulence in the tank which can result in inaccurate metering rates.

- Once a year check for wear of primary and secondary hoses.

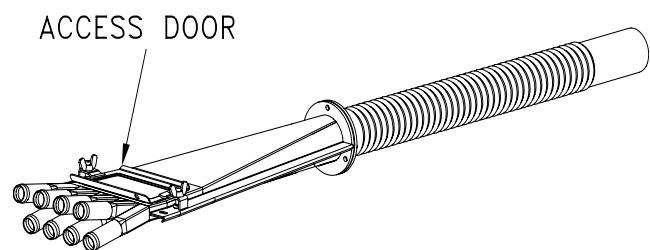
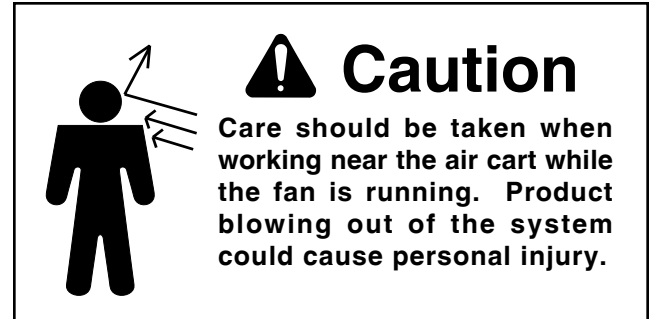

Note: Extended life can be obtained if the hoses are rotated 1/4 turn once a year.

Maintenance

Air Delivery System - Continued

Tank Lids

The lid seal is probably the area that sees the most abuse due to the activity associated with filling the tanks.

With each fill the lid seals should be inspected for cuts, abrasions, debris in the seal and ensure the seal is positioned properly on the steel rim around the tank opening.

Tank Lid Adjustment

Check Tank Lid tension on *all tanks* at beginning of each season and periodically during season for air leaks. The following checks and adjustments must be made to prevent air leaks from occurring:

- Check for any foreign material embedded into seal. Clean out foreign material from seal surface.
- Check seal for cuts and abrasions. If seal is cut or severely worn, then replace seal.
- Ensure seal is positioned properly on steel rim around tank opening.
- Use a 0-100 lb. (0-45 kg) spring scale to check the tank lid closing force. With the lid near the closed position, place one end of the scale *on* the tank lid handle. Pull down on the scale and note the maximum force it takes to hold the lid. The force needed to close the lid **must be 30 lbs (14 kg)**.
- Adjust the lid latch adjusting bolts as necessary. This will ensure that the lid is sufficiently tight and prevent any leaks.
- Re-check for leaks. If Lids still leak re-adjust latch bolts. Re-check for leaks.

Important

The product will not meter correctly if the lid is not tightly sealed or the tank is not pressurized.

Note: When air cart is not in use, leave lid latches loose to help maintain resilience of the seals.



Adjust the lid latch bolts to obtain a force of 30 lbs (14 kg) to close the lid.

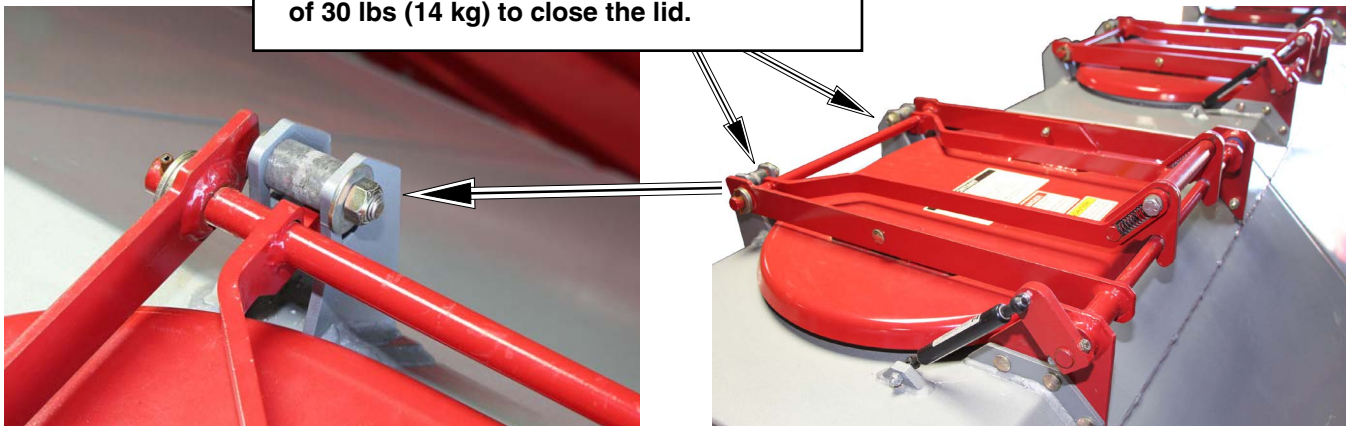

Air Delivery System - Continued

Inspection Door Adjustment

Check Inspection Door on *all metering bodies* at beginning of each season and periodically during season for air leaks. The following checks and adjustments must be made to prevent air leaks from occurring:

- Check for any foreign material embedded into seal. Clean out foreign material from seal surface.
- Check seal for cuts and abrasions. If seal is cut or severely worn, then replace seal.
- Ensure seal is positioned properly on steel rim around tank opening.
- Use a 0-100 lb. (0-45 kg) spring scale to check the door closing force. With the Door near the closed position, place one end of the scale *on* the Door handle. Pull down on the scale and note the maximum force it takes to latch handle lock. The force needed to latch handle lock **must be 30 lbs (14 kg)**.
- Adjust the door latch adjusting bolts as necessary. This will ensure that the lid is sufficiently tight and prevent any leaks.
- Re-check for leaks. If Doors still leak adjust latch bolts one or two more turns. Re-check for leaks.

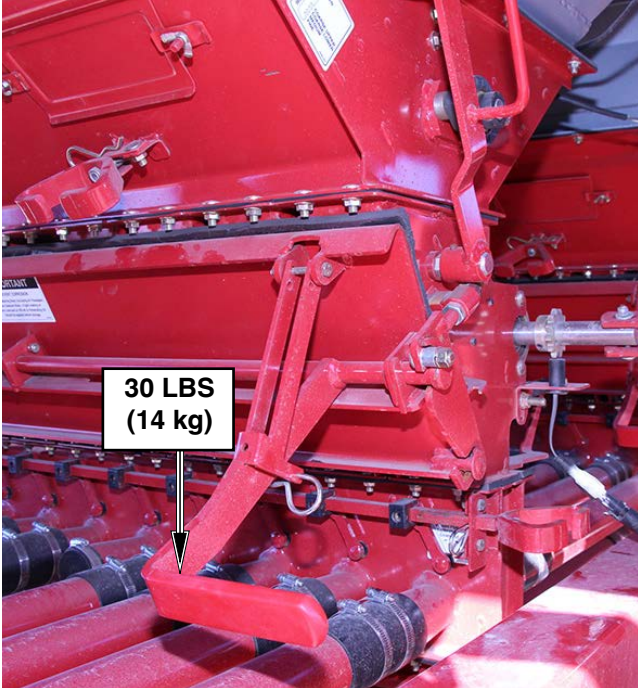

Important

The product will not meter correctly if the inspection door is not tightly sealed or the tank is not pressurized.

Maintenance

Air Delivery System - Continued

Clean Out Door Adjustment

Check Clean Out Door on all metering bodies at beginning of each season and periodically during season for air leaks. The following checks and adjustments must be made to prevent air leaks from occurring:

- Check for any foreign material embedded into seal. Clean out foreign material from seal surface.
- Check seal for cuts and abrasions. If seal is cut or severely worn, then replace seal.
- Ensure seal is positioned properly on steel rim around tank opening.
- Use a 0-100 lb. (0-45 kg) spring scale to check the Door closing force. With the Door near the closed position, place one end of the scale on the Door handle. Pull down on the scale and note the maximum force it takes to latch handle lock. The force needed to latch handle lock **must be 30 lbs (14 kg)**.
- Adjust the door latch adjusting bolts as necessary. This will ensure that the lid is sufficiently tight and prevent any leaks.
- Re-check for leaks. If Doors still leak adjust latch bolts one or two more turns. Re-check for leaks.
- In the open position, adjust the adjusting bolts as necessary to hold collector door away from the collector bottom.

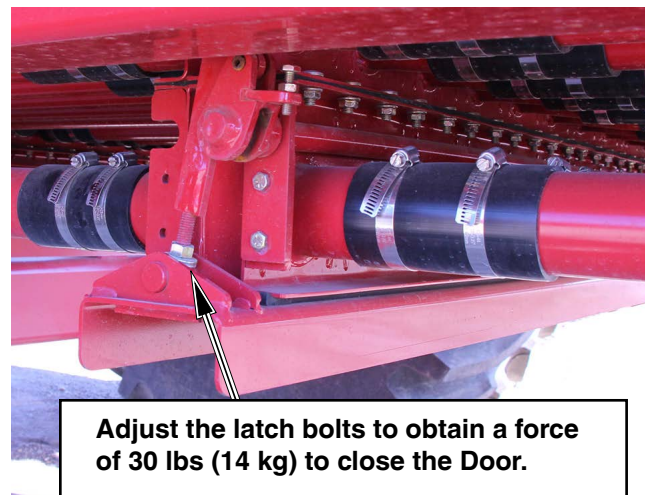

Important
The product will not meter correctly if the clean out door is not tightly sealed or the tank is not pressurized.

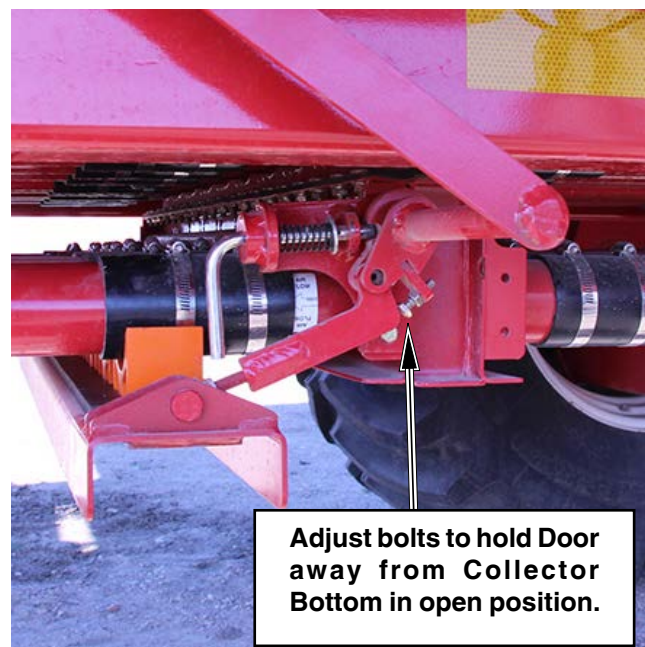

Air Delivery System - Continued

Air Leak Check

It is ***imperative that no excessive air leaks occur*** in the air cart tank. Air leaks could cause loss of tank air pressure affecting feed rates, which could become erratic or stop.

To prevent this from occurring, it is strongly recommended that a pressure test be conducted prior to seeding time. This can be performed very easily and simply by completing the following steps:

- Clean fan impeller and adjust tank lids.
- Disconnect the 2 1/2" diameter primary hoses from the rear of the seeding tool at the primary hose couplers.
- Install the blank off plate that is supplied with the air cart at each coupler. If the blank off plates are not readily at hand a piece of cardboard can be used in its place.
- Once the blank off plates have been installed, start the fan and run at 4,500 rpm.

Check the following areas for air leaks:

1. Tank lid seals.
2. Metering body shaft seals.
3. Metering body to tank seals.
4. Collector to metering body seals.
5. Fan to plenum and plenum to collector.
6. Inspection doors, for leaks and loss of seal memory.
7. Collector door seals.
8. Tanks union plate.

Air leaks can be detected by spraying a soapy water solution onto the seal area. If bubbling of soap occurs, the seal has a leak. Another method is to use your hand to feel for any air movement around the seal. This method requires a calm day, as the wind can make it difficult to detect a leak.

- If any of the above areas leak, remove the parts and replace the seal. Ensure upon reassembly that the parts are tightened sufficiently to prevent air leakage.
- Remove the blank off plates before using the air cart.

Once the pressure test is complete, check the following areas for air leaks:

9. Couplers between air cart and seeding tool.
10. Access doors on divider heads.

Important

It is imperative that no excessive air leaks occur in the air cart tank. Air leaks will lead to product bridging in the tank, thereby causing misses in the field.

Note: When air cart is not in use leave lid latches and inspection doors loose to help maintain resilience of the seals.

Excessive air leak definition:

When assessing air leaks, the use of hot soapy water serves as an effective detection method. The application of this mixture creates an environment for bubble formation, allowing for clear visual indicators of the severity of the leak.

An excessive leak becomes evident when a large bubble forms and bursts almost immediately upon contact with the soapy solution. This rapid collapse suggests that air is escaping at a significant rate, indicating an area that requires repair.

In contrast, a stable, small bubble that forms at a leak represents an acceptable scenario. These bubbles tend to hold their shape without quickly dissipating, implying that the airflow is minimal. Such leaks will not pose any threat to the integrity of the air system.

This distinction between excessive and acceptable leaks can aid maintenance personnel in diagnostics.

Maintenance

Air Delivery System - Continued

Fan

Debris can build up on the fan screen and blades causing reduced output of the fan. The lack of air flow even at higher fan speeds will cause material plugging of the air system.

The build up of material during operation can cause the following:

1. Fan rpm will increase without increasing oil flow to orbit motor.
2. Air cart distribution system plugging from a lack of air flow (Increasing fan rpm has little or no effect).

Fan Screen

- Ensure fan screen is clear of debris. Check periodically through the day.

Fan Impeller

The fan blades may become plugged under high humidity/dusty conditions/high insect counts.

Under severe conditions the fan blades should be inspected daily and cleaned as required.

Under normal conditions the fan should be inspected and cleaned at least once a season.

- Care should be taken in cleaning all fan blades thoroughly to restore the fans peak performance.
- Ensure that the balance clips located on the fan blades are not removed, as this will put the fan out of balance.

Storage

To prevent water entering the air system, cover the fan intake with a plastic bag, whenever the seeder is not in use.

Note: Be sure to remove fan cover prior to starting fan or serious damage could result to the fan.

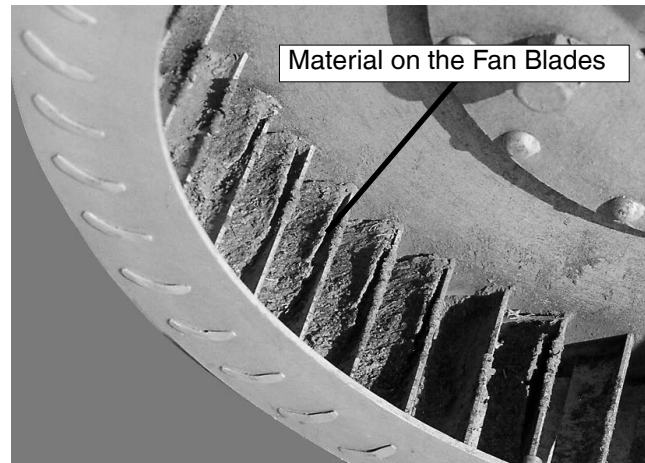

Note: Material build up on the fan blades could cause the fan to be out of balance. The added vibration of the out of balance impeller will reduce the life of the fan components.

Air Delivery System - Continued

Rotor Clearance

- Position rotor 1/8" (3 mm) from inlet.
- Check rotor alignment if tipped at an angle to the inlet adjust inner bearing on blower housing to achieve proper rotor to inlet concentricity.
- If rotor is square to inlet but not concentric to inlet, raise or lower the inlet on the mounting bolts.
- Spin rotor by hand to check for interferences, adjust as required.

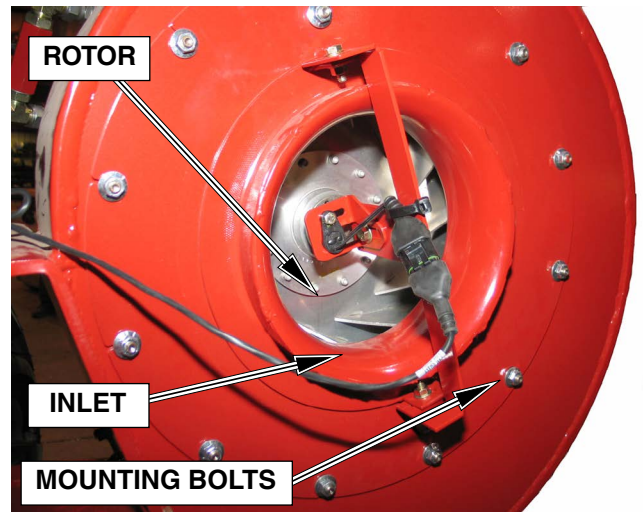

Hoses

Inspect air delivery hoses for wear and replace as required. Check areas where hoses may be exposed to moving parts such as hitch hinge area.

Also, inspect hoses for blockage as rodents/birds may nest in hoses that have not been properly capped during storage.

To optimize the 9 Series Air Cart air system the pressure across the inlets of the quick couplers should be balanced. To achieve this all primary hoses **must be equal in length or use equalizers** to achieve a balanced air system.

Consult with your MORRIS Dealer for assistance on hose lengths and location of equalizers.

Important

ALL primary hoses must be the same length or use equalizers to achieve a balanced air system.

Maintenance

Air Delivery System - Continued

Equalizers

The equalizers reduce the amount of primary hose required to balance the air system of the air cart.

- Equalizers are installed on the shorter primary hoses of the seeding tool. Consult with your MORRIS Dealer for assistance on hose lengths and location of equalizers.
- Check equalizers seasonally for wear. If flat section is gone replace equalizer.



Coupler on Seeding Tool

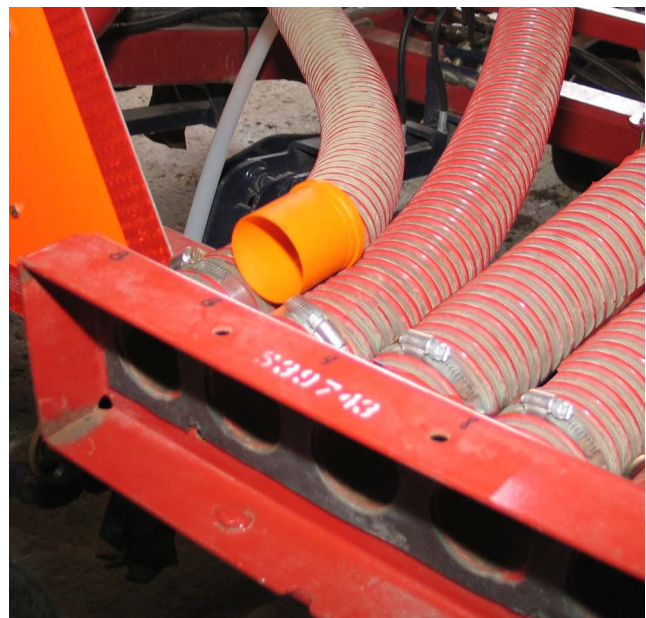

Insert Equalizers on Coupler Seeding Tool side

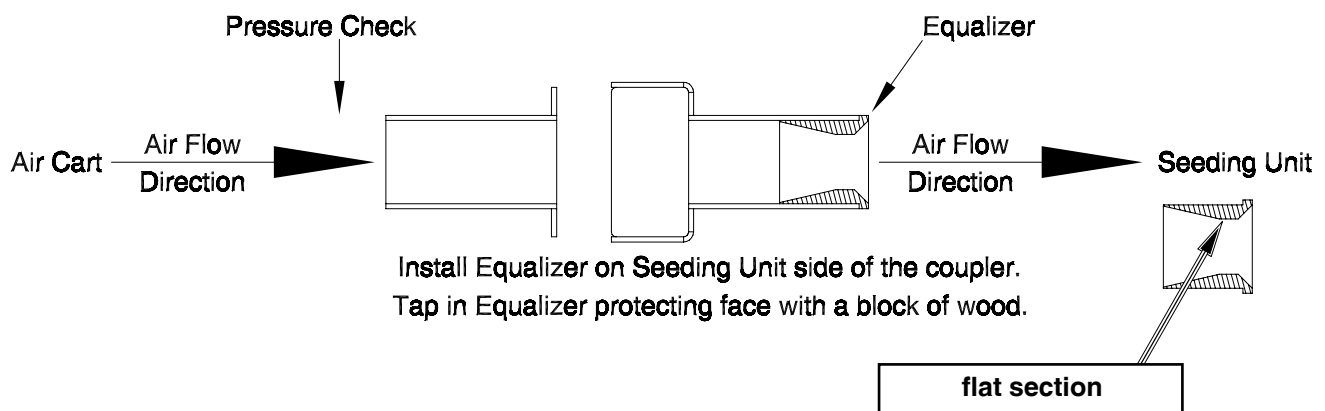

Hydraulic Orbit Motor

The motor requires no maintenance itself.

It does, however, require clean oil so the tractor hydraulic filters must be replaced regularly.

Repair/Replacement

- Remove orbit motor from the fan.

Note: The shaft should never be hammered on or forced in as this will result in motor damage upon startup.

- Remove the snap ring.
- Clean away paint then remove front cover.
- Push out the old shaft seal and press in the new one.

Note: The bearings should never be removed from the shaft as they are pretensioned to the shaft with the motor spinning.

- Replace the O-ring.
- Both the O-ring and shaft seal should be greased with “clean” grease.
- Care must be taken when the front cover is installed so the shaft seal is not damaged.
- Reinstall the snap ring.
- Fill the motor case with “clean” oil before running.

Note: Any time a motor is replaced the case must be filled with oil before it is started, if not, a bearing failure could occur.

Orbit Motor Coupler (17” Diameter Fan only)

- Urethane insert should be inspected every 100 hours or when greasing bearings.
- Inspect that there are no urethane filings or nicks or cracks in urethane insert.
- Ensure set screws in each half of the coupler are tight.

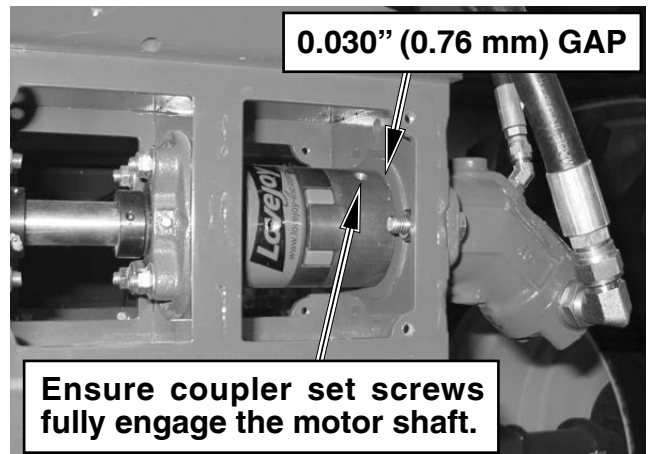
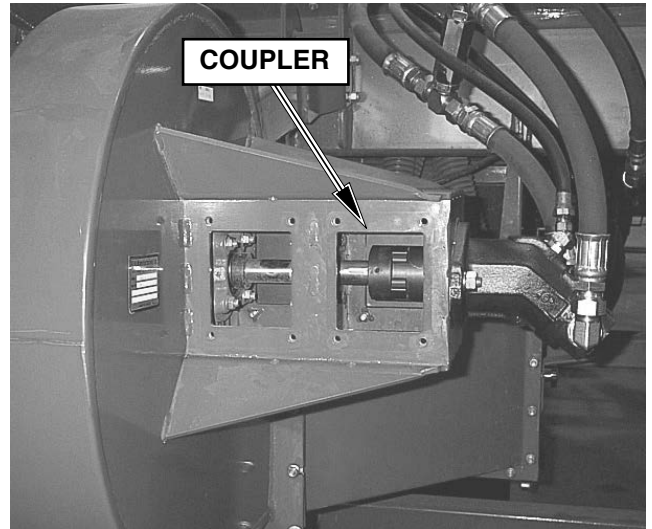
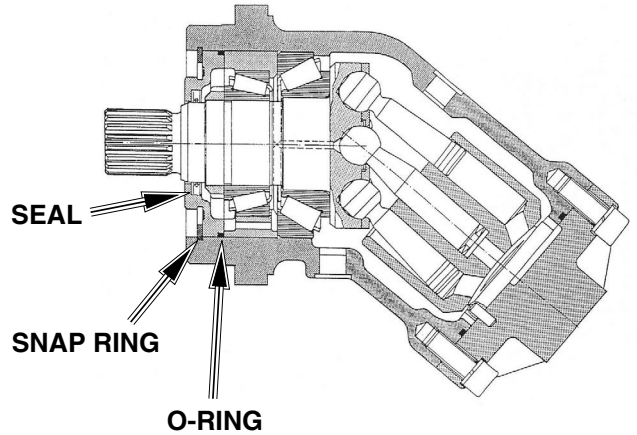

Maintenance

Hydraulics

Refer to Section 1 regarding hydraulic safety. In addition:

- Inspect hydraulic system for leaks, damaged hoses and loose fittings.
- Damaged hoses and hydraulic tubing can only be repaired by replacement. **DO NOT ATTEMPT REPAIRS WITH TAPE OR CEMENTS.** High pressure will burst such repairs and cause system failure and possible injury.
- Leaking cylinders - install a new seal kit.
- Fittings - use liquid Teflon on all NPT hydraulic joints. **Do not use liquid Teflon or Teflon tape on JIC or ORB ends.**
- Hydraulic Hose Connections - when connecting the hoses to the cylinders, tubing, etc. always use one wrench to keep the hose from twisting and another wrench to tighten the union. Excessive twisting will shorten hose life.
- Keep fittings and couplers clean.
- Check the Tractor Manual for proper filter replacement schedule.



Contact your nearest Dealer for genuine repair parts. Dealers carry ample stocks and are backed by the manufacturer and regional associations.

Caution

Dirt in the hydraulic system could damage O-rings, causing leakage, pressure loss and total system failure.

Note: Extreme care must be taken to maintain a clean hydraulic system. Use only new hydraulic fluid when filling reservoir.

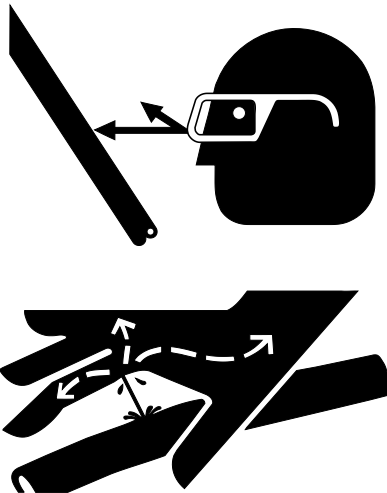

Warning

HIGH-PRESSURE FLUID HAZARD

To prevent serious injury or death:

- **Relieve pressure on hydraulic system before servicing or disconnecting hoses.**
- **Wear proper hand and eye protection when searching for leaks. Use wood or cardboard instead of hands.**
- **Keep all components in good repair.**

Wheel Bearings

- Shut tractor off and remove key.
- Block wheel on tractor.
- Raise the air cart wheels enough to clear the surface.
- Securely block air cart frame.
- Remove wheel from hub.
- Remove the dust cap, cotter pin, and the slotted nut and washer.
- Be careful when pulling the hub off as not to drop the outer bearing.
- Clean spindle and bearing components with solvent.
- Inspect for wear on bearings, spindle and cups. Replace parts as required.
- Do not reuse old seals. Use only new seals when assembling.
- Pack inner hub with bearing grease.
- Be sure bearing and cup are dry and clean.
- Work grease into the bearing rollers, until each part of the bearing is completely full of grease.
- Install inner bearing and cup first, then press new seals in place.
- Place hub on spindle.
- Install outer bearing, washer and slotted nut.
- Tighten nut while turning the wheel until a slight drag is felt.
- Back nut off one slot and install a cotter pin. Bend cotter pin up around nut.
- Pack grease inside the dust cap and tap into position.

Important

Check wheel bearings for play every
5,000 acres (2,000 hectares)
or yearly, whichever occurs first.
Tighten as required.

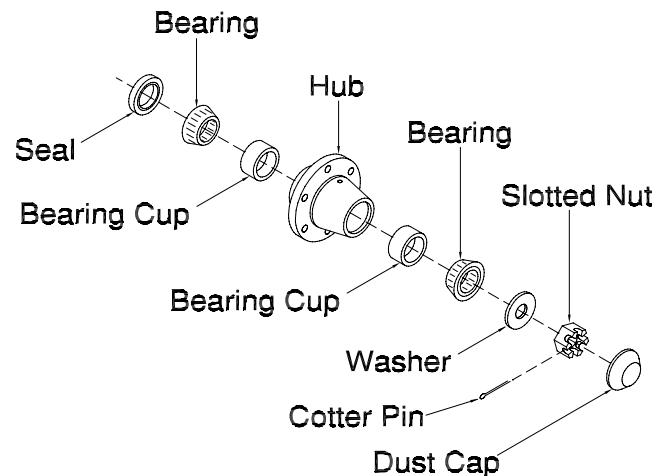

Maintenance

Quad Steer

- Periodically check the 1 x 3 bolts, flatwashers and locknuts attaching the axle and pivot assembly. Torque **Grade 5** bolts to 590 lb-ft.
- Periodically check the 3/4 x 3 bolts, flatwashers and locknuts attaching the axle and pivot assembly. Torque the 3/4 **Grade 5** bolts to 270 lb-ft. Torque the 3/4 **Grade 8** bolts to 375 lb-ft.
- Toe-in adjustment should be 1/16" to 1/8" maximum.
- Grease all fittings every 100 hours.



Important

Retorque wheel nuts to 450 lb-ft (610 Nm) after first fifteen minutes of operation and every fifteen minutes for the next 2 hours. Check periodically afterwards.

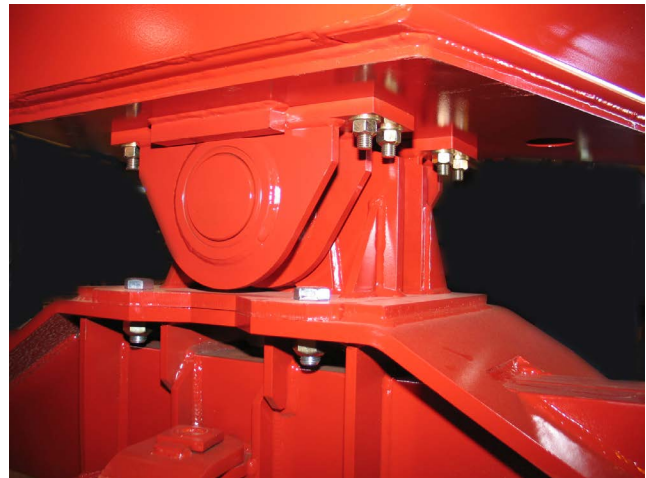

Dual Wheels

Below torques are for 520/85R38 and 800/65R32 tires.

- Torque wheel nuts as follows:
 - 3/4 wheel bolts to 450 lb-ft (610 Nm)
 - 7/8 wheel bolts to 525 lb-ft (712 Nm)
 - 22 mm wheel bolts to 500 lb-ft (678 Nm)

Important

Retorque wheel nuts after first fifteen minutes of operation and every fifteen minutes for the next 2 hours. Check periodically afterwards.



Dual Wheel Assembly

Dual Wheel 9800 and 91000 - 38 Rims

Rim Identification

There are two versions of 38 inch dual wheels used on the 9800 and 91000 Carts for the 800/70R38 and 850/80R38 tires

Titan Rim

Rim center is square with 10 inner holes and 16 outer holes.

These rims bolt directly to the 10 bolt hub and uses an inner and outer clamping plates on the outer 16 holes.

- Torque the M22 nuts to 500 lb-ft (678 Nm)
- Torque the M24 nuts to 800 lb-ft (1085 Nm)

See page 6-20 for details.

Moveero (GKN) Rim

Rim center is dished with 20 outer holes.

These rims incorporate a hub adapter with 10 inner holes and 20 outer holes to attach to the hub.

- Torque the M22 nuts to 500 lb-ft (678 Nm)
- Torque the M24 bolts to 590 lb-ft (800 Nm)

See page 6-22 for details.

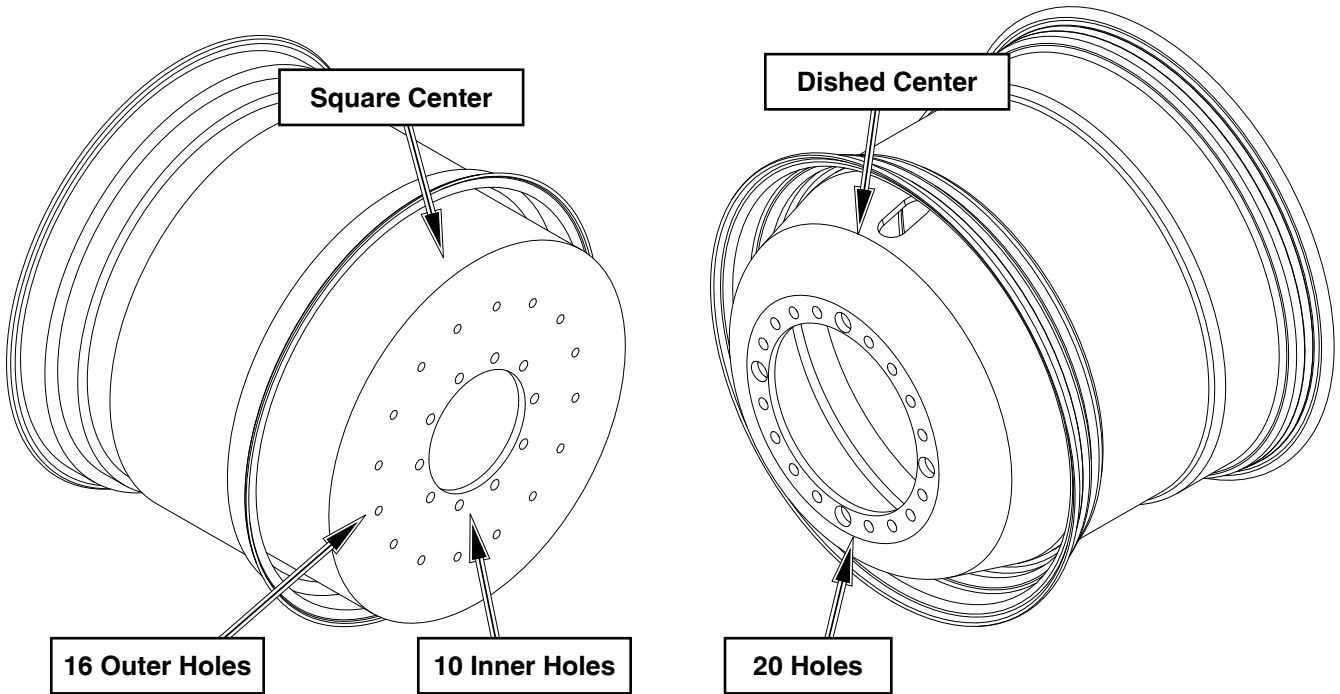

Maintenance

Dual Wheel 9800 and 91000 - 38 Rims - Continued

Titan Rim

The illustration below shows the components of the clamping plates, see following page for details on removing and installing tires.

⚠ Caution

Tire replacement should be done by trained personnel using the proper equipment. Tires are heavy and could fall as soon as the wheel nuts are removed.

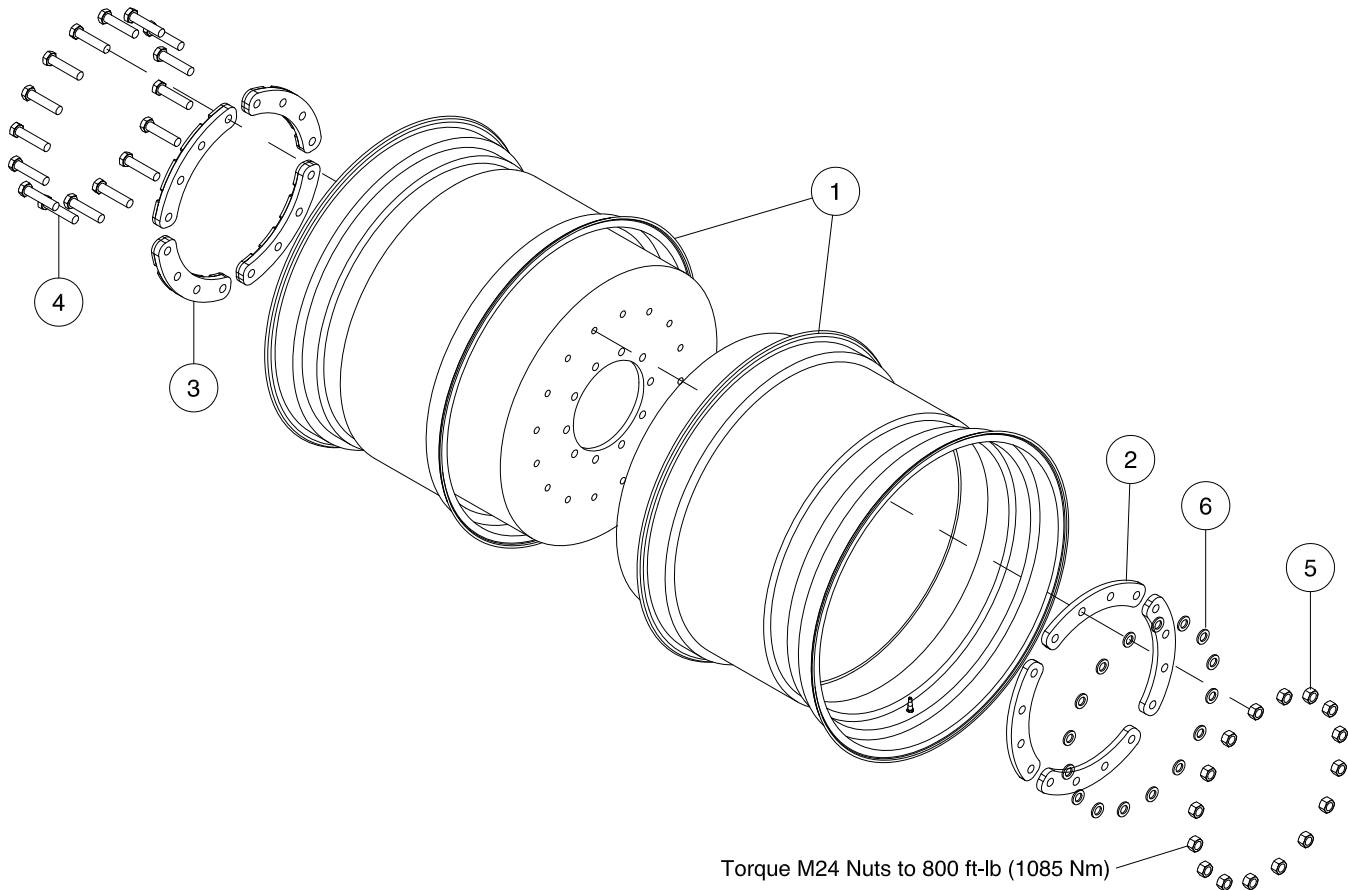

Item	Part No.	Description	Qty
1	N69465	Rim - Dual - 28 x 38 Rim (10 inner bolts and 16 outer bolts)	2
2	N69613	Clamp Plate - Outer	4
3	N72184	Clamp Plate - Inner	1
4	N72187	Hex Bolt - M24-3.00 x 110 mm Lg Gr10.9	16
5	N72188	Hex Nut - M24-3.00 Gr10.9	4
6	N72189	Washer Hardened - M24 (25mm ID x 44mm OD x 4mm Thick)	16

Dual Wheel 9800 and 91000 - 38 Rims - Continued

Titan Rim - Continued

Removal and Installation

- Empty all product from air cart tanks.
- Park the air cart on a flat and level area of hard ground.
- Shut tractor off and remove key.
- Block all of the air cart tires to ensure the unit does not move.
- Loosen the wheel nuts while the air cart is still on the ground.
- Raise the air cart tires enough to clear the surface.
- Securely block air cart frame.
- Remove one clamping segment at a time from the outer 16 hole pattern. Remove the bolts and backing plates from inner rim.
- Position a dual wheel dolly to support both tires and block to prevent movement of the dolly.
- Remove the nuts from the inner 10 holes.
- Tires can now be removed slowly with the dolly.

Reverse process to reinstall tires to cart.

10 Bolt Hub Torque

- Dry torque the M22 nuts to **500 lb-ft (678 Nm)** following the sequence in the illustration. A 4:1 torque multiplier is recommended for ease of operation. **(Do not use lubricant)**

16 Bolt Torque

- Dry torque the M24 nuts to **800 lb-ft (1085 Nm)** following the sequence in the illustration. A 4:1 torque multiplier is recommended for ease of operation. **(Do not use lubricant)**

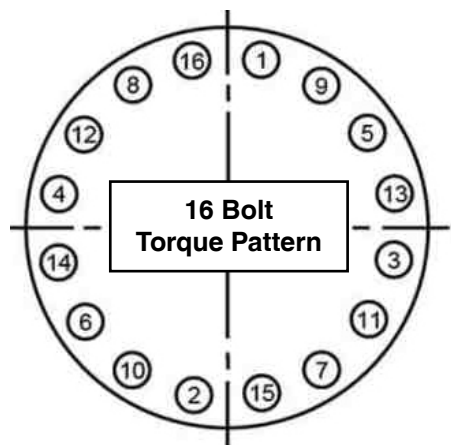
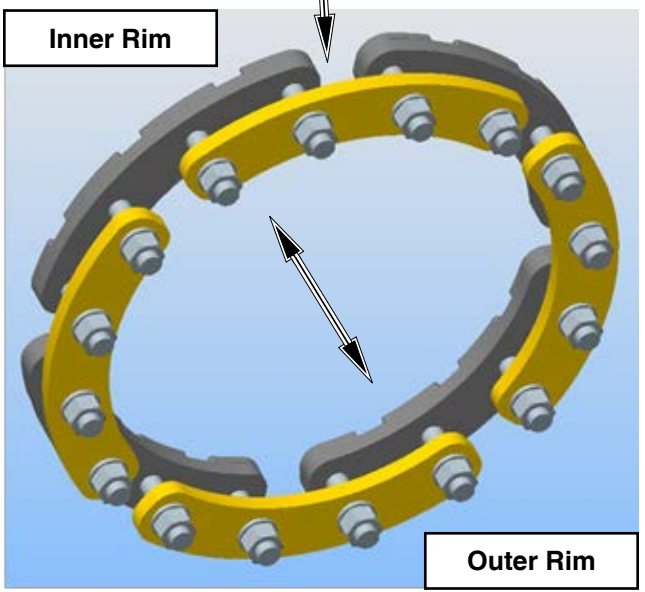
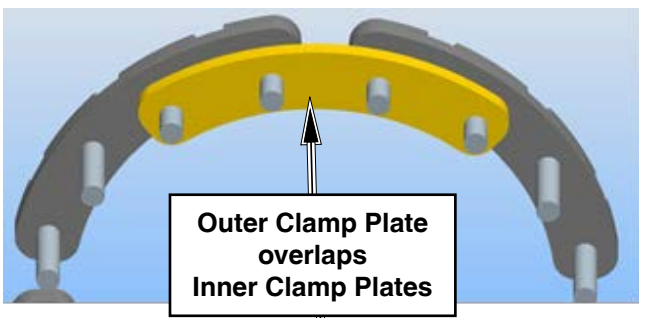
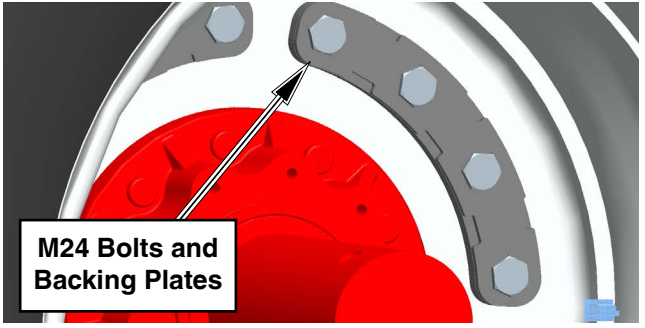

Maintenance

Dual Wheel 9800 and 91000 - 38 Rims - Continued

Moveero (GKN) Rim

The illustration below shows the components of the hub adapter, see following 3 pages for details on removing and installing tires.

⚠ Caution

Tire replacement should be done by trained personnel using the proper equipment. Tires are heavy and could fall as soon as the wheel nuts are removed.

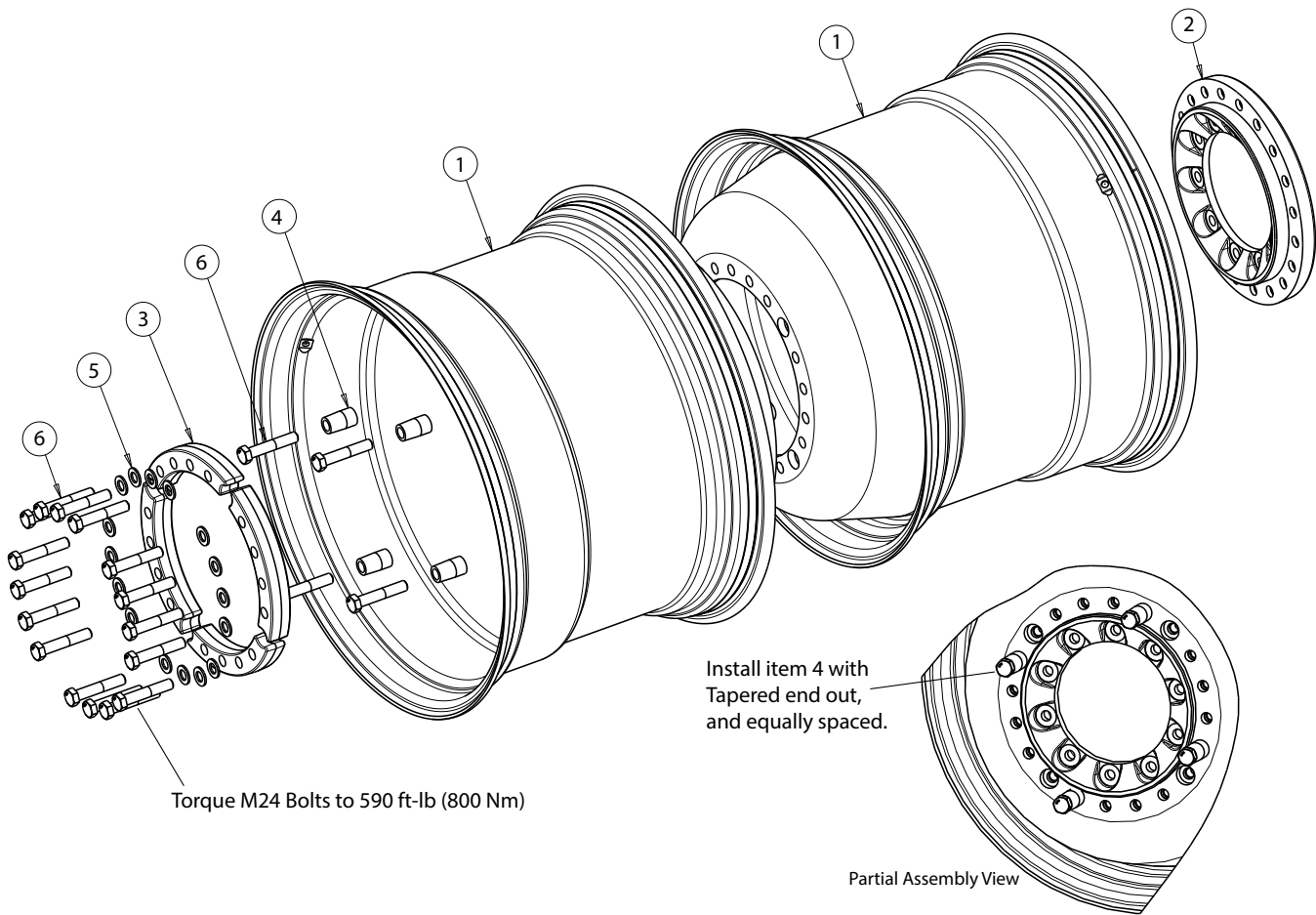

Item	Part No.	Description	Qty
1	N71470	Dual Rim - 38 x DW27B - GKN - (20 bolts).....	2
2	N71475	Dual Wheel Hub Adapter - GKN.....	1
3	N71473	Hub Adapter Spacer Segment - GKN	4
4	N71469	Hub Adapter Alignment Bushing - GKN	4
5	N71476	Washer M24 Hardened - GKN	16
6	N71471	Hex Bolt - M24-3.00 x 130 mm Lg Gr10.9 - GKN.....	20

Dual Wheel 9800 and 91000 - 38 Rims - Continued

Moveero (GKN) Rim - Continued

Removal and Installation

- Empty all product from air cart tanks.
- Park the air cart on a flat and level area of hard ground.
- Shut tractor off and remove key.
- Block all of the air cart tires to ensure the unit does not move.
- Loosen the wheel nuts while the air cart is still on the ground.
- Raise the air cart tires enough to clear the surface.
- Securely block air cart frame.
- Position dual dolly around wheel to be removed and block to prevent movement of the dolly
- Remove wheel from hub.

Outer Dual Tires:

Outer Dual removal:

- Remove one clamping segment at a time, leaving the bolts with the alignment bushing in place located in the large holes in the rim.
- The alignment bushings will ensure the inner dual is held on when the outer dual is removed.
- With all four clamping segments removed the outer dual can slide off the alignment bushings.

Outer Dual installation:

- Position the larger holes in the outer dual over the alignment bushings and slide into position.
- Reinstall clamping segments with the hardened washers and M24 bolts.
- Torque the M24 Bolts to 590 lb-ft (800 Nm) See next page for torque sequence details.

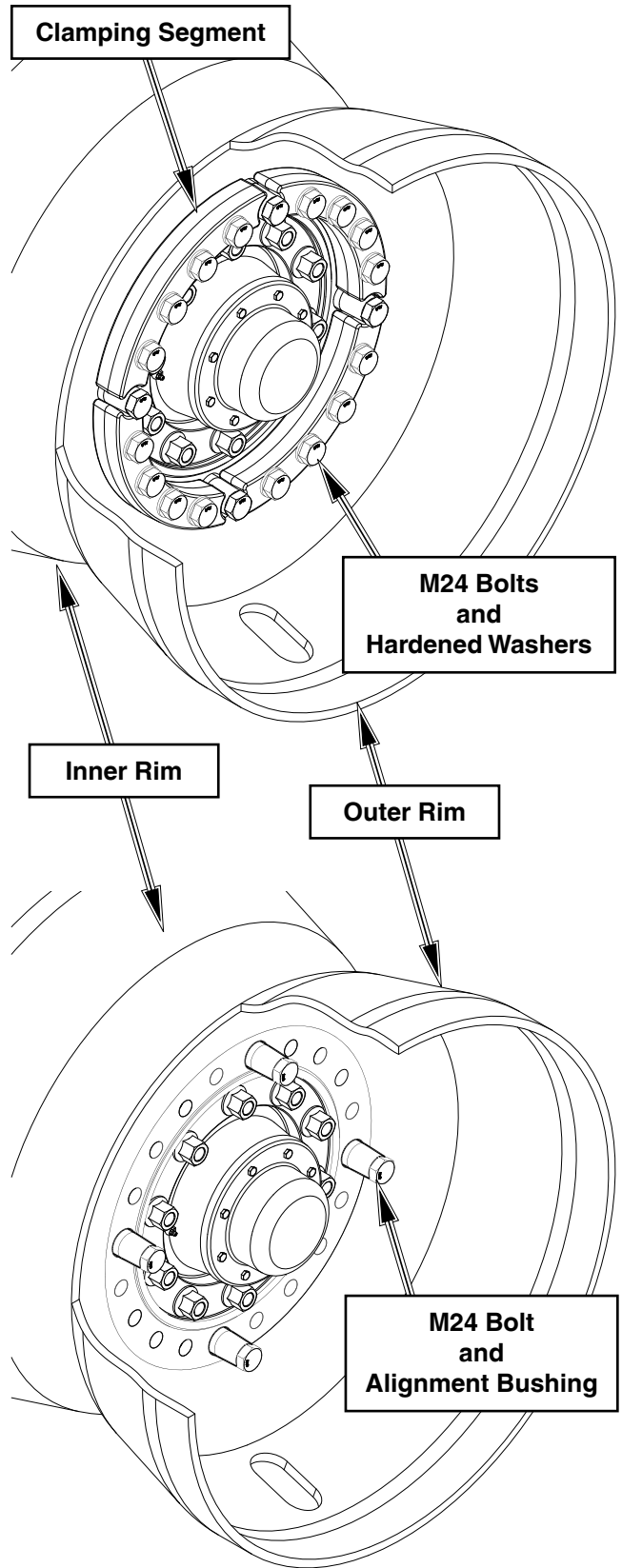

Caution

Tire replacement should be done by trained personnel using the proper equipment. Tires are heavy and could fall as soon as the wheel nuts are removed.

Maintenance

Dual Wheel 9800 and 91000 - 38 Rims - Continued

Moveero (GKN) Rim - Continued

Inner Dual Tires:

Inner Dual removal:

- Remove outer dual as outlined on previous page.
- Remove the M24 bolts and alignment bushings.
- Remove inner dual from dual wheel adapter.

Inner Dual installation:

Install the new dual using the following process:

- Position the inner dual on the lip of the adapter.
- Install the alignment bushings (tapered end out) with M24 bolts in the small holes clockwise of large holes.
- Install the outer dual tire as outlined on previous page.
- Position the larger holes in the outer dual over the alignment bushings and slide into position.
- Reinstall clamping segments with the hardened washers and M24 bolts.
- Torque the M24 Bolts to 590 lb-ft (800 Nm) See next page for torque sequence details.

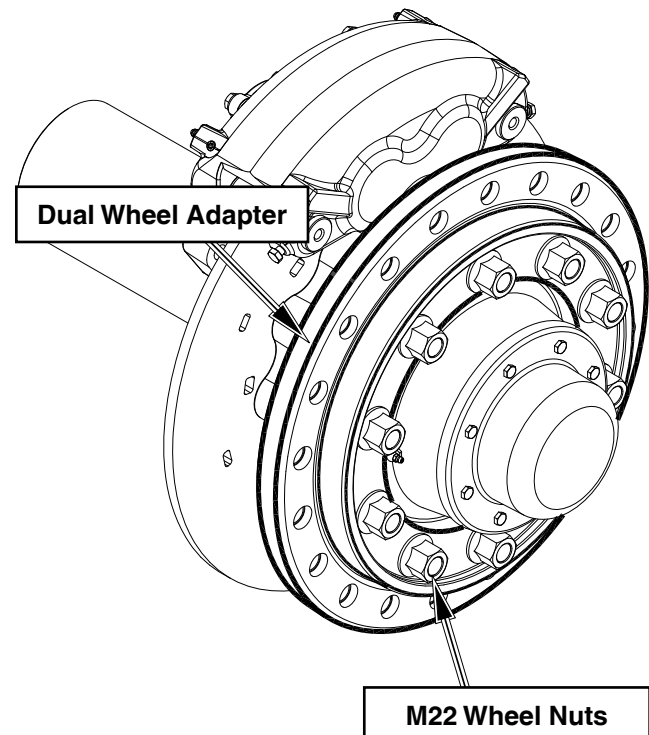
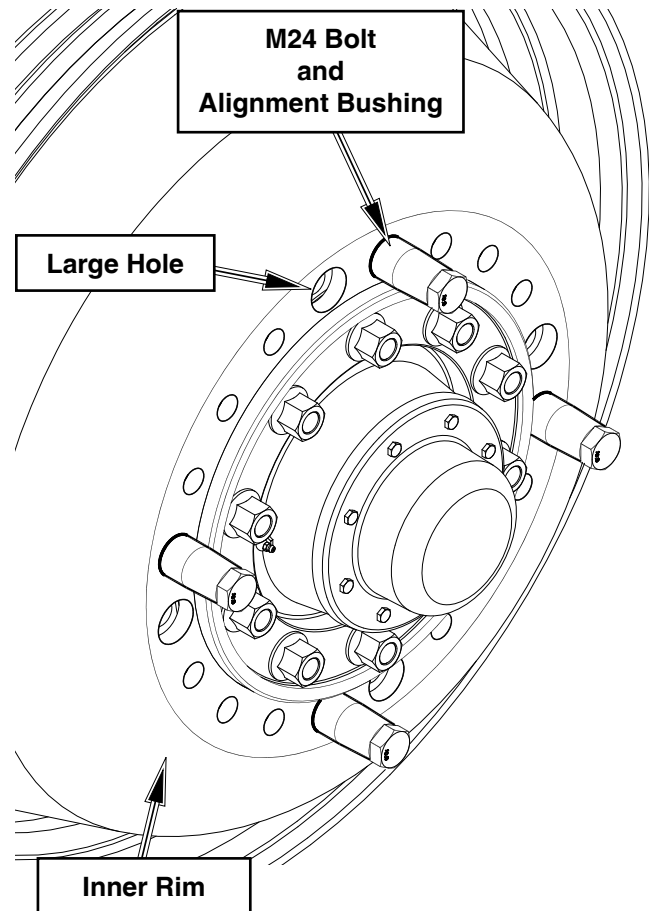

Caution

Tire replacement should be done by trained personnel using the proper equipment. Tires are heavy and could fall as soon as the wheel nuts are removed.

Dual Wheel 9800 and 91000 - 38 Rims - Continued

10 Bolt Torque Pattern

- Dry torque the M22 nuts to **500 lb-ft (678 Nm)** following the sequence in the illustration. A 4:1 torque multiplier is recommended for ease of operation. **(Do not use lubricant)**

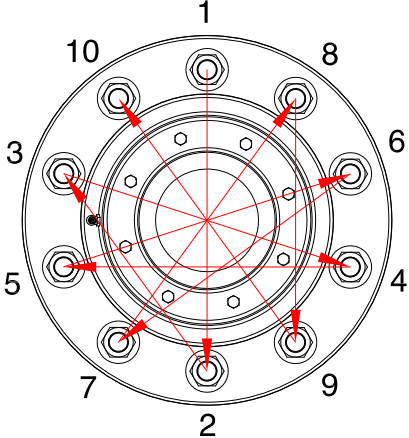

20 Bolt Torque Pattern

- Dry torque the M24 Bolts to **590 lb-ft (800 Nm)** following the sequence in the illustration. A 4:1 torque multiplier is recommended for ease of operation. **(Do not use lubricant)**

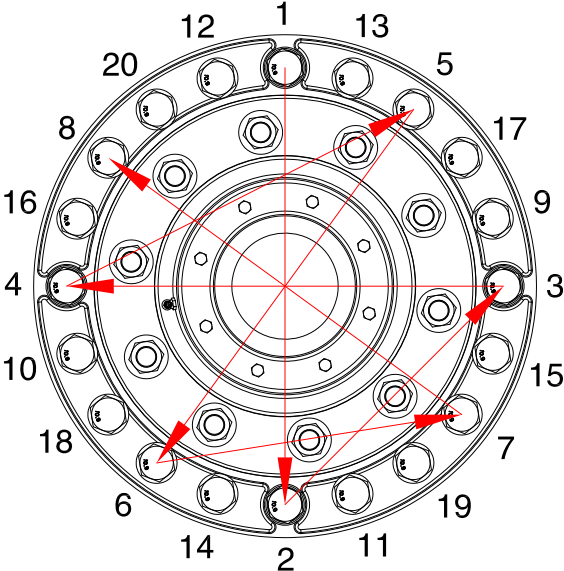

Maintenance

Seed Plate Adjustment

Ensure that when the adjustment handle is in the Fine position notch that the seed plates are tight up against the metering wheels spacers.

If this does not occur adjust the adjustment plate by loosening the bolts that attach the plate to the metering body and slide the plate accordingly.

This adjustment must be done without product in the tank or with the slide gates closed and the metering body cleaned out.

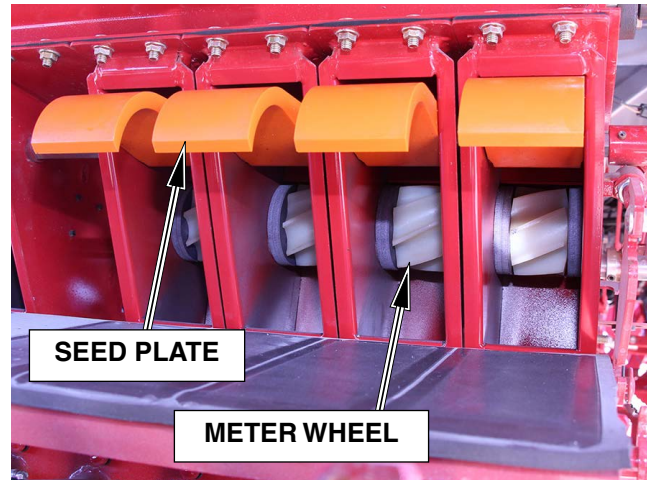

Ensure Metering is Free of Debris

Important

Do not try and close the seed plates with the product in the metering body as damage can occur from the product being squeezed between the wheels and seed plates.

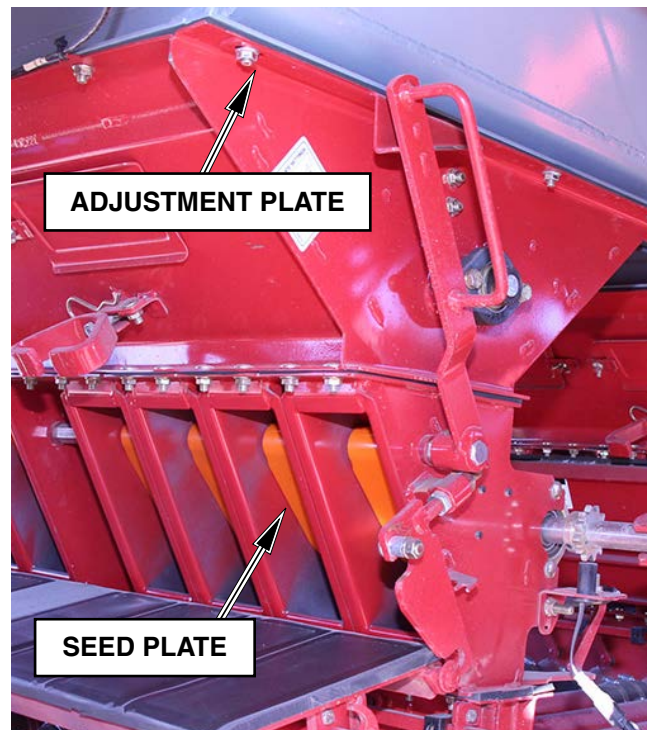

Tie Rod - Tow Between

On the 9365 and 9450 Tow Between Carts the Tie Rod torque procedure as follows:

1. Tighten the nut up to the frame plate.
2. Record the torque just before contacting the plate. (Initial Torque)
3. Add 100 lb-ft (136 Nm) to the recorded torque and tighten the nut against the plate at this torque.

Check at 10 and 50 hours and periodically afterwards.

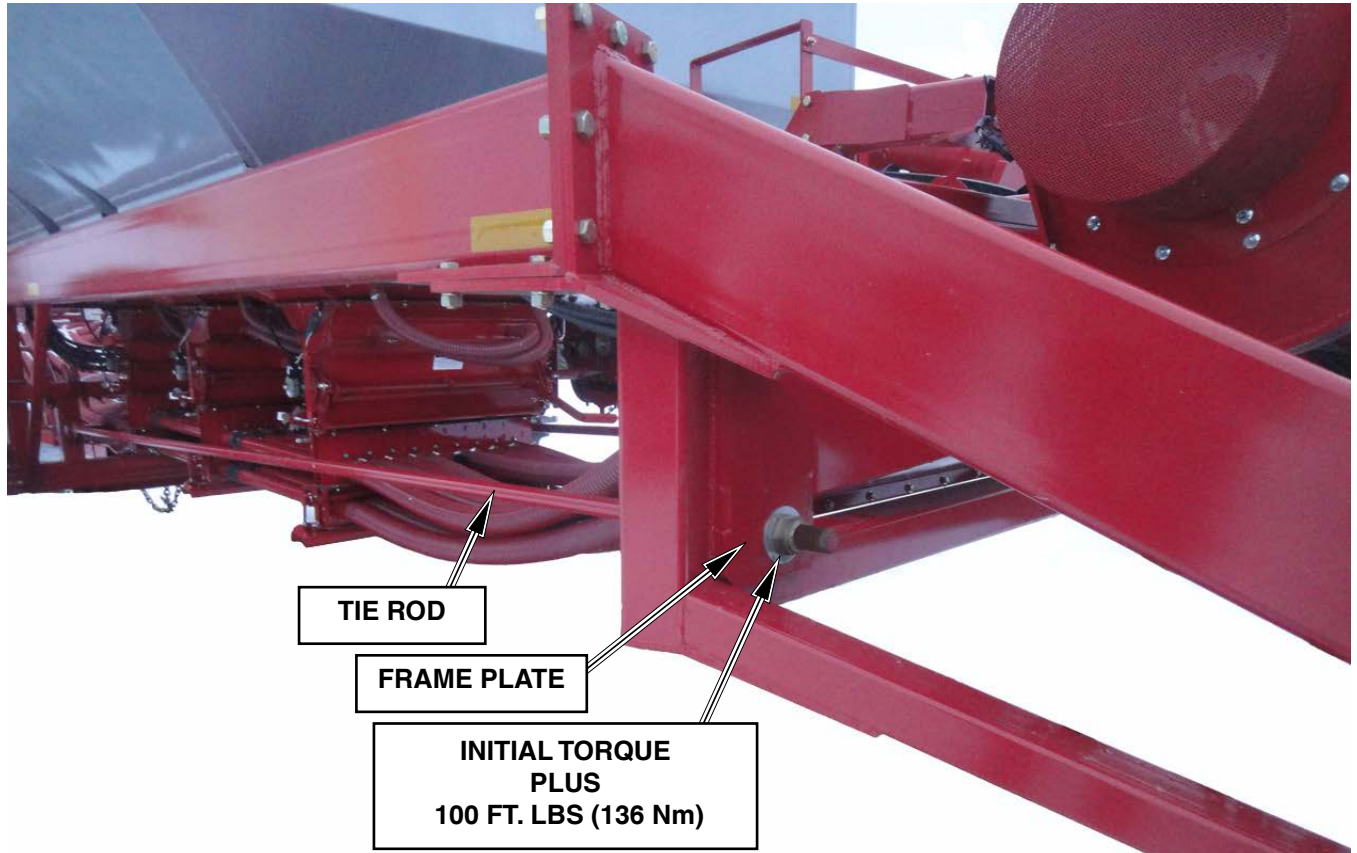

Maintenance

Conveyor

Squaring One End of Belt

Lay a framing square along a straight edge of the belt to make a cut line on the back side of the belt. Cut belt along this line using a utility knife. If the belt has uneven edges, create an average centerline, and square off of this line. **A clean, straight, square cut is required for the belt to run true on the pulleys.**



Squaring Belt

Installing Belt Splice

1. Center and press the fastener strip on the belt.
2. Press the Application Tool on the center of fastener strip with the cam lever in the "up" position.
3. Lower cam lever. Strike staple driver on each staple until staple clinches on Application Tool anvil.
4. Raise cam lever and move tool to outer edge of belt.
5. Clinch staples. Repeat until all staples are complete.

Continued on next page . . .



Centering strip on belt

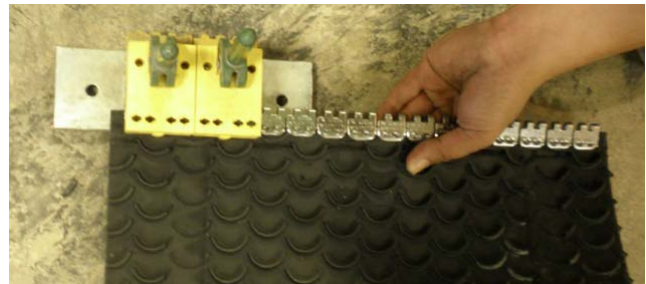

Cam lever up

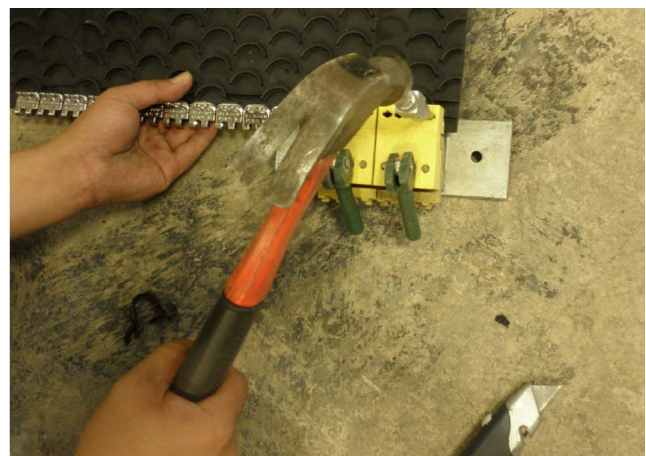

Cam lever down and strike staple

Conveyor - Continued

Installing Belt Splice - Continued

6. Place the splice over a piece of flat steel and clinch each staple with a hammer. Turn belt over and peen staple ends flush with surface of fastener strip.
7. Bend fastener strips until they break apart.
8. Follow the procedure above for installing the second belt splice.
9. Insert the hinge pin. Crimp the pin washers on the ends of the pin using pliers.
10. Tighten the belt tensioning bolts to 20-23 Lb-ft. so that each side is adjusted equally.
11. Re-assemble the tail end Door Assembly.



Clinch staples



Bend fastener strips

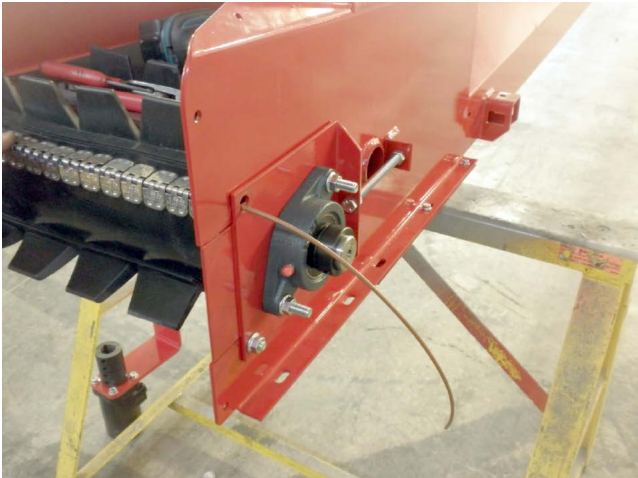

Insert hinge pin



Crimp pin washers.

Maintenance

Conveyor - Continued

Installing Belt into the Conveyor

1. Remove the Tail End Door Assembly.
2. Slide a fish tape from the discharge end to the tail end of the conveyor. Pull a rope with a belt splice back through the conveyor. Fasten the conveyor belt to the rope splice, and pull the belt into the top of the conveyor with the rope.
3. Using the fish tape, pull the bottom side of the belt through the conveyor. **Make sure the belt is free of extra twists before pulling it in.**
4. Check to see that the idler is all the way forward (toward the drive end).
5. Pull the belt up tight at the discharge end and cut off the excess length so that there is 1/2" of overlap after the end is squared.



Remove tail



Idler forward

Conveyor - Continued

Tracking the Belt

1. Basic rule: ***the belt moves toward the end of the roller that it contacts first.***
2. Rollers must be square with the housing and parallel to each other.
3. Belt tension must be great enough to prevent slippage. Tension to 20-23 lb-ft. on adjustment bolts

CAUTION: Make sure everyone is clear of machine before running.

4. Run the conveyor. Check to see that the belt runs centered on the drive roller. Turn off the machine. Adjust drive roller if necessary.

WARNING: Do not run the machine while adjusting. Failure to heed may result in personal injury or death.

5. To adjust drive roller, loosen the four nuts on the bearing holder plate, and the jam nut on the threaded adjuster. Retighten after adjusting is complete.

CAUTION: Make sure everyone is clear of machine before running.

6. Run the machine for two minutes. Make sure belt runs centered on drive pulley.
7. Open the Tail End Door to view the idler.
8. Run the machine. Check to see that the belt is running centered on the idler roller. Turn the machine off.

WARNING: Do not run the machine while adjusting. Failure to heed may result in personal injury or death.

9. If adjustment is necessary, adjust the tensioning bolts on the idler housing to 20-23 lb-ft torque.
10. Check adjustment by running the machine. Make sure belt runs centered on idler pulley. The clearance between the belt and the housing should be the same on both sides.
11. Close the Tail End Door when complete.

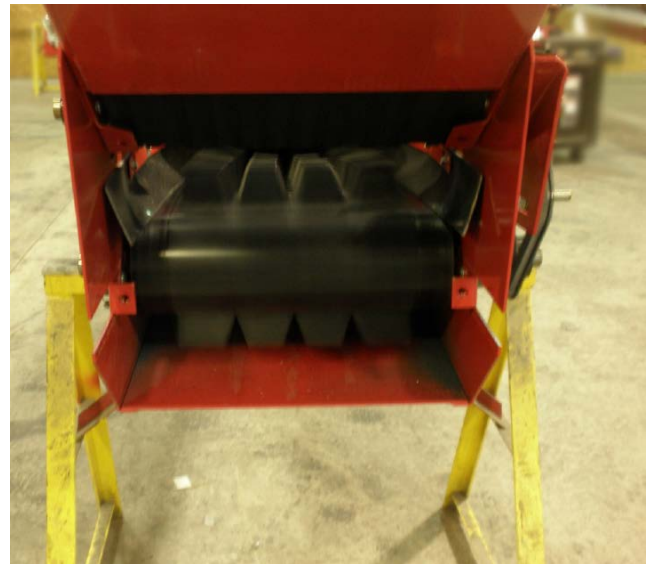

Open tail and center belt on rollers

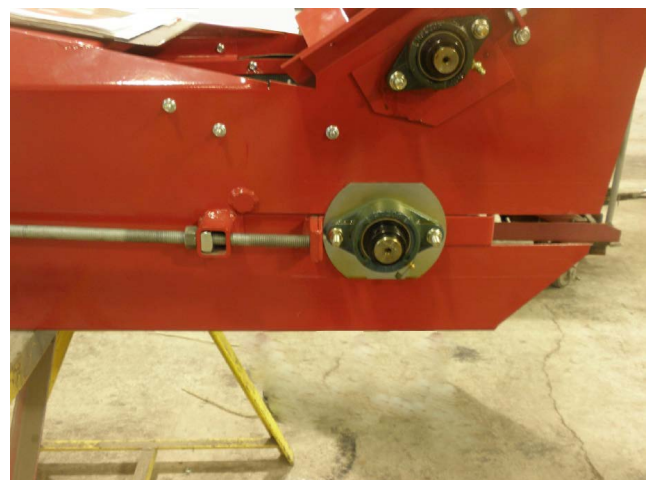

Left tensioning bolt



Right tensioning bolt

Maintenance

Conveyor - Continued

Conveyor Belt Adjustment

Belt tension and tracking will need periodic adjustment. Follow the guidelines under “Tracking the Belt” to make adjustments.

Important

Belt Alignment and Belt Tension should be checked periodically.

Belt damage will occur if alignment or tension has not been maintained.

Belt tension should be 23 lb-ft of torque on adjustment bolts.

Belt should be tracked to be centered on the idle and drive roller.



Bearings

All drive shafts are supported by self-aligning, sealed ball bearings which have been packed at the factory and require no further lubrication. There is no adjustment to be made to the bearings, but check that the retainers are firmly fastened to the bearing stand. Also check that the setscrews in the lock collars are tight against the drive shaft.

Conveyor Belt Care

It is recommended that the conveyor belt be washed off and the tail end be cleaned out at the end of the season. This will help prevent material residue from building up and causing damage to the belt.

Conveyor - Continued

Conveyor Assembly

25 foot Conveyor shown

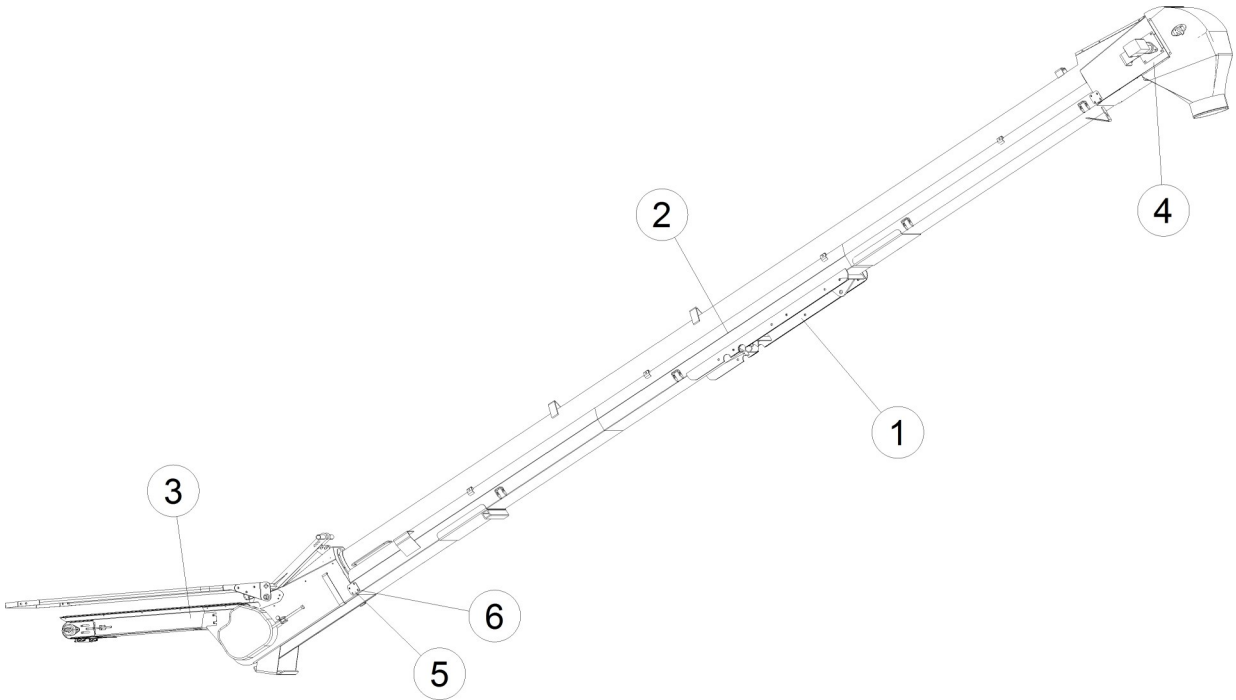

Item	Part No.	Description	Qty
1	81079-00-MR	Carrying Rack.....	1
2	81080-00-MR	Tube Assembly - 25'.....	1
3	81081-00	Lower End Group.....	1
4	81082-00	Upper End Group.....	1
5	N65065	Plate - Connector - 81091-01-MR.....	4
6	N65066	Plate - Spacer - 81092-01-MR.....	2
Items Not Shown			
	N62349	Belt, Rubber Cleated - 16 x 51 ft 4 inches - for 25' conveyor - 24550-30.....	1
	N53224	Belt Splice Kit - 16 Cleated Belt - 24387-15.....	1
	N58827	Splice Pin - 16 Belts - 24121-75.....	1
	N65795	Canvas - 81011-02.....	1

Maintenance

Conveyor - Continued

Lower End Group

23 foot Conveyor

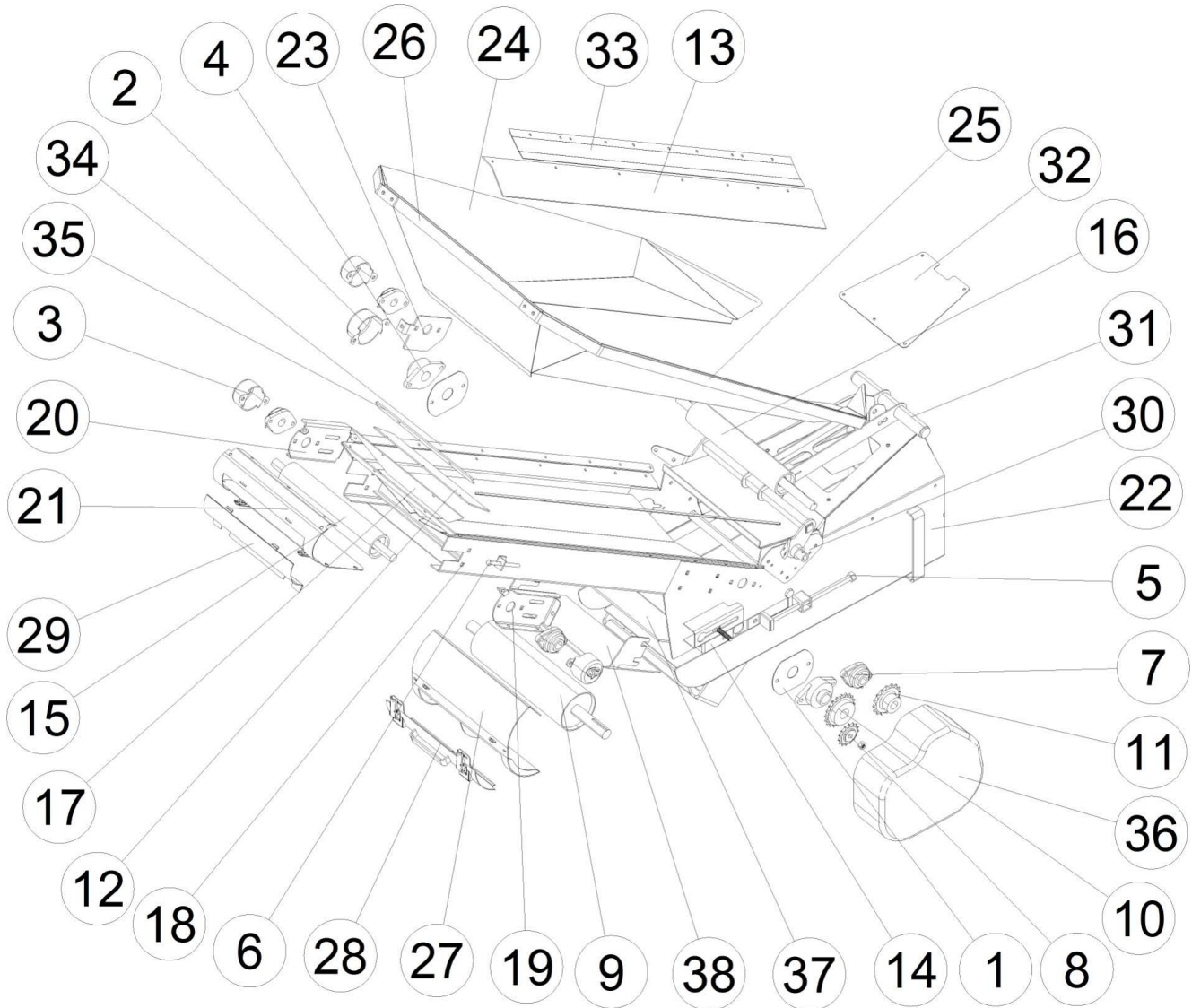

For 23 Serial Number 16188 and Higher

Conveyor - Continued

Lower End Group - 23 foot - Continued

Item	Part No.	Description	Qty
1	N60646	Bearing Plate - 20048-01	2
2	N58844	Cover - 1 1/4" Bearing - 23150-02	1
3	N58842	Cover - 1" Bearing - 23150-04	2
4	N49488	Bearing - Flange - 1 1/4" (J-Day T-62G) - 24112-01	2
5	N55874	Screw - Tensioning (5/8) - 24115-01	3
6	N62327	Tap Bolt - 3/8 x 5 Lg - 24208-01	3
7	N49486	Bearing - Flange - 1" - 24336-01	4
8	N49483	Sprocket, Idler - 50/15 - 24396-01	1
9	N56132	Drum Assembly - 5" - 24440-01	1
10	N56735	Sprocket - 50/25 - 24491-05	1
11	N56736	Sprocket - 50/13 - 24397-02	1
12	N49480	Tail Flap - Lower - 28351-01	1
13	N55892	Flap Hopper Side - 45432-05	2
14	N60649	Bracket Assembly - Lower Bearing - 46007-00-MR	2
15	N56133	Drum Assembly - 3" Idler - 47514-00	1
16	N56134	Drum Assembly - 3" Lagged - 47523-00	1
17	N49476	Flap Hopper - Back - 47640-01	1
18	81003-00-MR	Frame AS.	1
19	81005-00-MR	Bearing Slide	1
20	81006-00-MR	Bearing Slide	1
21	N62090	Rear Cover - Stainless - 81007-80 (for 23' SN 16188 and above)	1
22	81009-00-MR	Transition Assembly - Lower	1
23	81010-01-MR	Bearing Bracket	1
24	N55895	Canvas - Hopper W/2 Hole Side Rails - 81011-01 serial #16188 to 17394	1
	N60642	Canvas - Hopper W/3 Hole Side Rails - 81011-04 serial #17395 and Higher	1
25	N56091	Hopper Bar - Sides - 81095-00-MR	2
26	N64001	Hopper Strap - Back - 81012-02-MR	1
27	81015-00-MR	Cover - Rear	1
28	N55896	Door - Rear - 81016-00-MR	1
29	N55897	Rear Door - Inlet - 81017-00-MR	1
30	81018-00-MR	Handle Pivot	1
31	N64235	Hopper Handle - 81019-00-MR	1
32	81021-01-MR	Cover - Transition	1
33	81022-81-MR	Hold Down Flap	2
34	N64083	Strap Side - 81023-01-MR	2
35	N64084	Strap End - 81023-02-MR	1
36	81026-01	Guard Chain	1
37	N55889	Flow Guard - 81027-01	1
38	81028-01-MR	Flowguard Flap Support	1
		Items Not Shown	
	N60643	Hopper Handle - 3 hole mount - 23 ft - SERIAL #17395 + HIGHER	
	N56105	Belt-Crescent Cup - 16 x 112 Lg - 24121-92 (for 23' SN 16188 and above)	1
	N49469	Belt Splice Kit - 24387-16 (Kit can be used with either belt as it only includes lacing parts)	1
	N64090	Belt Splice Tool - 24387-01	
	N53224	Cleated Belt Splice Kit - Includes 24" cleated belt, splices, wire cable, crimp washers	
	24398-03	Link Connecting #50 Heavy	1
	24356-01	Key - 1" Shaft	2
	24492-03	Hitch Pin - 1/2 x 4 Lg	1
	N49477	Cleated Belt Seal Flap - Left Low - 46105-01	1
	N49478	Cleated Belt Seal Flap - Right Low - 46105-02	1
	N49476	Rear Hopper Belt Seal - 47640-01	1
	N55891	Flap - Flow Guard - 81029-01	1
	N60938	Collapsable Hopper Cover - Fits Collapsible Hopper serial #16188 to 17394	1
	N62290	Collapsable Hopper Cover Kit - Fits Collapsible Hopper serial #16188 to 17394	1

Maintenance

Conveyor - Continued

Lower End Group

25 foot Conveyor

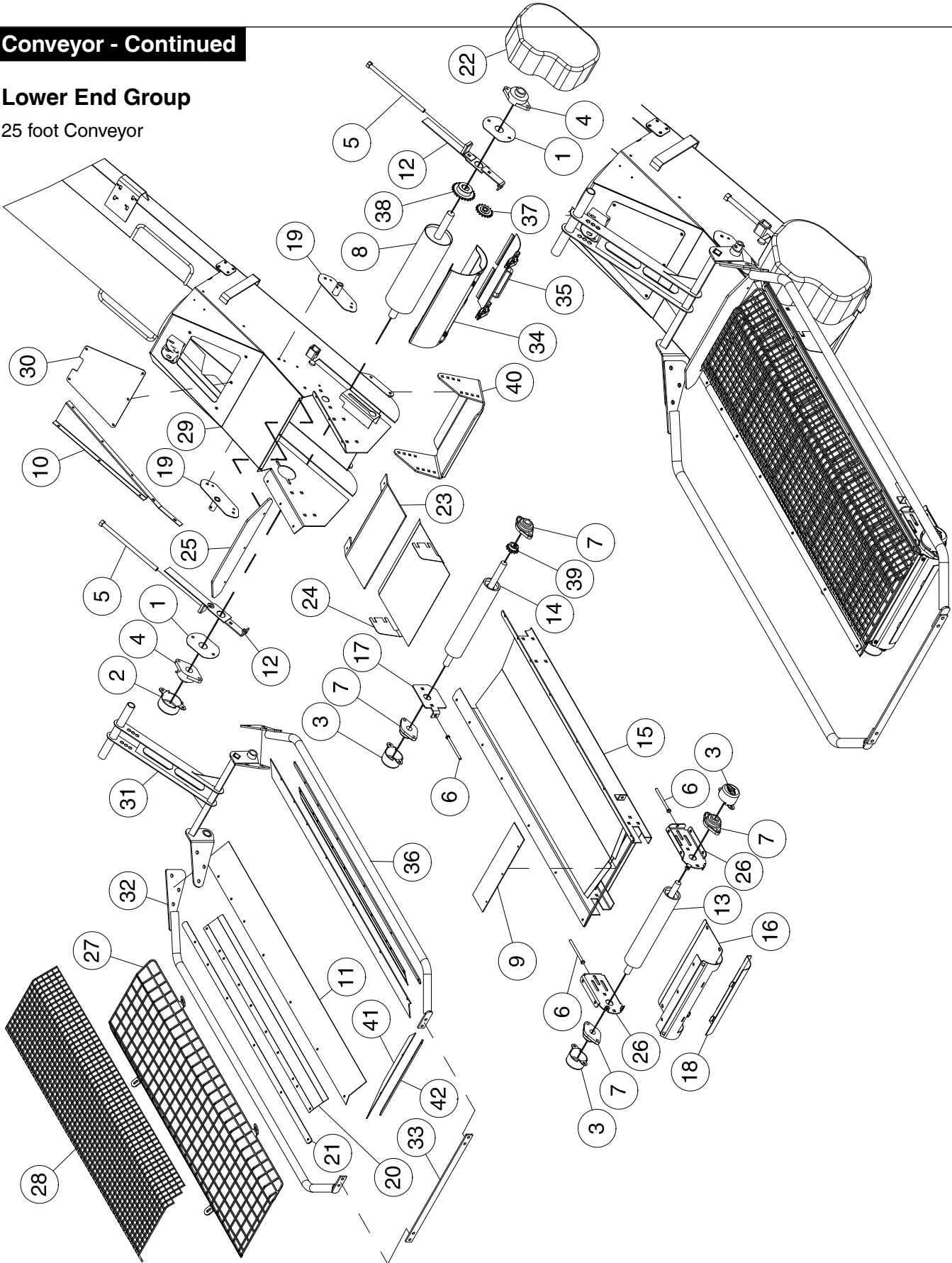

Conveyor - Continued

Lower End Group - 25 foot - Continued

Item	Part No.	Description	Qty
1	N60646	Bearing Plate - 20048-01	2
2	N58844	Cover - 1 1/4" Bearing - 23150-02	1
3	N58842	Cover - 1" Bearing - 23150-04	3
4	N49488	Bearing Flange - 24112-01	2
5	N55874	Tensioning Screw - 5/8 - 24115-01	2
6	N62327	Tap Bolt - 3/8 x 5 - 24208-01	3
7	N49586	Bearing Holder - 24336-01	4
8	N56132	Drum 5" - 1 1/4" Shaft Lagged - 24440-01	1
9	N49480	Lower Tail Flap - 28351-01	1
10	N60617	Flap Bracket - Left (Shown) - 45425-01-MR	1
	N60618	Flap Bracket - Right (Not Shown) - 45425-02-MR	1
11	N55892	Flap Hopper Side - 45432-05	2
12	N60649	Lower Braket Assembly - 46007-00-MR	2
13	N56133	Idler Roller Assembly - 47514-00	1
14	N56134	Drive Roller Assembly - 47523-00	1
15	81003-00-MR	Frame Assembly	1
16	N62090	Feed Belt Door Frame - 81007-80	1
17	81010-01-MR	Bearing Bracket	1
18	N55897	Rear Door Inlet - 81017-80	1
19	81018-00-MR	Handle Pivot	2
20	81022-81	Hold Down	2
21	N64083	Side Strap - 81023-01-MR	2
22	81026-01-MR	Chain Guard	1
23	N55889	Flowguard Flap - 81027-01	1
24	81028-01-MR	Flowguard Flap Support	1
25	N55891	Rubber Flap - 81029-01	1
26	81030-00-MR	Lower Bearing Bracket	2
27	N60615	Hopper Screen - 81034-00-MR	1
28	N60620	Hopper Screen Fine - 81063-01-MR	1
29	81083-00-MR	Lower Transition Assembly	1
30	81084-00-MR	Transition Cover	1
31	N69550	Hopper Handle - 81086-00-MR	1
32	N60645	Hopper Side Rail Right - 81087-00-MR	1
33	N64085	Back Hopper Strap - 81088-01-MR	1
34	81089-00	Rear Cover	1
35	81090-00	Rear Door	1
36	N60644	Hopper Side Rail Left - 81093-00-MR	1
37	N49483	Idler Sprocket - #50-15 - 24396-01	1
38	N56735	Sprocket - 50-25T - 24491-05	1
39	N56736	Sprocket - 50-13T - 24397-02	1
40	N58843	Tail Rest	1
41	N49476	Flap Hopper Back - 47640-01	1
42	N64084	End Strap - 81023-02-MR	1
		Items Not Shown	
	N65795	Canvas - Hopper W/3 Hole Side Rails - 81011-02	1
	N62290	Hopper Cover Kit	1
	N49477	Flap - 10" Left Side - 46105-01	1
	N49478	Flap - 10" Right Side - 46105-02	1
	24356-01	Key - 1/4"	2
	N56105	Belt Crescent Cup - 16" x 112" - 24121-92	1
	N49469	Belt Splice Kit - Lacing Parts Only - 24387-16	1
	N64090	Belt Splice Tool - 24387-01	
	N58827	Splice Pin 16" Belts - 24121-75	1
	24492-03	Hitch Pin	1
	24398-01	Heavy Roller Chain - #50	1
	24253-01	Hinge	1
	24254-01	Rubber Handled Draw Latch	1
	82024-01	Backer Hinge Plate	1

Maintenance

Conveyor - Continued

Upper End Group

23 foot Conveyor

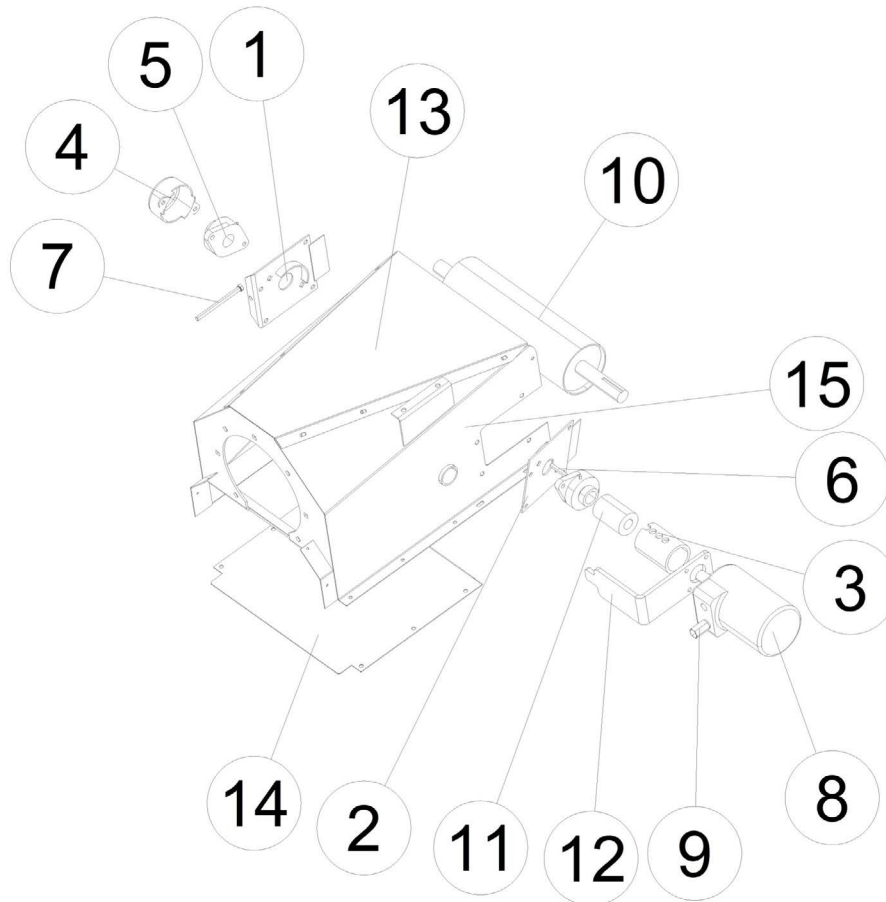

Item	Part No.	Description	Qty
1	N60801	Plate Assembly - Bearing - Left - 20012-00.....	1
2	N60802	Plate Assembly - Bearing - Right - 20013-00	1
3	N53682	Tube - Shaft Guard - 20077-03	1
4	N58844	Bearing Cover - 1 1/4" Bearing - 23150-02.....	1
5	N49488	Bearing - Flange - 1 1/4" - 24112-01	2
6	24177-01	Key - 1 1/4" Shaft.....	1
7	N62327	Tap Bolt - 3/8 x 5 - 24208-01	1
8	N58845	Hydraulic Motor - 7.7 cu. in. - 24495-CaseDrain (Seal Kit - N55718)	1
9	N53729	Check Valve - ORB - 24369-02	1
10	N56132	Drum Assembly - 5" - 24440-01	1
11	N53683	Coupler - 24473-03	1
12	45076-01	Motor Mount - Hydraulic.....	1
13	N60806	Cover - Top - 46014-01	1
14	N60616	Cover - Bottom - 46034-01	1
15	81014-00	Upper Housing	1

Conveyor - Continued

Upper End Group

25 foot Conveyor

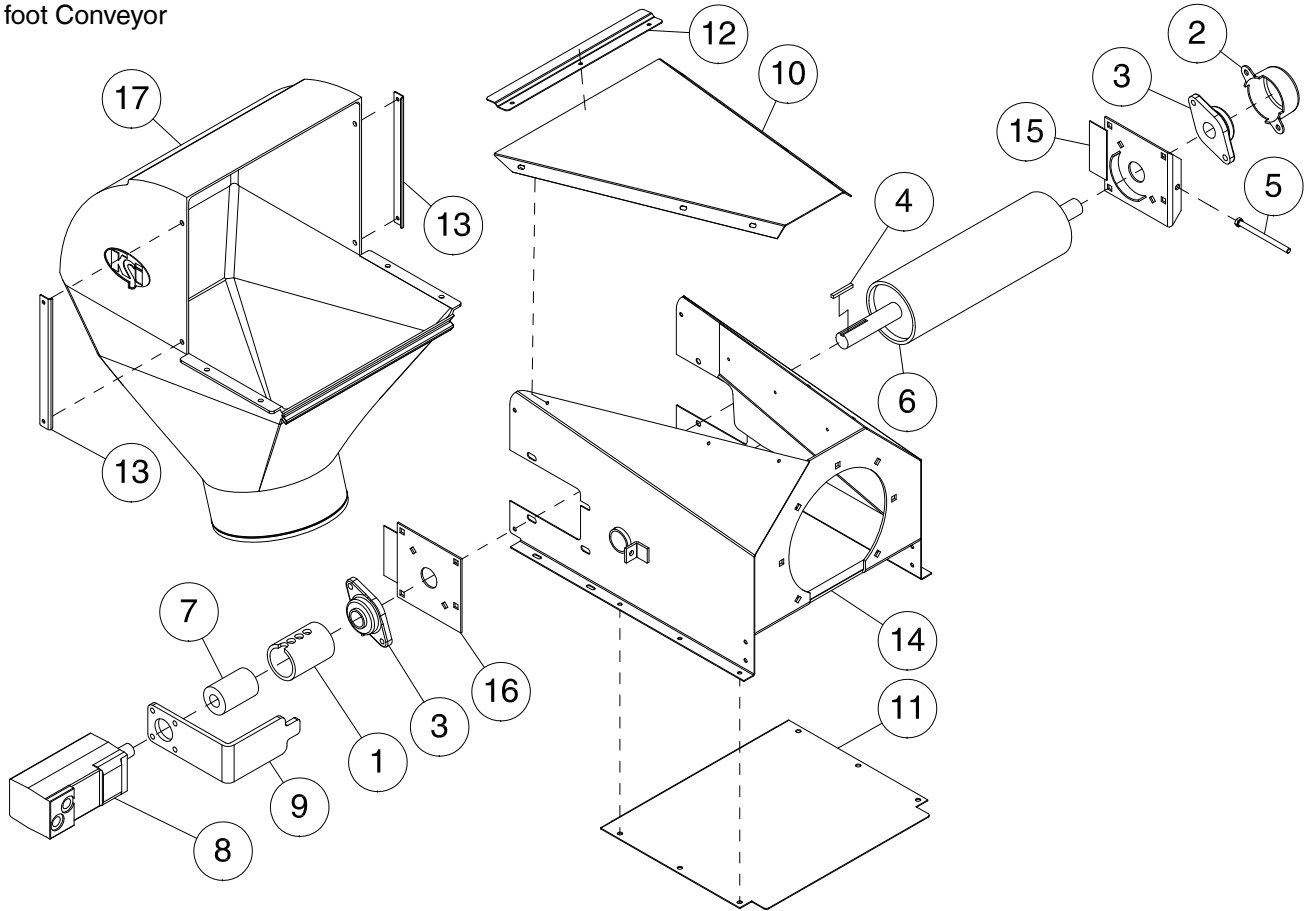

Item	Part No.	Description	Qty
1	N53682	Tube - Shaft Guard - 20077-03.....	1
2	N58844	Plastic Cover - 1-1/4" Bearing - 23150-02	1
3	N49488	Flange Bearing - 1-1/4" - 24112-01	2
4	24177-01	Key - 1 1/4 Shaft	1
5	N62327	Tap Bolt - 3/8 x 5 - 24208-01	1
6	N56132	Drum Assembly (5"), Lagged - 24440-01	1
7	N53683	Coupler - 24473-03.....	1
8	N58845	Hydraulic Motor - 7.7 cu. in. - 24495-CaseDrain (Seal Kit - N55718)	1
9	45076-01-MR	Motor Mount (Hyd).....	1
10	N60806	Top Cover Panel - 46014-01-MR.....	1
11	N60616	Top Transition Bottom Cover - 46034-01-MR	1
12	N56129	Hold Down Strap Top - 81024-01-MR	1
13	N56131	Hold Down Strap Side - 81024-02-MR.....	2
14	81085-00-MR	Head Assembly	1
15	82213-00-MR	Plate, Bearing, Left	1
16	82214-00-MR	Plate, Bearing, Right.....	1
17	N53679	Moulded Conveyor Spout - 10" - 85074-01	1
	N53729	Hydraulic Check Valve - SAE10 Thread - 24369-02 (Not Shown)	1
	24574-02	Hydraulic Plug - Oring (Not Shown).....	1

Maintenance

Brakes

Periodic Inspection should be made of the electrical connector, wiring, brake lines and hose for the entire brake system to insure there are no abraded or bare wires, damaged steel lines, or cracked and damaged hoses. During inspection assure there are no loose or “hanging” lines or wire that might drag or catch on objects/debris while being towed.

Fill Reservoir

There are two filler caps on the reservoir, either may be used for filling and checking fluid level as they both enter a common reservoir. Use caution when removing a filler cap to prevent the admission of dirt and/or contaminants into the fluid reservoir.

Check the fluid level in the reservoir. The fluid level must be maintained within 3/8 to 1/2 inch below the filler opening. If brake fluid is needed add only **NEW, CLEAN, DOT III BRAKE FLUID**.

Never reuse brake fluid that has been salvaged or removed from another system. Contaminated or dirty brake fluid may cause damage to the system resulting in system failure.

Bleeding the Brakes

It is essential to remove all air from the brakes and brake-lines prior to operation of the Air Cart. Operate unit with tractor brakes or manual override on Controller. Each Caliper has two (2) bleeder screws, each one should be bled until fluid is free of air bubbles. Starting with the right brake open bleeder screw #1 and allow it to remain open until seeing brake fluid free of air bubbles coming out of the bleeder screw. Close the bleeder screw and move to the second bleeder screw repeating process. Repeat process for left brake.

While performing the bleeding process monitor the fluid level in the reservoir so that more air is not pumped into the brake lines because of low fluid level.

To prevent spilling brake fluid on the ground one end of a length of plastic tubing should be placed over the end of the bleeder screw and the other end should be placed into a container so that the fluid flow can be monitored for bubbles.

Note: Final stage of brake bleeding must be performed with tractor running to achieve full voltage/amps at BrakeRite pump. Unit will not generate maximum pressure otherwise.



Important:

Use only DOT III brake fluid.

Maintain fluid level within 3/8 to 1/2 inch below the filler opening.

Use caution when removing the filler cap to prevent contaminants entering into the fluid reservoir.

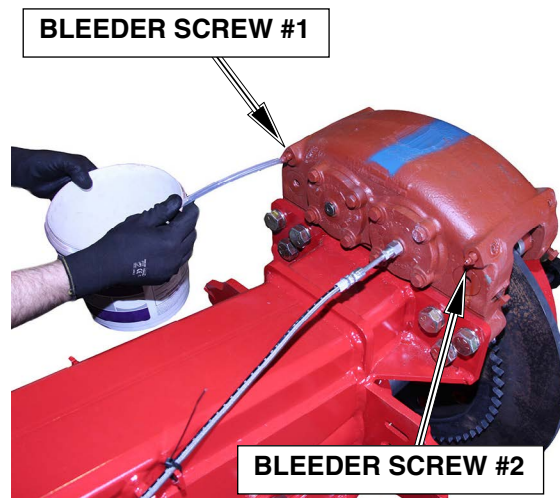

Brakes - Continued

Brake Pads

- Check brake pads for wear. If the thickness of the brake pad is 1/8" or less it is recommended to replace the brake pads.

To replace the brake pads use procedure below:

- Remove the wheels to gain adequate access to the calipers.
- Remove the bolt from each retaining pin.
- Slide the brake pad retaining pins out of the caliper and remove the brake pads.
- Install new brake pads and install retaining pins.
- Secure each retaining pins with bolt.

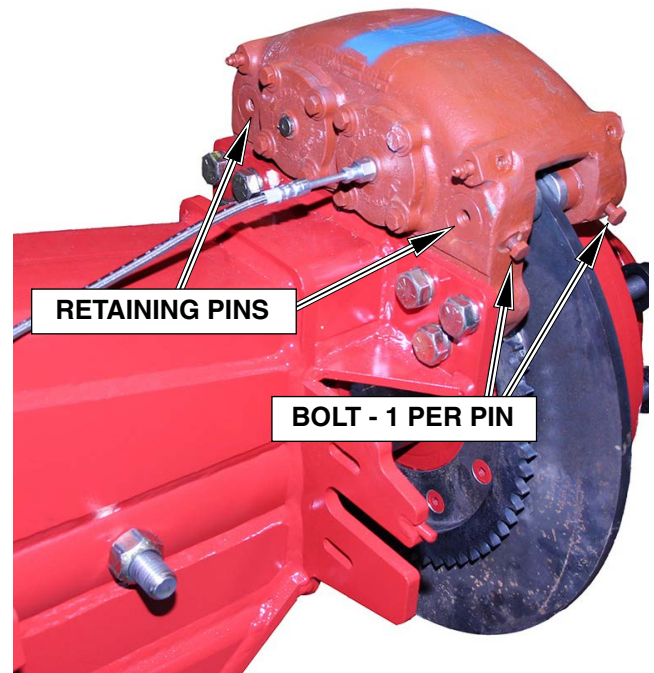

Caliper Pistons and Seal Replacement

- Remove the wheels to gain access to the calipers.
- Remove brake line and mounting bolts.
- Remove worn brake pads.
- Follow instructions in seal kit for piston removal and seal installation.
- Install new brake pads.
- Mount caliper to mounting plate and attach brake line.
- Bleed brakes.

Maintenance

Note

Section 7: Storage

Section Contents

Preparing for Storage	7-2
General	7-2
Metering Body Storage	7-3
Removing From Storage.....	7-4
General	7-4
Monitor	7-4
Auger.....	7-4
Conveyor	7-4
Brakes	7-4

Storage

Preparing for Storage

General

- To insure longer life and satisfactory operation, store the 9 Series Air Cart in a shed.
- If building storage is impossible, store away from areas of main activity on firm, dry ground.
- Clean machine thoroughly.
- Inspect all parts for wear or damage.
- Avoid delays - if parts are required, order at the end of the season.
- Lubricate grease fittings (Refer to Lubricating Section).
- Tighten all bolts to proper specifications (Refer to Bolt Torque Chart).
- To prevent corrosion and damage by rodents, clean the hopper boxes and metering systems thoroughly and wash with mild soapy water solution. Rinse with water and dry thoroughly (Refer to Metering Body Storage).
- A light coating of silicone lubricant or WD-40 or penetrating oil should be applied to all metal metering system components before storage.
- Avoid lubricant contact with seals.
- Avoid lubricant contact with grain and fertilizer hoses and tubes.
- Relieve tension on tank lids.
- Loosen clean-out doors.
- Remove all chains and store in clean oil.
- Relieve pressure from hydraulic system.
- Raise frame, block up and relieve weight from the tires.
- Cover tires with canvass to protect them from the elements when stored outside.
- Paint any surfaces that have become worn.



Warning

**Do not allow children to play
on or around the machine.**

Powder Paint - 2024

Part Number	Description
S73107	Red MORRIS Aerosol Can
	Silver MORRIS Aerosol Can
K65885	White MORRIS Aerosol Can

Enamel Paint - Prior to 2024

Part Number	Description
N53713	Red MORRIS Touch-Up Pen
N53714	Silver MORRIS Touch Up Pen
N53715	Red MORRIS Aerosol Can
N53716	Silver MORRIS Aerosol Can
N31087	Sky White MORRIS Aerosol Can

Preparing for Storage - Continued

Metering Body Storage

It is extremely important that the metering system is thoroughly cleaned before storing for any length of time.

The following procedure should be followed for both tanks:

- Empty tanks (Refer to Unloading Tanks).
- Open Inspection Door and rotate seed plate to fully open position.
- Open Pressure Chamber Covers and blow air around chamber to ensure it is free of debris.
- Brush out remaining material in the corners and on top of the back plate.
- Rotate meter shaft using Run-Rest box to empty meter wheel flutes.
- Run fan.
- Wash the interior of both tanks and metering system with soapy water. Wash the collector.
- Rinse with cold water and let the unit air dry.
- Coat metal parts with silicone lubricant or WD-40.

Note: Diesel fuel will harm seals.

- Set seed plate to correct position for product being metered.
- Install Pressure Chamber Covers ensuring that the seals are free from debris and leaks.
- Close inspection door and collector bottom ensuring that the seals are free from debris and leaks.
- Start the fan and operate for 5 minutes to dry out any remaining moisture in the system.
- Leave inspection doors loose to help prevent condensation building up inside the tank.
- Leave lid latches loose to help maintain resilience of the seals.

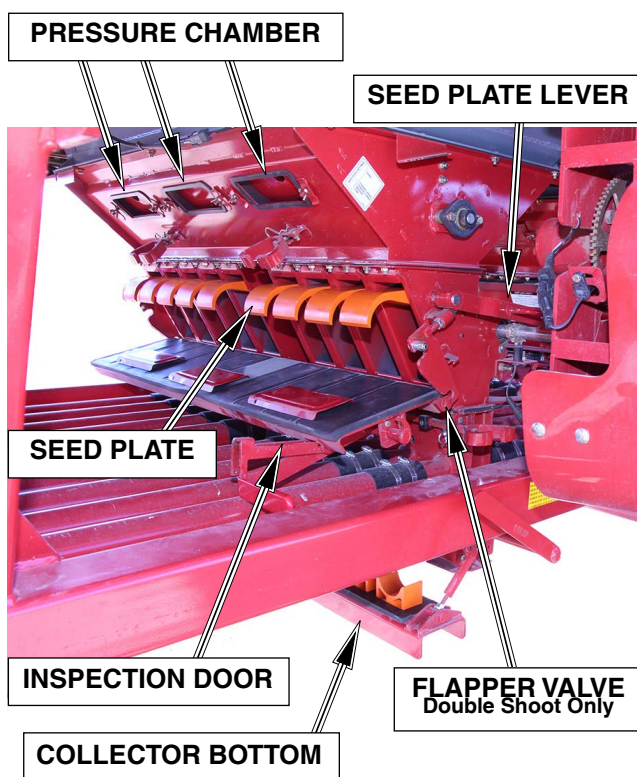

Important

At no time should corrosive fertilizer or similar materials be allowed to remain in the tank or metering body cavity.

Storage

Removing From Storage

General

- Review Operator's Manual.
- Check tire pressure (Refer to Tire Pressure List).
- Clean machine thoroughly.
- Tighten lid latches.
- Lubricate and install chains.
- Spray internal parts of the metering body with silicone lubricant or WD-40 or penetrating oil to loosen any corrosion buildup.
- Check for leaks (Refer to Maintenance Section).
- Lubricate grease fittings (Refer to Lubricating Section).
- Tighten all bolts to proper specifications (Refer to Bolt Torque Chart).

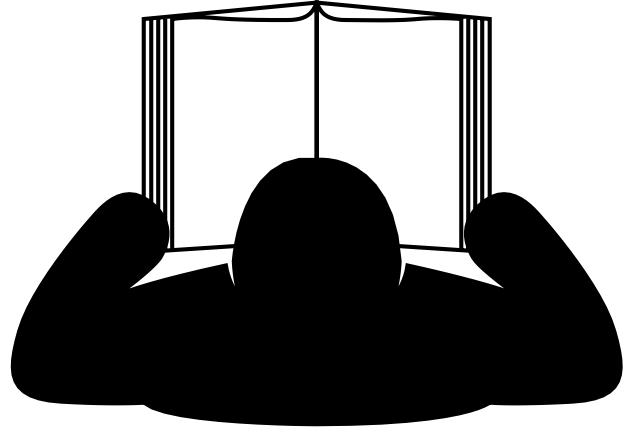

Monitor

Familiarize yourself with all monitor functions. Ensure all monitor “*settings*” are correctly set for the air cart/ seeding tool combination. Recognize and correct alarm conditions as indicated on the machine. See Monitor Section for more details.

Check all wire harness connections for corrosion and use a dielectric spray to clean. Inspect all sensors for proper gap. See Monitor Section for more details.

Auger

Inspect all augers used in handling the products for seeding. Run augers to clean out any debris inside auger so it does not get transferred to the tank.

Conveyor

Any conveyor that has sat idle for a season needs to go through a “break-in” period. See “Startup and Break-In” under the Operation Section.

Brakes

Check the fluid level in the reservoir. Verify the brake system is working properly. See Operation Section.

Section 8: Troubleshooting

Section Contents

General.....	8-2
Delivery hoses plugged.....	8-2
Hydraulic fan will not turn.....	8-2
Fan turning too slow.....	8-2
Material flowing thru system when unit is stationary and the fan running.....	8-2
Material not being divided in distribution head.....	8-2
Material not being metered out.....	8-3
Material not being accurately metered out of the metering body.....	8-4
Plugged seed boots.....	8-5
VRT System.....	8-6
Motors will not turn in Manual Mode (Controller OFF).....	8-6
Motors will not turn in Operation Mode (Controller ON).....	8-6
Motors turn continuously in Operation Mode.....	8-6
Motors turn continuously in Calibration Mode.....	8-6
Monitor.....	8-7
Monitor lights up but does not seem to work.....	8-7
No fan display.....	8-7
No ground speed display.....	8-7
No display, no back light.....	8-7
Bin indicates always empty.....	8-7
Bin indicates always full.....	8-7
Conveyor.....	8-8
The conveyor is vibrating.....	8-8
Capacity is too low.....	8-8
The conveyor plugs.....	8-8
Driveline shear bolt shears frequently.....	8-8
Cleated belt is slipping or loose.....	8-9
Cleated belt is rubbing side of housing or cleats are coming loose or wearing.....	8-9
Brakes.....	8-9

Troubleshooting

Problem	Cause	Correction
General		
Delivery hoses plugged	Insufficient air flow.	Clean fan impeller blades. Clean fan intake screen. Increase fan rpm.
	Hose sag.	Shorten hoses or add additional supports.
	Seed boots plugged with dirt.	Clean seed boots. See “ <i>Seed Boot Plugging</i> ” below.
	Hose obstruction.	Remove obstruction from hose.
	Air delivery hose partly off manifold.	Reinstall hose properly on manifold.
	Kinked hoses.	Straighten hoses and properly secure them to framework.
	Obstruction in divider head.	Remove access door and clear obstruction from appropriate outlets - be sure to use appropriate screens when filling.
	Exceeding machine’s delivery capabilities.	Reduce ground speed and speed up fan.
Hydraulic fan will not turn	Poorly mounted hoses.	Reroute hoses.
	Selector valve in wrong position.	Switch the selector to fan position.
	Hydraulic hoses not connected properly to tractor.	Reverse hydraulic hoses.
Fan turning too slow	Insufficient oil flow.	Perform flow test.
	Flow to hydraulic motor.	Increase flow control setting.
Material flowing thru system when unit is stationary and the fan running	Low hydraulic pressure.	Check hydraulic pressure minimum 2100 psi.
	Damaged metering wheel.	Replace metering wheel.
Material not being divided in distribution head	Incorrect Seed Plate Setting.	Adjust as required. See “ <i>Seed Plate Settings</i> ”.
	Head partially blocked.	Remove blockage and reinstall hose.
	Kinked hose running to shank.	Straighten or replace hose.

Troubleshooting

Problem	Cause	Correction
Material not being divided in distribution head	Head partially blocked.	Remove blockage and reinstall hose.
	Kinked hose running to shank.	Straighten or replace hose.
	Damaged distribution section on head.	Replace head with new one.
	Bent or damaged diffuser pipe.	Straighten or replace diffuser pipe.
	Secondary hose length.	See “Secondary Hose” in Operation Section.
	Tanks not pressurized.	Inspect lid seals. Clean pressurization hoses.
Material not being metered out	Main drive chain not installed.	Install drive chain properly on Drive Sprocket.
	Drive chain or chains broken.	Install new chain. Ensure connecting link is installed correctly. Curved part of spring clip should face the direction of chain travel.
	Massive air leak in tank, resulting in material being blown up out of the metering cup.	Repair the air leak. See “Air Leaks” in Maintenance Section. See “Tank Lid Adjustment” in Maintenance Section.
	Material caked up in tank.	Remove material and completely clean out the tank.
	Excessively wet material in tank.	Remove wet material and use reasonably dry material.
	Coupler bolt sheared.	Replace with Grade 8 bolt.

Troubleshooting

Problem	Cause	Correction
Material not being accurately metered out of the metering body	Air delivery hoses loose, cracked or pulled off.	Tighten the hoses, replace cracked hoses or install hoses pulled off their respective locations.
	Inlet screen to fan blocked off.	Clean off material that is blocking the fan screen.
	Incorrect Seed Plate Setting.	Adjust Seed Plate - See Operation Section.
	Seed Plate lock not adjusted correctly.	Adjust Seed Plate lock - See Operation Section.
	Material caked up above one or more of the metering cups.	Clean out caked up material.
	Excessively damp material in tank.	Use reasonably dry, fresh material only.
	Foreign obstruction in tank above metering wheels.	Remove obstruction, and always fill tanks through the screen.
	Caked up metering wheels on some or all of the metering cups.	Clean out the metering cups and wheels.
	Damaged metering wheels.	Replace damaged metering wheels.
	Metering wheels mismatched to secondary outlet.	Install correct wheels to head. 1 3/4" wide wheel for 7 outlet head. 2" wide wheel for 8 outlet head. 2 1/4" wide wheel for 9 outlet head. 2 1/2" wide wheel for 10 outlet head. Be sure appropriate spacers are also used.
	Collector Valves set incorrectly on Double Shoot machines.	See Operation Section.
	Air Leak in System.	Adjust lids and doors as necessary. Replace damaged seals. See Maintenance Section.
	Meterbody pressurization hose disconnected.	Reconnect hose to meterbody/plenum.

Troubleshooting

Problem	Cause	Correction
Plugged seed boots	Backing up with openers near or in the ground.	Lift machine all the way up before backing up.
	Turning very sharp with openers near or in the ground.	Lift machine all the way up when making sharp turns.
	Lowering machine without any forward motion.	Always have forward motion when lowering machine.
	Worn openers or sweeps.	Replace openers.
	Severely bent or damaged boots.	Straighten or replace as required.
	Excessively wet conditions.	Change openers, operate when drier.
	Opener Adjustment.	See " <i>Opener Adjustment</i> " in Operation Section.

Troubleshooting

Problem	Cause	Correction
VRT System		
Motors will not turn in Manual Mode (Controller OFF)	Selector valve (Fan/Auger).	Switch selector valve to fan position.
	Hydraulic oil flow.	Ensure hydraulic lever is properly engaged.
Motors will not turn in Operation Mode (Controller ON)	Selector valve.	Switch selector valve to fan position.
	Hydraulic oil flow.	Ensure hydraulic lever is properly engaged.
	VRT Sensor Gap.	Gap should be 0.030" (0.76 mm).
Motors turn continuously in Operation Mode	Shaft Motor Solenoids.	Zero Shaft Motors. See "Preparing VR System".
	VRT Sensor Gap.	Gap should be 0.030" (0.76 mm).
Motors turn continuously in Calibration Mode	VRT Sensor Gap.	Gap should be 0.030" (0.76 mm).

Troubleshooting

Problem	Cause	Correction
Monitor		
Monitor lights up but does not seem to work	Faulty monitor.	Replace monitor.
	Completely disconnected harness.	Connect harness.
No fan display	Incorrect gap between sensor and target.	Gap should be 0.030" (0.76 mm).
	Faulty sensor.	Replace sensor.
	Broken or shorted wire.	Replace or repair harness.
No ground speed display	Sensor to magnet gap too large.	Gap should be 0.030" (0.76 mm).
	Faulty sensor.	Replace sensor.
	Broken or shorted wire.	Replace or repair harness.
No display, no back light	Switched off.	Switch unit on.
	Poor power connections at the battery.	Ensure good connections. Replace monitor.
	Battery below 10.8 volts.	Check battery voltage.
	Temperature below -10C or above +40C.	Operate between -10C and +40C.
Bin indicates always empty	Broken wire.	Repair wire.
	Faulty sensor.	Replace sensor.
	Wires not hooked to sensor.	Hook up correctly.
Bin indicates always full	Blocked light beam on photoelectric sensor.	Remove object blocking the beam.
	Wire shorted to ground.	Repair or replace wire.
	Faulty sensor.	Replace Sensor.

Troubleshooting

Problem	Cause	Correction
Conveyor		
The conveyor is vibrating	Damage can occur to the belting, causing a noise. Damage usually is caused from foreign material being run through the conveyor.	It may be necessary to remove the belting for inspection.
	The belt is not tracking in the center of the conveyor.	Track the belt.
Capacity is too low	There may not be enough grain reaching the conveyor.	Make sure the intake has not bridged over, restricting flow. The belt needs to be covered to achieve maximum capacity.
	Conveyor belt is moving too slow.	Check the belt speed. Low capacity will result from speeds slower than recommended. Belt needs tightening.
The conveyor plugs	The conveyor may be “jamming” because too much grain is reaching the conveyor.	Decrease the amount of grain the conveyor is gathering.
	The grain may be wet.	If wet grain or other hard to move materials is being conveyed, reduce the amount of grain being fed into hopper.
	The conveyor may be jammed with foreign material.	Remove any foreign material in the conveyor.
	The discharge end may be plugged.	Unplug any plugs at the discharge end of the conveyor.
	Pulley has spun out and burned the belt in two.	Cut and resplice the belt, An additional piece of belting may be required. Tighten and retrack the belt.
Driveline shear bolt shears frequently.	Grain may be flowing too quickly into the hopper.	Reduce the flow rate of grain into hopper.
	The discharge of grain from the conveyor may be restricted.	Inspect conveyor intake and discharge for damage.

Troubleshooting

Problem	Cause	Correction
Cleated belt is slipping or loose.	Belt tension too low.	Tension belt to 23 ft. lbs. on the adjustment bolts. Tension hopper belt to 80 in. lbs. or until center of the belt rises off the support pan underneath.
	Belt is extremely dirty.	Clean traction side of belt.
Cleated belt is rubbing side of housing or cleats are coming loose or wearing.	Belt misaligned.	Align belt so its tracks center of idle and drive rollers. Tighten the side of the belt that is tracked off the roller.

Brakes

Indicator on "In Cab Controller" Shows no connection between towed and towing-vehicle.		Inspect plug and wiring for open circuit. Consult applicable wiring diagram to assure proper wiring connections.
Poor response time		Check and add brake fluid as required (figure 5.4.2A-pg.22) Bleed brake lines and devices Check input for adequate "charge" (12 VDC)
Inadequate or excessive Cart braking.		Adjust "gain" control on In-Cab Controller.
BrakeRite unit runs but does not build pressure.		Assure proper brake fluid level, add fluid and bleed the system as required.
BrakeRite unit does not run when the Tractor brake pedal is depressed		Verify and connect wire connections in the entire electrical circuit.
BrakeRite unit does not run when the in-cab manual override is activated.		Verify and connect wire connections in the entire electrical circuit.

Experience has shown that virtually all problems with BrakeRite units are the result of INCORRECT or FAILED WIRING. If problems arise consult the wiring diagram and inspect all wiring and terminations.

Troubleshooting

Notes



www.morrisequipment.ca

1891 Albert Street North,
Regina, Saskatchewan
S4R 8R7 Canada
Phone: 306-933-8585
Fax: 306-933-8626

It is the policy of Morris Equipment Ltd. to improve its products whenever it is possible to do so. Morris Equipment reserves the right to make changes or add improvements at any time without incurring any obligation to make such changes on machines sold previously.