

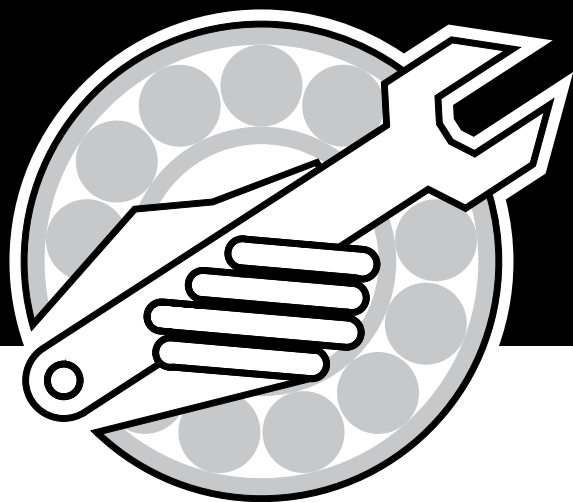

Parts Manual



C2 Contour Air Drill

IMPORTANT:

ALL ITEMS ARE IDENTIFIED WITH A PART NUMBER. Some of the smaller parts such as bolts, nuts, washers, etc. are not all shown, however, the quantity used are listed in the text for that section which they fit into. That particular quantity is always the quantity required for one complete assembly.

Smaller parts, which are welded together to construct a larger part, are not to be ordered as individual pieces, unless they have a part number to identify them.

Contact your nearest dealer for genuine repair parts. Dealers carry ample stock and are backed by the manufacturer and regional associations.

Powder Paint Introduced:

C2 Contours – All 2022 and newer.

MORRIS PAINT

Spray Cans:

Part Number	Description
S73107.....	Red MORRIS Powder Touch-Up Aerosol Can
W-4647	Red MORRIS Spray Can
N31087	Sky White MORRIS Spray Can

Litre Cans:

Part Number	Description
Z-10.....	Red MORRIS Paint/Litre

Manuals

Part Number	Description
S50150.....	Operator's Manual
S50153.....	25-31 Assembly Manual
S50151.....	41-90 Assembly Manual

Table of Contents

Section 1:

Frames & Hitching	1-1
Hitch - 41 Ft and 51 Ft - Prior to 2015	1-2
Hitch - 41 Ft to 71 Ft - 2015 to Present.....	1-4
Hitch - 61 Ft to 90 Ft - Prior to 2015	1-6
Hitch - 80 Ft to 90 Ft - 2015 to Present.....	1-8
Hitch - 25 & 31Ft Contour	1-10
Main Frame Front Axle Castor - 41 Ft to 90 Ft	1-11
Main Frame - 25 & 31Ft Contour.....	1-12
Main Depth Beams - 41 Ft to 90 Ft	1-14
Main Frame & Depth Beams - 41 Ft to 71 Ft	1-15
Main Frame & Depth Beams - 80 Ft to 90 Ft.....	1-16
Main Frame Front and Rear Hitch Beam - 80 Ft to 90 Ft	1-18
Front and Rear Hitch Beam - 41 Ft and 51 Ft - Prior to September 2012	1-20
Front and Rear Hitch Beam - 41 Ft to 71 Ft	1-21
Wing Lift, Wing Frame & Truss - 25 & 31 Ft	1-22
Wing Lift Lock - 25 & 31 Ft - Prior to 2017.....	1-23
Wing Lift Lock - 25 & 31 Ft - 2017	1-24
Wing Lift Lock - 25 & 31 Ft - 2018 to present	1-25
Wing Frame Depth Beams - 25 & 31 Ft	1-26
Wing Lift Truss - 41 Ft to 51 Ft.....	1-28
Wing Lift Truss - 61 Ft & 71 Ft.....	1-29
Wing Frame and Truss - 41 Ft to 51 Ft.....	1-30
Wing Frame Depth Beam - 41 Ft to 51 Ft	1-31
51 Ft Flip Wing.....	1-32
Wing Lift - 41 Ft to 51 Ft.....	1-34
Inner Wing Frame and Truss - 5 Frame.....	1-35
Inner Wing Frame - 61 Ft & 71 Ft	1-36
Inner Wing Frame - 80, 86 & 90 Ft.....	1-38
Outer Wing - 61 Ft.....	1-40
Outer Wing - 71 Ft.....	1-42
Outer Wing - 80, 86 & 90 Ft	1-44
Flip Wing - 80 & 86 Ft - Prior to December 2013.....	1-46
Flip Wing - 80 & 86 Ft - December 2013 to 2015.....	1-48
Flip Wing - 80 & 86 Foot - 2016 to Present.....	1-50
Flip Wing - 90 Ft - Prior to 2016.....	1-52
Flip Wing - 90 Ft - 2016 to Present	1-54
Wing Lift - 5 Frame	1-56
Lift Kit - 41 Ft to 71 Ft.....	1-58

Section 2:

Wheels	2-1
Main Dual Wheels	2-2
Front Axle Castor - 41 Ft to 90 Ft - 2018 to Present	2-2
Front Axle Castor - 41 Ft to 90 Ft - Prior to 2018.....	2-3
Rear Axles - 41 Ft to 90 Ft - 2018 to Present	2-4
Rear Axles - 41 Ft to 90 Ft - Prior to 2018.....	2-5
Main Single Wheels	2-6
Front Axle Castor - 25 and 31 Ft	2-6
Rear Axle - 25 and 31 Ft.....	2-7
Wing Dual Wheels.....	2-8
Front Axle Castor - 41 Ft to 90 Ft - 2018 to Present	2-8
Front Axle Castor - 41 Ft to 90 Ft - Prior to 2018.....	2-9
Rear Axle - 80 to 90 Ft - 2018 to Present	2-10
Rear Axle - 80 to 90 Ft - Prior to 2018.....	2-11
Wing Single Wheels	2-12

Table of Contents

Front Axle Castor - 25 Ft and 31 Ft.....	2-12
Rear Axle - 25 Ft to 71 Ft.....	2-13

Section 3:

Opener.....	3-1
Opener Assembly.....	3-2
Prior to 2020.....	3-2
2020 to 2021.....	3-4
Cast - 2022 to Present.....	3-6
Body Assembly.....	3-8
Prior to 2016.....	3-8
2016 to 2019.....	3-10
2020 to 2021.....	3-12
Cast - 2022 to Present.....	3-14
Packer Arm Assembly.....	3-16
Prior to 2020.....	3-16
Adjustable - Prior to 2020.....	3-17
Welded - 2020 to 2021.....	3-18
Cast - 2022 to Present.....	3-19
Packer Wheel Assemblies.....	3-20
Seed Boot.....	3-21
Injected Polymer Pair Row Kit.....	3-21
Injected Polymer Left Sideband Kit.....	3-22
Injected Polymer Right Side Band Kit.....	3-23
Single Shoot.....	3-24
Single Shoot 3" Spreader.....	3-25
Double Shoot - Paired Row.....	3-26
Double Shoot - High Pressure NH3 Kit.....	3-27
Double Shoot - Side Band - Left.....	3-28
Double Shoot - Side Band Boot - Right.....	3-29
Soil Levelers.....	3-30

Section 4:

Hydraulics.....	4-1
Wing Lift Hydraulics.....	4-2
25 & 31 Ft Model - Prior to 2017.....	4-2
25 & 31 Ft Model - 2017 to Present.....	4-4
41 Ft Model - Prior to September 2012.....	4-6
41 Ft Model - September 2012 to Present.....	4-8
51 Ft, 61 Ft and 71 Ft Models - Prior to September 2012.....	4-10
51 Ft, 61 Ft and 71 Ft Models - September 2012 to Present.....	4-12
80 Ft and 86 Ft Models - Prior to September 2013.....	4-14
80 Ft, 86 Ft and 90 Ft - September 2013 to Present.....	4-16
Wing Valve - 80 Ft, 86 Ft and 90 Ft.....	4-18
Accumulator and Hitch Hydraulics.....	4-20
25 & 31 Ft - Prior to 2016.....	4-20
25 & 31 Ft - 2016 to Present.....	4-22
41 to 86 Ft - Prior to September 2012.....	4-24
41 to 90 Ft - September 2012 to 2015.....	4-26
41 to 90 Ft - 2016 to Present.....	4-28
41 to 90 Ft - High Speed.....	4-30
Active Hydraulic Kit - Optional.....	4-32
Case Drain Tow Behind Carts - 2016 to Present.....	4-34
Opener Hydraulics.....	4-36
10 inch Spacing - 25 & 31 Ft Model - Prior to 2020.....	4-36
10 inch Spacing - 25 & 31 Ft Model - 2020 to Present.....	4-38

Table of Contents

10 inch Spacing - 41 Ft to 71 Ft	4-40
12 inch Spacing - 25 & 31 Ft Model - Prior to 2020	4-42
12 inch Spacing - 25 & 31 Ft Model - 2020 to Present.....	4-44
12 inch Spacing - 41 Ft to 71 Ft.....	4-46
12 inch Spacing - 80 Ft, 86 Ft and 90 Ft - Prior to 2020	4-48
12 inch Spacing - 80 Ft - 2020 to Present.....	4-50
12 inch Spacing - 90 Ft - 2020 to Present.....	4-52
12 inch Spacing - 41 Ft to 90 Ft - High Speed.....	4-54
Tow Between Air Cart - 7000 Series - Prior to 2016	4-56
Tow Between Air Cart - 8XL Series - Prior to 2016	4-57
Pressure Control.....	4-58
Digital Gauge - Standard Passive System	4-58
JEM Pressure Control System - for Active Hydraulic Option	4-59
9 Series Apollo - for Active Hydraulic Option.....	4-60
10 Series Apollo - for Active Hydraulic Option.....	4-62
Section 5:	
Cylinders and Valves.....	5-1
Wing Lift	5-2
Opener Cylinder	5-8
Opener Valve Block - Standard	5-9
Opener Valve Block - High Speed.....	5-10
Opener Valve Block - Active Hydraulics.....	5-11
Wing Lift Valve Block	5-12
Section 6:	
Distribution - 8XL Series Carts	6-1
Single Shoot Tow Behind - 25 Ft and 31 Ft.....	6-2
Single Shoot Tow Behind - 41 to 51 ft.....	6-4
Single Shoot Tow Behind - 61 to 86 ft.....	6-6
Single Shoot Tow Between - 25 Ft and 31 Ft	6-8
Single Shoot Tow Between - 41 to 51 ft.....	6-10
Single Shoot Tow Between - 61 to 86 ft.....	6-12
Dual Shoot Tow Behind - 25 Ft and 31 Ft.....	6-14
Dual Shoot Tow Behind - 41 to 51 ft	6-16
Dual Shoot Tow Behind - 61 to 86 ft	6-18
Dual Shoot Tow Between - 25 Ft and 31 Ft.....	6-20
Dual Shoot Tow Between - 41 to 51 ft.....	6-22
Dual Shoot Tow Between - 61 to 86 ft.....	6-24
Section 7:	
Distribution - 9 Series Carts	7-1
Quick Coupler	7-2
3 Outlet	7-2
5 Outlet	7-3
Single Shoot Tow Behind - 25 Ft and 31 Ft.....	7-4
Single Shoot Tow Behind - 41 to 51 ft.....	7-6
Single Shoot Tow Behind - 61 to 90 ft.....	7-8
Single Shoot Tow Between - 25 Ft and 31 Ft	7-10
Single Shoot Tow Between - 41 to 51 ft.....	7-12
Single Shoot Tow Between - 61 to 90 ft.....	7-14
Dual Shoot Tow Behind - 25 Ft and 31 Ft.....	7-16
Dual Shoot Tow Behind - 41 to 51 ft	7-18
Dual Shoot Tow Behind - 61 to 90 ft	7-20
Dual Shoot Tow Behind - 80 ft - 2021	7-22
Dual Shoot Tow Behind - 90 ft - 2018.....	7-24
Dual Shoot Tow Between - 25 Ft and 31 Ft.....	7-28

Table of Contents

Dual Shoot Tow Between - 41 to 51 ft.....	7-30
Dual Shoot Tow Between - 61 to 90 ft.....	7-32
Broadcast - Mounting Brackets	7-34
Stainless Head Conversion Kits	7-36
Chart	7-36
Divider Head Mounting Stands	7-37
Divider Head Assembly.....	7-39
Section 8:	
Options.....	8-1
Weight Kit.....	8-2
Rear Tow Hitch	8-3
Hitch Truss Kit - 61 and 71 Foot.....	8-4
Wing Lift Brace Kit - 81, 86 & 90 Foot	8-6
Remote Clutch Switch - Prior to September 2012	8-8
Remote Clutch Switch - September 2012 to 2014	8-9
Remote Clutch Switch - September 2014 to Present.....	8-10
Section 9:	
Optional 4th Row Kits	9-1
4 th Row - Wing Frame - 41 ft to 71 ft	9-2
4 th Row - OuterWing - 61 ft and 71 ft	9-3
4 th Row - 80 ft	9-4
4 th Row - 90 ft	9-6
4 th Row - Hydraulics	9-8
Section 10:	
Lighting and Safety Signs	10-1
Lighting	10-2
Safety Signs	10-6
Index	i

Section 1: Frames & Hitching

Section Contents

Hitch - 41 Ft and 51 Ft - Prior to 2015	1-2
Hitch - 41 Ft to 71 Ft - 2015 to Present.....	1-4
Hitch - 61 Ft to 90 Ft - Prior to 2015	1-6
Hitch - 80 Ft to 90 Ft - 2015 to Present.....	1-8
Hitch - 25 & 31Ft Contour	1-10
Main Frame Front Axle Castor - 41 Ft to 90 Ft	1-11
Main Frame - 25 & 31Ft Contour.....	1-12
Main Depth Beams - 41 Ft to 90 Ft	1-14
Main Frame & Depth Beams - 41 Ft to 71 Ft	1-15
Main Frame & Depth Beams - 80 Ft to 90 Ft.....	1-16
Main Frame Front and Rear Hitch Beam - 80 Ft to 90 Ft	1-18
Front and Rear Hitch Beam - 41 Ft and 51 Ft - Prior to September 2012	1-20
Front and Rear Hitch Beam - 41 Ft to 71 Ft.....	1-21
Wing Lift, Wing Frame & Truss - 25 & 31 Ft	1-22
Wing Lift Lock - 25 & 31 Ft - Prior to 2017.....	1-23
Wing Lift Lock - 25 & 31 Ft - 2017	1-24
Wing Lift Lock - 25 & 31 Ft - 2018 to present	1-25
Wing Frame Depth Beams - 25 & 31 Ft	1-26
Wing Lift Truss - 41 Ft to 51 Ft.....	1-28
Wing Lift Truss - 61 Ft & 71 Ft	1-29
Wing Frame and Truss - 41 Ft to 51 Ft.....	1-30
Wing Frame Depth Beam - 41 Ft to 51 Ft	1-31
51 Ft Flip Wing	1-32
Wing Lift - 41 Ft to 51 Ft.....	1-34
Inner Wing Frame and Truss - 5 Frame	1-35
Inner Wing Frame - 61 Ft & 71 Ft	1-36
Inner Wing Frame - 80, 86 & 90 Ft.....	1-38
Outer Wing - 61 Ft.....	1-40
Outer Wing - 71 Ft.....	1-42
Outer Wing - 80, 86 & 90 Ft	1-44
Flip Wing - 80 & 86 Ft - Prior to December 2013.....	1-46
Flip Wing - 80 & 86 Ft - December 2013 to 2015.....	1-48
Flip Wing - 80 & 86 Foot - 2016 to Present.....	1-50
Flip Wing - 90 Ft - Prior to 2016.....	1-52
Flip Wing - 90 Ft - 2016 to Present	1-54
Wing Lift - 5 Frame	1-56
Lift Kit - 41 Ft to 71 Ft.....	1-58

Frames & Hitching Hitch - 41 Ft and 51 Ft - Prior to 2015

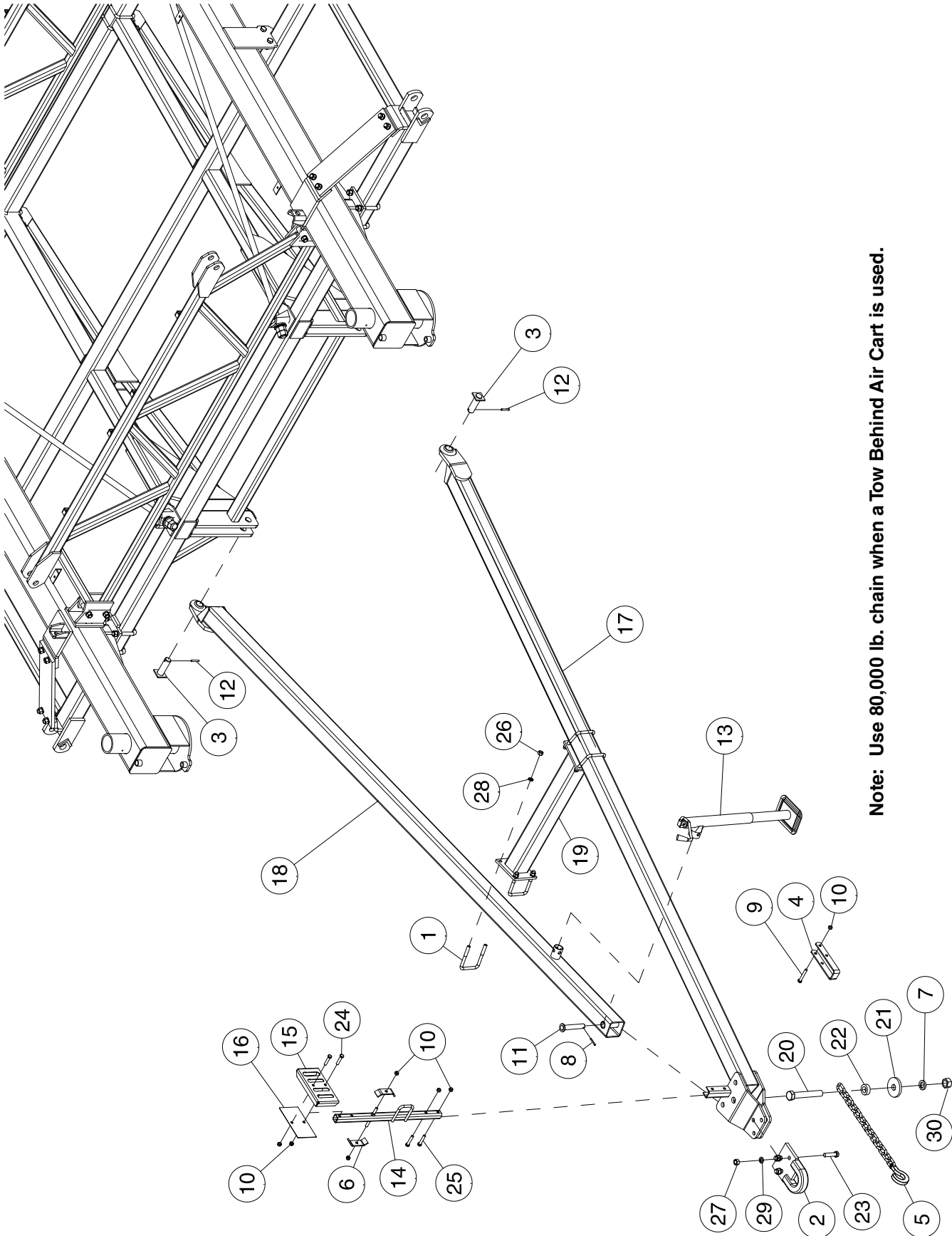

Note: Use 80,000 lb. chain when a Tow Behind Air Cart is used.

Hitch - 41 Ft and 51 Ft - Prior to 2015

Item	Part No.	Description	Qty
1	C-219	U-Bolt - 5/8 x 4 x 5 9/16	4
2	C-4438	Clevis - CAT 4	1
	S50205	Clevis - CAT 5 (2 3/4 Diameter Draw Pin)	
3	C18531	Pin - 1 3/8 Dia x 3 5/8 UL.....	2
4	C18758	Safty Chain Support.....	1
5	C18761	Safety Chain - 40,000 Lb	1
	N44710	Safety Chain - 80,000 Lb	
6	C26321	Hose Holder Clamp.....	2
7	C39432	Lockwasher - 1 1/4.....	1
8	D-5244	Spirol Pin - 1/4 x 2 Lg.....	1
9	D-5519	Hex Bolt - 1/2 x 3 1/4 Lg.....	1
10	F-3405	Locknut - 1/2 Unitorque.....	7
11	F-3645	Pin - 1 Dia x 5-1/4 UL.....	1
12	J12281	Spiral Pin - 5/16 x 2 Lg.....	2
13	S39391	Top Wind Jack - 2000 Lb.	1
14	S39665	Hose Holder Stand.....	1
15	S39666	Hydraulic Hose Holder Plate - 4 Slot.....	1
16	S39669	Back Plate - 4 Slot	1
17	S42942	Left Hitch Pole - 3 Frame.....	1
18	S42943	Right Hitch Pole - 3 Frame	1
19	S42944	Hitch Cross Brace - 35 1/16 Lg - 41 ft, 47 ft and 51 ft	1
20	S44715	Hex Bolt - 1 1/4 x 8 Lg.....	1
21	S44716	Retaining Washer - 1 5/16 ID x 4 1/4 OD x 1/2 Thick	1
22	S44717	Chain Link Spacer - 1 5/16 ID x 2 1/4 OD x 3/4 Thick - Required for 80,000 lb Chain.....	1
23	W-63	Hex Bolt - 3/4 x 3 Lg.....	3
24	W-489	Hex Bolt - 1/2 x 2 1/4 Lg.....	2
25	W-490	Hex Bolt - 1/2 x 2 1/2 Lg.....	2
26	W-517	Hex Nut - 5/8.....	8
27	W-518	Hex Nut - 3/4.....	3
28	W-526	Lockwasher - 5/8.....	8
29	W-527	Lockwasher - 3/4.....	3
30	P61D20	Hex Nut - 1 1/4.....	1

Prior to 2015 production year
 41 Prior to serial # C241142083
 51 Prior to serial # C251142130

Frames & Hitching
Hitch - 41 Ft to 71 Ft - 2015 to Present

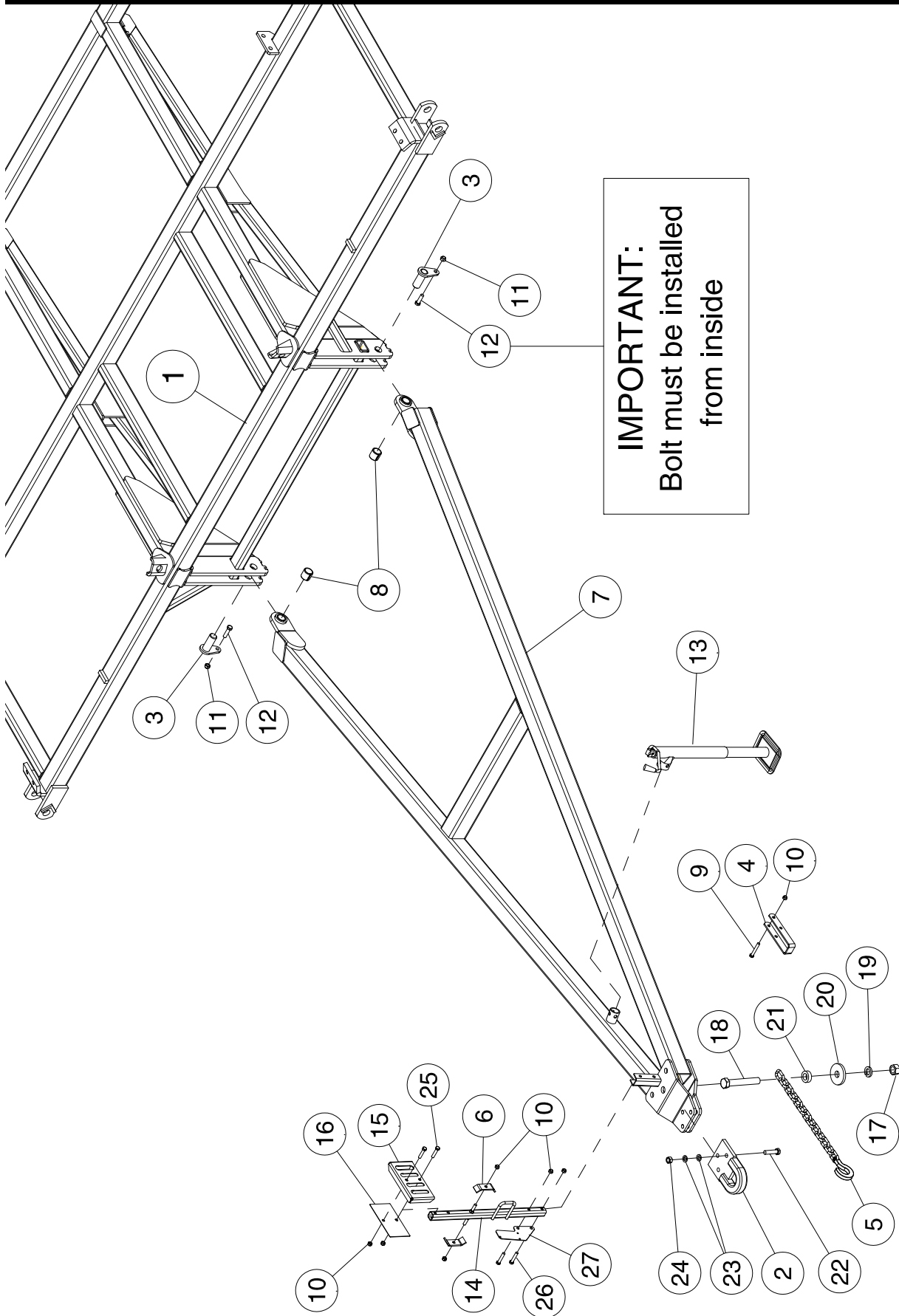

Note: Use 80,000 lb. chain when a Tow Behind Air Cart is used.

Hitch - 41 Ft to 71 Ft - 2015 to Present

Item	Part No.	Description	Qty
1	S55913	Main Frame - 16 FT - C2	1
2	C-4438	Clevis - CAT 4	1
	S50205	Clevis - CAT 5 (2 3/4 Diameter Draw Pin)	
3	S55909	Pin - 1 1/2 Dia x 3 11/16 UL	2
4	C18758	Safty Chain Support	1
5	C18761	Safety Chain - 40,000 Lb	1
	N44710	Safety Chain - 80,000 Lb	
6	C26321	Hose Holder Clamp.....	2
7	S55935	Hitch - 3 Frame - 41 and 51 (Includes Item 8)	1
	S55900	Hitch - 5 Frame - 61 and 71 (Includes Item 8)	1
8	S55309	Spring Bushing - 1 1/2 ID x 1 7/8 OD x 1 3/4 Lg	2
9	D-5519	Hex Bolt - 1/2 x 3 1/4 Lg.....	1
10	F-3405	Locknut - 1/2 Unitorque.....	7
11	S-1197	Locknut - 5/8 Unitorque	2
12	W-499	Hex Bolt - 5/8 x 2 Lg	2
13	S39391	Top Wind Jack - 2000 Lb.	1
14	S39665	Hose Holder Stand.....	1
15	S39666	Hydraulic Hose Holder Plate - 4 Slot - Single Fan.....	1
	S62722	Hydraulic Hose Holder Plate - 5 Slot - Dual Fan	
16	S39669	Back Plate - 4 Slot - Single Fan	1
	S62723	Back Plate - 5 Slot - Dual Fan	
17	P61D20	Hex Nut - 1 1/4.....	1
18	S44715	Hex Bolt - 1 1/4 x 8 Lg.....	1
19	C39432	Lockwasher - 1 1/4.....	1
20	S44716	Retaining Washer - 1 5/16 ID x 4 1/4 OD x 1/2 Thick	1
21	S44717	Chain Link Spacer - 1 5/16 ID x 2 1/4 OD x 3/4 Thick - Required for 80,000 lb Chain.....	1
22	11576	Hex Bolt - 3/4 x 3 1/2 Lg Grade 8	3
23	W-476	Flat Washer - 13/16 ID x 1 7/16 OD x 11GA	6
24	D-5273	Lock Nut - 3/4.....	3
25	W-489	Hex Bolt - 1/2 x 2 1/4 Lg.....	2
26	W-490	Hex Bolt - 1/2 x 2 1/2 Lg.....	2
27	N58671	Plate - Case Drain Header Mount (Tow Behind Air Cart only)	1

2015 production year to present
 41 **Serial #** C241152101 and newer.
 51 **Serial #** C251152141 and newer.
 61 **Serial #** C261152201 and newer.
 71 **Serial #** C271152101 and newer.

Frames & Hitching
Hitch - 61 Ft to 90 Ft - Prior to 2015

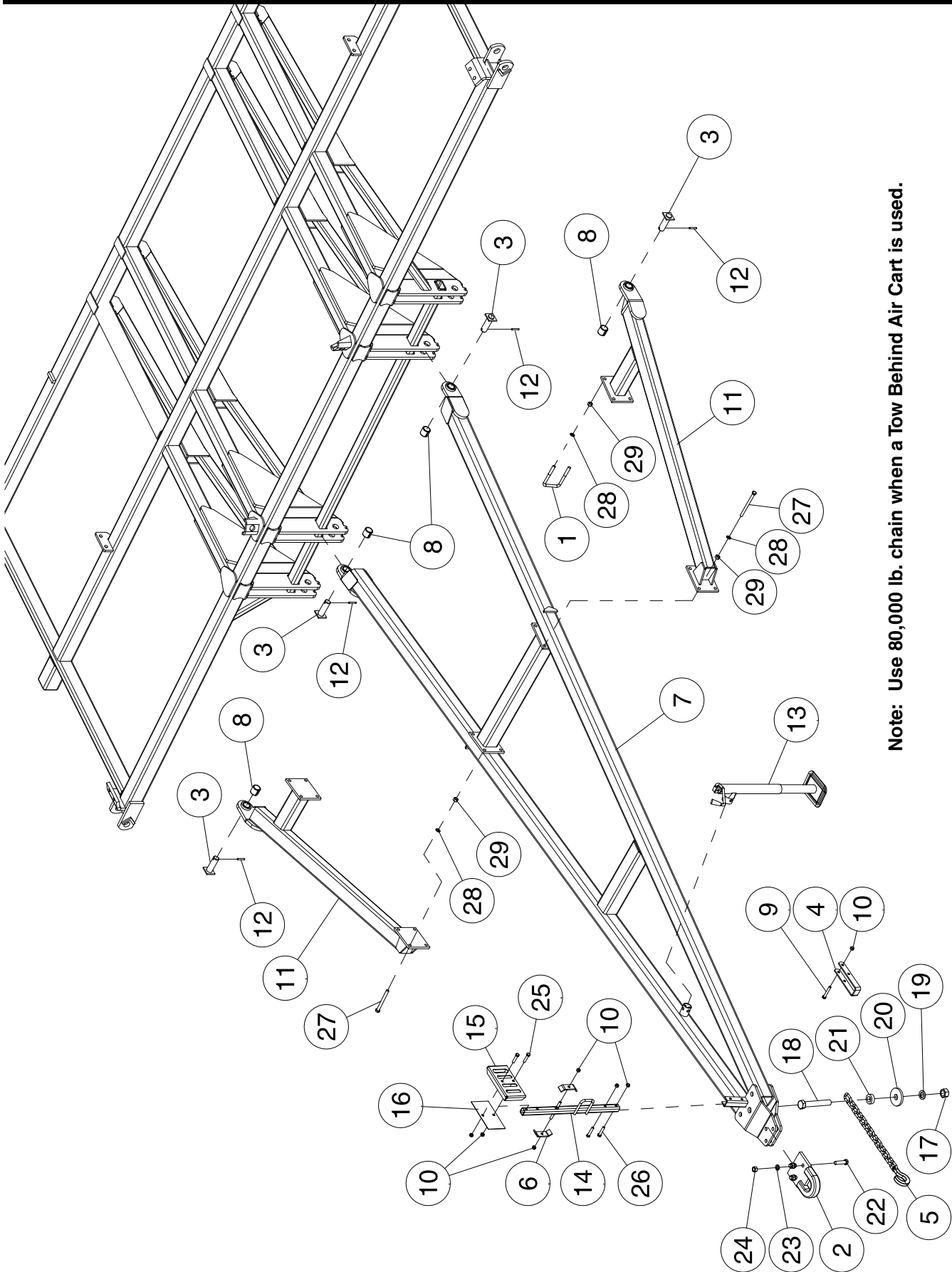

Note: Use 80,000 lb. chain when a Tow Behind Air Cart is used.

Hitch - 61 Ft to 90 Ft - Prior to 2015

Item	Part No.	Description	Qty
1	C-219	U-Bolt - 5/8 x 4 x 5 9/16	4
2	C-4438	Clevis - CAT 4	1
	S50205	Clevis - CAT 5 (2 3/4 Diameter Draw Pin)	
3	C18531	Pin - 1 3/8 Dia x 3 5/8 UL.....	2
4	C18758	Safty Chain Support.....	1
5	C18761	Safety Chain - 40,000 Lb	1
	N44710	Safety Chain - 80,000 Lb	
6	C26321	Hose Holder Clamp.....	2
7	S56450	Hitch - 5 Frame (Includes 2 of Item 8).....	1
8	S56455	Spring Bushing - 1 3/8 ID x 1 7/8 OD x 1 3/4 Lg.....	4
9	D-5519	Hex Bolt - 1/2 x 3 1/4 Lg.....	1
10	F-3405	Locknut - 1/2 Unitorque.....	7
11	S56454	Hitch Brace - 80 ft and 90 ft (Includes 1 of Item 8).....	2
12	J12281	Spiral Pin - 5/16 x 2 Lg.....	2
13	S39391	Top Wind Jack - 2000 Lb.	1
14	S39665	Hose Holder Stand.....	1
15	S39666	Hydraulic Hose Holder Plate	1
16	S39669	Back Plate.....	1
17	P61D20	Hex Nut - 1 1/4.....	1
18	S44715	Hex Bolt - 1 1/4 x 8 Lg.....	1
19	C39432	Lockwasher - 1 1/4.....	1
20	S44716	Retaining Washer - 1 5/16 ID x 4 1/4 OD x 1/2 Thick	1
21	S44717	Chain Link Spacer - 1 5/16 ID x 2 1/4 OD x 3/4 Thick - Required for 80,000 lb Chain.....	1
22	W-63	Hex Bolt - 3/4 x 3 Lg.....	3
23	W-527	Lockwasher - 3/4.....	3
24	W-518	Hex Nut - 3/4.....	3
25	W-489	Hex Bolt - 1/2 x 2 1/4 Lg.....	2
26	W-490	Hex Bolt - 1/2 x 2 1/2 Lg.....	2
27	C-507	Hex Bolt - 5/8 x 6 Lg - 80 ft to 90 ft.....	8
28	W-526	Lockwasher - 5/8 - 80 ft to 90 ft.....	16
29	W-517	Hex Nut - 5/8 - 80 ft to 90 ft.....	16

Prior to 2015 production year
 61 **Serial #** C261142190 and older.
 71 **Serial #** C271142095 and older.
 80 **Serial #** C280142043 and older.
 86 **Serial #** C286142046 and older.
 90 **Serial #** C290143006 and older.

Frames & Hitching Hitch - 80 Ft to 90 Ft - 2015 to Present

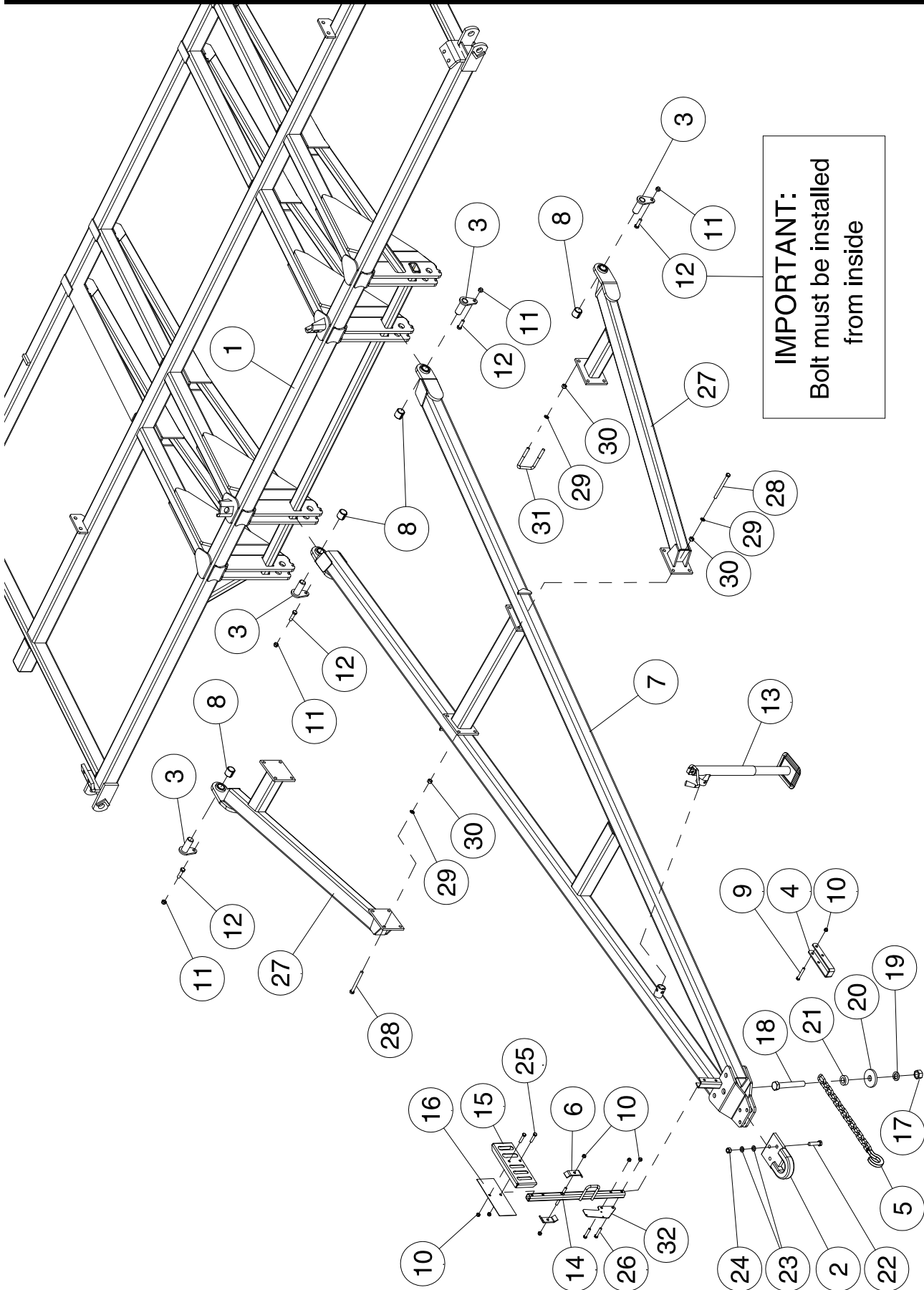

Hitch - 80 Ft to 90 Ft - 2015 to Present

Item	Part No.	Description	Qty
1	S55914	Main Frame - 21 FT - C2.....	1
2	C-4438	Clevis - CAT 4	1
	S50205	Clevis - CAT 5 (2 3/4 Diameter Draw Pin)	
3	S55909	Pin - 1 1/2 Dia x 3 11/16 UL	4
4	C18758	Safty Chain Support.....	1
5	N44710	Safety Chain - 80,000 Lb	1
6	C26321	Hose Holder Clamp.....	2
7	S55900	Hitch - 5 Frame (Includes 2 of Item 8).....	1
8	S55309	Spring Bushing - 1 1/2 ID x 1 7/8 OD x 1 3/4 Lg.....	4
9	D-5519	Hex Bolt - 1/2 x 3 1/4 Lg.....	1
10	F-3405	Locknut - 1/2 Uunitorque.....	7
11	S-1197	Locknut - 5/8 Uunitorque.....	4
12	W-499	Hex Bolt - 5/8 x 2 Lg.....	4
13	S39391	Top Wind Jack - 2000 Lb.	1
14	S39665	Hose Holder Stand.....	1
15	S39666	Hydraulic Hose Holder Plate - 4 Slot - Single Fan.....	1
	S62722	Hydraulic Hose Holder Plate - 5 Slot - Dual Fan	
16	S39669	Back Plate - 4 Slot - Single Fan	1
	S62723	Back Plate - 5 Slot - Dual Fan	
17	P61D20	Hex Nut - 1 1/4.....	1
18	S44715	Hex Bolt - 1 1/4 x 8 Lg.....	1
19	C39432	Lockwasher - 1 1/4.....	1
20	S44716	Retaining Washer - 1 5/16 ID x 4 1/4 OD x 1/2 Thick	1
21	S44717	Chain Link Spacer - 1 5/16 ID x 2 1/4 OD x 3/4 Thick - Required for 80,000 lb Chain.....	1
22	11576	Hex Bolt - 3/4 x 3 1/2 Lg Grade 8	3
23	W-476	Flat Washer - 13/16 ID x 1 7/16 OD x 11GA.....	6
24	D-5273	Lock Nut - 3/4.....	3
25	W-489	Hex Bolt - 1/2 x 2 1/4 Lg.....	2
26	W-490	Hex Bolt - 1/2 x 2 1/2 Lg.....	2
27	S55910	Hitch Brace - 80 ft and 86 ft (Includes 1 of Item 8).....	2
28	C-507	Hex Bolt - 5/8 x 6 Lg - 80 ft to 90 ft.....	8
29	W-526	Lockwasher - 5/8 - 80 ft to 90 ft.....	16
30	W-517	Hex Nut - 5/8 - 80 ft to 90 ft	16
31	C-219	U-Bolt - 5/8 x 4 x 5 9/16	4
32	N58671	Plate - Case Drain Header Mount (Tow Behind Air Cart only).....	1

2015 production year to present

80 **Serial #** C280152051 and newer.

86 **Serial #** C286152061 and newer.

90 **Serial #** C290153011 and newer.

Frames & Hitching Hitch - 25 & 31Ft Contour

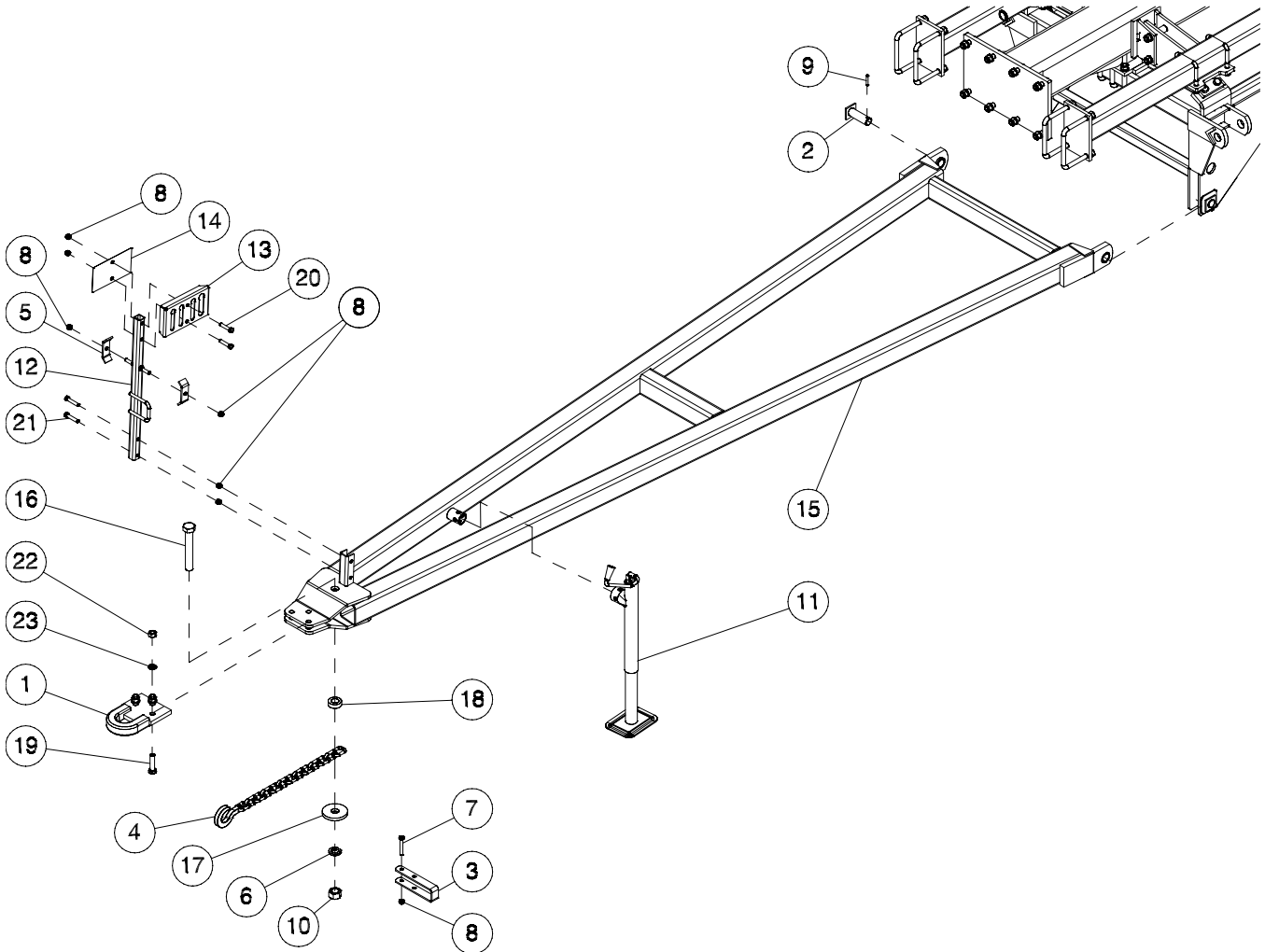

Item	Part No.	Description	Qty
1	C-4438	Clevis	1
2	C18531	Pin - 1 3/8 Dia x 3 5/8 UL.....	2
3	C18758	Safaty Chain Support.....	1
4	C18761	Safety Chain - 40,000 Lb	1
5	C26321	Hose Holder Clamp.....	2
6	C39432	Lockwasher - 1 1/4.....	1
7	D-5519	Hex Bolt - 1/2 x 3 1/4 Lg.....	1
8	F-3405	Locknut - 1/2 Unitorque.....	7
9	J12281	Spiral Pin - 5/16 x 2 Lg.....	2
10	P61D20	Hex Nut - 1 1/4.....	1
11	S39391	Top Wind Jack	1
12	S39665	Stand.....	1
13	S39666	Plate.....	1
14	S39669	Back Plate.....	1
15	S44496	Hitch 3 Meter Transport	1
16	S44715	Hex Bolt - 1 1/4 x 8 Lg.....	1
17	S44716	Retaining Washer - 1 5/16 ID x 4 1/4 OD x 1/2 Thick	1
18	S44717	Chain Link Spacer - 1 5/16 ID x 2 1/4 OD x 3/4 Thick - Required for 80,000 lb Chain.....	1
19	W-63	Hex Bolt - 3/4 x 3 Lg.....	3
20	W-489	Hex Bolt - 1/2 x 2 1/4 Lg.....	2
21	W-490	Hex Bolt - 1/2 x 2 1/2 Lg.....	2
22	W-518	Hex Nut - 3/4	33
23	W-527	Lockwasher - 3/4.....	33

Frames & Hitching Main Frame Front Axle Castor - 41 Ft to 90 Ft

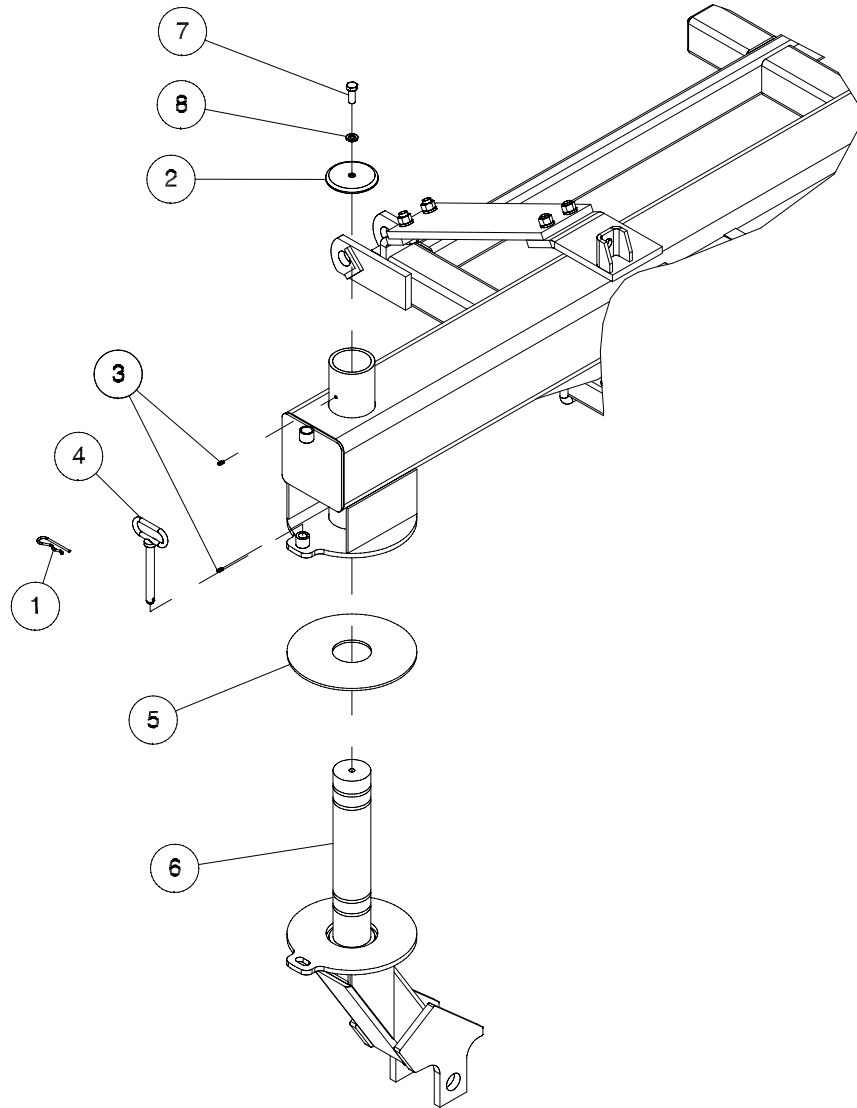

Item	Part No.	Description	Qty
1	BW-11	Hairpin - 3/16.....	2
2	C18781	Cap - 3 1/2	2
3	S-752	Grease Zerk - 1/4.....	4
4	S33404	Lock Pin	2
5	S39728	Wear Plate - 3 5/8 ID x 12 OD.....	2
6	S44309	Castor Fork - 41 to 71	2
	S53265	Castor Fork - 61 & 71 with optional 16.5L tires	2
	S53265	Castor Fork - 80 to 90	2
7	W-497	Hex Bolt - 5/8 x 1-1/2 Lg.....	2
8	W-526	Lockwasher - 5/8.....	2

Frames & Hitching Main Frame - 25 & 31Ft Contour

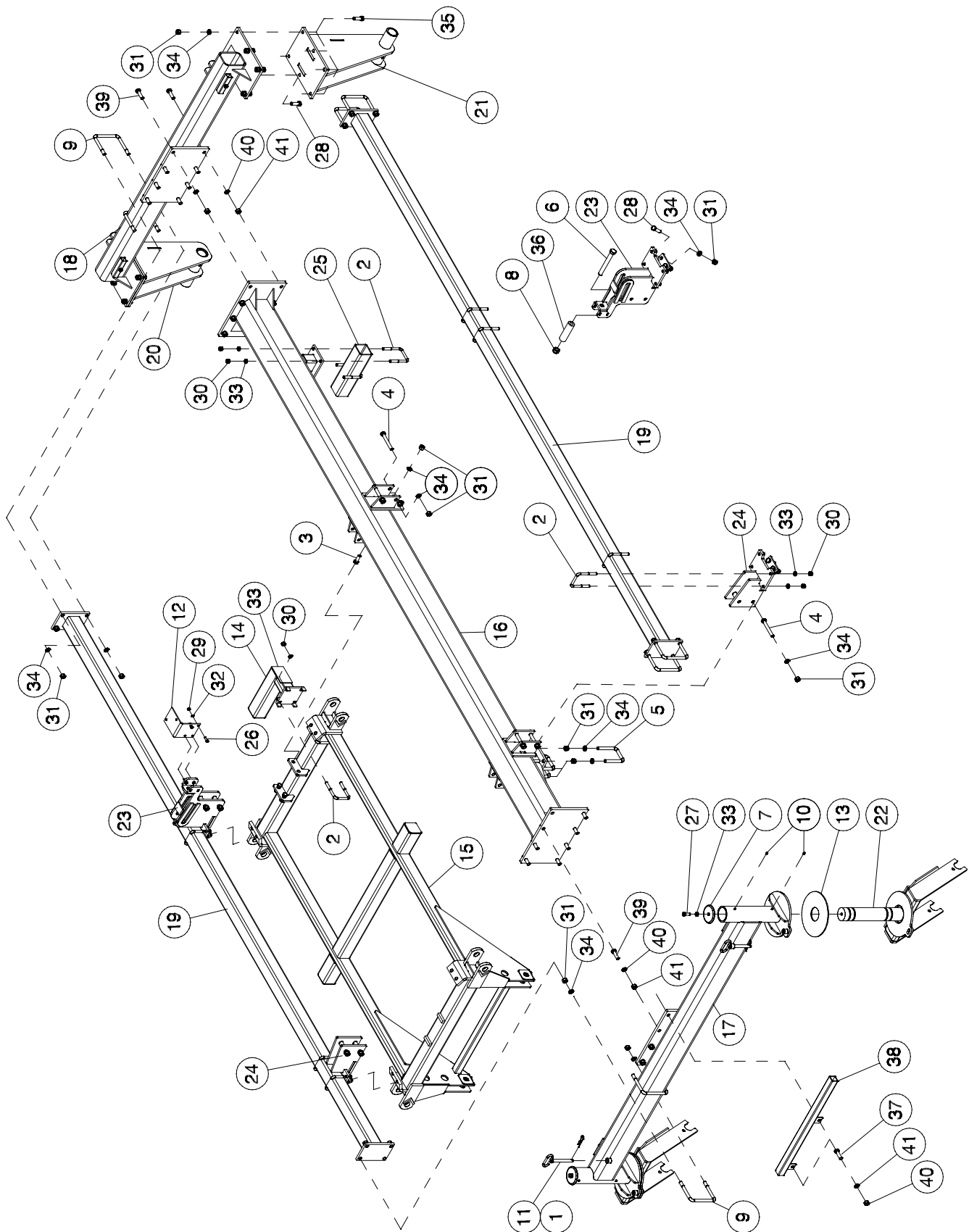

25 & 31 Foot - Main Frame

Item	Part No.	Description	Qty
1	BW-11	Hairpin - 3/16.....	2
2	C-219	U-Bolt - 5/8 x 4 x 5 9/16	10
3	C-695	Hex Bolt - 3/4 x 2 Lg.....	4
4	C-3919	Hex Bolt - 3/4 x 5 1/2 Lg.....	8
5	C-5561	U-Bolt - 3/4 x 4 x 5 9/16	5
6	C18597	Hex Bolt - 1 x 8 Lg.....	1
7	C18781	Cap - 3 1/2	2
8	D-5274	Locknut - 1 Unitorque.....	1
9	N34626	U-Bolt - 3/4 x 7 x 6 1/2	8
10	S-752	Grease Zerk - 1/4.....	4
11	S33404	Lock Pin	2
12	S39565	Valve Mounting Plate.....	1
13	S39728	Wear Plate.....	2
14	S51022	Extention Stub.....	1
15	S44489	Main Frame	1
16	S44491	Main Depth Beam	1
17	S44493	Front Axle Tube - Prior to Sept. 2012	1
	S51023	Front Axle Tube - 3 Lift	1
18	S44495	Rear Axle Tube	1
19	S44902	Brace Tube.....	2
20	S44962	Rear Axle Bracket - LT - Prior to Sept. 2012	1
	S51013	Rear Axle Bracket - 3 Lift - LT.....	1
21	S44963	Rear Axle Bracket - LT - Prior to Sept. 2012	1
	S51014	Rear Axle Bracket - 3 Lift - RT.....	1
22	S44965	Castor Fork - Main.....	2
23	S44969	Wing Lift Bracket	2
24	S44971	Wing Lift Bracket	2
25	S49886	Tube - 17 3/4 Lg	1
26	W-187	Hex Bolt - 3/8 x 1 1/4 Lg.....	4
27	W-497	Hex Bolt - 5/8 x 1 1/2 Lg.....	2
28	W-509	Hex Bolt - 3/4 x 2 1/2 Lg.....	12
29	W-514	Hex Nut - 3/8	4
30	W-517	Hex Nut - 5/8	22
31	W-518	Hex Nut - 3/4	74
32	W-523	Lockwasher - 3/8.....	4
33	W-526	Lockwasher - 5/8.....	22
34	W-527	Lockwasher - 3/4.....	74
35	W-1553	Hex Head Bolt - 3/4 x 2 1/4 Lg	10
36	S45277	Spacer - 1.031 ID x 1 1/2 OD x 5 1/2 Lg	1
37	K-5478	Hex Head Bolt - 1 x 3 1/2 Lg.....	2
38	S45250	Valve Mount Bracket.....	1
39	J12344	Hex Bolt - 1 x 3 Lg.....	14
40	C-705	Lockwasher - 1.....	16
41	W-520	Hex Nut - 1.....	16

Prior to Sept. 2012

31' Prior to serial # C231132012

Frames & Hitching Main Depth Beams - 41 Ft to 90 Ft

Prior to Sept. 2012

41' Prior to serial # C241132025

51' Prior to serial # C251132035

61' Prior to serial # C261132067

71' Prior to serial # C271132031

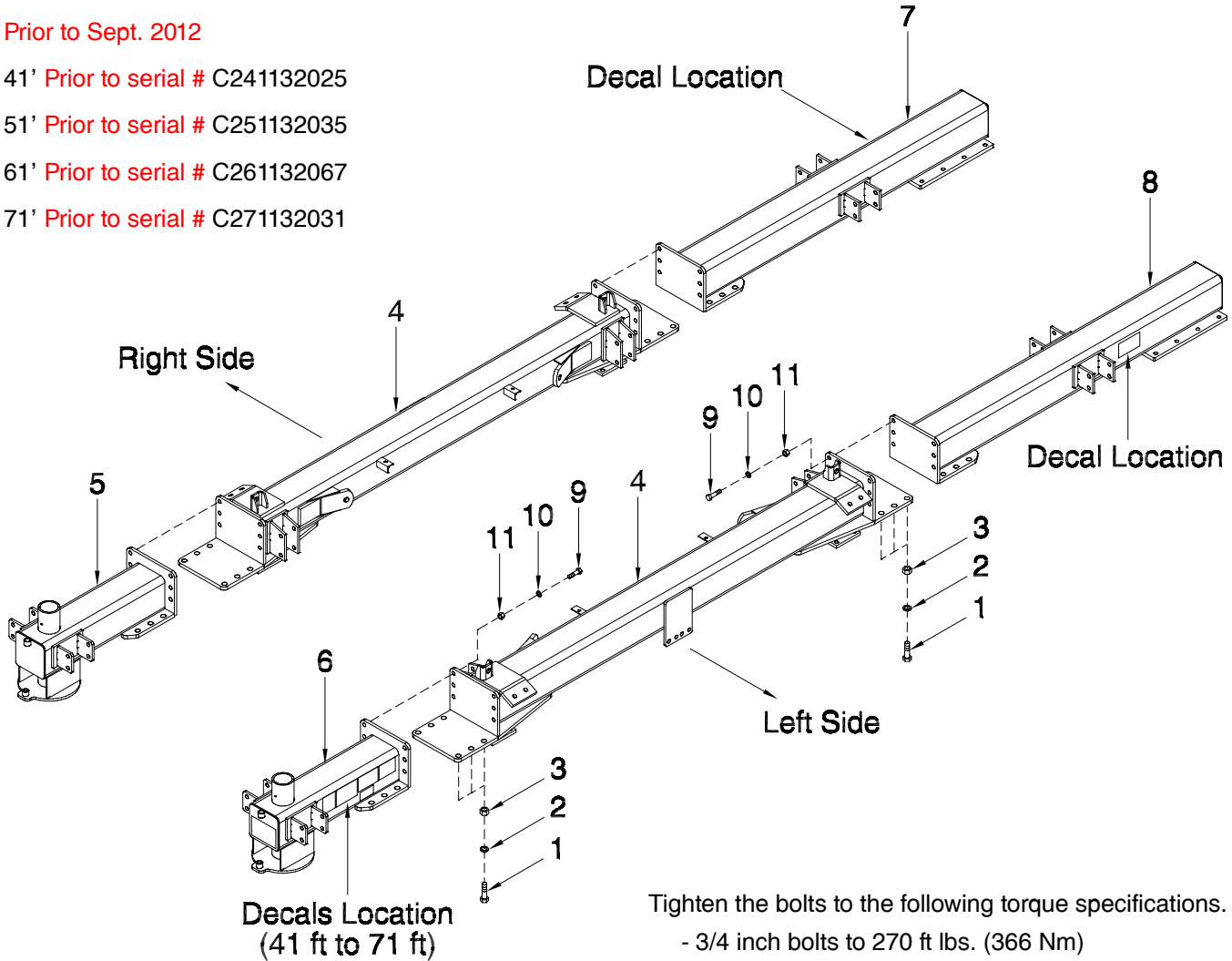

Tighten the bolts to the following torque specifications.

- 3/4 inch bolts to 270 ft lbs. (366 Nm)
- 1 inch bolts to 590 ft lbs. (800 Nm)

Item	Part No.	Description	Qty
1	J12344	Hex Bolt - 1 x 3 Lg.....	24
2	C-705	Lockwasher - 1.....	24
3	W-520	Hex Nut - 1.....	24
4	S45797	Center Main Depth Tube - 41 to 71.....	2
	S47070	Center Main Depth Tube - 80 & 86.....	2
	S47630	Front Main Depth Tube - Right - 41 to 71 - Prior to Sept. 2012	1
5	S51010	Front Main Depth Tube - Right - 41 to 71.....	1
	S45902	Front Main Depth Tube - 80 to 90 - (61 & 71 with optional 16.5L tires).....	1
	S47630	Front Main Depth Tube - Left - 41 to 71 - Prior to Sept. 2012	1
6	S51010	Front Main Depth Tube - Left - 41 to 71.....	1
	S45902	Front Main Depth Tube - 80 to 90 - (61 & 71 with optional 16.5L tires).....	1
	S45903	Rear Main Depth Tube.....	1
7	S45903	Rear Main Depth Tube.....	1
8	S45903	Rear Main Depth Tube.....	1
9	W-509	Hex Bolt - 3/4 x 2 1/2 Lg.....	24
10	W-527	Lockwasher - 3/4.....	24
11	W-518	Hex Nut - 3/4.....	24

Frames & Hitching Main Frame & Depth Beams - 41 Ft to 71 Ft

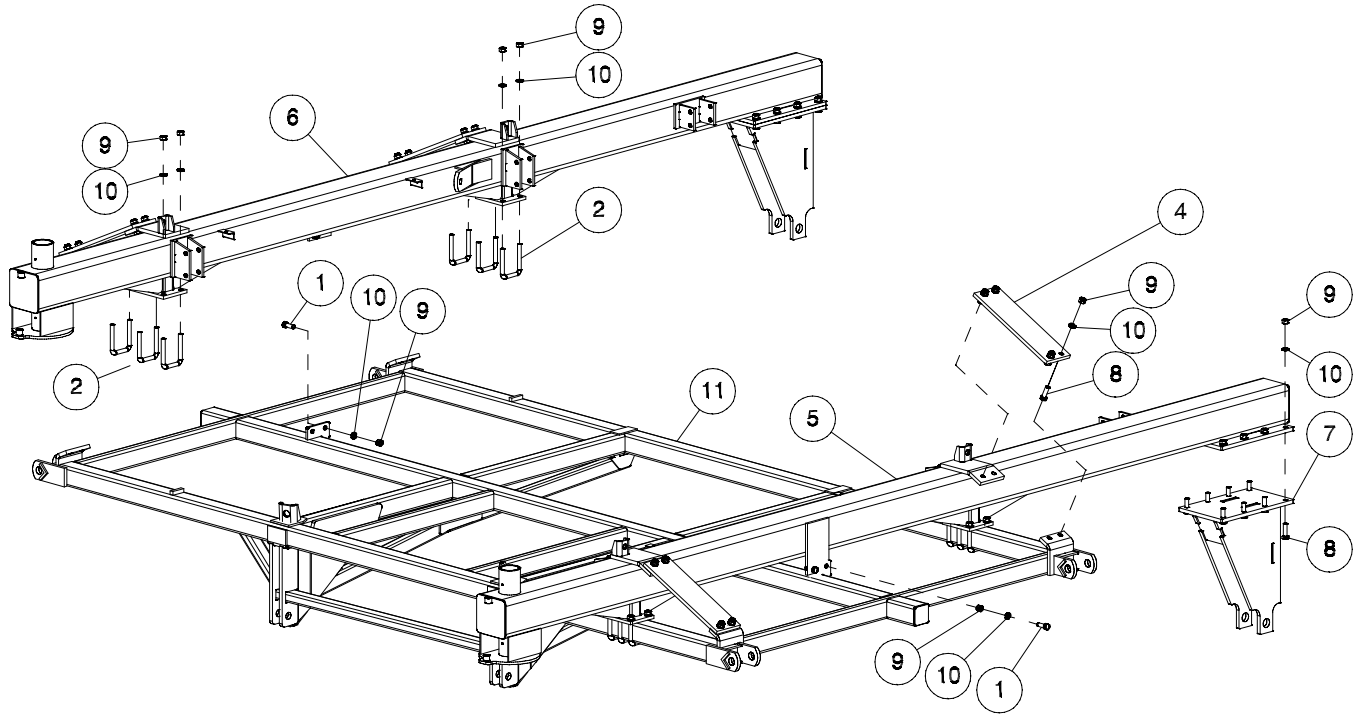

Prior to Sept. 2012

41' Prior to serial # C241132025

51' Prior to serial # C251132035

61' Prior to serial # C261132067

71' Prior to serial # C271132031

Item	Part No.	Description	Qty
1	C-695	Hex Bolt - 3/4 x 2 Lg.....	4
2	C-5561	U-bolt - 3/4 x 4 x 5 9/16.....	12
3	C31361	Spherical Nut 1 1/4	2
4	S42622	Brace Plate.....	4
5	*****	Left Main Depth Tube - See Page 1-14	1
6	*****	Right Main Depth Tube - See Page 1-14.....	1
7	S42900	Rear Main Axle - Standard - 24 3/4 Lg - 41 to 71 - Prior to Sept. 2012	2
	S51020	Rear Main Axle - Standard - 26 3/4 Lg - 41 to 71.....	2
	S47080	Rear Main Axle - 61 & 71 with optional 16.5L tires - Prior to Sept. 2013	2
	S53264	Rear Main Axle - 61 & 71 with optional 16.5L tires	2
8	W-509	Hex Bolt - 3/4 x 2 1/2 Lg.....	32
9	W-518	Hex Nut - 3/4.....	60
10	W-527	Lockwasher - 3/4.....	60
11	S55913	Main Frame - 16 FT - C2 - 41 to 71	1

Frames & Hitching Main Frame & Depth Beams - 80 Ft to 90 Ft

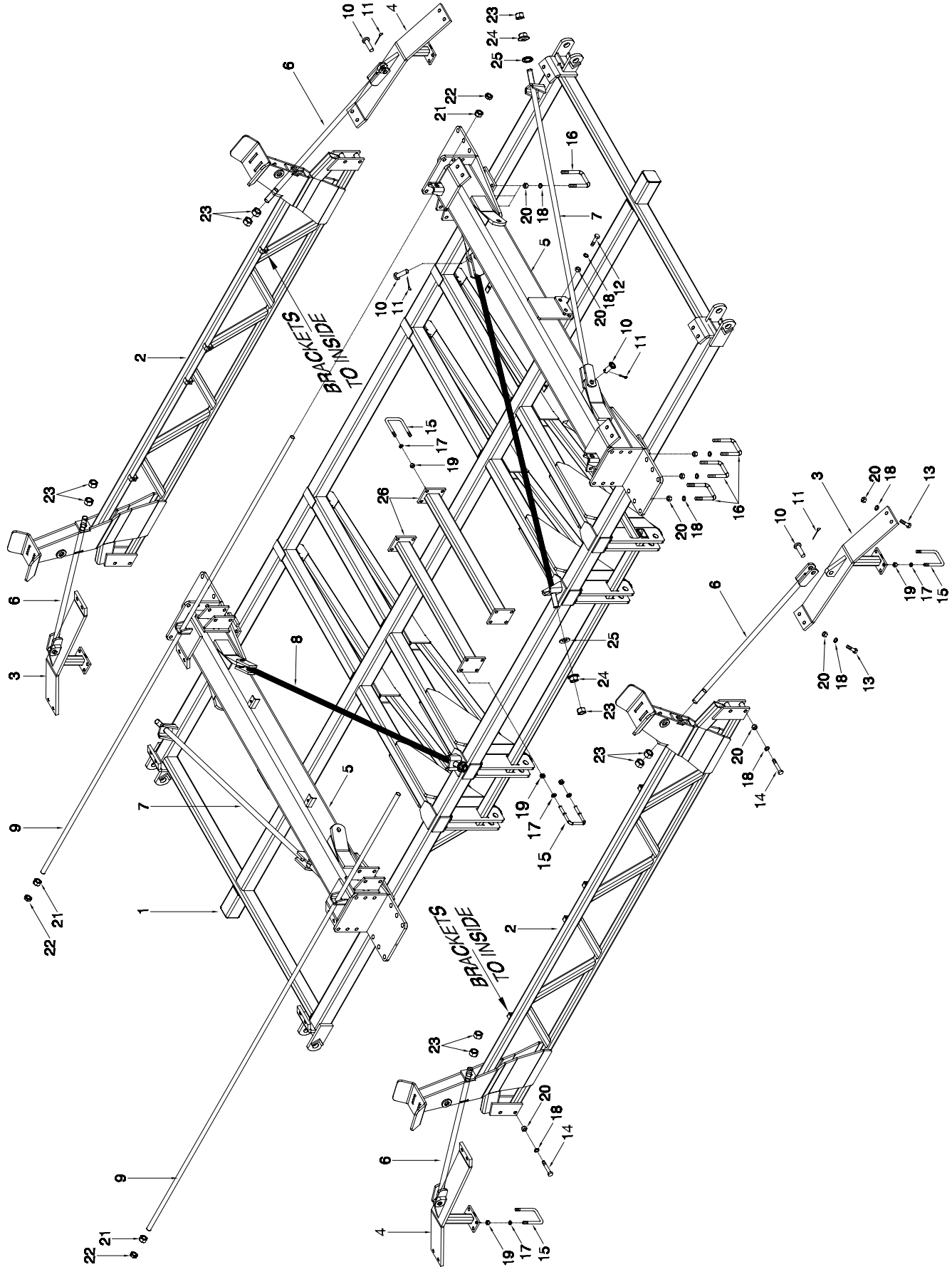

80 Ft to 90 Ft - Main Frame

Item	Part No.	Description	Qty
1	S55914	Main Frame - 21 FT - C2.....	1
2	S45289	Wing Lift Truss - Main	2
3	S45913	Hinge Brace - Left	2
4	S45915	Hinge Brace - Right.....	2
5	*****	Main Depth Tube (See Page 1-14)	2
6	S45917	Tie Rod - 1 1/4 Dia x 48 UL.....	2
7	S42649	Tie Rod - 1 1/4 Dia x 84 1/2 UL.....	2
8	S47506	Tie Rod - 1 1/4 Dia x 90 UL.....	2
9	S45791	Truss Rod - 159 Lg	2
10	W-558	Pin - 1 x 2 1/4 UL	8
11	W-535	Cotter Pin - 1/4 x 1 1/2 Lg	8
12	C-695	Hex Bolt - 3/4 x 2 Lg.....	4
13	W-509	Hex Bolt - 3/4 x 2 1/2 Lg.....	16
14	S-1191	Hex Bolt - 3/4 x 5 Lg.....	8
15	C-219	U-Bolt - 5/8 x 4 x 5 9/16	8
16	C-5561	U-bolt - 3/4 x 4 x 5 9/16.....	12
17	W-526	Lockwasher - 5/8.....	16
18	W-527	Lockwasher - 3/4.....	52
19	W-517	Hex Nut - 5/8	16
20	W-518	Hex Nut - 3/4	52
21	W-520	Hex Nut - 1	8
22	S-711	Jam Nut - 1	4
23	P61D20	Hex Nut - 1 1/4.....	12
24	C31361	Spherical Nut - 1 1/4	4
25	C15767	Spherical Washer - 2 1/2 Dia	4
26	S42714	Frame Spacer.....	2

Frames & Hitching

Main Frame Front and Rear Hitch Beam - 80 Ft to 90 Ft

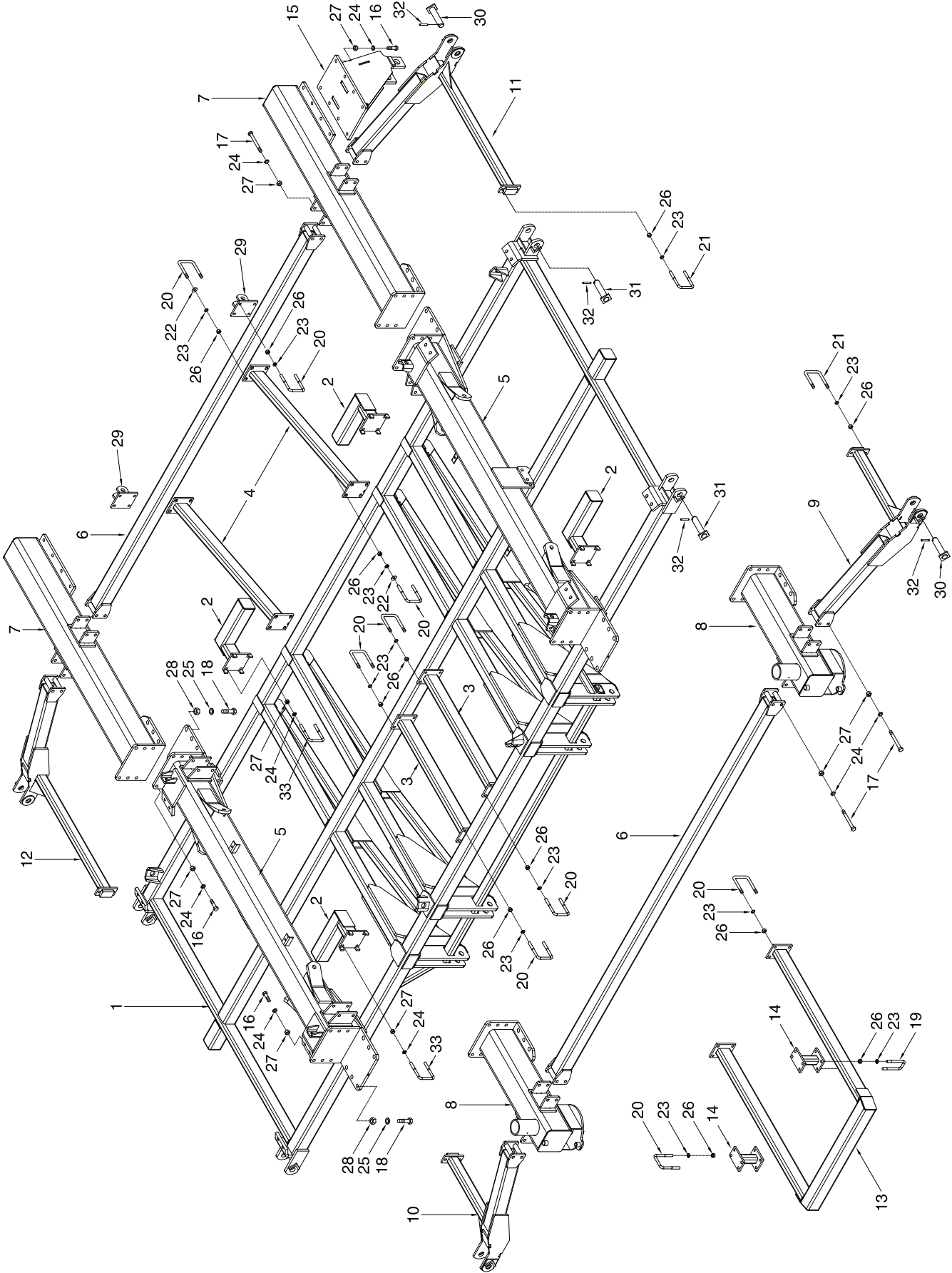

80 Ft to 90 Ft - Main Frame Front and Rear Hitch Beam

Item	Part No.	Description	Qty
1	S55914	Main Frame - 21 FT - C2.....	1
2	S51022	HD Extension Stub.....	4
	S44314	Extension Stub - Prior to September 2012 (Uses C-219 U-Bolt)	4
3	S42714	Frame Spacer.....	2
4	S42964	Rear Tow Hitch Brace	2
5	S47070	Main Depth Tube (See Next Page)	2
6	S45297	Hitch Cross Member	2
7	S45903	Rear Main Depth Tube - 80 & 86	2
8	S45902	Front Main Depth Tube - 80 & 86.....	2
9	S45921	Front Hinge Brace - Left	1
10	S45922	Front Hinge Brace - Right.....	1
11	S45941	Rear Hinge Brace - Left.....	1
12	S47517	Rear Hinge Brace - Right.....	1
13	S49835	Trip Mounting Frame.....	1
14	S47589	Spacer.....	2
15	S47080	Main Axle - Rear - Prior to September 2013.....	2
	S53264	Main Axle - Rear	2
16	W-509	Hex Bolt - 3/4 x 2 1/2 Lg.....	40
17	C-3917	Hex Bolt - 3/4 x 7 Lg.....	16
18	J12344	Hex Bolt - 1 x 3 Lg.....	24
19	D-4931	U-Bolt - 5/8 x 2 x 5 1/2	4
20	C-219	U-Bolt - 5/8 x 4 x 5 9/16	28
21	N37512	U-Bolt - 5/8 x 4 x 6 1/4	4
22	W-629	Flatwasher - 5/8	16
23	W-526	Lockwasher - 5/8.....	72
24	W-527	Lockwasher - 3/4.....	72
25	C-705	Lockwasher - 1	24
26	W-517	Hex Nut - 5/8.....	72
27	W-518	Hex Nut - 3/4	72
28	W-520	Hex Nut - 1	24
29	N19203	Mounting Bracket	2
30	S47518	Pin - 1 1/2 Dia x 5 5/8 UL.....	4
31	S42725	Pin - 1 1/2 Dia x 6 3/8 UL.....	4
32	T-5245	Spiral Pin - 3/8 x 2 1/2.....	8
33	C-5561	U-Bolt - 3/4 x 4 x 5 9/16	8

Prior to Sept. 2012

80' Prior to serial # C280132015

86' Prior to serial # C286132021

Frames & Hitching Front and Rear Hitch Beam - 41 Ft and 51 Ft - Prior to September 2012

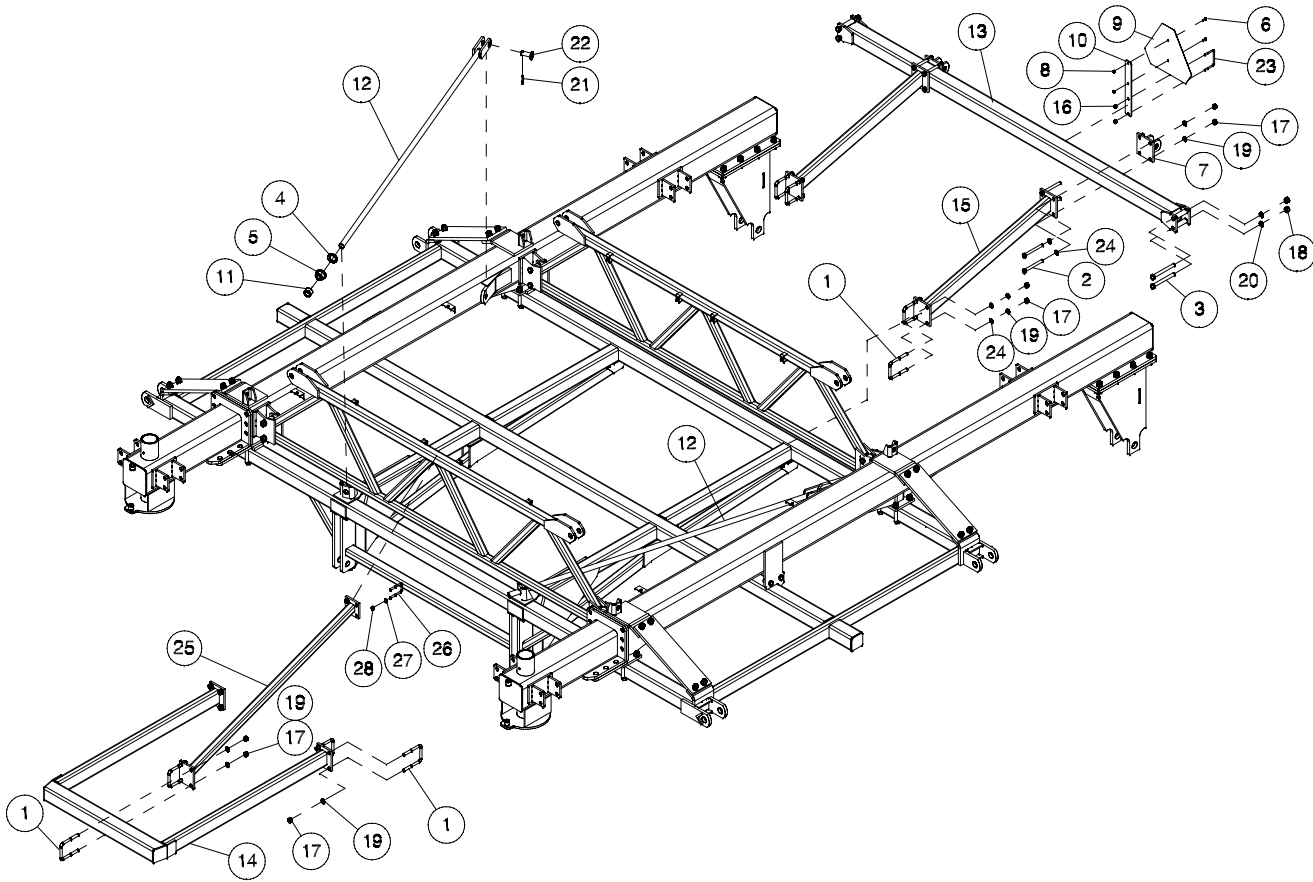

Item	Part No.	Description	Qty
1	C-219	U-Bolt - 5/8 x 4 x 5 9/16	8
2	C-507	Hex Bolt - 5/8 x 6 Lg.....	8
3	C-3917	Hex Head Bolt - 3/4 x 7 Lg.....	4
4	C15767	Spherical Washer - 2 1/2 Dia	2
5	C31361	Spherical Nut - 1 1/4	2
6	K-3830	Hex Bolt - 1/4 x 1/2 Lg.....	2
7	N19203	Mounting Bracket	2
8	N22778	Locknut - 1/4 Nylon Insert.....	2
9	N34475	Slow Moving Vehicle Emblem	1
10	N34714	Mount - SMV	1
11	P61D20	Hex Nut - 1 1/4.....	2
12	S42649	Tie Rod - 1 1/4 Dia x 84 1/2 UL	2
13	S42905	Rear Hitch Cross Member.....	1
14	S49835	Trip Mounting Frame.....	1
15	S42964	Rear Tow Hitch Brace	2
16	D-5279	Flange Locknut - 3/8	2
17	W-517	Hex Nut - 5/8	24
18	W-518	Hex Nut - 3/4.....	4
19	W-526	Lockwasher - 5/8.....	24
20	W-527	Lockwasher - 3/4.....	4
21	W-535	Cotter Pin - 1/4 x 1 1/2 Lg	2
22	W-558	Pin - 1 Dia x 2 1/4 UL.....	2
23	N15098	U-Bolt - 3/8 x 4 x 5	1
24	W-629	Flatwasher - 5/8	16
25	S49843	Brace Tube - 41 & 51	1
26	D-4825	U-Bolt - 1/2 x 2 1/2 x 3 3/4 Lg	2
27	W-525	Lockwasher - 1/2.....	4
28	W-516	Hex Nut - 1/2.....	4

Frames & Hitching Front and Rear Hitch Beam - 41 Ft to 71 Ft

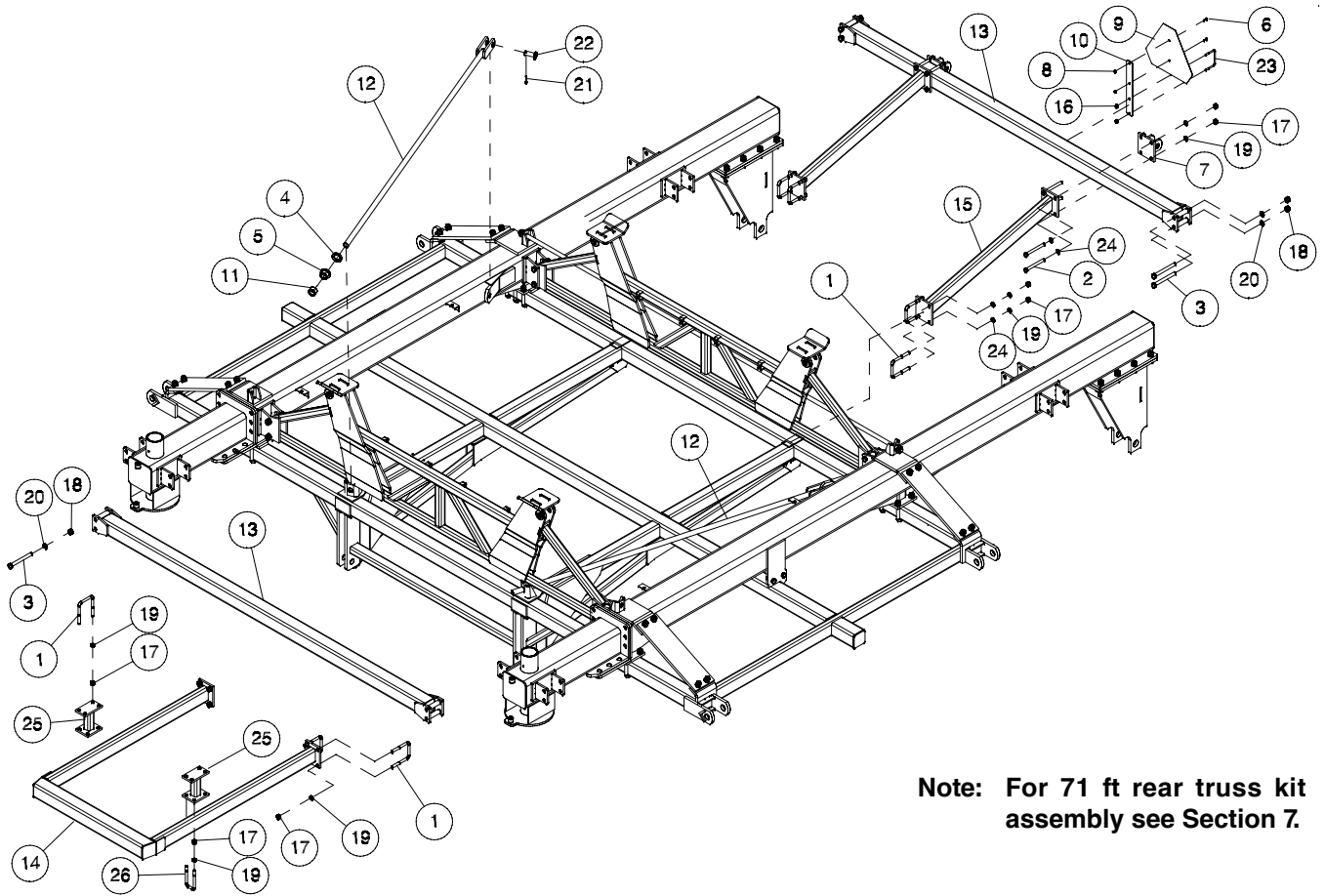

Note: For 71 ft rear truss kit assembly see Section 7.

Item	Part No.	Description	Qty
1	C-219	U-Bolt - 5/8 x 4 x 5 9/16	12
2	C-507	Hex Bolt - 5/8 x 6 Lg.....	8
3	C-3917	Hex Head Bolt - 3/4 x 7 Lg.....	8
4	C15767	Spherical Washer - 2 1/2 Dia	2
5	C31361	Spherical Nut - 1 1/4	2
6	K-3830	Hex Bolt - 1/4 x 1/2 Lg.....	2
7	N19203	Mounting Bracket	2
8	N22778	Locknut - 1/4 Nylon Insert.....	2
9	N34475	Slow Moving Vehicle Emblem	1
10	N34714	Mount - SMV	1
11	P61D20	Hex Nut - 1 1/4	2
12	S42649	Tie Rod - 1 1/4 Dia x 84 1/2 UL	2
13	S42905	Rear Hitch Cross Member.....	1
14	S49835	Trip Mounting Frame.....	1
15	S42964	Rear Tow Hitch Brace	2
16	D-5279	Flange Locknut - 3/8	2
17	W-517	Hex Nut - 5/8	36
18	W-518	Hex Nut - 3/4	8
19	W-526	Lockwasher - 5/8.....	36
20	W-527	Lockwasher - 3/4.....	8
21	W-535	Cotter Pin - 1/4 x 1 1/2 Lg	2
22	W-558	Pin - 1 Dia x 2 1/4 UL.....	2
23	N15098	U-Bolt - 3/8 x 4 x 5	1
24	W-629	Flatwasher - 5/8	16
25	S47589	Spacer.....	2
26	D-4931	U-Bolt - 5/8 x 2 x 5 1/2	2

Frames & Hitching Wing Lift, Wing Frame & Truss - 25 & 31 Ft

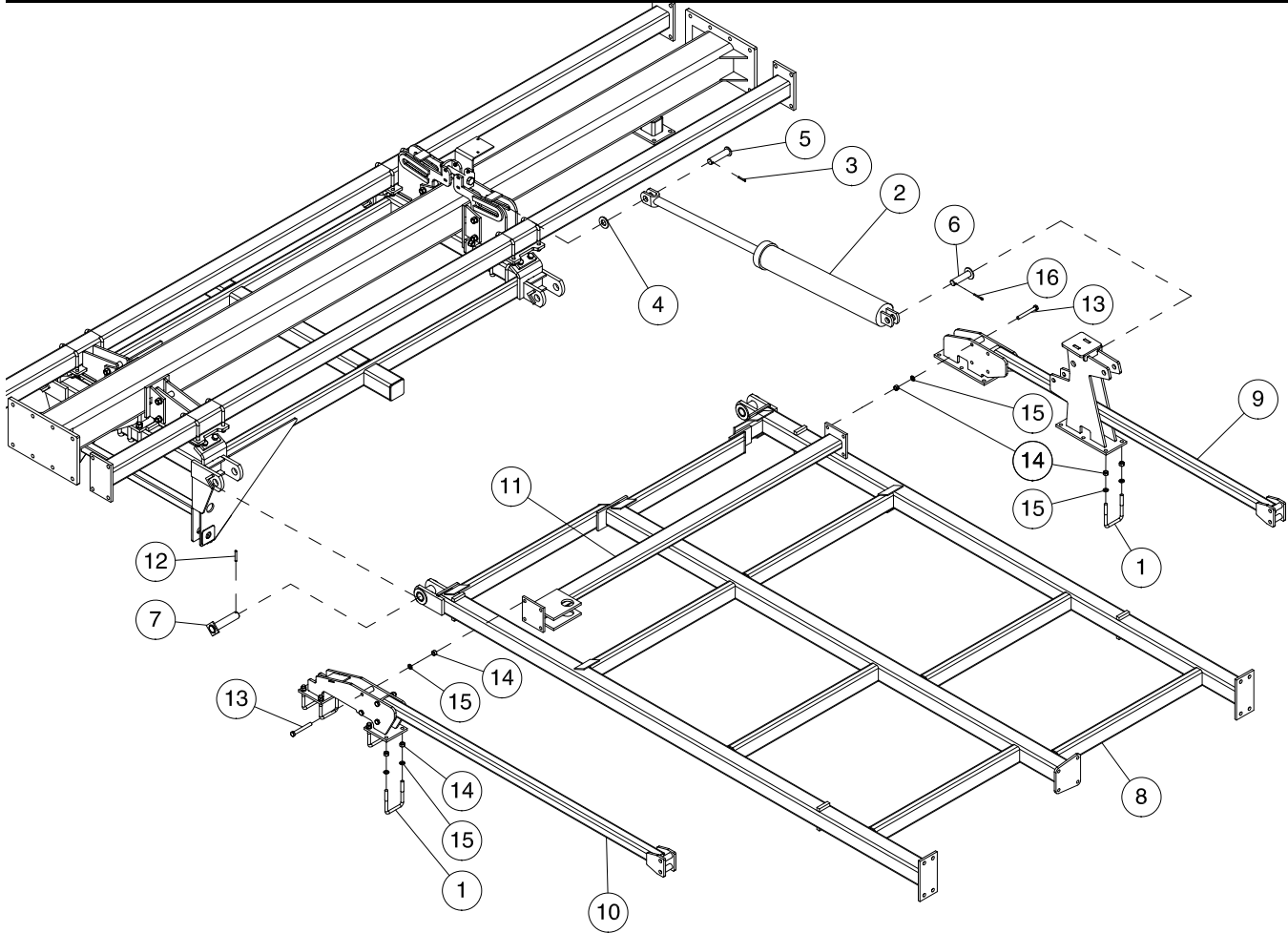

Item	Part No.	Description	Qty
1	C-219	U-Bolt - 5/8 x 4 x 5-9/16	10
2	C34442	Hydraulic Cylinder	1
3	D-5244	Spiral Pin - 1/4 x 2.....	1
4	N13962	Washer - 2-1/2 OD x 1-9/32 ID x 1/4	1
5	N28998	Pin - 1 1/4 Dia x 4 3/4 UL.....	1
6	S39543	Pin - 1 1/4 X 3 5/8 UL.....	1
7	S42725	Hinge Pin - 1 1/2 Dia x 6 3/8 UL	2
8	S49845	Inner Wing - 25 ft	1
	S49804	Inner Wing - 31 ft	1
9	S62360	Wing Truss - Rear - 25 ft.....	1
	S62358	Wing Truss - Rear - 31 ft.....	1
10	S44979	Wing Truss - Front - 25 ft.....	1
	S44922	Wing Truss - Front - 31 ft.....	1
11	S44981	Support Beam	1
12	T-5245	Spiral Pin - 3/8 x 2 1/2.....	2
13	W-506	Hex Bolt - 5/8 x 5 Lg.....	8
14	W-517	Hex Nut - 5/8	28
15	W-526	Lockwasher - 5/8.....	28
16	W-4181	Cotter Pin - 1/4 x 2 Lg	1

Frames & Hitching Wing Lift Lock - 25 & 31 Ft - Prior to 2017

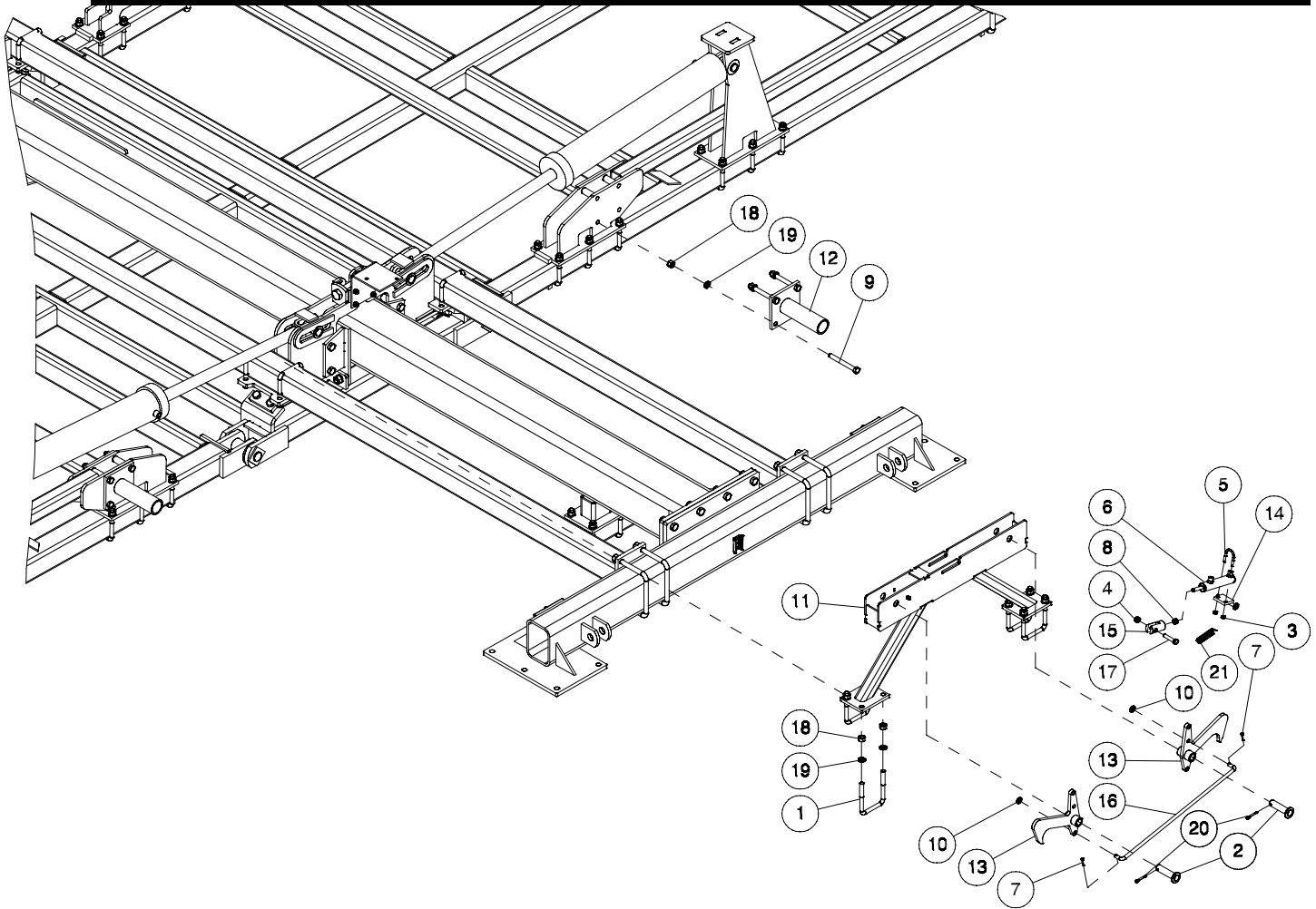

Item	Part No.	Description	Qty
1	C-219	U-Bolt - 5/8 x 4 x 5 9/16	4
2	C-1429	Pin - 1 x 3 3/8 UL	2
3	C32925	Center Locknut - 5/16.....	2
4	F-3405	Locknut - 1/2 Unitorque.....	2
5	N42091	U-bolt - 5/16 x 1 11/16 x 2 1/4	1
6	N47712	Hyd Cylinder Assembly	1
7	S-531	Cotter Pin - 3/16 x 1 Lg	2
8	S-1292	Hex Jam Nut - 1/2	1
9	S-1344	Hex Bolt - 5/8 x 5 1/2 Lg.....	8
10	S-1925	Flat Washer - 1/2.....	2
11	S47533	25/31 Transport Rest/Lock.....	1
12	S47534	Transport Stop	2
13	S47537	Hook.....	2
14	S47540	Cylinder Pivot.....	1
15	S47542	Clevis End.....	1
16	S47543	Rod - 1/2 Dia	1
17	W-489	Hex Bolt - 1/2 x 2 1/4 Lg.....	1
18	W-517	Hex Nut - 5/8.....	16
19	W-526	Lockwasher - 5/8.....	16
20	W-535	Cotter Pin - 1/4 x 1 1/2 Lg	2
21	W-1663	Adjusting Spring.....	1

Frames & Hitching Wing Lift Lock - 25 & 31 Ft - 2017

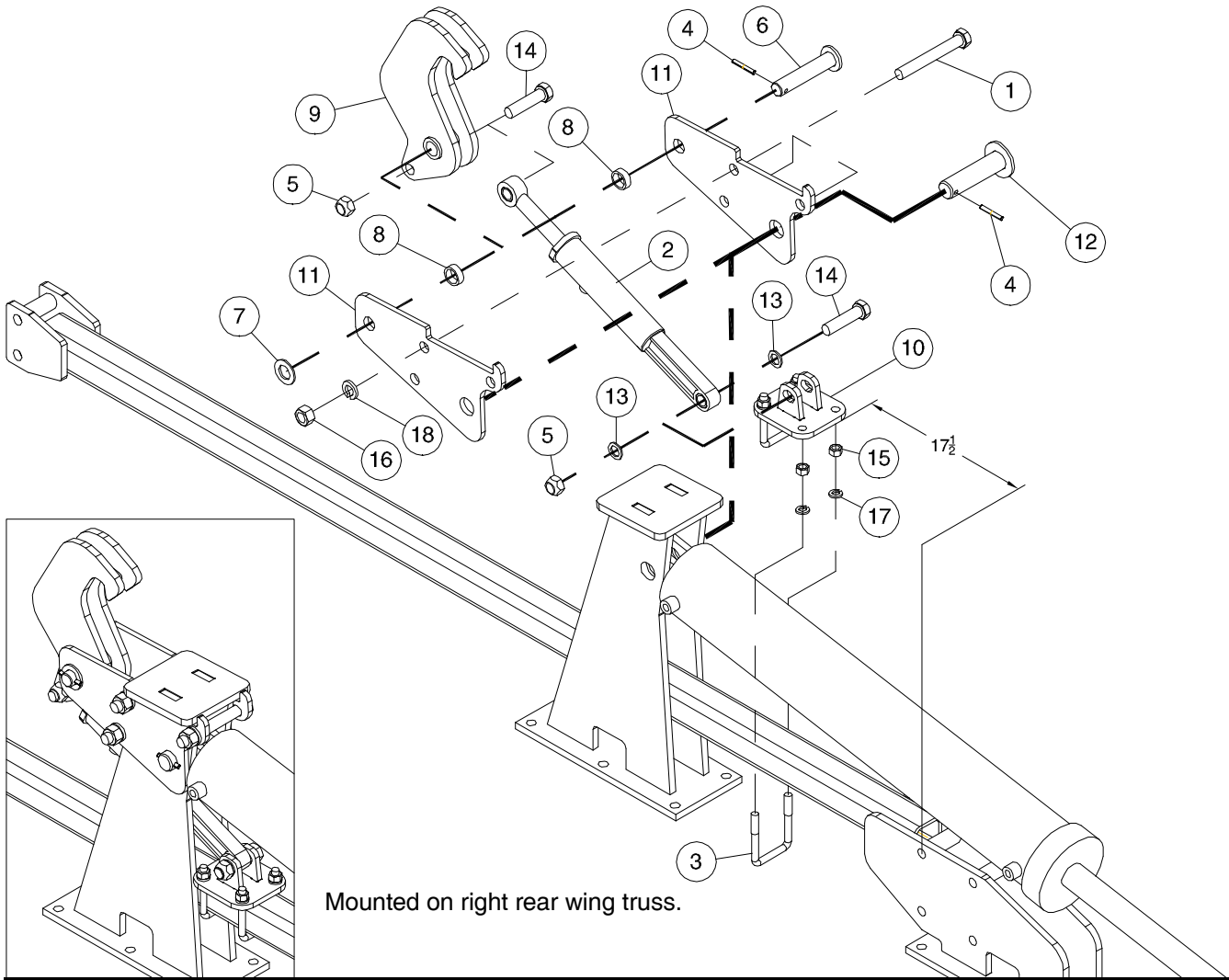

Item	Part No.	Description	Qty
1	C-3919	Hex Bolt - 3/4 x 5 1/2 Lg.....	3
2	C51153	Hydraulic Cylinder - 1 3/4 Bore x 4 Stroke	1
3	D-4825	U-Bolt - 1/2 x 2-1/2 x 3-3/4.....	2
4	D-5244	Spiral Pin - 1/4 x 2 Lg	2
5	D-5273	Locknut - 3/4 Unitorque.....	2
6	F-1713	Pin - 1 Dia x 4-3/8 UL.....	1
7	H18268	Washer - 1 1/32 ID x 1 3/4 OD x 10 Ga	1
8	N16610	Spacer - 1.049 ID x 1.315 OD x 7/16 Lg	2
9	N60885	Hook.....	1
10	N62355	Mount Bracket.....	1
11	N62356	Pivot Plate.....	2
12	S39545	Pin - 1 1/4 x 4 5/16 UL	1
13	S39559	Washer - 25/32 ID x 1 3/16 OD x 12 Ga.....	2
14	W-63	Hex Bolt - 3/4 x 3 Lg.....	2
15	W-516	Hex Nut - 1/2	4
16	W-518	Hex Nut - 3/4.....	3
17	W-525	Lockwasher - 1/2.....	4
18	W-527	Lockwasher - 3/4.....	3
	S57774	Transport Lock - Field Kit (Includes above items plus required Hydraulic components to convert Pre 2017 units.	

**Frames & Hitching
Wing Lift Lock - 25 & 31 Ft - 2018 to present**

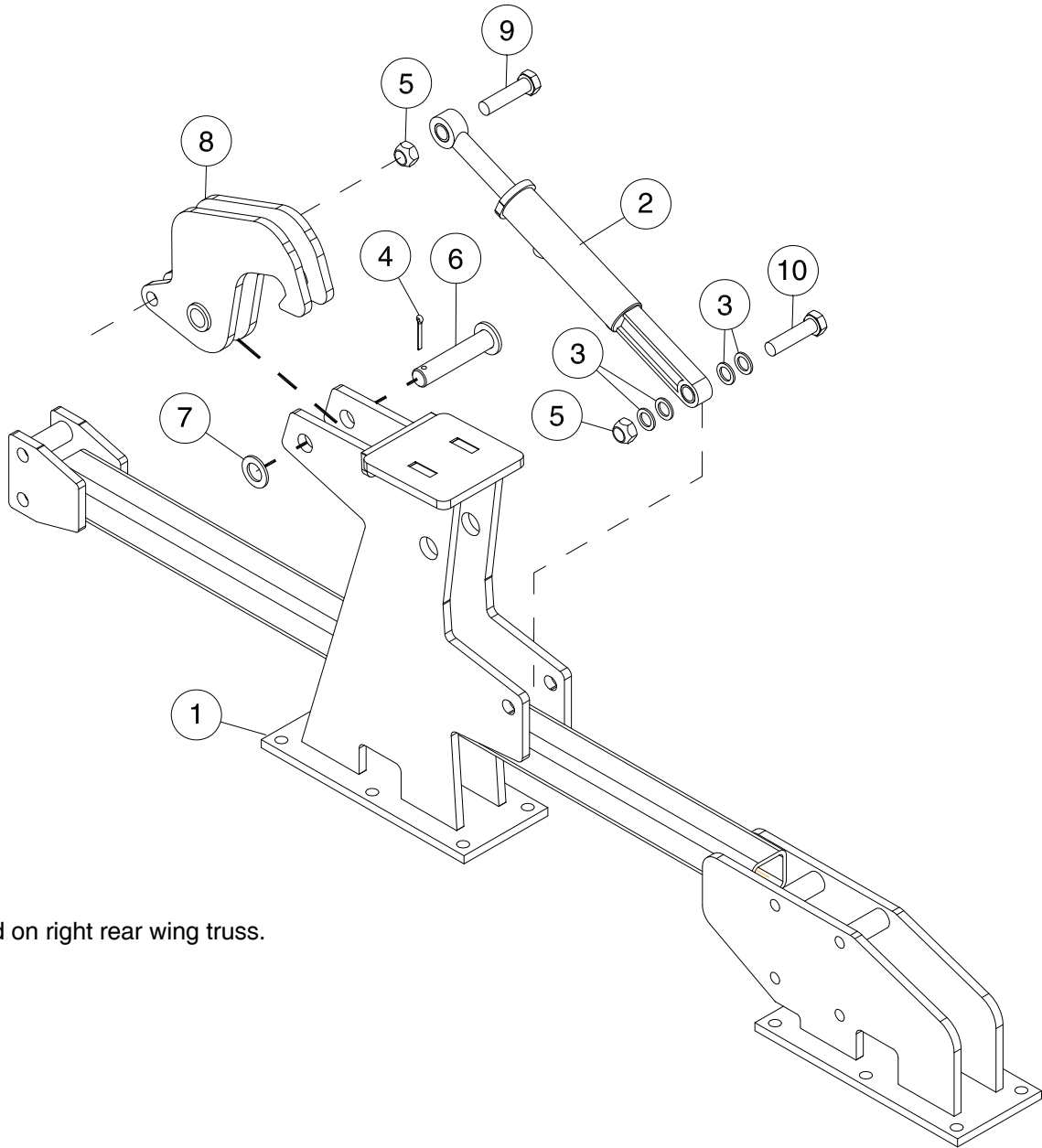

Mounted on right rear wing truss.

Item	Part No.	Description	Qty
1	S62360	Wing Truss - Rear - 25 ft (Shown).....	1
	S62358	Wing Truss - Rear - 31 ft	
2	C51153	Hydraulic Cylinder - 1 3/4 Bore x 4 Stroke	1
3	S39559	Washer - 25/32 ID x 1 3/16 OD x 12 Ga.....	6
4	W-4181	Cotter Pin - 1/4 x 2 Lg	2
5	D-5273	Locknut - 3/4 Unitorque.....	2
6	W-1628	Pin - 1 Dia x 3 3/4 UL.....	1
7	H18268	Washer - 1 1/32 ID x 1 3/4 OD x 10 Ga	1
8	N60885	Hook.....	1
9	W-63	Hex Bolt - 3/4 x 3 Lg.....	1
10	S-1175	Hex Bolt - 3/4 x 4 1/2 Lg.....	1

Frames & Hitching Wing Frame Depth Beams - 25 & 31 Ft

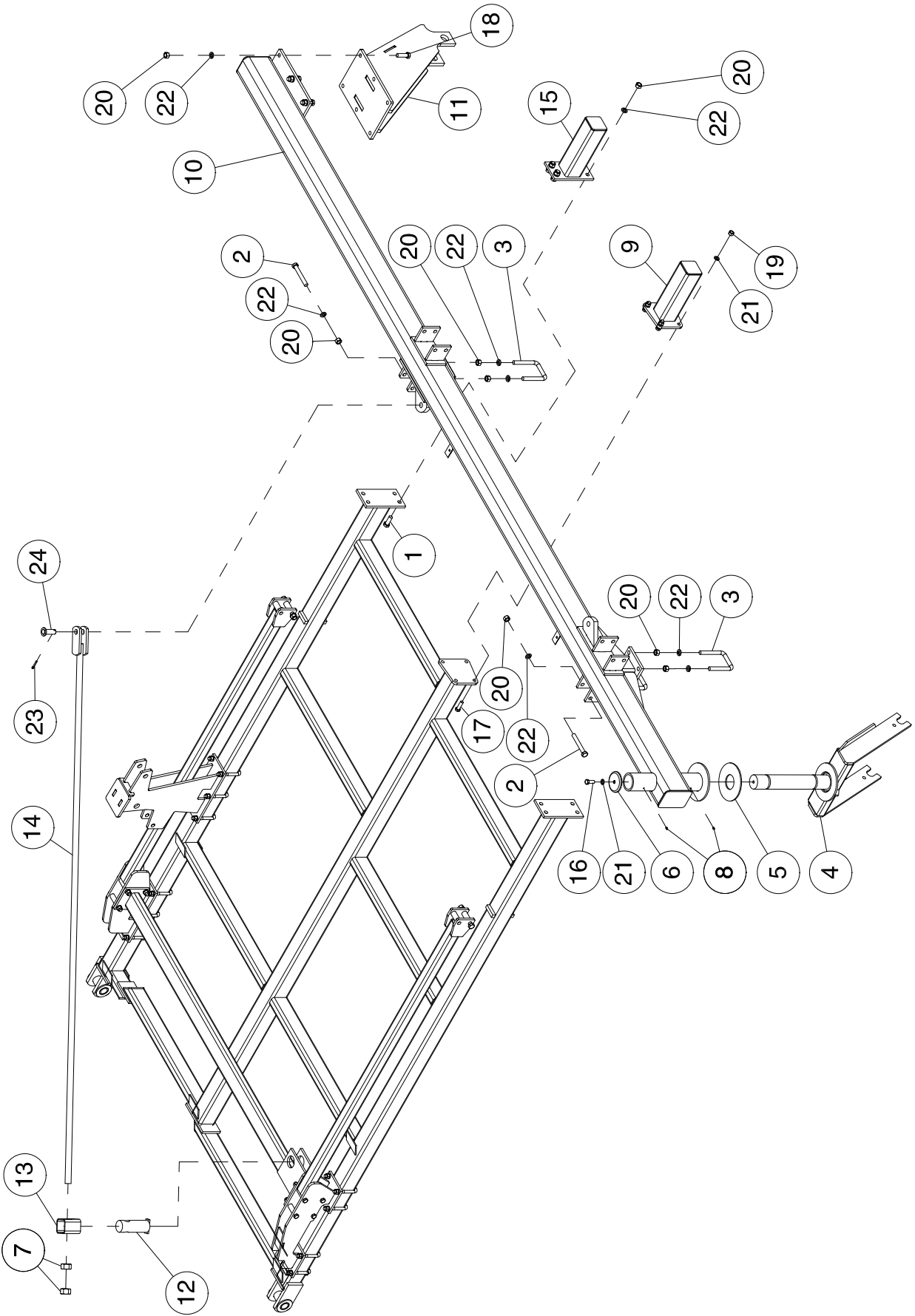

Wing Frame Depth Beams - 25 & 31 Ft

Item	Part No.	Description	Qty
1	C-695	Hex Bolt - 3/4 x 2 Lg.....	4
2	C-3919	Hex Bolt - 3/4 x 5 1/2 Lg.....	4
3	C-5561	U-Bolt - 3/4 x 4 x 5-9/16.....	4
4	C18657	Fork - Outer Castor	1
5	C18662	Wear Plate.....	1
6	C18782	Cap - 3 Dia.....	1
7	P61D20	Hex Nut - 1 1/4.....	2
8	S-752	Grease Zerk - 1/4.....	2
9	S42862	Extension Stub - 14 1/4 Lg - 31 ft.....	1
10	S42918	Left Wing Depth Tube - 31 ft - Prior to Sept. 2012	1
	S51009	Left Wing Depth Tube - 31 ft.....	1
	S42919	Right Wing Depth Tube - 31 ft - Prior to Sept. 2012	1
	S51011	Right Wing Depth Tube - 31 ft.....	1
10A	S42982	Wing Depth Tube (Left and Right for 25ft) 1 per wing - Prior to Sept. 2012	2
	S51015	Wing Depth Tube (Left and Right for 25ft) 1 per wing.....	2
11	S47084	Rear Axle - Wing - 25 3/8 Lg - Prior to Sept. 2012	1
	S51025	Rear Axle - Wing - 27 3/8 Lg.....	1
12	S44983	Outer Wing Lift Pivot - Lg.....	1
13	S44984	Spacer Tube.....	1
14	S44985	Tie Rod - 97 Lg - 25 ft.....	1
	S44991	Tie Rod - 115 1/2 Lg - 31 ft.....	1
15	S44993	Extension Stub Rear - 12 inch spacing.....	1
16	W-497	Hex Bolt - 5/8 x 1-1/2 Lg.....	1
17	W-499	Hex Bolt - 5/8 x 2 Lg.....	4
18	W-509	Hex Bolt - 3/4 x 2-1/2 Lg.....	6
19	W-517	Hex Nut - 5/8.....	4
20	W-518	Hex Nut - 3/4.....	18
21	W-526	Lockwasher - 5/8.....	5
22	W-527	Lockwasher - 3/4.....	18
23	W-535	Cotter Pin - 1/4 x 1 1/2 Lg.....	1
24	W-558	Pin - 1 Dia x 2-1/4 UL.....	1

Prior to Sept. 2012

31' Prior to serial # C231132012

Frames & Hitching Wing Lift Truss - 41 Ft to 51 Ft

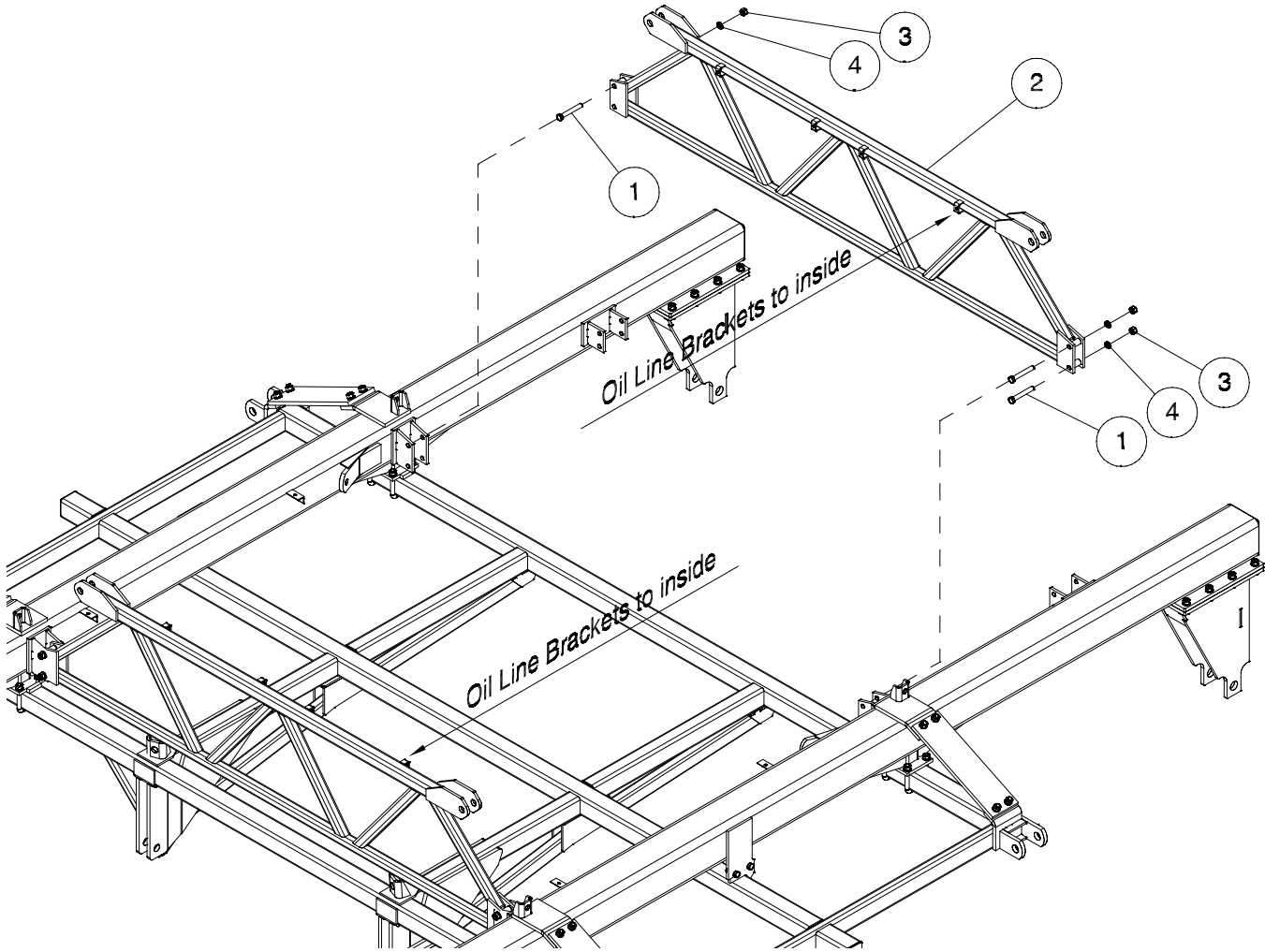

Item	Part No.	Description	Qty
1	S-1191	Hex Bolt - 3/4 x 5 Lg.....	8
2	S42703	Wing Lift Truss - Front and Back.....	2
3	W-518	Hex Nut - 3/4.....	8
4	W-527	Lockwasher - 3/4.....	8

Frames & Hitching Wing Lift Truss - 61 Ft & 71 Ft

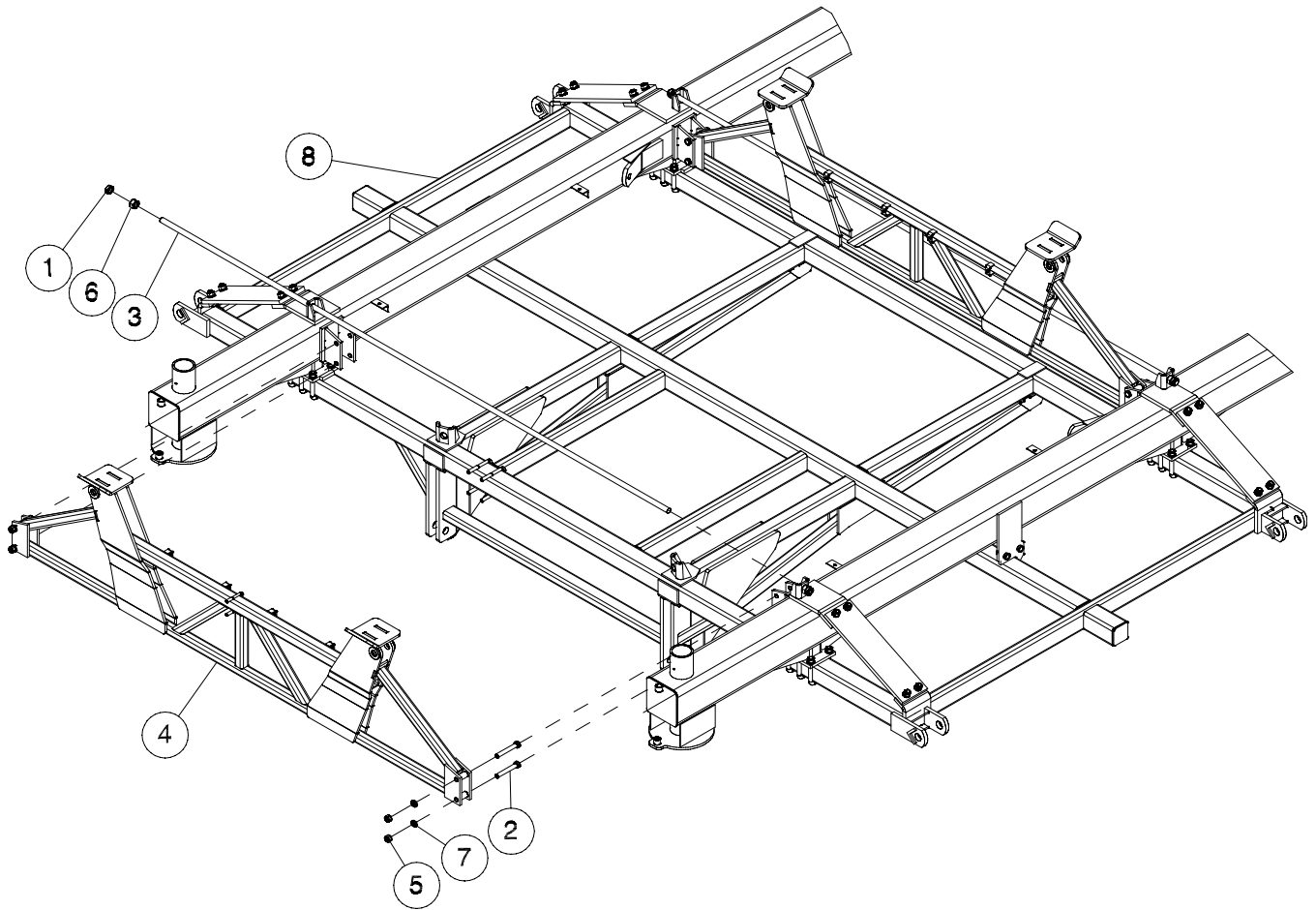

Item	Part No.	Description	Qty
1	S-711	Hex Jam Nut - 1	4
2	S-1191	Hex Bolt - 3/4 x 5 Lg.....	8
3	S44361	Truss Rod - 1 Dia x 132 Lg	2
4	S44465	Main Wing Lift Truss - 61 & 71	2
5	W-518	Hex Nut - 3/4	69
6	W-520	Hex Nut - 1	4
7	W-527	Lockwasher - 3/4.....	68
8	S49800	Main Frame	1

Frames & Hitching Wing Frame and Truss - 41 Ft to 51 Ft

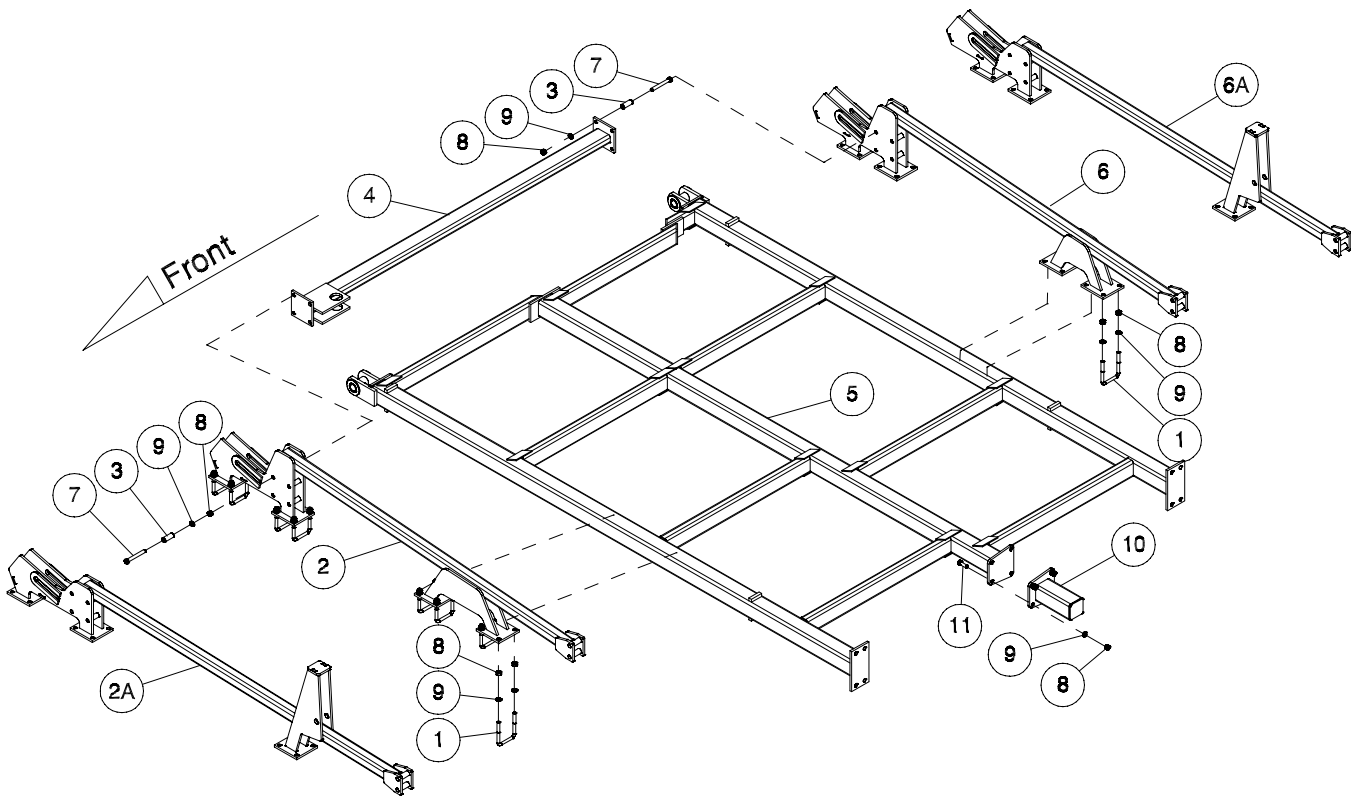

Item	Part No.	Description	Qty
1	C-219	U-Bolt - 5/8 x 4 x 5 9/16	32
2	S42956	Winglift - Front Truss - 41Ft.....	2
2A	S47061	Winglift - Front Truss - 51Ft.....	2
3	S42707	Spacer Bushing - 1 OD x 0.688 ID x 2 15/32 Lg.....	16
4	S44981	Support Beam - 88 1/4 Lg.....	2
5	S49804	Wing Frame - 41Ft & 51Ft.....	2
6	S42957	Winglift - Rear Truss - 41Ft.....	2
6A	S47064	Winglift - Rear Truss - 51Ft.....	2
7	W-506	Hex Bolt - 5/8 x 5 Lg.....	16
8	W-517	Hex Nut - 5/8.....	88
9	W-526	Lockwasher - 5/8.....	88
10	S42861	Extension Stub -11 1/4 Lg - 41ft 12" Spacing.....	2
	S42862	Extension Stub - 14 1/4 Lg - 41ft 10" Spacing	2
11	W-498	Hex Bolt - 5/8 x 1 3/4 Lg.....	8

Frames & Hitching Wing Frame Depth Beam - 41 Ft to 51 Ft

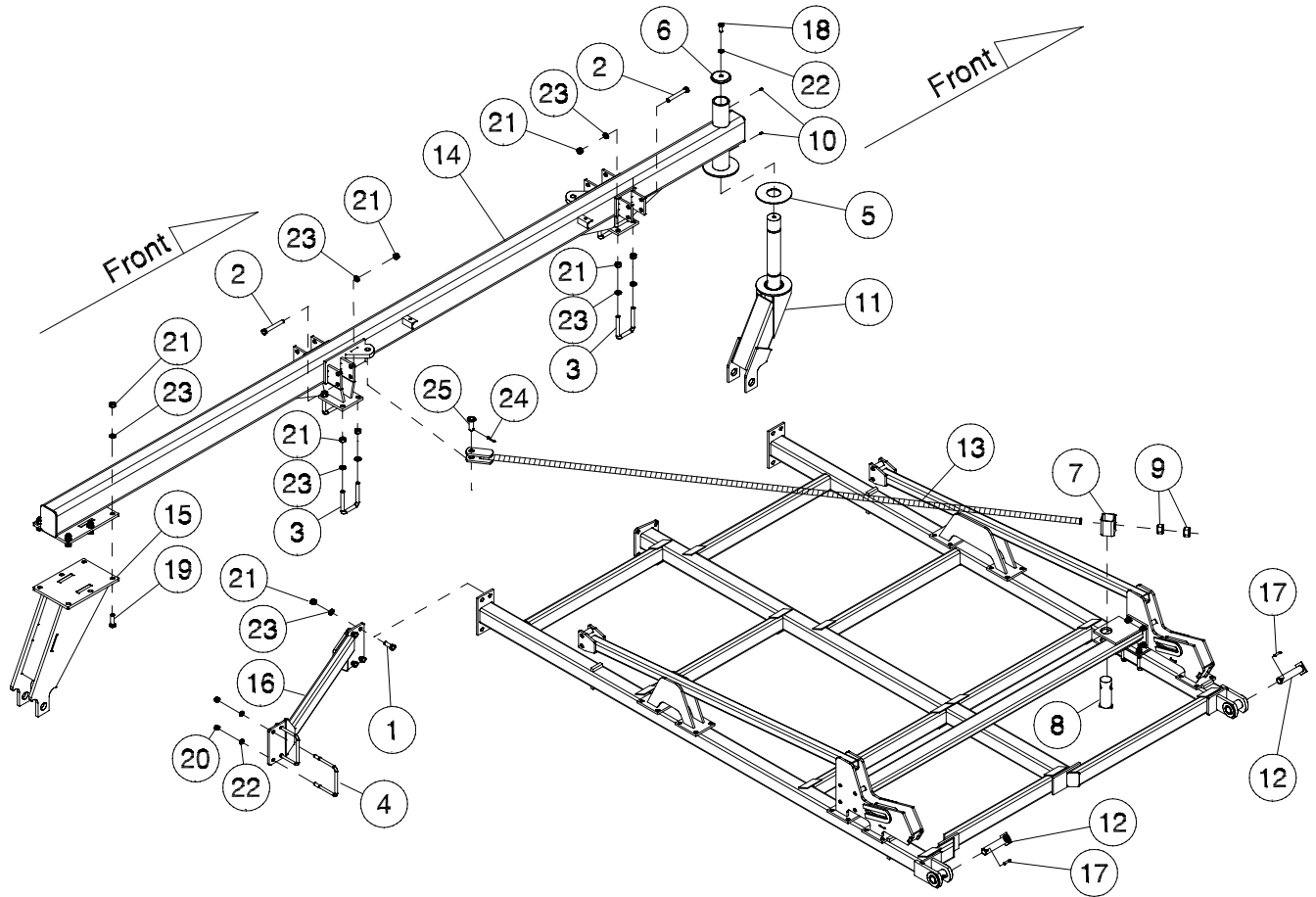

Item	Part No.	Description	Qty
1	C-695	Hex Bolt - 3/4 x 2 Lg.....	8
2	C-3919	Hex Bolt - 3/4 x 5 1/2 Lg.....	8
3	C-5561	U-Bolt - 3/4 x 4 x 5 9/16.....	8
4	N33342	U-Bolt - 5/8 x 7 x 6 1/2.....	4
5	C18662	Wear Plate - 3 1/8 ID x 8 OD.....	2
6	C18782	Cap - 3 Dia.....	2
7	S44984	Spacer Tube.....	2
8	S47655	Tie Rod Pin.....	2
9	P61D20	Hex Nut - 1 1/4.....	4
10	S-752	Straight Grease Zerk - 1/4.....	4
11	S45720	Offset Castor - 3/4 Side Plates - Dual Wheel Option.....	2
12	S42725	Hinge Pin - 1 1/2 Dia x 6 3/8 UL.....	4
13	S44991	Tie Rod - 115 1/2 - 41Ft.....	2
	S47067	Tie Rod - 121 - 51Ft.....	2
14	S42918	Depth Tube - Left Wing - (5 1/8) - 41Ft - Prior to Sept. 2012.....	1
	S51009	Depth Tube - Left Wing - 3 Lift (8 1/8) - 41Ft.....	1
	S42919	Depth Tube - Right Wing - (5 1/8) - 41Ft - Prior to Sept. 2012.....	1
	S51011	Depth Tube - Right Wing - 3 Lift (8 1/8) - 41Ft.....	1
14A	S42982	Depth Tube - Right & Left Wing - (5 1/8) - 51Ft - Prior to Sept. 2012.....	2
	S51015	Depth Tube - Right & Left Wing - 3 Lift (8 1/8) - 51Ft.....	2
15	S47084	Rear Axle - Wing - 25 3/8 Lg - Prior to Sept. 2012.....	2
	S51025	Rear Axle - Wing - 27 3/8 Lg.....	2
16	S42977	Wing Depth Beam Brace Left - 41Ft.....	1
	S42976	Wing Depth Beam Brace Right - 41Ft.....	1
17	T-5245	Spiral Pin - 3/8 x 2 1/2 Lg.....	4
18	W-497	Hex Bolt - 5/8 x 1 1/2 Lg.....	2
19	W-509	Hex Bolt - 3/4 x 2 1/2 Lg.....	12
20	W-517	Hex Nut - 5/8.....	8
21	W-518	Hex Nut - 3/4.....	44
22	W-526	Lockwasher - 5/8.....	10
23	W-527	Lockwasher - 3/4.....	44
24	W-535	Cotter Pin - 1/4 x 1 1/2 Lg.....	2
25	W-558	Pin - 1 Dia x 2 1/4 UL.....	2

Frames & Hitching 51 Ft Flip Wing

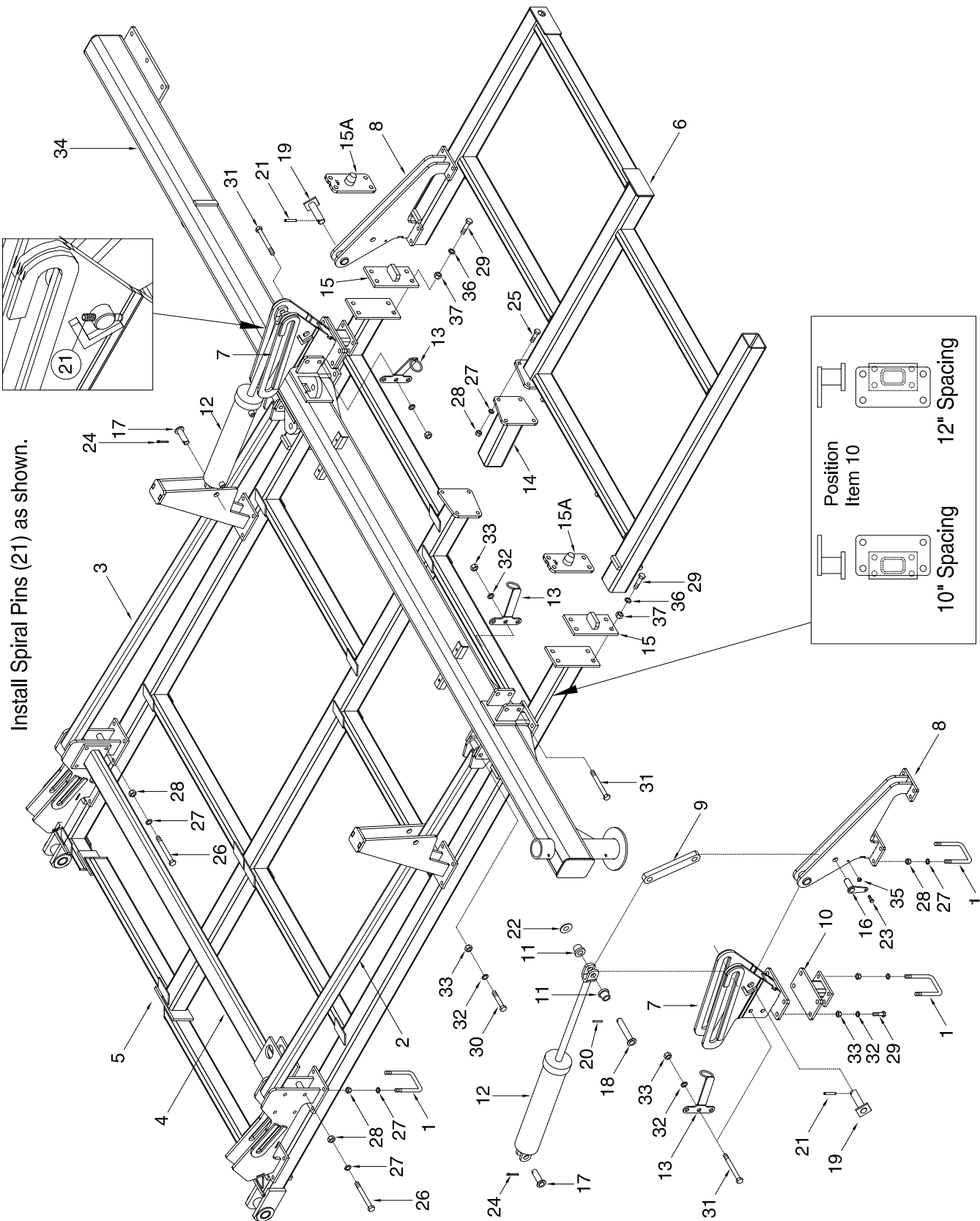

Frames & Hitching - 51 Ft Flip Wing

Item	Part No.	Description	Qty
1	C-219	U-Bolt - 5/8 x 4 x 5 9/16	48
2	S47061	Winglift - Front Truss - 51Ft.....	2
3	S47064	Winglift - Rear Truss - 51Ft	2
4	S44981	Support Beam - 88 1/4 Lg - 51Ft	2
5	S42914	Wing Frame - 51Ft	2
6	S49841	Flip Wing	2
7	S45759	Flip Hinge Bracket.....	4
8	S45771	Outer Flip Hinge.....	4
9	N33796	Wing Lift Link - 1 x 2 x 11 1/2 Lg - 1 Dia holes - 9 1/4 Hole Centers	4
10	S47060	Outer Hinge Brace	4
11	N33797	Wing Lift Roller.....	8
12	*****	Cylinder - See Hydraulic Section	4
13	S47749	Hose Holder	4
14	S49842	Extension Stub - 12 13/16 Lg	2
15	S47059	Frame Stop - Prior to 2015.....	4
15A	S53925	Frame Stop - 2015.....	4
16	S49850	Pin - 1 x 2 13/32 UL	4
17	W-1628	Pin - 1 x 3 3/4 UL	4
18	S13261	Pin - 1 x 5 5/8 UL	4
19	S45796	Pin - 1 1/4 x 4 1/16 UL	4
20	D-5244	Spiral Pin - 1/4 x 2 Lg.....	4
21	T-5245	Spiral Pin - 3/8 x 2 1/2 Lg.....	4
22	D-5498	Washer - 1 1/16 ID x 2 OD x 11 Ga.....	4
23	W-187	Hex Bolt - 3/8 x 1 1/4	4
24	W-535	Cotter Pin - 1/4 x 1 1/2 Lg	4
25	W-498	Hex Bolt - 5/8 x 1 3/4 Lg.....	8
26	W-506	Hex Bolt - 5/8 x 5 Lg.....	16
27	W-526	Lockwasher - 5/8.....	120
28	W-517	Hex Nut - 5/8.....	120
29	C-695	Hex Bolt - 3/4 x 2 Lg.....	32
30	C-3919	Hex Bolt - 3/4 x 5 1/2 Lg.....	8
31	D-5558	Hex Bolt - 3/4 x 6 Lg.....	8
32	W-527	Lockwasher - 3/4.....	32
33	W-518	Hex Nut - 3/4.....	32
34	S42982	Depth Tube - Outer Wing - (5 1/8) - Prior to Sept. 2012	2
	S51015	Depth Tube - Outer Wing - 3 Lift (8 1/8).....	2
35	M-3388	Hex Lock Nut - 3/8	4
36	W-476	Flat Washer - 3/4.....	16
37	D12942	Lock Nut - 3/4.....	16

Prior to Sept. 2012

51' Prior to serial # C251132035

Frames & Hitching Wing Lift - 41 Ft to 51 Ft

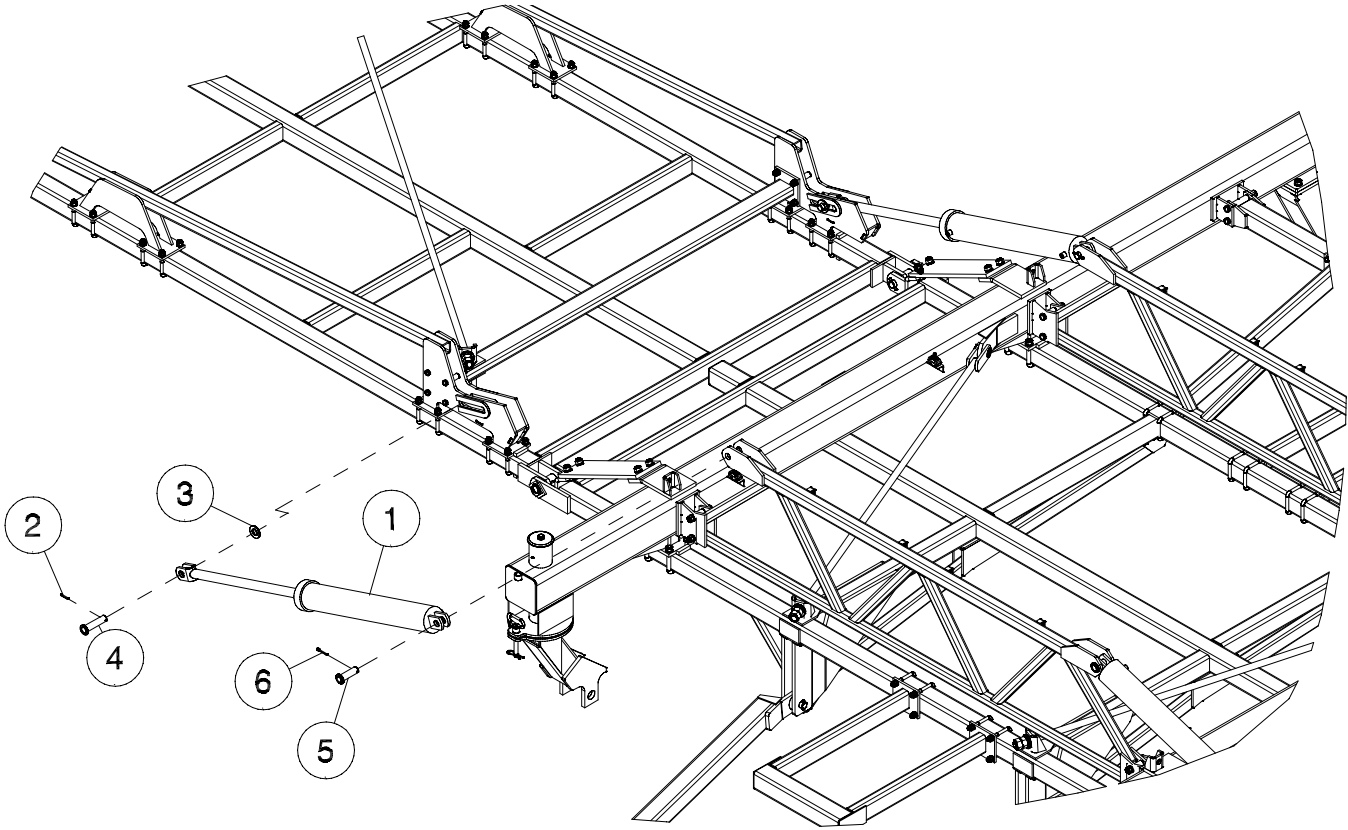

Item	Part No.	Description	Qty
1	C34442	Hyd Cylinder - 4 1/2 x 30.....	4
2	D-5244	Spiral Pin - 1/4 X 2.....	2
3	N13962	Washer - 1 9/32 ID x 2 1/2 OD x 1/4 Thick.....	2
4	N28988	Pin - 1 1/4 x 4 3/4.....	2
5	S39543	Pin - 1 1/4 X 3 5/8.....	2
6	W-4181	Cotter Pin - 1/4 x 2 Lg.....	2
<p>Note: See “51 Ft Flip Wing” on page 1-24 for 51 foot flip wing.</p>			

Frames & Hitching Inner Wing Frame and Truss - 5 Frame

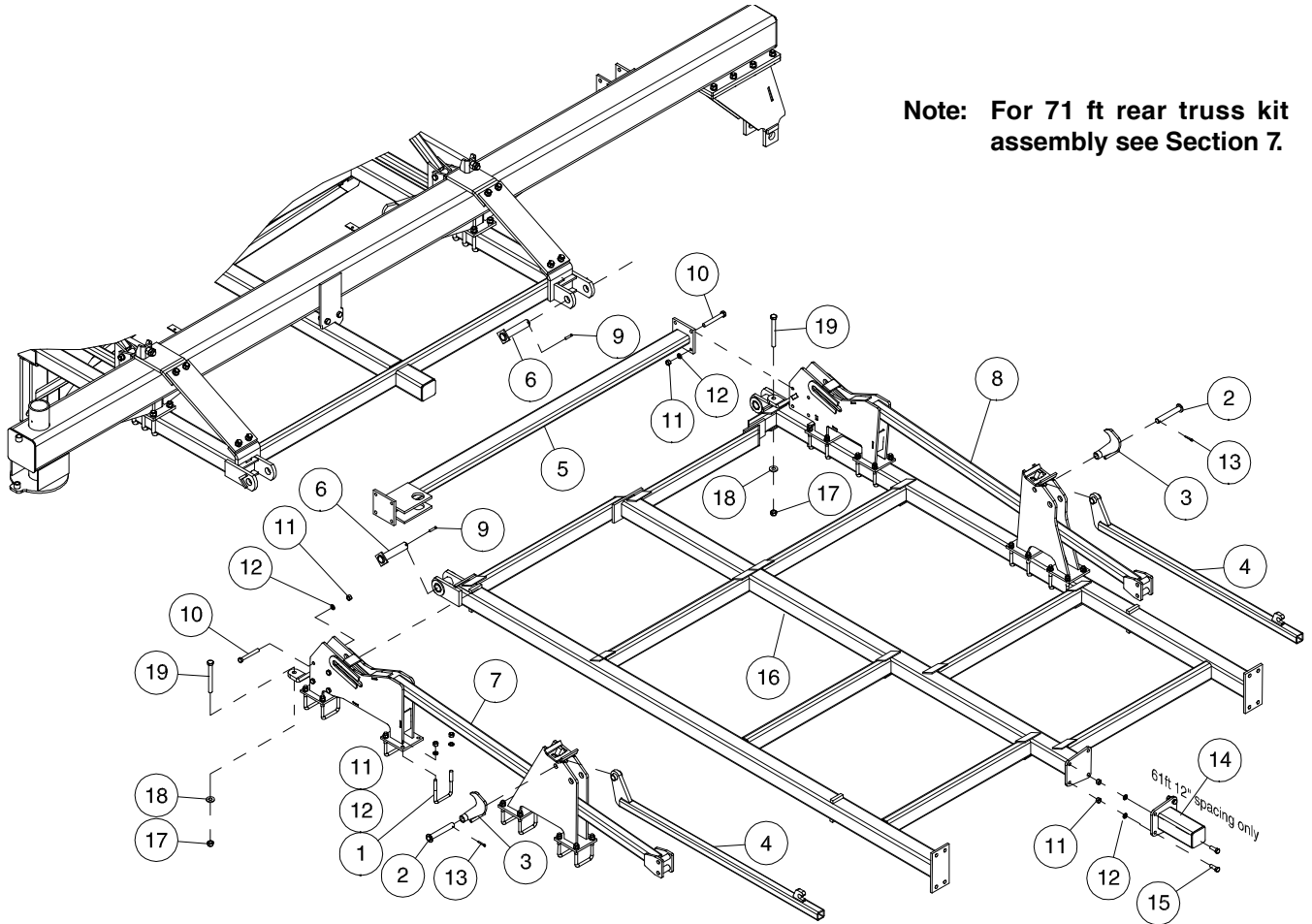

Note: For 71 ft rear truss kit assembly see Section 7.

Item	Part No.	Description	Qty
1	C-219	U-Bolt - 5/8 x 4 x 5 9/16	32
2	C26844	Pin - 1 Dia x 6 1/8 UL.....	4
3	S39443	Transport Gravity Lock.....	4
4	S55945	Brace - Outer Wing Lift - 80 to 90 ft - 2015 to present	2
5	S44981	Support Beam - 88 1/4 Lg.....	2
6	S42725	Hinge Pin - 1 1/2 Dia x 6 3/8 UL	2
7	S55915	Inner Wing Lift Truss - Front - 61 ft (Shown) - 2015.....	2
	S55920	Inner Wing Lift Truss - Front - 71 ft to 90 Ft - 2015.....	2
8	S55905	Inner Wing Lift Truss - Rear - 61 ft (Shown) - 2015.....	2
	S55925	Inner Wing Lift Truss - Rear - 71 ft to 90 Ft - 2015	2
9	T-5245	Spiral Pin - 3/8 x 2 1/2 Lg	4
10	W-506	Hex Bolt - 5/8 x 5 Lg.....	16
11	W-517	Hex Nut - 5/8.....	88
12	W-526	Lock Washer - 5/8	88
13	W-535	Cotter Pin - 1/4	4
14	S42861	Extension Stub - 11 1/4 Lg - 12 inch spacing only - 61 ft	2
15	W-498	Hex Bolt - 5/8 X 1 3/4 Lg.....	8
16	S49804	Wing Frame - 61 Ft	2
	S49811	Wing Frame - 71 Ft to 90 Ft	2
17	D-5273	Lock Nut - 3/4.....	2
18	W-476	Washer - 13/16 ID x 1 1/2 OD x 0.134 Thick	2
19	C26697	Hex Bolt - 3/4 x 6 1/2 Lg.....	2

Frames & Hitching Inner Wing Frame - 61 Ft & 71 Ft

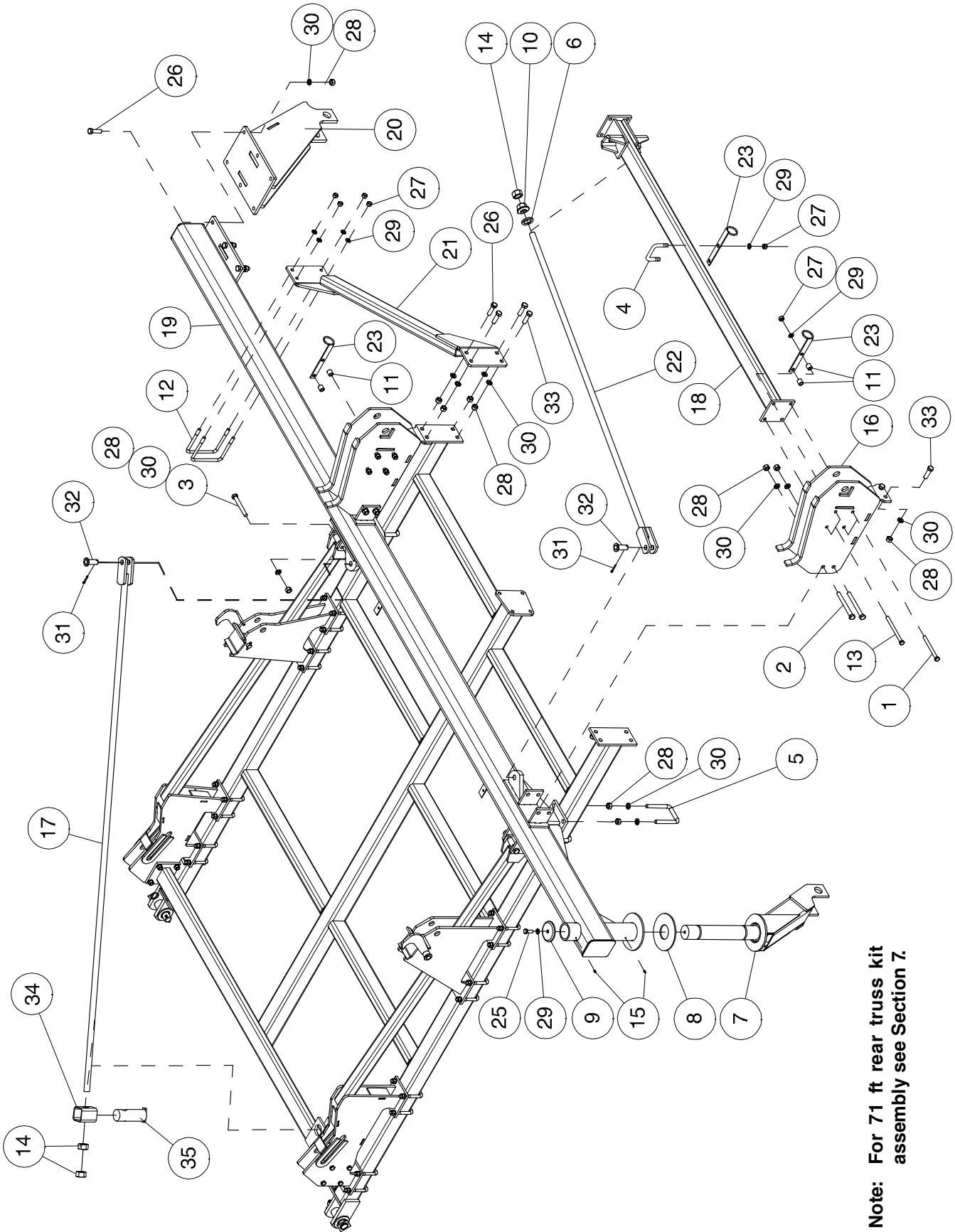

Note: For 71 ft rear truss kit assembly see Section 7.

Frames & Hitching - Inner Wing Frame 61 Ft & 71 Ft

Item	Part No.	Description	Qty
1	C-508	Hex Bolt - 5/8 x 6 1/2 Lg.....	8
2	C-3917	Hex Bolt - 3/4 x 7 Lg	8
3	C-3919	Hex Bolt - 3/4 x 5 1/2 Lg.....	8
4	C-4569	U-Bolt - 5/8 x 4 1/32 x 3 1/4	2
5	C-5561	U-Bolt - 3/4 x 4 x 5 9/16	8
6	C15767	Spherical Washer - 2 1/2 Dia	4
7	S45720	Offset Castor - 3/4 Side Plates.....	2
8	C18662	Wear Plate.....	2
9	C18782	Cap - 3 Dia.....	2
10	C31361	Spherical Nut - 1 1/4	2
11	H27972	Bushing - 1 OD x .640 ID	8
12	N33342	U-Bolt - 5/8 x 7 x 6 1/2	4
13	P1C10120	Hex Bolt - 5/8 x 7 1/2 Lg.....	8
14	P61D20	Hex Nut - 1 1/4 - 61 ft & 71 ft.....	6
15	S-752	Grease Fitting - 1/4	4
16	S42802	Outer Winglift Hinge - Front.....	4
17	S49815	Tie Rod - 127 UL - 61 ft.....	2
	S45792	Tie Rod - 151 UL - 71 ft.....	2
18	S42849	Support Beam - 86 23/32 Lg.....	2
19	S42918	Depth Tube - Left Wing - (5 1/8) - Prior to Sept. 2012	1
	S51009	Depth Tube - Left Wing - 3 Lift (8 1/8).....	1
	S42919	Depth Tube - Right Wing - (5 1/8) - Prior to Sept. 2012	1
	S51011	Depth Tube - Right Wing - 3 Lift (8 1/8)	1
20	S47084	Rear Axle - Wing - 25 3/8 Lg - Prior to Sept. 2012	2
	S51025	Rear Axle - Wing - 27 3/8 Lg	2
21	S42977	Wing Depth Beam Brace Left - 61 ft & 71 ft	1
	S42976	Wing Depth Beam Brace Right - 61 ft & 71 ft.....	1
22	S42987	Tie Rod - 80.5 UL.....	2
23	S44313	Hose Holder	6
24	S44367	Spacer Bushing - 1 OD x .688 ID - 3 31/32 Lg	16
25	W-497	Hex Bolt - 5/8 x 1 1/2 Lg.....	2
26	W-509	Hex Bolt - 3/4 x 2 1/2 Lg.....	20
27	W-517	Hex Nut - 5/8.....	28
28	W-518	Hex Nut - 3/4.....	52
29	W-526	Lockwasher - 5/8.....	30
30	W-527	Lockwasher - 3/4.....	52
31	W-535	Cotter Pin - 1/4 x 1 1/2 Lg	4
32	W-558	Pin - 1 Dia x 2 1/4 UL.....	4
33	C-695	Hex Bolt - 3/4 x 2 Lg.....	4
34	S44984	Spacer Tube	2
35	S47655	Tie Rod Pin	2

Prior to Sept. 2012

61' **Prior to serial # C261132067**

71' **Prior to serial # C271132031**

Frames & Hitching Inner Wing Frame - 80, 86 & 90 Ft

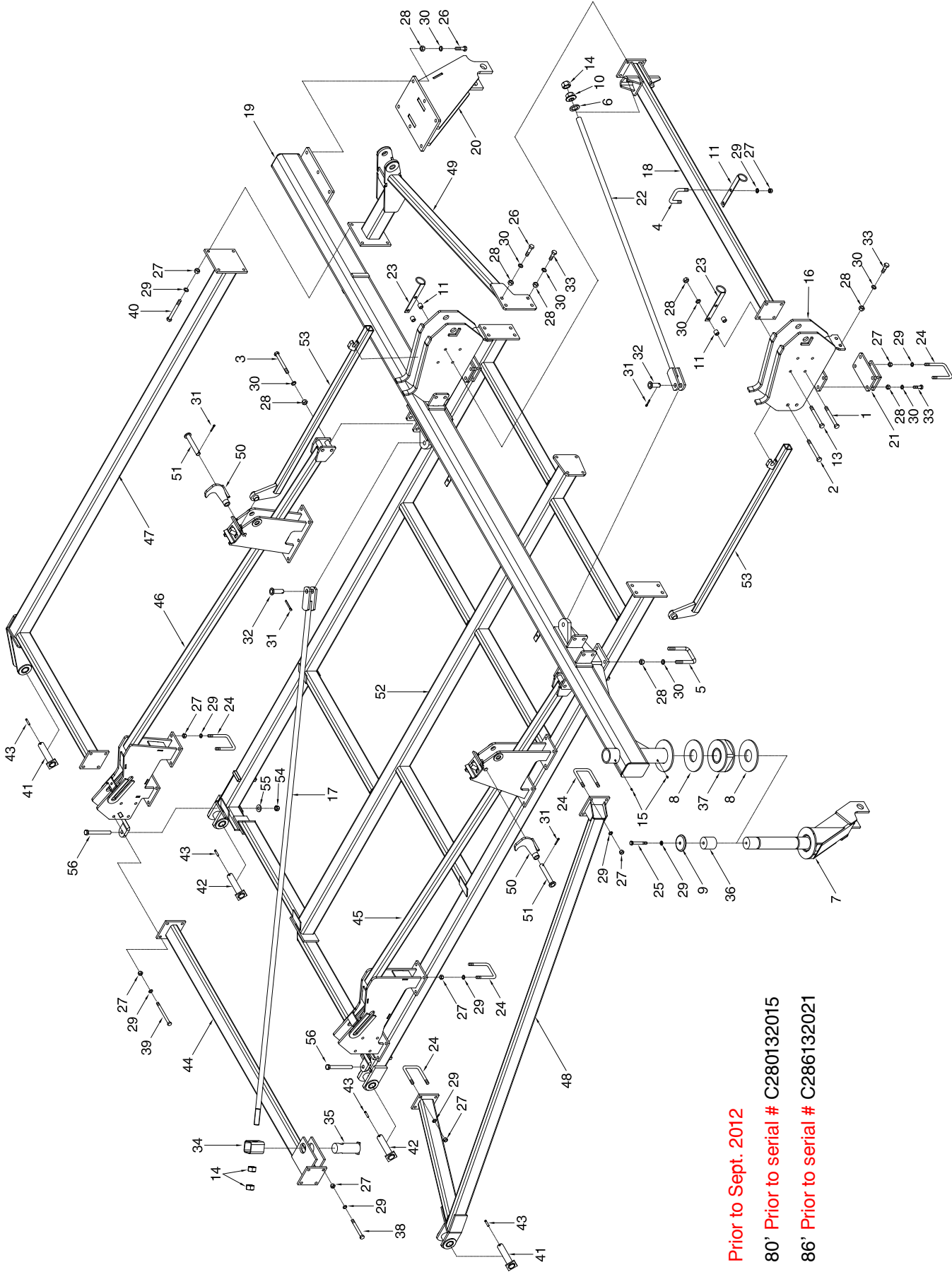

Prior to Sept. 2012
80' Prior to serial # C280132015
86' Prior to serial # C286132021

Frames & Hitching - Inner Wing Frame - 80, 86 & 90 Ft

Item	Part No.	Description	Qty
1	C-508	Hex Bolt - 5/8 x 6 1/2 Lg.....	8
2	C-3917	Hex Bolt - 3/4 x 7 Lg	8
3	C-3919	Hex Bolt - 3/4 x 5 1/2 Lg.....	8
4	C-4569	U-Bolt - 5/8 x 4 1/32 x 3 1/4	2
5	C-5561	U-Bolt - 3/4 x 4 x 5 9/16	8
6	C15767	Spherical Washer - 2 1/2 Dia	4
7	S45720	Offset Castor - 3/4 Side Plates.....	2
8	C18662	Wear Plate.....	2
9	C18782	Cap - 3 Dia.....	2
10	C31361	Spherical Nut - 1 1/4	2
11	H27972	Bushing - 1 OD x 0.640 ID	8
12	N33342	U-Bolt - 5/8 x 7 x 6 1/2	4
13	P1C10120	Hex Bolt - 5/8 x 7 1/2 Lg.....	8
14	P61D20	Hex Nut - 1 1/4.....	6
15	S-752	Grease Fitting - 1/4	4
16	S42802	Outer Winglift Hinge - Front.....	4
17	S45792	Tie Rod - 151 UL - 80 ft & 86 ft.....	2
18	S42849	Support Beam - 86 23/32 Lg.....	2
19	S42918	Depth Tube - Left Wing - (5 1/8) - Prior to Sept. 2012	1
	S51009	Depth Tube - Left Wing - 3 Lift (8 1/8)	1
	S42919	Depth Tube - Right Wing - (5 1/8) - Prior to Sept. 2012	1
	S51011	Depth Tube - Right Wing - 3 Lift (8 1/8)	1
20	S47084	Rear Axle Wing Depth Beam - 25 3/8 Lg - Prior to Sept. 2012	2
	S51025	Rear Axle Wing Depth Beam - 27 3/8 Lg	2
21	S45926	Outer Hinge Brace	4
22	S42987	Tie Rod - 80.5 UL.....	2
23	S44313	Hose Holder	6
24	C-219	U-Bolt - 5/8 x 4 x 5 9/16	42
25	W-497	Hex Bolt - 5/8 x 1 1/2 Lg.....	2
	C-852	Hex Bolt - 5/8 x 4 1/2 Lg - used with Castor Plug Item 36.....	2
26	W-509	Hex Bolt - 3/4 x 2 1/2 Lg.....	20
27	W-517	Hex Nut - 5/8.....	28
28	W-518	Hex Nut - 3/4	52
29	W-526	Lockwasher - 5/8.....	30
30	W-527	Lockwasher - 3/4.....	52
31	W-535	Cotter Pin - 1/4 x 1 1/2 Lg	4
32	W-558	Pin - 1 Dia x 2 1/4 UL.....	4
33	C-695	Hex Bolt - 3/4 x 2 Lg.....	4
34	S44984	Spacer Tube - 80 Ft & 86 Ft	2
35	S47655	Tie Rod Pin - 80 Ft & 86 Ft	2
36	S42434	Castor Plug - 3 x 3 Lg - Prior to Sept. 2012	2
37	S42440	Castor Spacer - 2 3/4 - Prior to Sept. 2012	2
38	W-506	Hex Bolt - 5/8 x 5 Lg.....	8
39	S-1344	Hex Bolt - 5/8 x 5 1/2 Lg.....	8
40	J12181	Hex Bolt - 5/8 x 7 Lg.....	8
41	S47518	Pin - 1 1/2 Dia x 5 5/8 UL.....	4
42	S42725	Pin - 1 1/2 Dia x 6 3/8 UL.....	4
43	T-5245	Spiral Pin - 3/8 x 2 1/2.....	8
44	S44981	Support Beam - 88 1/4 Lg - 80 Ft to 90 Ft	2
45	S55920	Inner Wing Lift Truss - Front - 71 ft to 90 Ft - 2015	2
46	S55925	Inner Wing Lift Truss - Rear - 71 ft to 90 Ft - 2015	2
47	S45936	Rear Truss - Inner to Main - Left	1
	S47520	Rear Truss - Inner to Main - Right.....	1
48	S45750	Wing Front Hitch Brace	2
49	S45945	Rear Truss - Inner to Outer - Left.....	1
	S47521	Rear Truss - Inner to Outer - Right.....	1
50	S39443	Transport Gravity Lock.....	4
51	C26844	Pin - 1 Dia x 6 1/8 UL.....	4
52	S49811	Wing Frame - Inner	2
53	S55945	Brace - Outer Wing Lift - 2015	2
54	D-5273	Lock Nut - 3/4.....	2
55	W-476	Washer - 13/16 ID x 1 1/2 OD x 0.134 Thick	2
56	C26697	Hex Bolt - 3/4 x 6 1/2 Lg.....	2

Frames & Hitching Outer Wing - 61 Ft

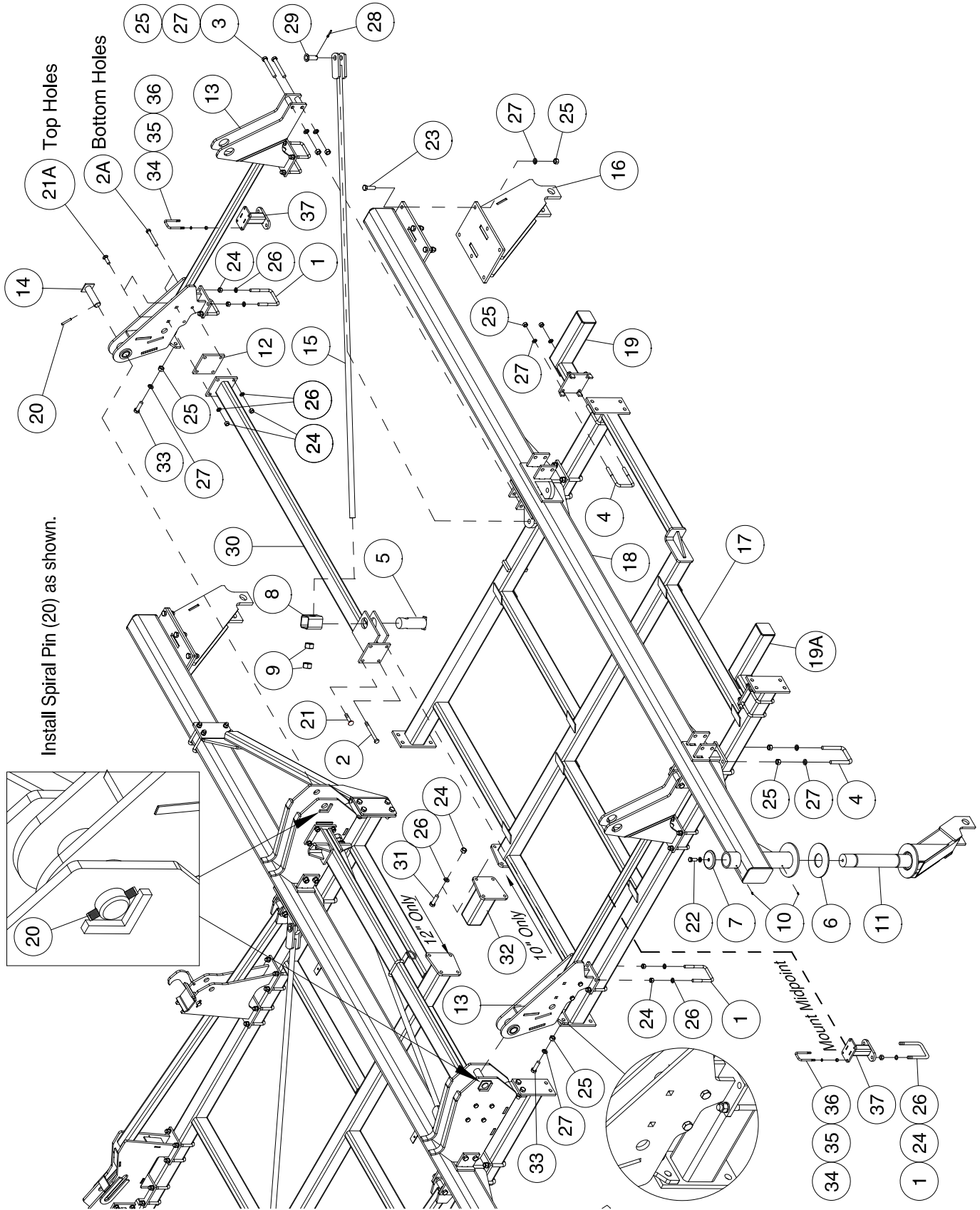

Frames & Hitching - Outer Wing - 61 Ft

Item	Part No.	Description	Qty
1	C-219	U-Bolt - 5/8 x 4 x 5 9/16	20
2	C-852	Hex Bolt - 5/8 x 4 1/2 Lg.....	8
2A	S-1344	Hex Bolt - 5/8 x 5 1/2 Lg.....	4
3	C-3919	Hex Bolt - 3/4 x 5 1/2 Lg.....	8
4	C-5561	U-Bolt - 3/4 x 4 x 5 9/16	12
5	S47655	Tie Rod Pin	2
6	C18662	Wear Plate.....	2
7	C18782	Cap - 3 Dia.....	2
8	S44984	Spacer Tube	2
9	P61D20	Hex Nut - 1 1/4.....	4
10	S-752	Grease Zerk - 1/4.....	4
11	S45720	Offset Castor - 3/4 Side Plates - Dual Wheel	2
12	F10542	Spacer Plate	2
13	S42812	Outer Wing Lift Truss.....	4
14	S42822	Pin - 1 1/2 x 5 1/8 UL	4
15	S49819	Tie Rod - 105 UL.....	2
16	S47084	Rear Axle Wing Depth Beam - 25 3/8 Lg - Prior to Sept. 2012	
	S51025	Rear Axle Wing Depth Beam - 27 3/8 Lg	2
17	S42927	Outer Wing Frame - 61 ft - Prior to Sept. 2012	2
	S50470	Outer Wing Frame - 61 ft.....	2
18	S42982	Outer Wing Depth Tube - (5 1/8) - Prior to Sept. 2012	2
	S51015	Outer Wing Depth Tube - 3 Lift (8 1/8)	2
19	S49853	HD Extention Stub - 8 offset - 12 inch spacing only - Prior to Sept. 2012 (Uses C-219 U-Bolt) ..	2
	S51024	HD Extention Stub - 8 offset - 12 inch spacing only	2
19A	S44314	HD Extention Stub - 5 7/8 offset - 10 inch spacing only - Prior to Sept. 2012	2
	S51022	HD Extention Stub - 5 7/8 offset - 10 inch spacing only	2
20	T-5245	Spiral Pin - 3/8 x 2 1/2 Lg	4
21	T-5268	Carriage Bolt - 5/8 x 2 Lg	8
21A	N33594	Carriage Bolt - 5/8 x 2 1/4 Lg	4
22	W-497	Hex Bolt - 5/8 x 1 1/2 Lg.....	2
23	W-509	Hex Bolt - 3/4 x 2 1/2 Lg.....	14
24	W-517	Hex Nut - 5/8.....	56
25	W-518	Hex Nut - 3/4.....	52
26	W-526	Lockwasher - 5/8.....	56
27	W-527	Lockwasher - 3/4.....	52
28	W-535	Cotter Pin - 1/4 x 1 1/2 Lg	2
29	W-558	Pin - 1 Dia x 2 1/4 UL.....	2
30	S44981	Support Beam - 88 1/4 Lg.....	2
31	W-498	Hex Bolt - 5/8 X 1 3/4 Lg - 10 inch spacing only	4
32	S42861	Extention Stub - 11 1/4 Lg - 10 inch spacing only	2
33	C-695	Hex Bolt - 3/4 x 2 Lg.....	6
34	N15097	U-Bolt - 3/8 x 2 x 5 UL.....	8
35	W-514	Hex Nut - 3/8.....	16
36	W-523	Lockwasher - 3/8.....	16
37	S64080	Truss Support	4
	S64076	Kit Truss Support Outer Wing (Includes items 34, 35, 36, 37 and required qty of 1, 24, 26)	
		Prior to Sept. 2012	
		61' Prior to serial # C261132067	

Outer Wing - 71 Ft

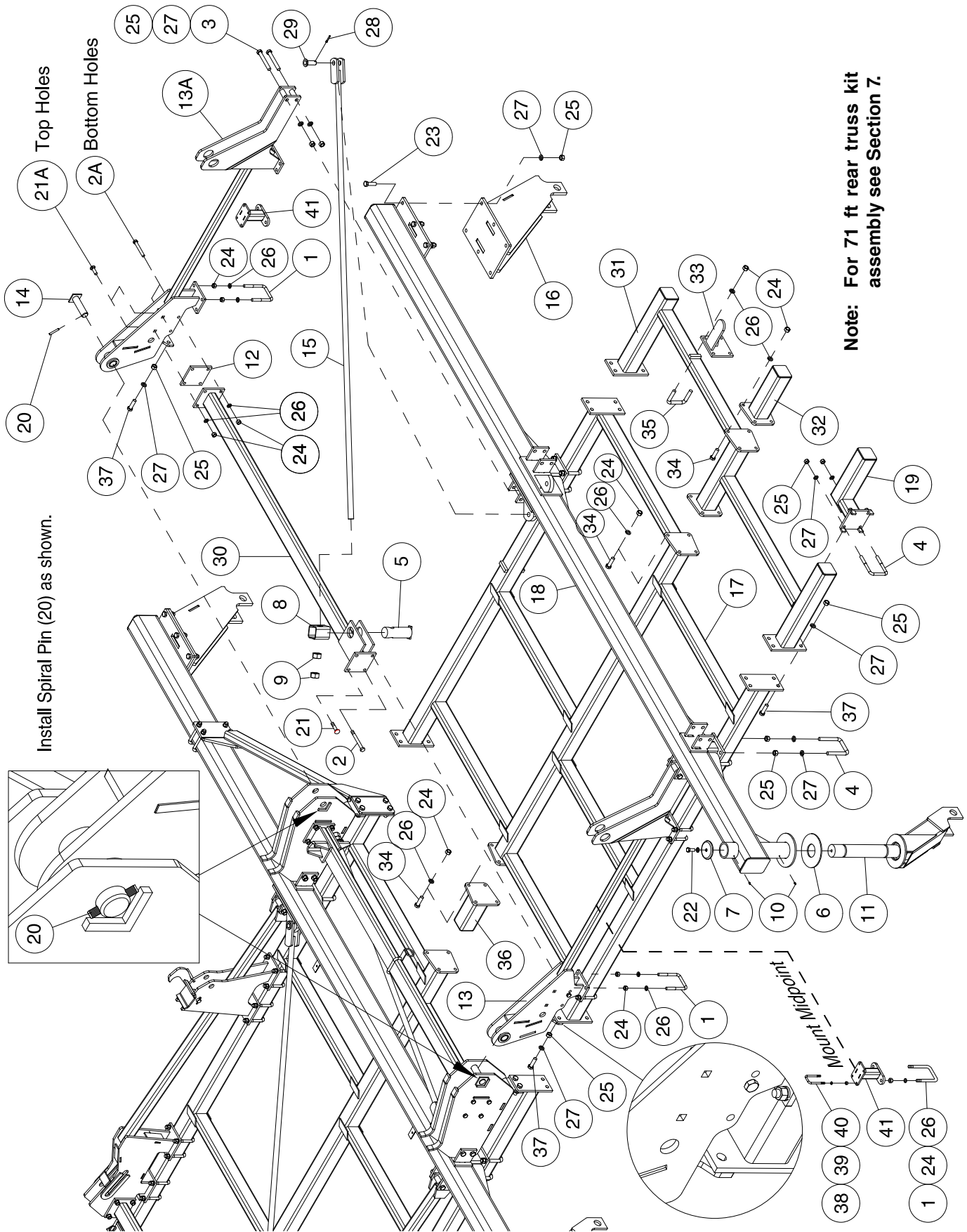

Note: For 71 ft rear truss kit assembly see Section 7.

Outer Wing - 71 Ft

Item	Part No.	Description	Qty
1	C-219	U-Bolt - 5/8 x 4 x 5 9/16	20
2	C-852	Hex Bolt - 5/8 x 4 1/2 Lg.....	8
2A	S-1344	Hex Bolt - 5/8 x 5 1/2 Lg.....	4
3	C-3919	Hex Bolt - 3/4 x 5 1/2 Lg.....	8
4	C-5561	U-Bolt - 3/4 x 4 x 5 9/16	12
5	S47655	Tie Rod Pin	2
6	C18662	Wear Plate.....	2
7	C18782	Cap - 3 Dia.....	2
8	S44984	Spacer Tube	2
9	P61D20	Hex Nut - 1 1/4.....	4
10	S-752	Grease Zerk - 1/4.....	4
11	S45720	Offset Castor - 3/4 Side Plates - Dual Wheel	2
12	F10542	Spacer Plate	2
13	S44336	Outer Wing Lift Truss - Front	2
13A	S44337	Outer Wing Lift Truss - Rear.....	2
14	S42822	Pin - 1 1/2 x 5 1/8 UL	4
15	S49817	Tie Rod - 109 1/2 UL.....	2
16	S47084	Rear Axle Wing Depth Beam - 25 3/8 Lg - Prior to Sept. 2012	1
	S51025	Rear Axle Wing Depth Beam - 27 3/8 Lg	2
17	S42927	Outer Wing Frame	2
18	S42982	Outer Wing Depth Tube - (5 1/8) - Prior to Sept. 2012	2
	S51015	Outer Wing Depth Tube - 3 Lift (8 1/8)	2
19	S44314	Extention Stub - 10 inch spacing only - Prior to Sept. 2012 (Uses C-219 U-Bolt)	2
	S51022	HD Extention Stub - 10 inch spacing only.....	2
20	T-5245	Spiral Pin - 3/8 x 2 1/2 Lg	4
21	T-5268	Carriage Bolt - 5/8 x 2 Lg	8
21A	N33594	Carriage Bolt - 5/8 x 2 1/4 Lg	4
22	W-497	Hex Bolt - 5/8 x 1 1/2 Lg.....	2
23	W-509	Hex Bolt - 3/4 x 2 1/2 Lg.....	14
24	W-517	Hex Nut - 5/8.....	56
25	W-518	Hex Nut - 3/4.....	52
26	W-526	Lockwasher - 5/8.....	56
27	W-527	Lockwasher - 3/4.....	52
28	W-535	Cotter Pin - 1/4 x 1 1/2 Lg	2
29	W-558	Pin - 1 Dia x 2 1/4 UL.....	2
30	S44981	Support Beam - 88 1/4 Lg.....	2
31	S44348	Frame Extention	2
32	S42861	Extention Stub - 11 1/4 Lg - 12 inch spacing only	2
33	S44959	Trip Stop - 12 inch spacing only.....	2
34	W-498	Hex Bolt - 5/8 X 1 3/4 Lg - 12 inch spacing only	8
35	C-4569	U-Bolt - 5/8 x 4 1/32 x 3 1/4 - 12 inch spacing only.....	4
36	S42862	Extention Stub - 14 1/4 Lg - 10 and 12 inch spacing.....	2
37	C-695	Hex Bolt - 3/4 x 2 Lg.....	10
38	N15097	U-Bolt - 3/8 x 2 x 5 UL.....	8
39	W-514	Hex Nut - 3/8.....	16
40	W-523	Lockwasher - 3/8.....	16
41	S64080	Truss Support	4
	S64076	Kit Truss Support Outer Wing (Includes items 38, 39, 40, 41 and required qty of 1, 24, 26)	
		Prior to Sept. 2012	
		71' Prior to serial # C271132031	

Outer Wing - 80, 86 & 90 Ft

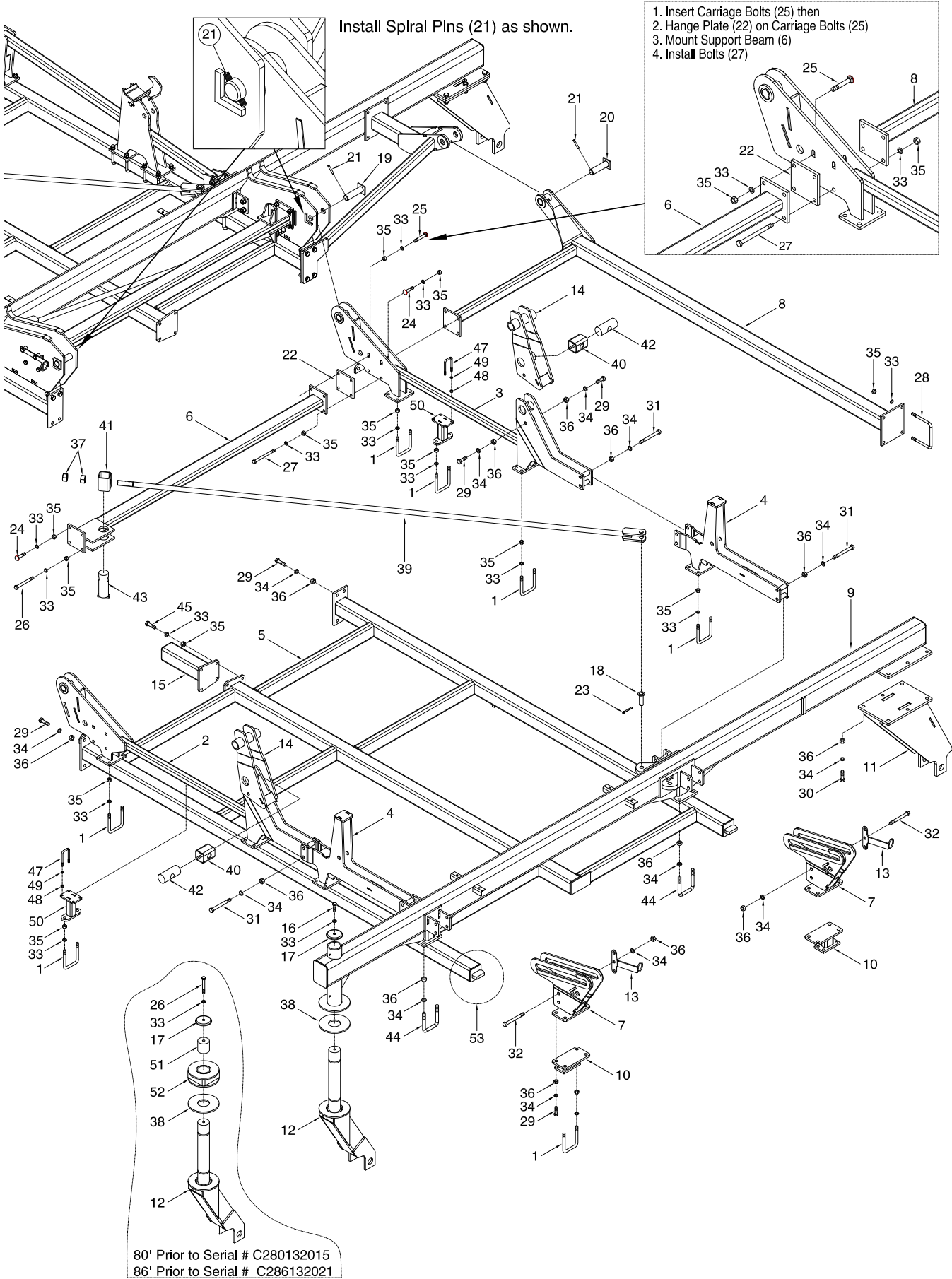

Outer Wing - 80, 86 & 90 Ft

Item	Part No.	Description	Qty
1	C-219	U-Bolt - 5/8 x 4 x 5 9/16 UL.....	36
2	S44336	Outer Wing Lift Truss - Front.....	2
3	S44337	Outer Wing Lift Truss - Rear.....	2
4	S45767	Flip Cylinder Bracket.....	4
5	S45276	Wing Frame - 80-86 Ft.....	2
6	S44981	Support Beam.....	2
7	S45759	Flip Hinge Bracket.....	4
8	S47050	Rear Truss - Outer - Left side.....	1
	S47522	Rear Truss - Outer - Right side.....	1
9	S42982	Outer Wing Depth Tube - (5 1/8) - Prior to Sept. 2012	2
	S51015	Depth Tube -Outer Wing - 3 Lift (8 1/8).....	2
10	S47060	Outer Hinge Brace.....	4
11	S47084	Rear Axle Wing Depth Beam - 25 3/8 Lg - Prior to Sept. 2012	1
	S51025	Rear Axle - Wing Depth Beam - 27 3/8 Lg.....	2
12	S45720	Offset Castor - 3/4 Side Plates.....	2
13	S47749	Hose Holder.....	4
14	S45780	Wing Lift Extension Bracket.....	4
15	S42862	Extention Stub - 14 1/4 Lg.....	2
16	W-497	Hex Bolt - 5/8 x 1 1/2 Lg.....	2
	C-852	Hex Bolt - 5/8 x 4 1/2 Lg - used with Castor Plug Item 46.....	2
17	C18782	Cap - 3 Dia.....	2
18	W-558	Pin - 1 x 2 1/4 UL.....	2
19	S42822	Pin - 1 1/2 x 5 1/8 UL.....	4
20	S47518	Pin - 1 1/2 x 5 5/8 UL.....	2
21	T-5245	Spiral Pin - 3/8 x 2 1/2 Lg.....	6
22	F10542	Spacer Plate.....	2
23	W-535	Cotter Pin - 1/4 x 1 1/2 Lg.....	2
24	T-5268	Carriage Head Bolt - 5/8 x 2 Lg.....	8
25	N33594	Carriage Head Bolt - 5/8 x 2 1/4 Lg.....	4
26	C-852	Hex Bolt - 5/8 x 4 1/2 Lg.....	4
27	S-1344	Hex Bolt - 5/8 x 5 1/2 Lg.....	4
28	N33342	U-Bolt - 5/8 x 7 x 6 1/2 Lg.....	4
29	C-695	Hex Bolt - 3/4 x 2 Lg.....	32
30	W-509	Hex Bolt - 3/4 x 2 1/2 Lg.....	14
31	C-3919	Hex Bolt - 3/4 x 5 1/2 Lg.....	8
32	D-5558	Hex Bolt - 3/4 x 6 Lg.....	8
33	W-526	Lockwasher - 5/8.....	110
34	W-527	Lockwasher - 3/4.....	78
35	W-517	Hex Nut - 5/8.....	110
36	W-518	Hex Nut - 3/4.....	78
37	P61D20	Hex Nut - 1 1/4.....	4
38	C18662	Wear Washer.....	2
39	S45794	Tie Rod - 1 1/4 x 136 1/2 Lg (pin center to end).....	2
40	S42813	Spacer Tube - 3 x 3 x 2 7/16 Lg.....	4
41	S44984	Spacer Tube - 3 x 3 x 4 Lg.....	2
42	S47600	Pin - Wing Pivot - 2 1/2 Dia x 5 1/4 Lg.....	4
43	S47655	Pin - Tie Rod - 2 1/2 Dia x 7 Lg.....	2
44	C-5561	U-Bolt - 3/4 x 4 x 5 9/16.....	8
45	W-498	Hex Bolt - 5/8 X 1 3/4 Lg.....	8
47	N15097	U-Bolt - 3/8 x 2 x 5 UL.....	8
48	W-514	Hex Nut - 3/8.....	16
49	W-523	Lockwasher - 3/8.....	16
50	S64080	Truss Support.....	4
51	S42434	Castor Plug - 3 x 3 Lg.....	2
52	S42440	Castor Spacer - 2 3/4.....	2
53	S47059	Frame Stop - 80-86 Ft (Shown on Flip Wing Assembly 2013-2015).....	4
53A	S53925	Stud Plate - 80-86 Ft (Shown on Flip Wing Assembly 2016 to Present).....	4
53B	S53925	Stud Plate - 90 Ft (Shown on Flip Wing Assembly).....	4
	S64076	Kit Truss Support Outer Wing (Includes items 47, 48, 49, 50 and required qty of 1, 33, 35)	

Flip Wing - 80 & 86 Ft - Prior to December 2013

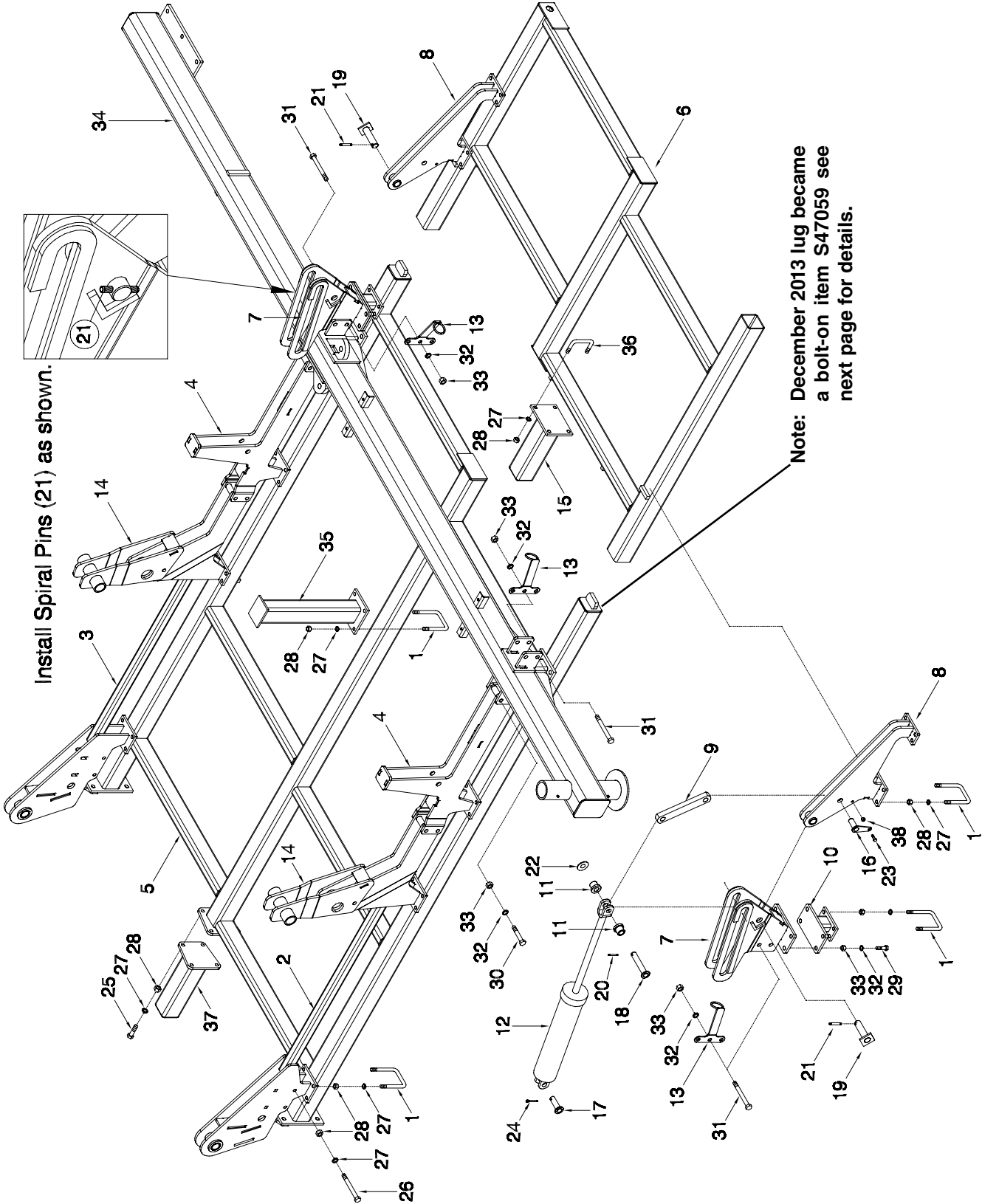

Flip Wing - 80 & 86 Ft - Prior to December 2013

Item	Part No.	Description	Qty
1	C-219	U-Bolt - 5/8 x 4 x 5 9/16 UL.....	48
2	S44336	Outer Wing Lift Truss - Front	2
3	S44337	Outer Wing Lift Truss - Rear.....	2
4	S45767	Flip Cylinder Bracket.....	4
5	S45276	Wing Frame - 80-86 Ft	2
6	S47531	Flip Wing - 80 Ft.....	2
	S49841	Flip Wing - 86 Ft (Shown)	2
7	S45759	Flip Hinge Bracket.....	4
8	S45771	Outer Flip Hinge.....	4
9	N33796	Wing Lift Link - 1 x 2 x 11 1/2 Lg - 1 Dia holes - 9 1/4 Hole Centers.....	4
10	S47060	Outer Hinge Brace	4
11	N33797	Wing Lift Roller.....	8
12	*****	Cylinder - See Hydraulic Section	4
13	S47749	Hose Holder	4
14	S45780	Wing Lift Extension Bracket	4
15	S47644	Extension Stub - 15 1/16 Lg.....	2
16	S49850	Pin - 1 x 2 13/32 UL	4
17	W-1628	Pin - 1 x 3 3/4 UL	4
18	S13261	Pin - 1 x 5 5/8 UL	4
19	S45796	Pin - 1 1/4 x 4 1/16 UL	4
20	D-5244	Spiral Pin - 1/4 x 2 Lg.....	4
21	T-5245	Spiral Pin - 3/8 x 2 1/2 Lg.....	4
22	D-5498	Washer - 1 1/16 ID x 2 OD x 11 Ga.....	4
23	W-187	Hex Bolt - 3/8 x 1 1/4	4
24	W-535	Cotter Pin - 1/4 x 1 1/2 Lg	4
25	W-498	Hex Bolt - 5/8 x 1 3/4 Lg.....	8
26	W-506	Hex Bolt - 5/8 x 5 Lg.....	16
27	W-526	Lockwasher - 5/8.....	120
28	W-517	Hex Nut - 5/8.....	120
29	C-695	Hex Bolt - 3/4 x 2 Lg.....	32
30	C-3919	Hex Bolt - 3/4 x 5 1/2 Lg.....	8
31	D-5558	Hex Bolt - 3/4 x 6 Lg.....	8
32	W-527	Lockwasher - 3/4.....	48
33	W-518	Hex Nut - 3/4.....	48
34	S42982	Depth Tube - Outer Wing - (5 1/8 - Prior to Sept. 2012	2
	S51015	Depth Tube - Outer Wing - 3 Lift (8 1/8).....	2
35	S47656	Wing Rest - 80 Ft.....	2
36	C-4569	U-Bolt - 5/8 x 4 x 3 1/4 UL.....	4
37	S42862	Extention Stub - 14 1/4 Lg.....	2
38	M-3388	Hex Lock Nut - 3/8	4

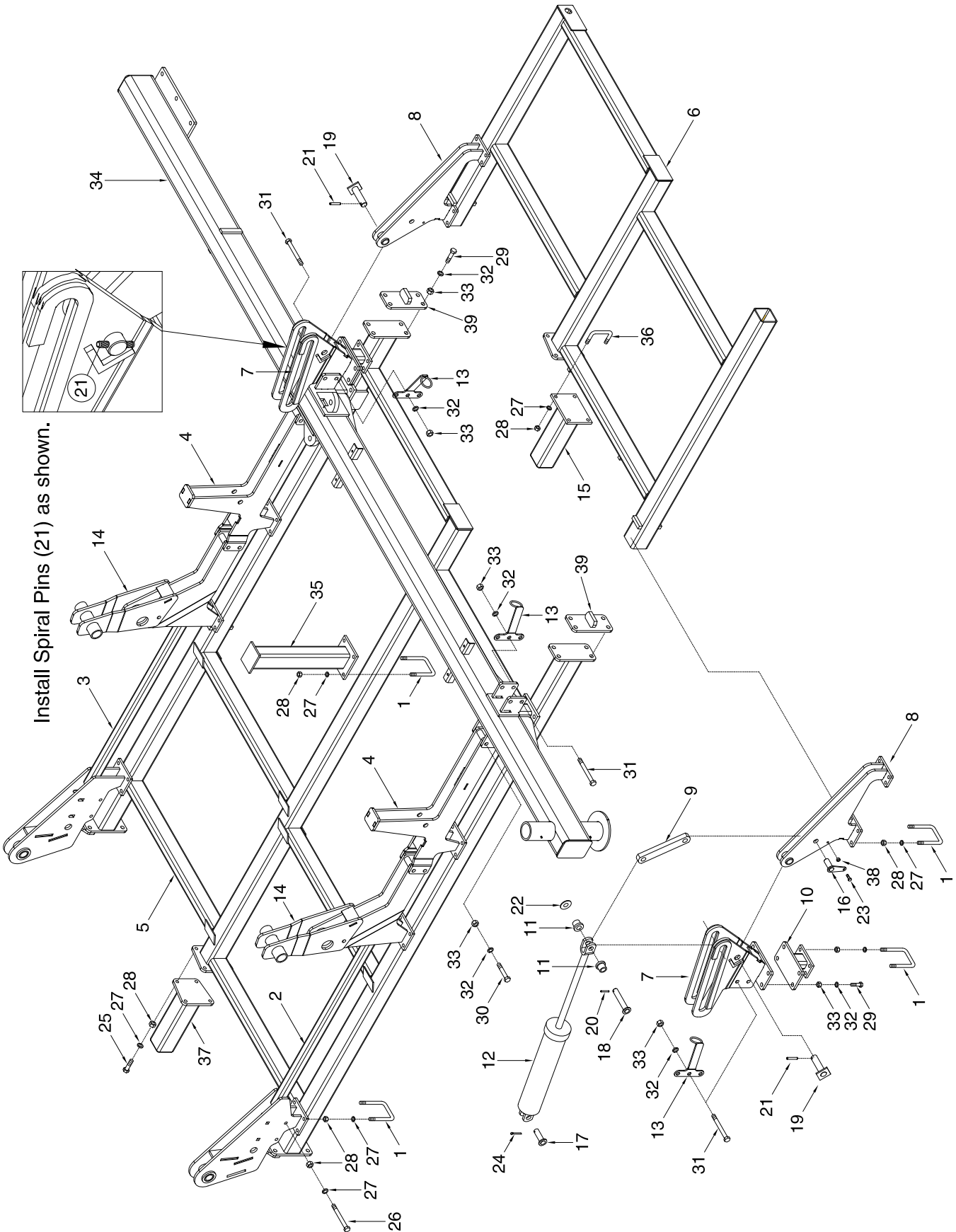

Flip Wing - 80 & 86 Ft - December 2013 to 2015

Item	Part No.	Description	Qty
1	C-219	U-Bolt - 5/8 x 4 x 5 9/16 UL.....	48
2	S44336	Outer Wing Lift Truss - Front	2
3	S44337	Outer Wing Lift Truss - Rear.....	2
4	S45767	Flip Cylinder Bracket	4
5	S45276	Wing Frame - 80-86 Ft	2
6	S47531	Flip Wing - 80 Ft.....	2
	S49841	Flip Wing - 86 Ft (Shown)	2
7	S45759	Flip Hinge Bracket.....	4
8	S45771	Outer Flip Hinge.....	4
9	N33796	Wing Lift Link - 1 x 2 x 11 1/2 Lg - 1 Dia holes - 9 1/4 Hole Centers	4
10	S47060	Outer Hinge Brace	4
11	N33797	Wing Lift Roller.....	8
12	*****	Cylinder - See Hydraulic Section	4
13	S47749	Hose Holder	4
14	S45780	Wing Lift Extension Bracket	4
15	S47644	Extension Stub - 15 1/16 Lg.....	2
16	S49850	Pin - 1 x 2 13/32 UL	4
17	W-1628	Pin - 1 x 3 3/4 UL	4
18	S13261	Pin - 1 x 5 5/8 UL	4
19	S45796	Pin - 1 1/4 x 4 1/16 UL	4
20	D-5244	Spiral Pin - 1/4 x 2 Lg.....	4
21	T-5245	Spiral Pin - 3/8 x 2 1/2 Lg.....	4
22	D-5498	Washer - 1 1/16 ID x 2 OD x 11 Ga.....	4
23	W-187	Hex Bolt - 3/8 x 1 1/4	4
24	W-535	Cotter Pin - 1/4 x 1 1/2 Lg	4
25	W-498	Hex Bolt - 5/8 x 1 3/4 Lg.....	8
26	W-506	Hex Bolt - 5/8 x 5 Lg.....	16
27	W-526	Lockwasher - 5/8.....	120
28	W-517	Hex Nut - 5/8.....	120
29	C-695	Hex Bolt - 3/4 x 2 Lg	48
30	C-3919	Hex Bolt - 3/4 x 5 1/2 Lg.....	8
31	D-5558	Hex Bolt - 3/4 x 6 Lg.....	8
32	W-527	Lockwasher - 3/4	64
33	W-518	Hex Nut - 3/4	64
34	S51015	Depth Tube - Outer Wing - 3 Lift (8 1/8).....	2
35	S47656	Wing Rest - 80 Ft.....	2
36	C-4569	U-Bolt - 5/8 x 4 x 3 1/4 UL.....	4
37	S42862	Extention Stub - 14 1/4 Lg.....	2
38	M-3388	Hex Lock Nut - 3/8	4
39	S47059	Frame Stop.....	4

Flip Wing - 80 & 86 Foot - 2016 to Present

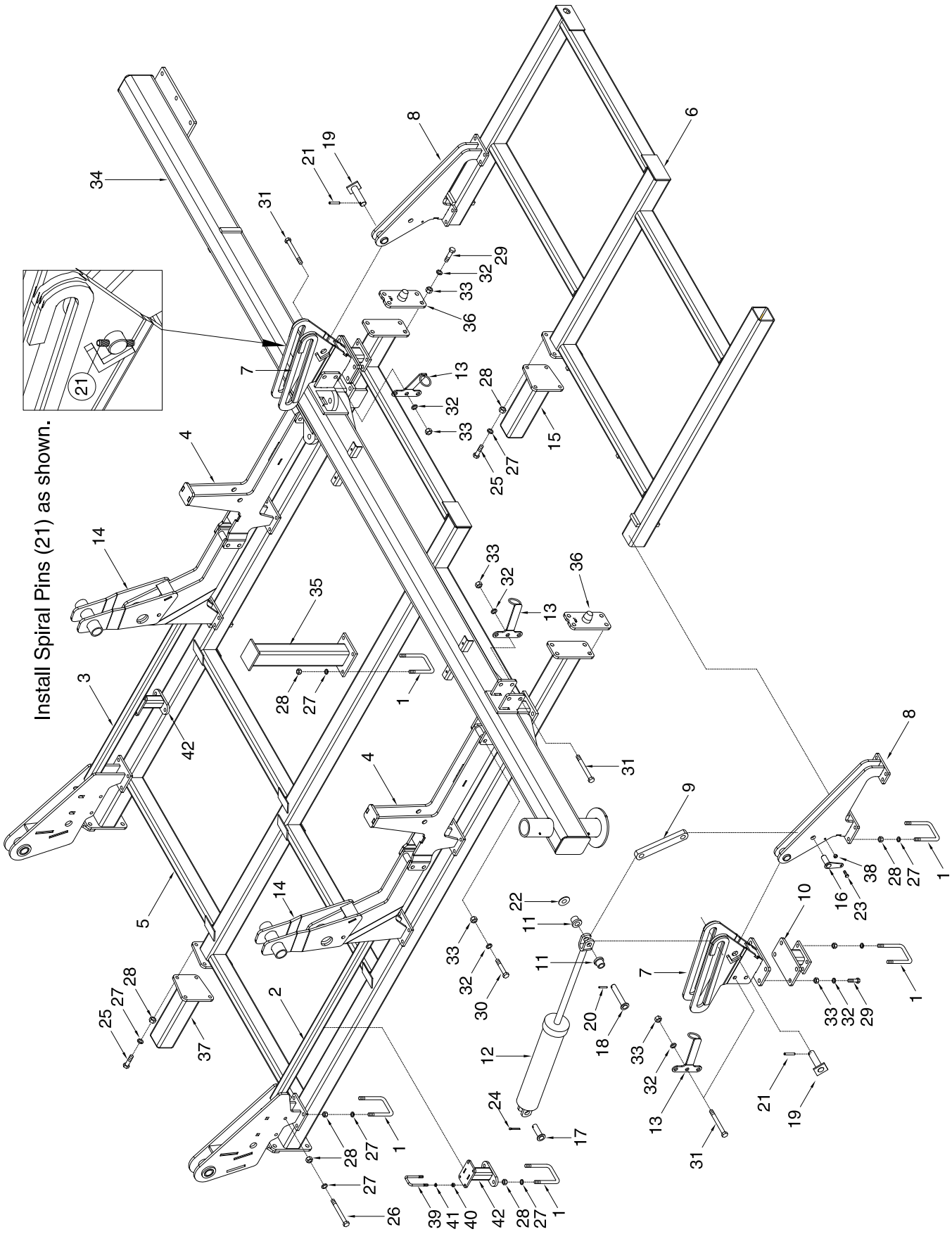

Install Spiral Pins (21) as shown.

Flip Wing - 80 & 86 Foot - 2016 to Present

Item	Part No.	Description	Qty
1	C-219	U-Bolt - 5/8 x 4 x 5 9/16 UL.....	52
2	S44336	Outer Wing Lift Truss - Front	2
3	S44337	Outer Wing Lift Truss - Rear.....	2
4	S45767	Flip Cylinder Bracket	4
5	S45276	Wing Frame - 80-86 Ft	2
6	S59866	Flip Wing - 2016 - 80 Ft.....	2
	S49841	Flip Wing - 86 Ft (Shown)	2
7	S45759	Flip Hinge Bracket.....	4
8	S45771	Outer Flip Hinge.....	4
9	N33796	Wing Lift Link - 1 x 2 x 11 1/2 Lg - 1 Dia holes - 9 1/4 Hole Centers	4
10	S47060	Outer Hinge Brace	4
11	N33797	Wing Lift Roller.....	8
12	*****	Cylinder - See Hydraulic Section	4
13	S47749	Hose Holder	4
14	S45780	Wing Lift Extension Bracket	4
15	S42862	Extention Stub - 14 1/4 Lg - 86 Ft only.....	2
16	S49850	Pin - 1 x 2 13/32 UL	4
17	W-1628	Pin - 1 x 3 3/4 UL	4
18	S13261	Pin - 1 x 5 5/8 UL	4
19	S45796	Pin - 1 1/4 x 4 1/16 UL	4
20	D-5244	Spiral Pin - 1/4 x 2 Lg.....	4
21	T-5245	Spiral Pin - 3/8 x 2 1/2 Lg.....	4
22	D-5498	Washer - 1 1/16 ID x 2 OD x 11 Ga.....	4
23	W-187	Hex Bolt - 3/8 x 1 1/4	4
24	W-535	Cotter Pin - 1/4 x 1 1/2 Lg	4
25	W-498	Hex Bolt - 5/8 x 1 3/4 Lg.....	16
26	W-506	Hex Bolt - 5/8 x 5 Lg.....	16
27	W-526	Lockwasher - 5/8.....	128
28	W-517	Hex Nut - 5/8	128
29	C-695	Hex Bolt - 3/4 x 2 Lg.....	48
30	C-3919	Hex Bolt - 3/4 x 5 1/2 Lg.....	8
31	D-5558	Hex Bolt - 3/4 x 6 Lg.....	8
32	W-527	Lockwasher - 3/4.....	64
33	W-518	Hex Nut - 3/4	64
34	S51015	Depth Tube - Outer Wing - 3 Lift (8 1/8).....	2
35	S47656	Wing Rest - 80 Ft only.....	2
36	S53925	Stud Plate - Frame Alignment	4
37	S42862	Extention Stub - 14 1/4 Lg.....	2
38	M-3388	Hex Lock Nut - 3/8	4
39	N15097	U-Bolt - 3/8 x 2 x 5 UL.....	8
40	W-514	Hex Nut - 3/8	16
41	W-523	Lockwasher - 3/8.....	16
42	S64080	Truss Support	4
	S64076	Kit Truss Support Outer Wing (Includes items 39, 40, 41, 42 and required qty of 1, 27, 28)	

Flip Wing - 90 Ft - Prior to 2016

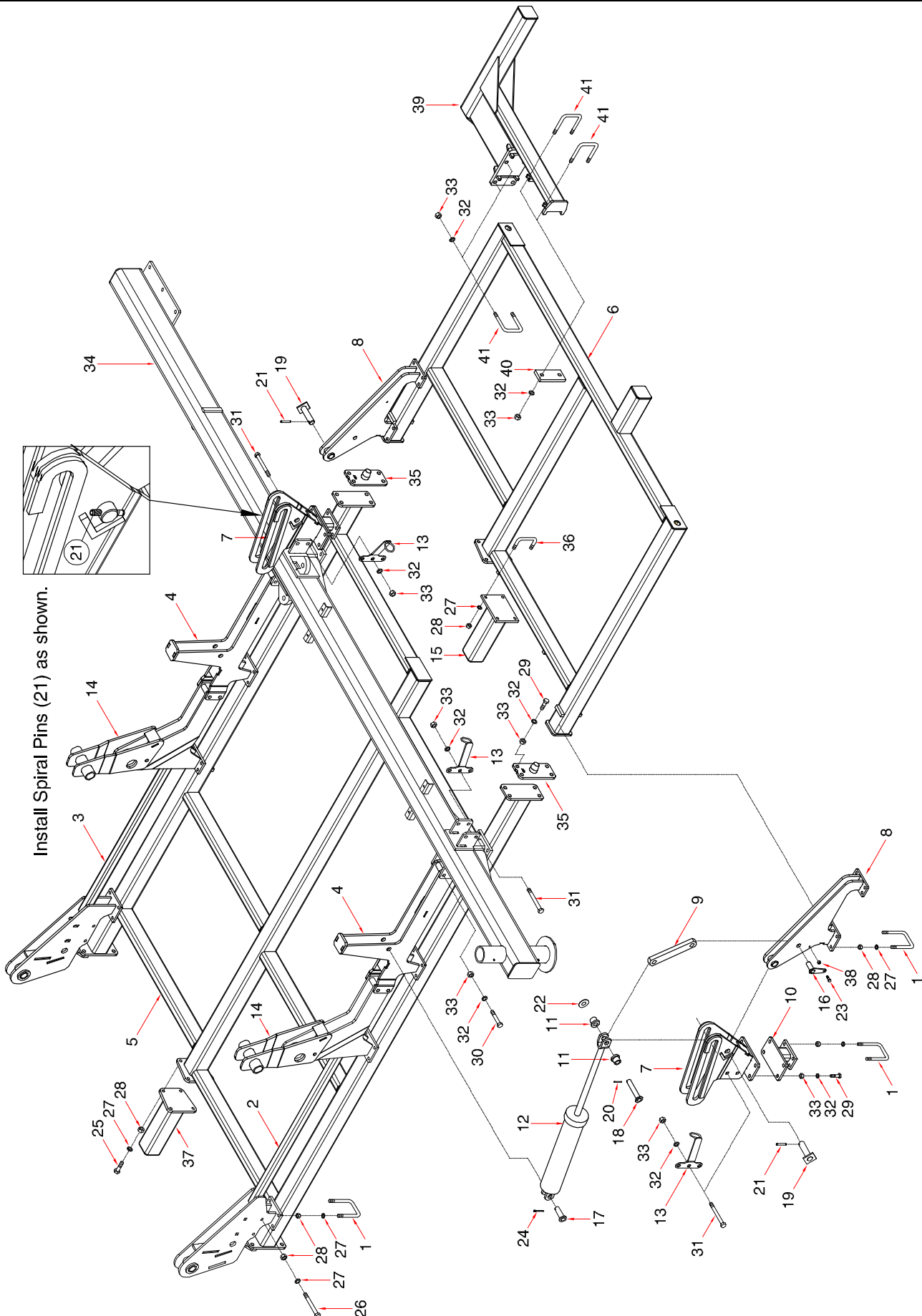

Install Spiral Pins (21) as shown.

Flip Wing - 90 Ft - Prior to 2016

Item	Part No.	Description	Qty
1	C-219	U-Bolt - 5/8 x 4 x 5 9/16 UL.....	48
2	S44336	Outer Wing Lift Truss - Front	2
3	S44337	Outer Wing Lift Truss - Rear.....	2
4	S45767	Flip Cylinder Bracket	4
5	S45276	Wing Frame - 80-86-90 Ft.....	2
6	S49855	Flip Wing - 90 Ft.....	2
7	S45759	Flip Hinge Bracket.....	4
8	S45771	Outer Flip Hinge.....	4
9	N33796	Wing Lift Link - 1 x 2 x 11 1/2 Lg - 1 Dia holes - 9 1/4 Hole Centers	4
10	S47060	Outer Hinge Brace	4
11	N33797	Wing Lift Roller.....	8
12	*****	Cylinder - See Hydraulic Section	4
13	S47749	Hose Holder	4
14	S45780	Wing Lift Extension Bracket	4
15	S47644	Extension Stub - 15 1/16 Lg.....	2
16	S49850	Pin - 1 x 2 13/32 UL	4
17	W-1628	Pin - 1 x 3 3/4 UL	4
18	S13261	Pin - 1 x 5 5/8 UL	4
19	S45796	Pin - 1 1/4 x 4 1/16 UL	4
20	D-5244	Spiral Pin - 1/4 x 2 Lg.....	4
21	T-5245	Spiral Pin - 3/8 x 2 1/2 Lg.....	4
22	D-5498	Washer - 1 1/16 ID x 2 OD x 11 Ga.....	4
23	W-187	Hex Bolt - 3/8 x 1 1/4	4
24	W-535	Cotter Pin - 1/4 x 1 1/2 Lg	4
25	W-498	Hex Bolt - 5/8 x 1 3/4 Lg.....	8
26	W-506	Hex Bolt - 5/8 x 5 Lg.....	16
27	W-526	Lockwasher - 5/8.....	120
28	W-517	Hex Nut - 5/8.....	120
29	C-695	Hex Bolt - 3/4 x 2 Lg.....	48
30	C-3919	Hex Bolt - 3/4 x 5 1/2 Lg.....	8
31	D-5558	Hex Bolt - 3/4 x 6 Lg.....	8
32	W-527	Lockwasher - 3/4.....	80
33	W-518	Hex Nut - 3/4.....	80
34	S51015	Depth Tube - Outer Wing - 3 Lift (8 1/8).....	2
35	S53925	Stud Plate - Frame Alignment	2
36	C-4569	U-Bolt - 5/8 x 4 x 3 1/4 UL.....	4
37	S42862	Extention Stub - 14 1/4 Lg.....	2
38	M-3388	Hex Lock Nut - 3/8	4
39	S53145	Extention Frame - 90 Ft.....	2
40	C29194	Clamp Plate	4
41	C26447	U-Bolt - 3/4 x 4 x 7 UL.....	8

Flip Wing - 90 Ft - 2016 to Present

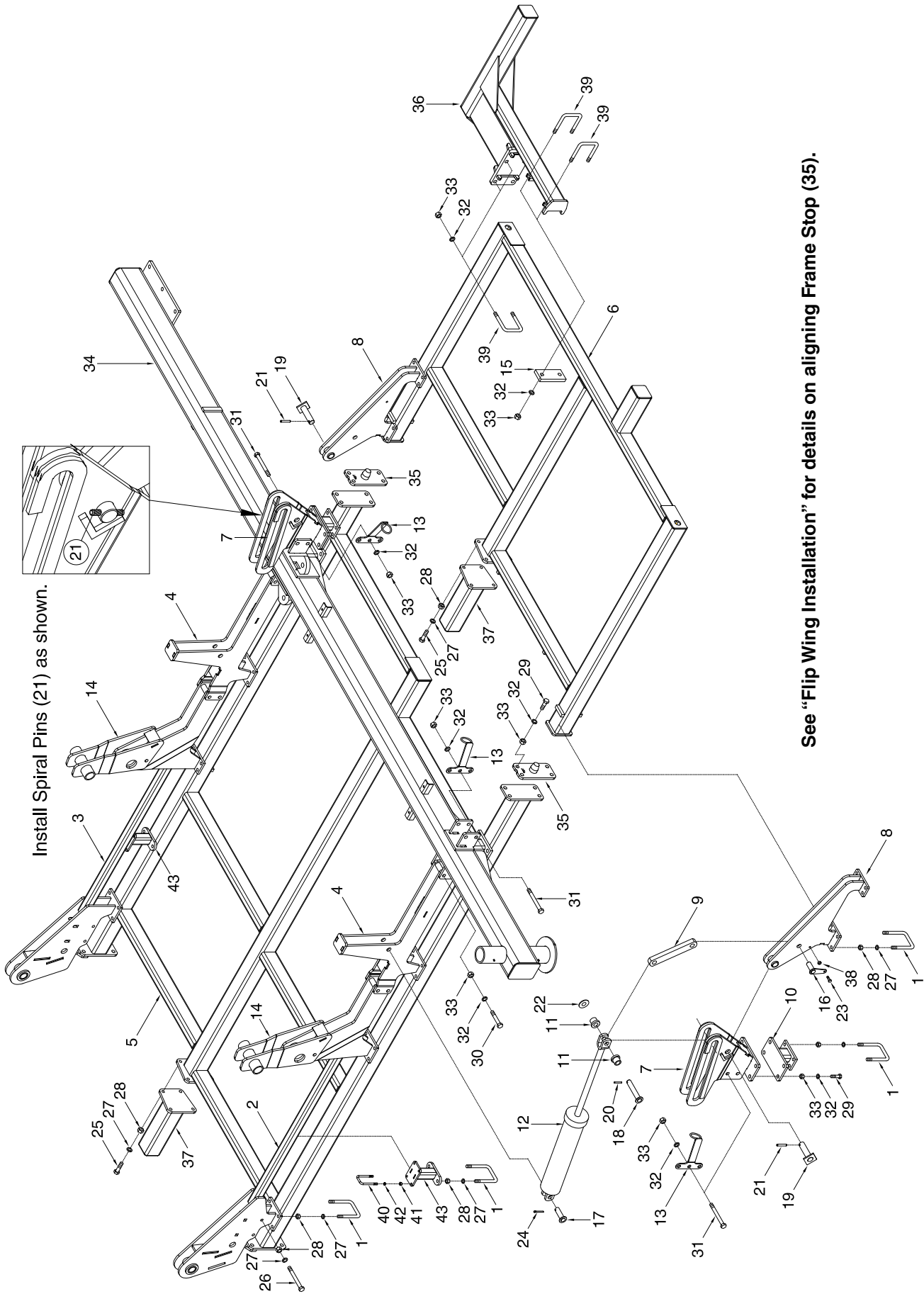

Install Spiral Pins (21) as shown.

See "Flip Wing Installation" for details on aligning Frame Stop (35).

Flip Wing - 90 Ft - 2016 to Present

Item	Part No.	Description	Qty
1	C-219	U-Bolt - 5/8 x 4 x 5 9/16 UL.....	52
2	S44336	Outer Wing Lift Truss - Front	2
3	S44337	Outer Wing Lift Truss - Rear.....	2
4	S45767	Flip Cylinder Bracket	4
5	S45276	Wing Frame - 80-86-90 Ft.....	2
6	S49855	Flip Wing - 90 Ft.....	2
7	S45759	Flip Hinge Bracket.....	4
8	S45771	Outer Flip Hinge.....	4
9	N33796	Wing Lift Link - 1 x 2 x 11 1/2 Lg - 1 Dia holes - 9 1/4 Hole Centers	4
10	S47060	Outer Hinge Brace	4
11	N33797	Wing Lift Roller.....	8
12	*****	Cylinder - See Hydraulic Section	4
13	S47749	Hose Holder	4
14	S45780	Wing Lift Extension Bracket	4
15	C29194	Clamp Plate	4
16	S49850	Pin - 1 x 2 13/32 UL	4
17	W-1628	Pin - 1 x 3 3/4 UL	4
18	S13261	Pin - 1 x 5 5/8 UL	4
19	S45796	Pin - 1 1/4 x 4 1/16 UL	4
20	D-5244	Spiral Pin - 1/4 x 2 Lg.....	4
21	T-5245	Spiral Pin - 3/8 x 2 1/2 Lg.....	4
22	D-5498	Washer - 1 1/16 ID x 2 OD x 11 Ga.....	4
23	W-187	Hex Bolt - 3/8 x 1 1/4	4
24	W-535	Cotter Pin - 1/4 x 1 1/2 Lg	4
25	W-498	Hex Bolt - 5/8 x 1 3/4 Lg.....	16
26	W-506	Hex Bolt - 5/8 x 5 Lg.....	16
27	W-526	Lockwasher - 5/8.....	128
28	W-517	Hex Nut - 5/8.....	128
29	C-695	Hex Bolt - 3/4 x 2 Lg.....	48
30	C-3919	Hex Bolt - 3/4 x 5 1/2 Lg.....	8
31	D-5558	Hex Bolt - 3/4 x 6 Lg.....	8
32	W-527	Lockwasher - 3/4.....	80
33	W-518	Hex Nut - 3/4.....	80
34	S51015	Depth Tube - Outer Wing - 3 Lift (8 1/8).....	2
35	S53925	Stud Plate - Frame Alignment	2
36	S53145	Extention Frame - 90 Ft.....	2
37	S42862	Extention Stub - 14 1/4 Lg.....	4
38	M-3388	Hex Lock Nut - 3/8	4
39	C26447	U-Bolt - 3/4 x 4 x 7 UL.....	8
40	N15097	U-Bolt - 3/8 x 2 x 5 UL.....	8
41	W-514	Hex Nut - 3/8.....	16
42	W-523	Lockwasher - 3/8.....	16
43	S64080	Truss Support	4
	S64076	Kit Truss Support Outer Wing (Includes items 40, 41, 42, 43 and required qty of 1, 27, 28)	

Frames & Hitching Wing Lift - 5 Frame

See "Flip Wing - 80 & 86 Foot" for
Details on 80 & 86 ft Outer Flip Wing.

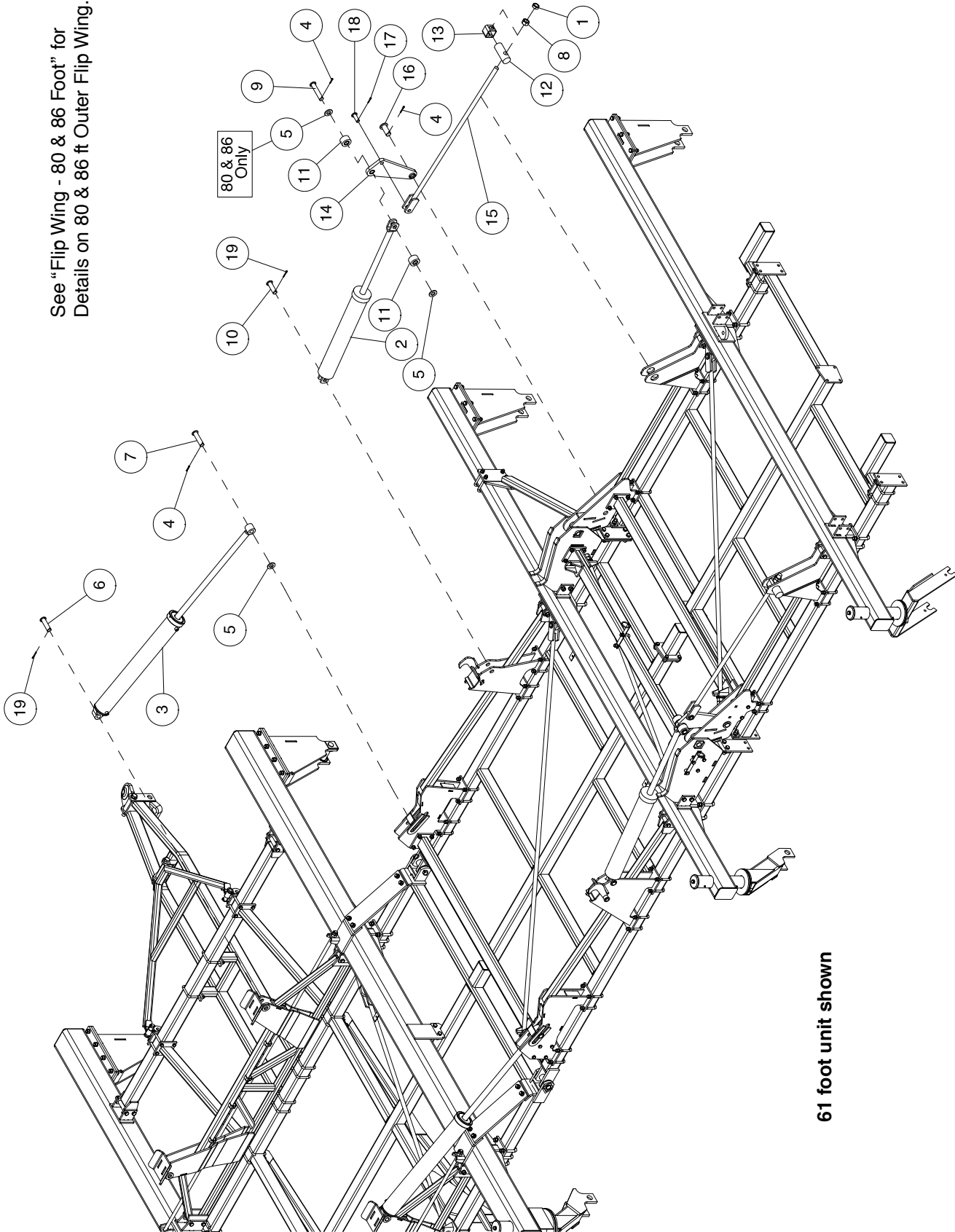

61 foot unit shown

Frames & Hitching - Wing Lift - 5 Frame

Item	Part No.	Description	Qty
1	C15768	Hex Jam Nut - 1 1/4	4
2	C34442	Cylinder - 4 1/2 x 30 - 61 ft and 71 ft	4
	C47594	Cylinder - 5 x 30 - 80 ft and 86 ft - Prior to September 2013	4
	C53255	Cylinder - 5 1/2 x 30 - 80 ft to 90 ft - September 2013 to present	4
3	C39030	Cylinder - 4 1/2 x 36 - 61 ft	4
	C39490	Cylinder - 5 x 36 - 71 ft	4
	C39490	Cylinder - 5 x 36 - 80 ft to 86 ft - Prior to September 2013	4
	C53250	Cylinder - 5 1/2 x 36 - 80 to 90 ft - September 2013 to present	4
4	D-5244	Spiral Pin - 1/4 x 2	12
5	N13962	Washer - 2 1/2 OD x 1 9/32 ID x 1/4 - 61 ft and 71 ft	8
	N13962	Washer - 2 1/2 OD x 1 9/32 ID x 1/4 - 80 ft to 90 ft	12
6	N28994	Pin - 1 1/4 Dia x 4 1/4 UL	4
7	N28998	Pin - 1 1/4 x 4 3/4 UL	4
8	P61D20	Hex Nut - 1 1/4	4
9	N33874	Pin - 1 1/4 Dia x 6 3/16 UL - 61 ft and 71 ft	4
	S47595	Pin - 1 1/4 Dia x 6 1/2 UL - 80 ft to 90 ft	4
10	N28994	Pin - 1 1/4 x 4 1/4 UL	4
11	S39570	Outer Wing Lift Roller - 1.258 ID x 3 OD x 1 3/4 wide	8
12	S44983	Outer Wing Lift Pivot	4
	S47600	Pin - Wing Pivot - 2 1/2 Dia x 5 1/4 Lg - 80 ft to 90 ft	4
13	S42813	Spacer Tube	4
14	S42815	Outer Wing Lift Lever - 15 3/4 bushing hole centers - 61 ft and 71 ft	4
	S45779	Outer Wing Lift Lever - 17 1/2 bushing hole centers - 80 ft to 90 ft	4
		S39567 - Bushing - 1.258 ID x 1.63 OD x 1 Lg (Used in above Links)	1
15	S42828	Tie Rod - Outer 8' Wing Lift - 61 UL	4
16	S44311	Pin - 1 1/2 Dia x 3 1/16 UL	4
17	W-535	Cotter Pin - 1/4 x 1 1/2 Lg	4
18	W-558	Pin - 1 Dia x 2 1/4 UL	4
19	W-4181	Cotter Pin - 1/4 x 2 Lg	8

Frames & Hitching Lift Kit - 41 Ft to 71 Ft

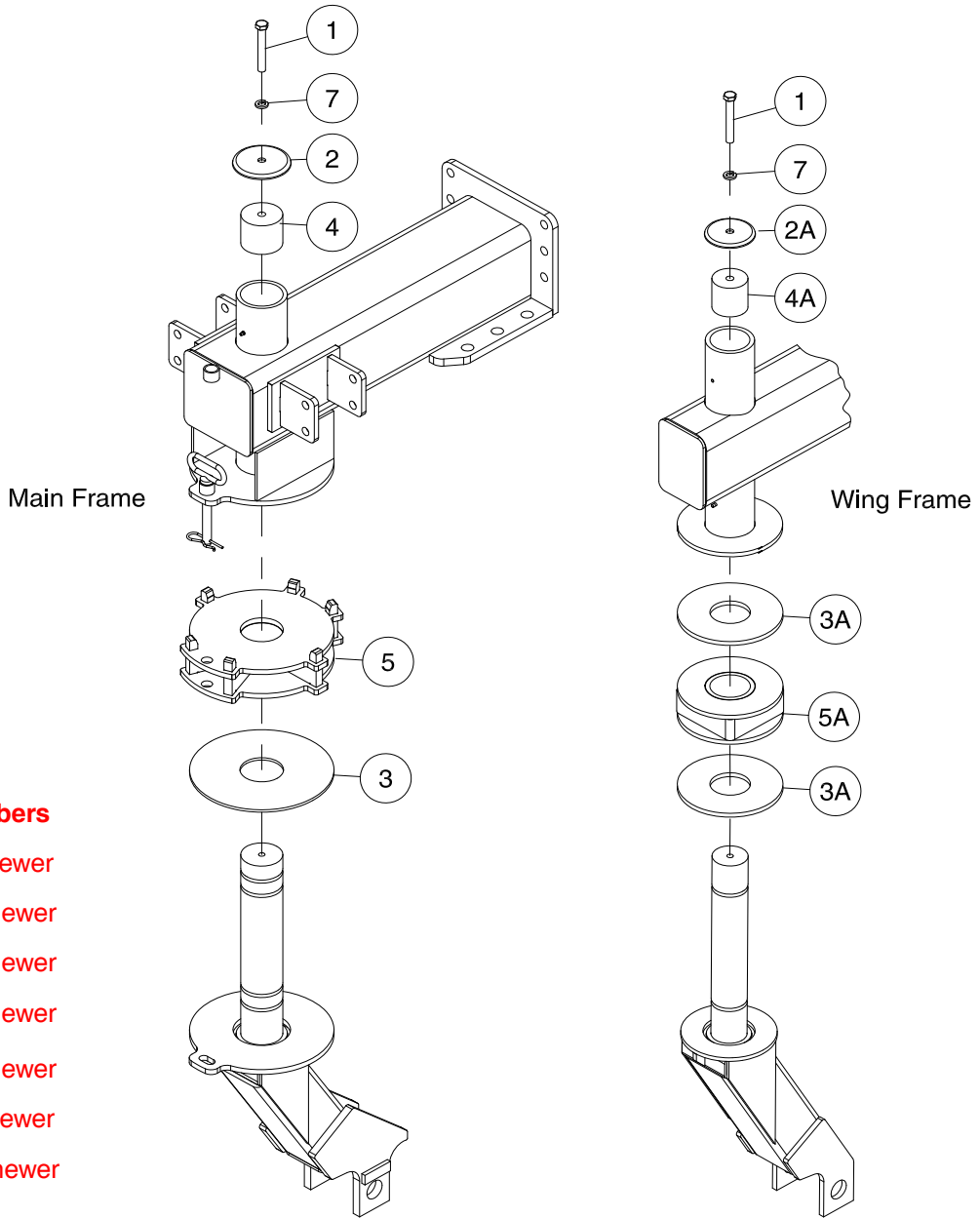

Not for use on Serial numbers

- 31' C2 – C231132012 and newer
- 41' C2 – C241132025 and newer
- 51' C2 – C251132035 and newer
- 61' C2 – C261132067 and newer
- 71' C2 – C271132031 and newer
- 80' C2 – C280132015 and newer
- 86' C2 – C286132021 and newer

Item	Part No.	Description	No. Used	
			3 Frame	5 Frame
1	C-852	Hex Bolt - 5/8 x 4 1/2 Lg	4	6
2	C18781	Cap - 3 1/2 Dia - Main Frame	2	2
2A	C18782	Cap - 3 Dia - Wing Frame	2	4
3	S39728	Wear Washer - Main Frame	2	4
3A	C18662	Wear Washer - Wing Frame	4	8
4	S51179	Castor Plug - 3 1/2 Dia - Main Frame	2	4
4A	S42434	Castor Plug - 3 Dia - Wing Frame	2	4
5	S45290	Castor Spacer - Main Frame	2	2
5A	S42440	Castor Spacer - Wing Frame	2	4
6	W-526	Lockwasher - 5/8	4	6
	G46925	Lift Kit - 3 frame		
	G46926	Lift Kit - 5 frame		

Section 2: Wheels

Section Contents

Main Dual Wheels.....	2-2
Front Axle Castor - 41 Ft to 90 Ft - 2018 to Present	2-2
Front Axle Castor - 41 Ft to 90 Ft - Prior to 2018	2-3
Rear Axles - 41 Ft to 90 Ft - 2018 to Present	2-4
Rear Axles - 41 Ft to 90 Ft - Prior to 2018	2-5
Main Single Wheels.....	2-6
Front Axle Castor - 25 and 31 Ft	2-6
Rear Axle - 25 and 31 Ft.....	2-7
Wing Dual Wheels	2-8
Front Axle Castor - 41 Ft to 90 Ft - 2018 to Present	2-8
Front Axle Castor - 41 Ft to 90 Ft - Prior to 2018	2-9
Rear Axle - 80 to 90 Ft - 2018 to Present	2-10
Rear Axle - 80 to 90 Ft - Prior to 2018	2-11
Wing Single Wheels.....	2-12
Front Axle Castor - 25 Ft and 31 Ft.....	2-12
Rear Axle - 25 Ft to 71 Ft.....	2-13

Main Dual Wheels Front Axle Castor - 41 Ft to 90 Ft - 2018 to Present

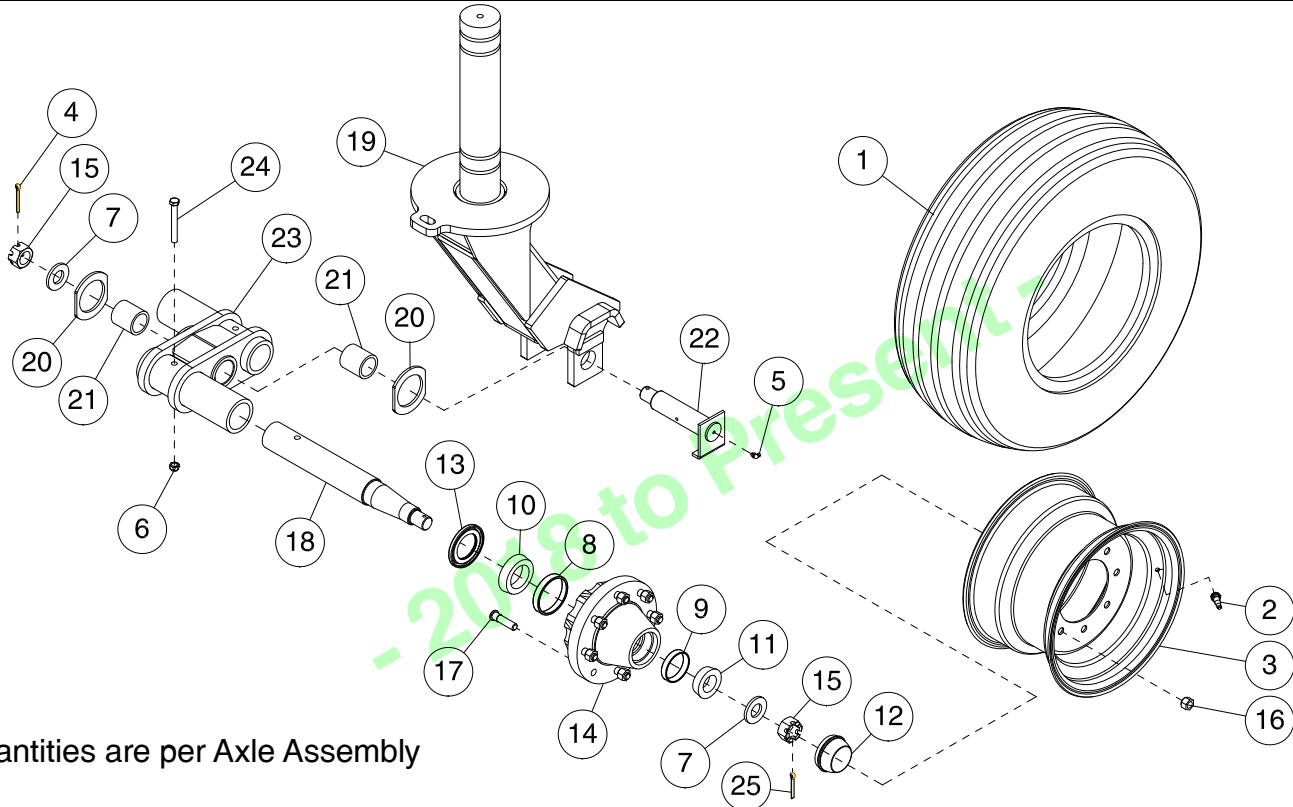

Quantities are per Axle Assembly

Item	Part No.	Description	Qty
1	C16609	Tire - 11L x 15FI - Load Range F - 41 ft & 51 ft Models	2
	C26840	Tire - 12.5L x 15FI - Load Range F - 61 ft & 71 ft Models	2
	S47510	Tire - 16.5L x 16.1 1FI - Load Range E - 80 ft to 90 ft Models (61 & 71 Optional)	2
2	C17348	Valve Stem - TR-416.....	2
3	C17355	Rim - 15 x 10 - 8 Bolt - 41ft to 71ft Models.....	2
	S47512	Rim - 16.1 x 14 - 8 Bolt - 80 ft to 90 ft Models (61 & 71 with optional 16.5L tires).....	2
4	D-5239	Cotter Pin - 1/4 x 2 1/4 Lg.....	1
5	F-3056	Grease Zerk - 1/4 NPT 90 degree.....	1
6	F-3405	Locknut - 1/2 Unitorque.....	2
7	N13962	Washer - 2-1/2 OD x 1-9/32 ID x 1/4	2
8	N19167	Inner Bearing Cup.....	1
9	N19168	Outer Bearing Cup.....	1
10	N19169	Inner Wheel Bearing	1
11	N19170	Outer Wheel Bearing.....	1
12	N19171	Dust Cap	1
13	N19172	Seal.....	1
14	N19173	Hub (Includes Items 8, 9 & 17).....	1
15	N19484	Hex Slotted Nut - 1-1/4 - 12 UNF.....	2
16	N19586	Hex Nut - 5/8.....	8
17	N19727	Wheel Stud - 5/8 - 18 UNF x 2 1/2 Lg.....	8
18	S32556	Spindle - 2 1/2 - 41 ft to 71ft Models	2
	S47509	Spindle - 2 1/2 - 80 ft to 90 ft Models (61 ft & 71 ft with optional 16.5L tires)	2
19	S44309	Castor Fork - 41 ft to 71 ft.....	1
	S53265	Castor Fork - 61 ft & 71 ft with Optional 16.5L Tires	1
	S53265	Castor Fork - 80 ft to 90 ft.....	1
20	S55629	Wear Washer - only used on the S62050 walking beam.....	2
21	S62027	Axle Pivot Bushing - 1.75 ID x 2.25 OD x 1.875Lg (Used in S62085)	2
	S55639	Axle Pivot Bushing - 1.75 ID x 2.25 OD x 2.375Lg (Used in S62050).....	2
22	S62026	Pivot Pin - Greasable - 1 3/4 Dia x 6 1/2 UL (Includes item 5).....	1
23	S62085	Walking Beam - 41 ft to 71 ft (Includes items 21)	1
	S62050	Walking Beam - 61 ft to 71 ft with optional 16.5L tires (Includes items 21)	1
	S62050	Walking Beam - 80 ft to 90 ft (Includes items 21)	1
24	W-495	Hex Bolt - 1/2 x 4 Lg.....	2
25	W-4181	Cotter Pin - 1/4 x 2 Lg	2

Main Dual Wheels Front Axle Castor - 41 Ft to 90 Ft - Prior to 2018

Note: It is recommended to convert to the 2018 greaseable axle. Refer to Tech Bulletin 456 for more details.

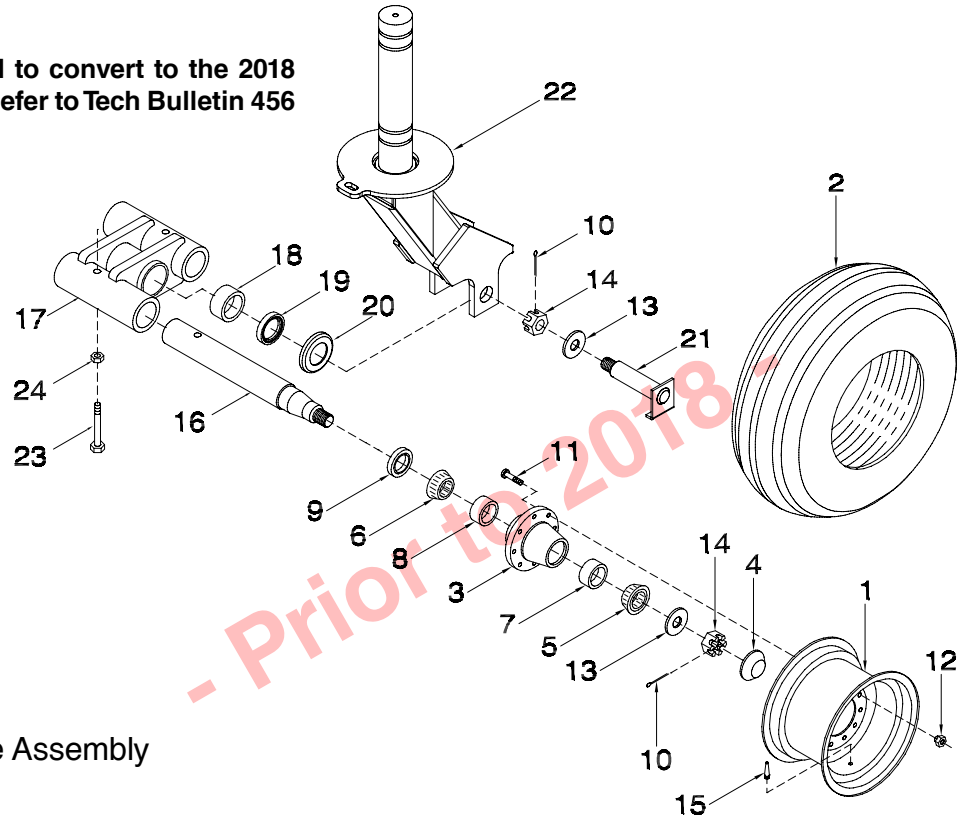

Quantities are per Axle Assembly

Item	Part No.	Description	Qty
1	C17355	Rim - 15 x 10 - 8 Bolt - 41 ft to 71 ft Models	2
	S47512	Rim - 16.1 x 14 - 8 Bolt - 80 to 90 ft Models	2
2	C16609	Tire - 11L x 15FI - Load Range F - 41 ft & 51 ft Models	2
	C26840	Tire - 12.5L x 15FI - Load Range F - 61 ft & 71 ft Models	2
	S47510	Tire - 16.5L x 16.1FI - Load Range E - 80 to 90 ft Models (61 & 71 optional)	2
3	N19173	Hub (Includes Items 7, 8 & 11)	2
4	N19171	Dust Cap	2
5	N19170	Outer Wheel Bearing	2
6	N19169	Inner Wheel Bearing	2
7	N19168	Outer Bearing Cup	2
8	N19167	Inner Bearing Cup	2
9	N19172	Seal	2
10	D-5239	Cotter Pin - 1/4 x 2 1/4	2
11	N19727	Wheel Stud - 5/8-18 UNF x 2 1/2	16
12	N19586	Tapered Wheel Nut - 5/8-18 UNF	16
13	N13962	Flatwasher - 1 9/32 ID x 2 1/2 OD x 1/4 thick	3
14	N19484	Castle Nut - 1 1/4	3
15	C17348	Valve Stem - TR-416	2
16	S32556	Spindle - 2 1/2 Dia - 41 to 71 ft Models	2
	S47509	Spindle - 2 1/2 Dia - 80 to 90 ft Models (61 & 71 with optional Tire)	2
17	S39991	Axle Bracket - Offset - 2 1/2 Spindle (Includes items 18 & 19) - 41 ft to 71 ft Models	1
	S47629	HD Axle Bracket - Offset - 2 1/2 Spindle (Includes items 18 & 19) - 61 & 71 optional Tire	1
	S47629	Axle Bracket - Offset - 2 1/2 Spindle (Includes items 18 & 19) - 80 to 90 ft Models	1
18	C26086	Bearing - Garlock - 1 3/4 OD x 1 1/2 Lg	2
19	C26266	Dust Seal - 2.254 OD x 0.266 Thick	2
20	C26082	Washer - Formed - 1 3/4 ID	2
21	S47627	Pin - Walking Beam Pivot - 1 3/4 x 6 1/2 UL	1
22	S44309	Castor Fork - 41 to 71	1
	S53265	Castor Fork - 61 & 71 with optional 16.5L tires	1
	S53265	Castor Fork - 80 to 90	1
23	W-495	Hex Bolt - 1/2 x 4 Lg	2
24	F-3405	Locknut - 1/2 Unitorque	2

Main Dual Wheels Rear Axles - 41 Ft to 90 Ft - 2018 to Present

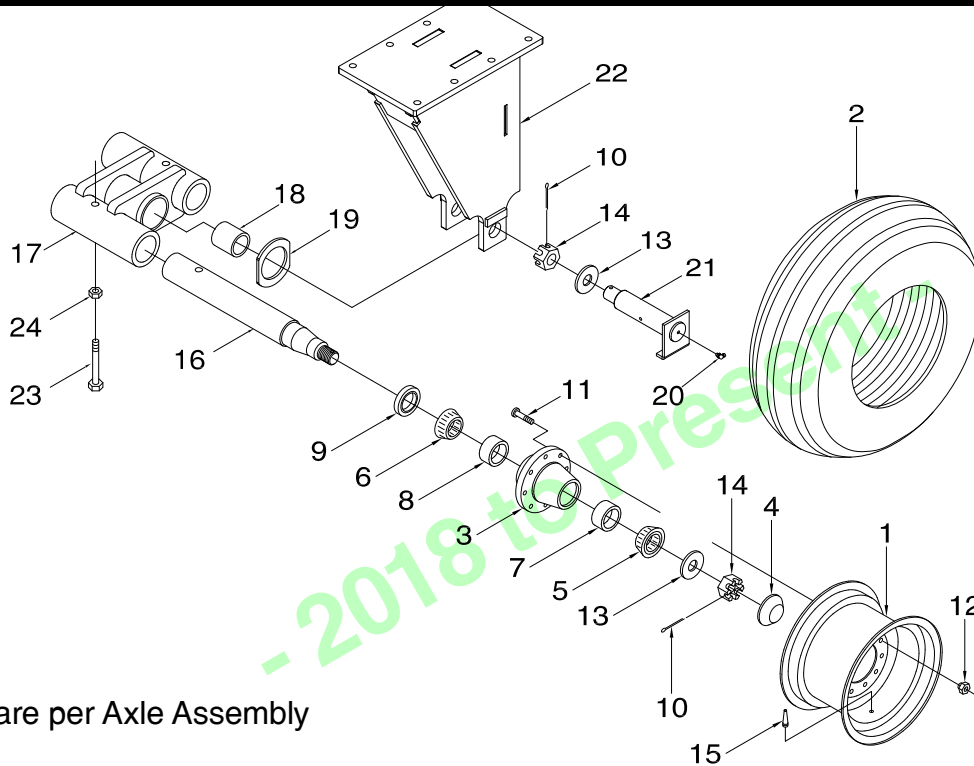

Quantities are per Axle Assembly

Item	Part No.	Description	Qty
1	C17355	Rim - 15 x 10 - 8 Bolt - 41 ft to 71 ft Models	2
	S47512	Rim - 16.1 x 14 - 8 Bolt - 80 ft to 90 ft Models (61 & 71 with optional 16.5L tires).....	2
2	C16609	Tire - 11L x 15FI - Load Range F - 41 ft & 51 ft Models	2
	C26840	Tire - 12.5L x 15FI - Load Range F - 61 ft & 71 ft Models	2
	S47510	Tire - 16.5L x 16.1FI - Load Range E - 80 ft to 90 ft Models (61 & 71 optional)	2
3	N19173	Hub (Includes Items 7, 8 & 11).....	2
4	N19171	Dust Cap	2
5	N19170	Outer Wheel Bearing.....	2
6	N19169	Inner Wheel Bearing	2
7	N19168	Outer Bearing Cup	2
8	N19167	Inner Bearing Cup.....	2
9	N19172	Seal.....	2
10	D-5239	Cotter Pin - 1/4 x 2 1/4 Lg	3
11	N19727	Wheel Stud - 5/8 x 18 UNF x 2 1/2 Lg	16
12	N19586	Tapered Wheel Nut - 5/8 - 18 UNF	16
13	N13962	Flatwasher - 1.281 ID x 2 1/2 OD x 1/4 Thick.....	3
14	N19484	Hex Slotted Nut - 1-1/4 - 12 UNF.....	3
15	C17348	Valve Stem - TR-416.....	2
16	S32556	Spindle - 2 1/2 Dia - 41 ft to 71 ft Models	2
	S47509	Spindle - 2 1/2 Dia - 80 ft to 90 ft Models (61 ft & 71 ft with optional 16.5L tires).....	2
17	S62085	Walking Beam - 41 ft to 71 ft (Includes items 18)	1
	S62050	Walking Beam - 61 ft to 71 ft with optional 16.5L tires (Includes items 18)	1
	S62050	Walking Beam - 80 ft to 90 ft (Includes items 18)	1
18	S62027	Axle Pivot Bushing - 1.75 ID x 2.25 OD x 1.875Lg (Used in S62085)	2
	S55639	Axle Pivot Bushing - 1.75 ID x 2.25 OD x 2.375Lg (Used in S62050).....	2
19	S55629	Wear Washer - only used on the S62050 walking beam	2
20	F-3056	Grease Zerk - 1/4 NPT 90 degree.....	1
21	S62026	Pivot Pin - Greasable - 1 3/4 Dia x 6 1/2 UL (Includes item 20).....	1
22	S42900	Rear Main Axle - Standard - 26 3/4 Lg - 41 to 71 - Prior to Sept. 2012	1
	S51020	Rear Main Axle - Standard - 26 3/4 Lg - 41 to 71.....	1
	S47080	Rear Main Axle - 80 ft to 90 ft (61 & 71 with optional 16.5L tires) - Prior to Sept. 2013.....	1
	S53264	Rear Main Axle - 80 ft to 90 ft (61 & 71 with optional 16.5L tires)	1
23	W-495	Hex Bolt - 1/2 x 4 Lg.....	2
24	F-3405	Locknut - 1/2 Unitorque.....	2

Main Dual Wheels Rear Axles - 41 Ft to 90 Ft - Prior to 2018

Note: It is recommended to convert to the 2018 greaseable axle. Refer to Tech Bulletin 456 for more details.

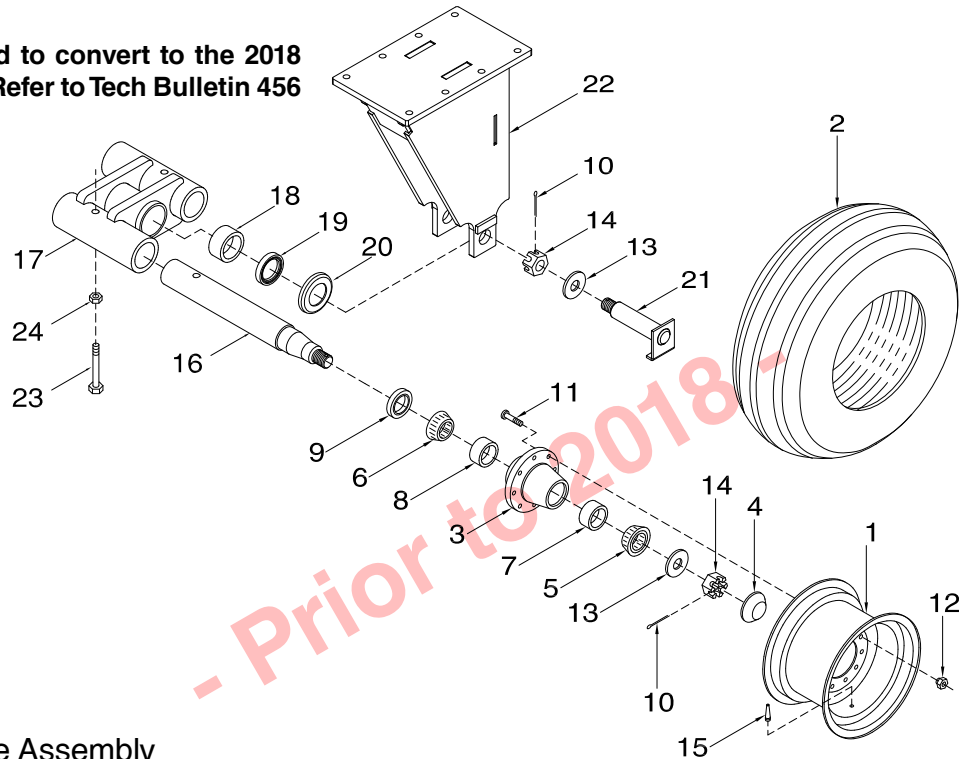

Quantities are per Axle Assembly

Item	Part No.	Description	Qty
1	C17355	Rim - 15 x 10 - 8 Bolt - 41 ft to 71 ft Models	2
	S47512	Rim - 16.1 x 14 - 8 Bolt - 80 to 90 ft Models	2
2	C16609	Tire - 11L x 15FI - Load Range F - 41 ft & 51 ft Models	2
	C26840	Tire - 12.5L x 15FI - Load Range F - 61 ft & 71 ft Models	2
	S47510	Tire - 16.5L x 16.1FI - Load Range E - 80 to 90 ft Models (61 & 71 optional)	2
3	N19173	Hub (Includes Items 7, 8 & 11)	2
4	N19171	Dust Cap	2
5	N19170	Outer Wheel Bearing	2
6	N19169	Inner Wheel Bearing	2
7	N19168	Outer Bearing Cup	2
8	N19167	Inner Bearing Cup	2
9	N19172	Seal	2
10	D-5239	Cotter Pin - 1/4 x 2 1/4	3
11	N19727	Wheel Stud - 5/8-18 UNF x 2 1/2	16
12	N19586	Tapered Wheel Nut - 5/8-18 UNF	16
13	N13962	Flatwasher - 1.281ID x 2 1/2 OD x 1/4 Thick	3
14	N19484	Castle Nut - 1 1/4	3
15	C17348	Valve Stem - TR-416	2
16	S32556	Spindle - 2 1/2 Dia - 41 to 71 ft Models	2
	S47509	Spindle - 2 1/2 Dia - 80 to 90 ft Models (61 & 71 with optional Tire)	2
17	S39991	Axle Bracket - Offset - 2 1/2 Spindle (Includes items 18 & 19) - 41 to 71 Models	1
	S47629	HD Axle Bracket - Offset - 2 1/2 Spindle (Includes items 18 & 19) - 61 & 71 optional Tire	1
	S47629	HD Axle Bracket - Offset - 2 1/2 Spindle (Includes items 18 & 19) - 80 to 90 ft Models	1
18	C26086	Bearing - Garlock - 1 3/4 OD x 1 1/2 Lg	2
19	C26266	Dust Seal - 2.254 OD x 0.266 Thick	2
20	C26082	Washer - Formed - 1 3/4 ID	2
21	S47627	Pin - Walking Beam Pivot - 1 3/4 x 6 1/2 UL	1
22	S42900	Rear Main Axle - Standard - 26 3/4 Lg - 41 to 71 - Prior to Sept. 2012	1
	S51020	Rear Main Axle - Standard - 26 3/4 Lg - 41 to 71	1
	S47080	Rear Main Axle - 80 to 90 (61 & 71 with optional 16.5L tires) - Prior to Sept. 2013	1
	S53264	Rear Main Axle - 80 to 90 (61 & 71 with optional 16.5L tires)	1
23	W-495	Hex Bolt - 1/2 x 4 Lg	2
24	F-3405	Locknut - 1/2 Unitorque	2

Main Single Wheels Front Axle Castor - 25 and 31 Ft

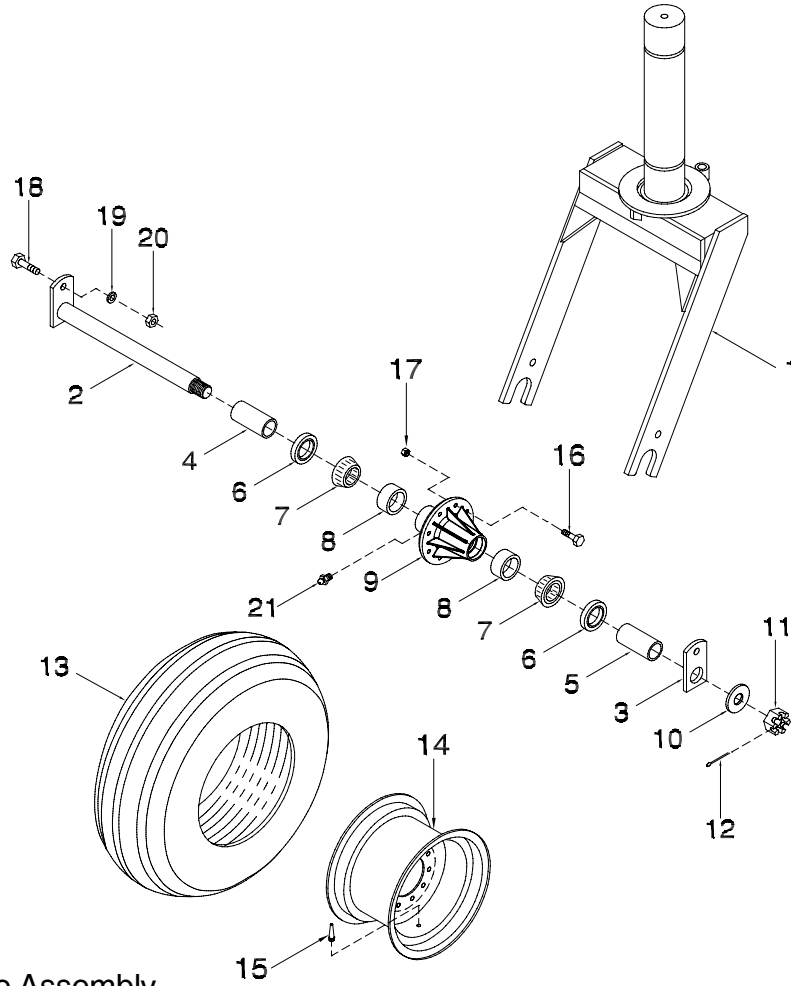

Quantities are per Axle Assembly

Item	Part No.	Description	Qty
1	S44965	Castor Fork - HD Single	1
2	S45254	Spindle - HD 1.75	1
3	S45257	Plate	1
4	S45258	Spacer - 1.76 ID x 2 1/4 OD x 3 7/8 Lg	1
5	S45278	Spacer - 1.76 ID x 2 1/4 OD x 3 3/16 Lg.....	1
6	S45262	Hub Seal	2
7	S45261	Bearing Cone	2
8	S45260	Bearing Cup - LM25520.....	2
9	S45259	Hub - 8 Bolt (Includes Items 8, 16 & 21)	1
10	N13962	Flatwasher - 1.281 ID x 2.5 OD x 9 Ga	1
11	N19484	Slotted Nut - 1.25-12UNF	1
12	D-5239	Cotter Pin - 1/4 x 2 1/4	1
13	C26840	Tire - 12.5L x 15FI - Load Range F	1
14	C17355	Rim - 15 x 10 - 8 Bolt.....	1
15	C17348	Valve Stem - TR-416.....	1
16	N19727	Wheel Stud Bolt - 5/8 x 2	8
17	N19586	Tapered Wheel Nut - 5/8-18 UNF	8
18	W-498	Hex Bolt - 5/8 x 1 3/4.....	2
19	W-526	Lockwasher - 5/8.....	2
20	W-517	Hex Nut - 5/8	2
21	F-3009	Grease Zerk - 1/4-28 NF x 45 degree.....	1

Main Single Wheels Rear Axle - 25 and 31 Ft

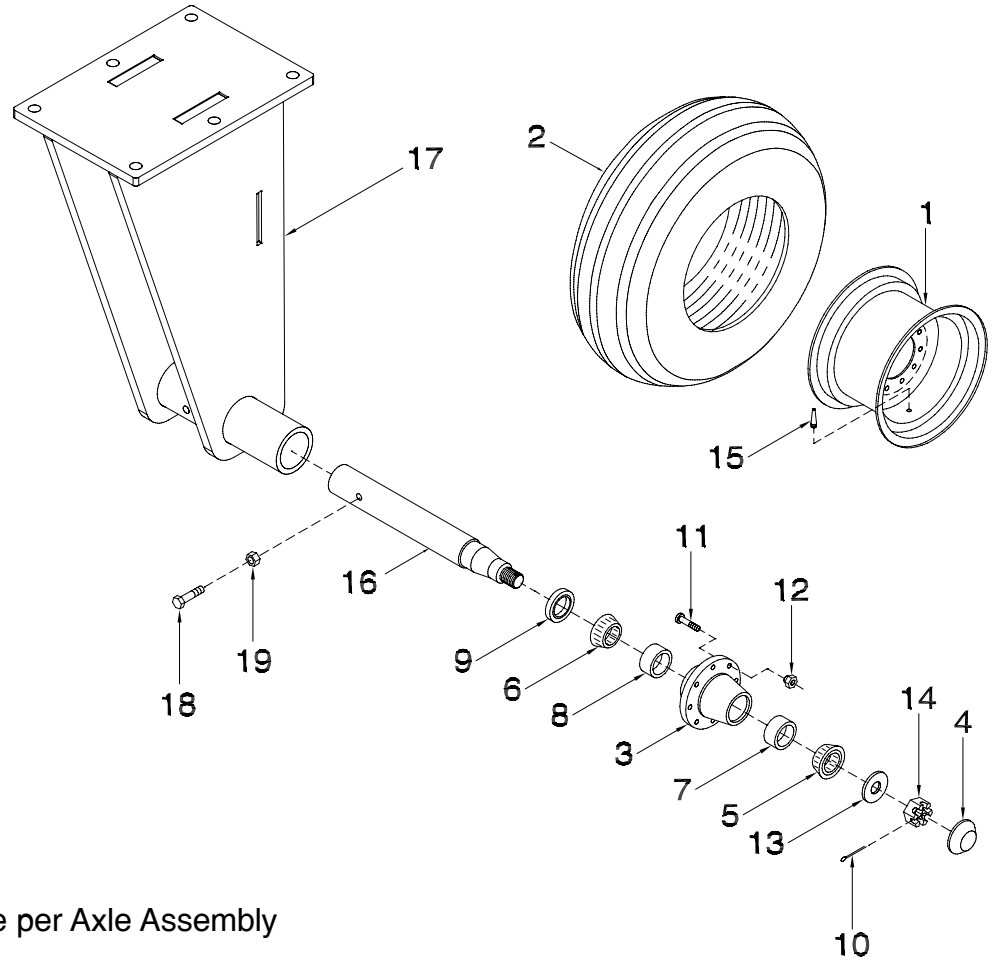

Quantities are per Axle Assembly

Item	Part No.	Description	Qty
1	C17355	Rim - 15 x 10 - 8 Bolt.....	1
2	C26840	Tire - 12.5L x 15FI - Load Range F.....	1
3	N19173	Hub (Includes Items 7, 8 & 11).....	1
4	N19171	Dust Cap.....	1
5	N19170	Outer Wheel Bearing.....	1
6	N19169	Inner Wheel Bearing.....	1
7	N19168	Outer Bearing Cup.....	1
8	N19167	Inner Bearing Cup.....	1
9	N19172	Seal.....	1
10	D-5239	Cotter Pin - 1/4 x 2 1/4.....	1
11	N19727	Wheel Stud - 5/8-18 UNF x 2 1/2.....	8
12	N19586	Tapered Wheel Nut - 5/8-18 UNF.....	8
13	N13962	Flatwasher.....	1
14	N19484	Castle Nut - 1 1/4.....	1
15	C17348	Valve Stem - TR-416.....	1
16	S32556	Spindle - 2 1/2 Dia.....	1
17	S44962	Rear Axle Bracket - Left - Prior to Sept. 2012.....	1
	S51013	Rear Axle Bracket - Left.....	1
17A	S44963	Rear Axle Bracket - Right (Not Shown) - Prior to Sept. 2012.....	1
	S51014	Rear Axle Bracket - Right (Not Shown).....	1
18	W-495	Hex Bolt - 1/2 x 4 Lg.....	1
19	F-3405	Locknut - 1/2 Unitorque.....	1

Wing Dual Wheels Front Axle Castor - 41 Ft to 90 Ft - 2018 to Present

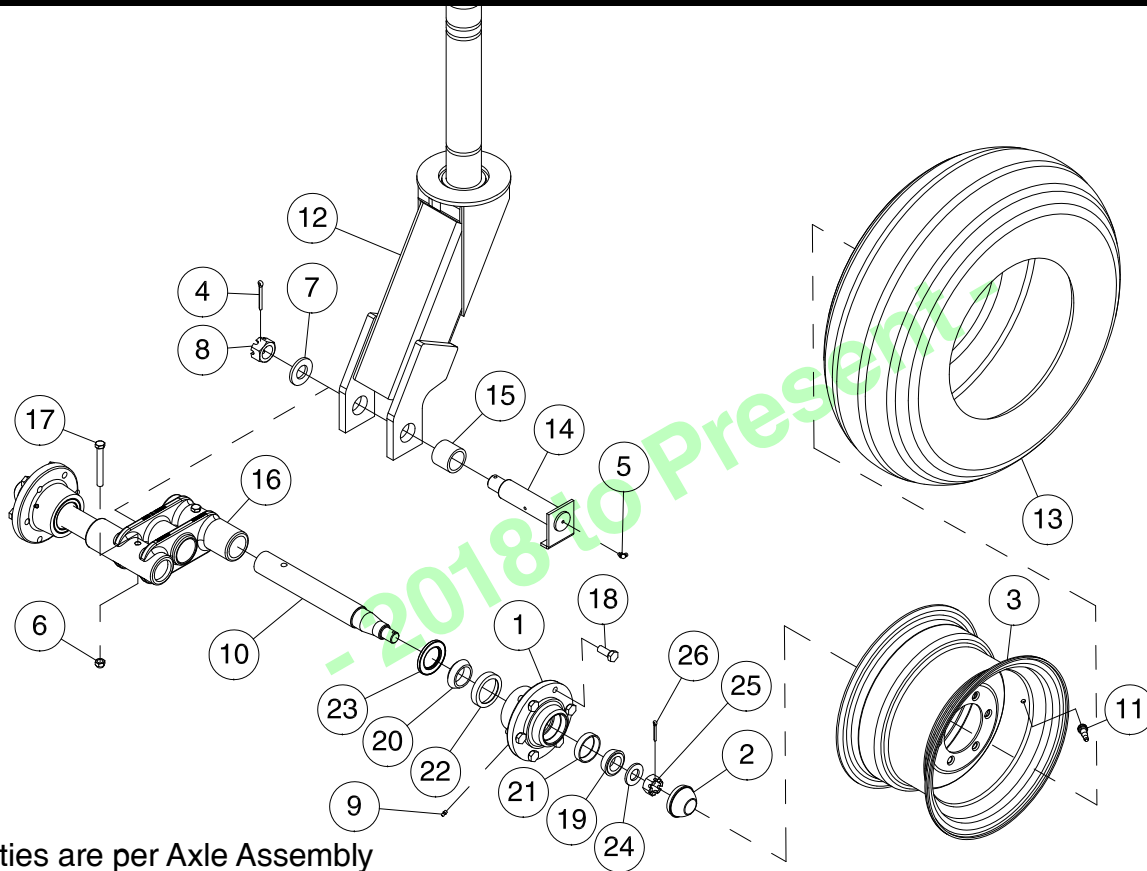

Quantities are per Axle Assembly

Item	Part No.	Description	Qty
1	S72399	Heavy Duty Hub - 6 Bolt (Include Items 9, 21 & 22) (C-1463)	2
2	C-1522	Dust Cap	2
3	C16611	Rim - 15 x 10 - 6 Hole	2
4	D-5239	Cotter Pin - 1/4 x 2 1/4 Lg	1
5	F-3056	Grease Zerk - 1/4 NPT 90 degree.....	1
6	F-3405	Locknut - 1/2 Unitorque.....	2
7	N13962	Washer - 2-1/2 OD x 1-9/32 ID x 1/4	1
8	N19484	Hex Slotted Nut - 1-1/4 - 12 UNF.....	1
9	S-752	Grease Zerk - 1/4 UNF Straight	2
10	S32545	Spindle 2" Dia.....	2
11	W-3328	Valve Stem - TR-415 - 41 ft & 51 ft Models	2
	C17348	Valve Stem - TR-416 - 5 Frame Models.....	2
12	S45720	Offset Castor - 3/4" Side Plates	1
13	S47557	Tire - 11L x 15SL - 12 Ply Rating - 41 ft & 51 ft Models.....	2
	C24562	Tire - 12.5L x 15SL - 12 Ply Rating - 5 Frame Models.....	2
14	S62026	Pivot Pin - Greasable - 1 3/4 Dia x 6 1/2 UL (Includes item 5).....	1
15	S62027	Axle Pivot Bushing - 1.75 ID x 2.25 OD x 1.875 Lg	2
16	S62055	Offset Castor - Includes item 15.....	1
17	W-495	Hex Bolt - 1/2 x 4 Lg.....	2
18	W-1383	Wheel Stud Bolt - 9/16 x 1 3/16 UL.....	12
19	W-1474	Outer Wheel Bearing	2
20	W-1475	Inner Wheel Bearing	2
21	W-1537	Outer Bearing Cup	2
22	W-1538	Inner Bearing Cup	2
23	C-1521	Dust Seal	2
24	C-3258	Flatwasher - 2 OD x 1 1/16 ID x 3/16.....	2
25	S-1311	Slotted Nut - 1 UNS.....	2
26	W-1416	Cotter Pin - 3/16 x 1 1/2 Lg	2
	S63946	Kit: Walking Axle Overhaul for 11L and 12.5L Tire (Includes items 4, 7, 8, 14 and 15)	

Wing Dual Wheels Front Axle Castor - 41 Ft to 90 Ft - Prior to 2018

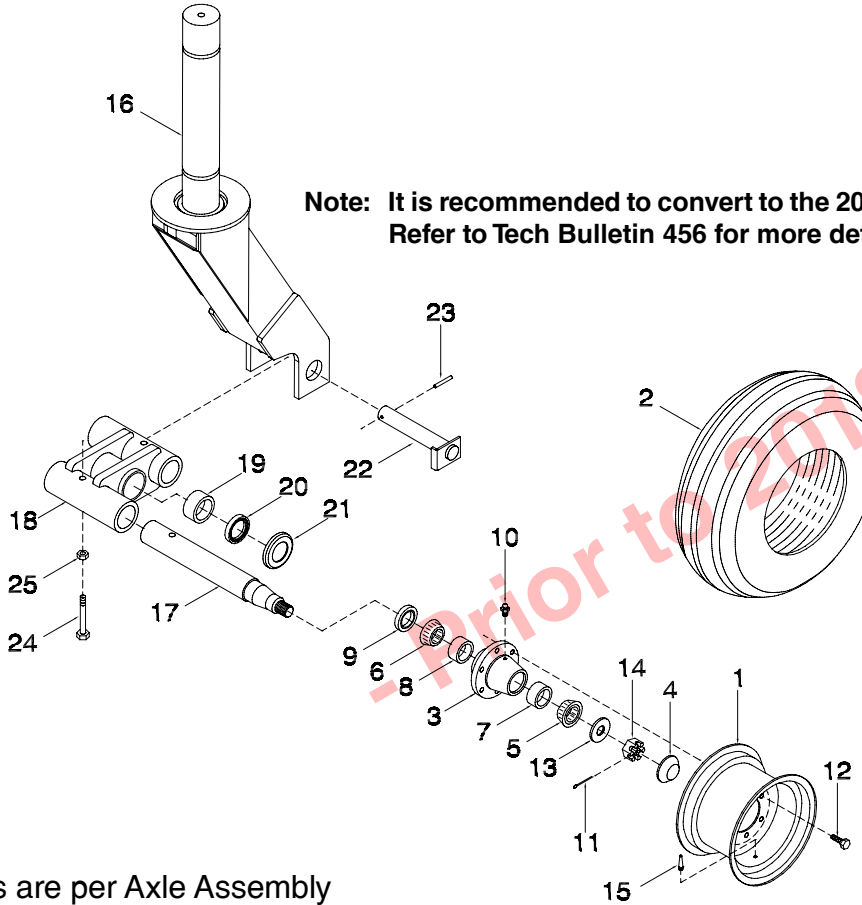

Quantities are per Axle Assembly

Item	Part No.	Description	Qty
1	C16611	Rim - 15 x 10 - 6 Bolt.....	2
2	S47557	Tire - 11L x 15SL - 12 Ply rating - 41 & 51 ft Models	2
	C24562	Tire - 12.5L x 15SL - 12 Ply rating - 5 Frame Models	2
3	S72399	Heavy Duty Hub - 6 Bolt (Includes Items 7, 8 & 10) (C-1463)	2
4	C-1522	Dust Cap	2
5	W-1474	Outer Wheel Bearing.....	2
6	W-1475	Inner Wheel Bearing	2
7	W-1537	Outer Bearing Cup	2
8	W-1538	Inner Bearing Cup	2
9	C-1521	Seal.....	2
10	S-752	Grease Zerk - 1/4 NPT Straight	2
11	W-1416	Cotter Pin - 3/16 x 1 1/2	2
12	W-1383	Wheel Stud Bolt - 9/16 x 1 11/16	12
13	C-3258	Flatwasher - 2 OD x 1 1/16 ID x 3/16	2
14	S-1311	Slotted Nut - 1	2
15	W-3328	Valve Stem - TR-415 - 41 & 51 ft Models	2
	C17348	Valve Stem - TR-416 - 5 Frame Models.....	2
16	S45720	Offset Castor - 3/4" side plates	1
17	S32545	Spindle 2" Dia	2
18	S39440	Axle Bracket - Offset (Includes items 19 & 20)	1
19	C26086	Bearing - Garlock - 1 3/4 OD x 1 1/2 Lg	2
20	C26266	Dust Seal - 2.54 OD x 0.266 Thick	2
21	C26082	Washer - Formed - 1 3/4 ID	2
22	C26085	Pin - Walking Beam Pivot - 1 3/4 x 6 5/8 UL	4
23	T-5245	Spiral Pin - 3/8 x 2 1/2.....	1
24	W-493	Hex Bolt - 1/2 x 3 1/2 Lg.....	2
25	F-3405	Locknut - 1/2 Unitorque.....	2

Wing Dual Wheels Rear Axle - 80 to 90 Ft - 2018 to Present

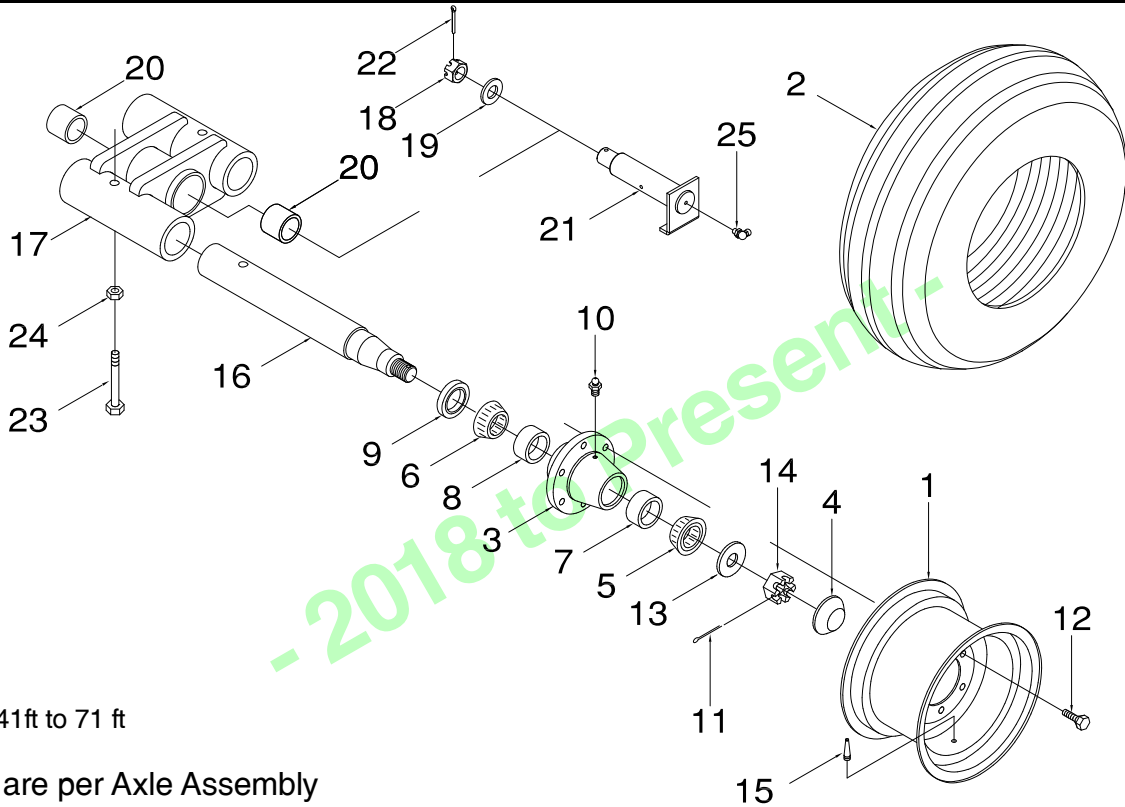

Optional for 41ft to 71 ft

Quantities are per Axle Assembly

Item	Part No.	Description	Qty
1	C16611	Rim - 15 x 10 - 6 Bolt.....	2
2	S47557	Tire - 11L x 15SL - 12 Ply rating - 41 ft & 51 ft Models	2
	C24562	Tire - 12.5L x 15SL - 12 Ply rating - 5 Frame Models	2
3	S72399	Heavy Duty Hub - 6 Bolt (Includes Items 7, 8 & 10) (C-1463)	2
4	C-1522	Dust Cap	2
5	W-1474	Outer Wheel Bearing.....	2
6	W-1475	Inner Wheel Bearing	2
7	W-1537	Outer Bearing Cup	2
8	W-1538	Inner Bearing Cup.....	2
9	C-1521	Seal.....	2
10	S-752	Grease Zerk - 1/4 NPT Straight	2
11	W-1416	Cotter Pin - 3/16 x 1 1/2 Lg	2
12	W-1383	Wheel Stud Bolt - 9/16 x 1 11/16 Lg	12
13	C-3258	Flatwasher - 2 OD x 1 1/16 ID x 3/16	2
14	S-1311	Slotted Nut - 1 SAE	2
15	W-3328	Valve Stem - TR-415 - 41 ft & 51 ft Models.....	2
	C17348	Valve Stem - TR-416 - 5 Frame Models.....	2
16	S32545	Spindle 2" Dia	2
17	S62055	Axle Bracket - Offset (Includes items 20)	1
18	N19484	Hex Slotted Nut - 1-1/4 - 12 UNF.....	1
19	N13962	Washer - 2-1/2 OD x 1-9/32 ID x 1/4	1
20	S62027	Axle Pivot Bushing - 1.75 ID x 2.25 OD x 1.875Lg	2
21	S62026	Pivot Pin - Greasable - 1 3/4 Dia x 6 1/2 UL (Includes item 25).....	1
22	D-5239	Cotter Pin - 1/4 x 2 1/4 Lg	1
23	W-493	Hex Bolt - 1/2 x 3 1/2 Lg.....	2
24	F-3405	Locknut - 1/2 Unitorque.....	2
25	F-3056	Grease Zerk - 1/4 NPT 90 degree.....	1
	S63946	Kit: Walking Axle Overhaul for 11L and 12.5L Tire (Includes items 18, 19, 20, 21 and 22)	

Wing Dual Wheels Rear Axle - 80 to 90 Ft - Prior to 2018

Note: It is recommended to convert to the 2018 greaseable axle.
Refer to Tech Bulletin 456 for more details.

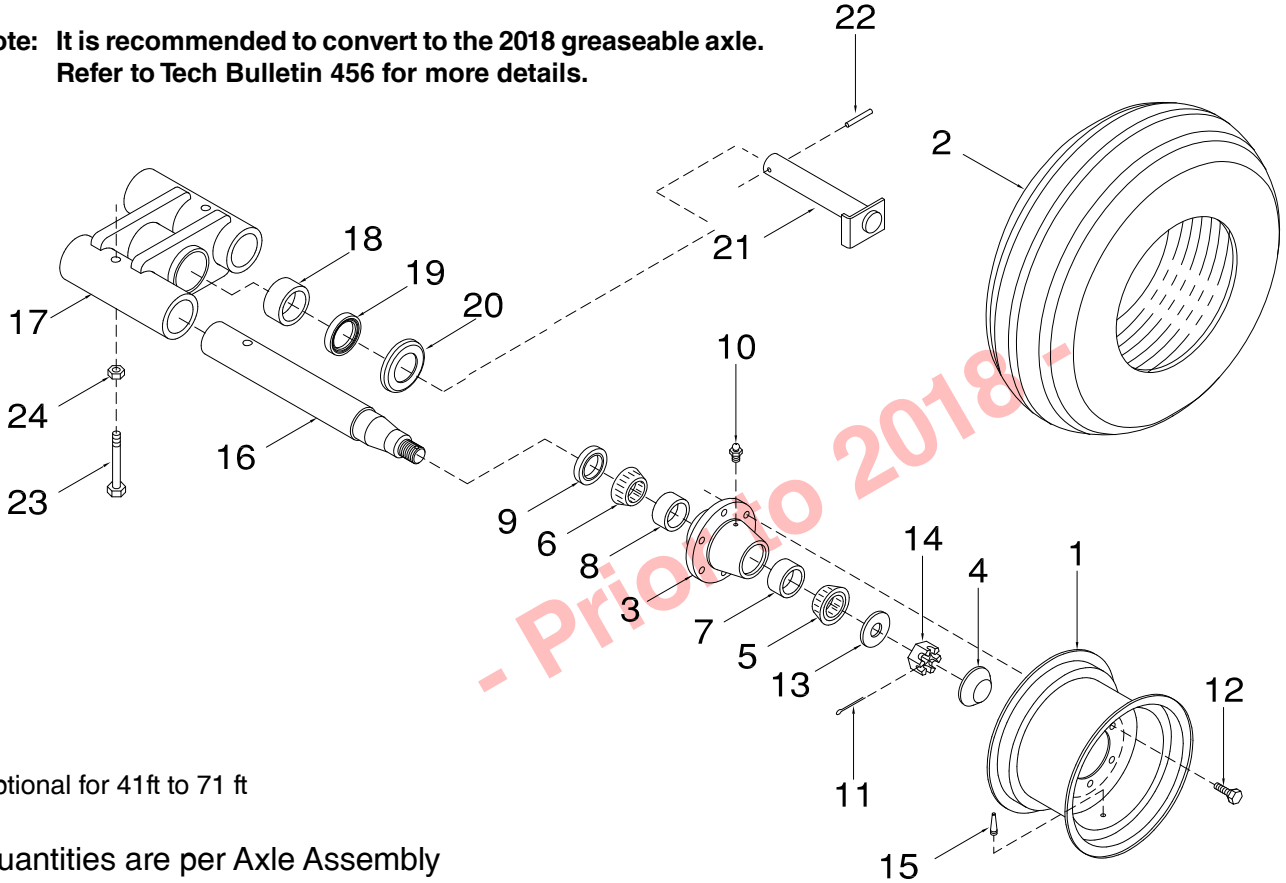

Optional for 41ft to 71 ft

Quantities are per Axle Assembly

Item	Part No.	Description	Qty
1	C16611	Rim - 15 x 10 - 6 Bolt.....	2
2	S47557	Tire - 11L x 15SL - 12 Ply rating - 41 & 51 ft Models	2
	C24562	Tire - 12.5L x 15SL - 12 Ply rating - 5 Frame Models	2
3	S72399	Heavy Duty Hub - 6 Bolt (Includes Items 7, 8 & 10) (C-1463)	2
4	C-1522	Dust Cap	2
5	W-1474	Outer Wheel Bearing.....	2
6	W-1475	Inner Wheel Bearing	2
7	W-1537	Outer Bearing Cup	2
8	W-1538	Inner Bearing Cup	2
9	C-1521	Seal.....	2
10	S-752	Grease Zerk - 1/4 NPT Straight	2
11	W-1416	Cotter Pin - 3/16 x 1 1/2	2
12	W-1383	Wheel Stud Bolt - 9/16 x 1 11/16	12
13	C-3258	Flatwasher - 2 OD x 1 1/16 ID x 3/16	2
14	S-1311	Slotted Nut - 1 SAE	2
15	W-3328	Valve Stem - TR-415 - 41 & 51 ft Models	2
	C17348	Valve Stem - TR-416 - 5 Frame Models.....	2
16	S32545	Spindle 2" Dia	2
17	S39440	Axle Bracket - Offset (Includes items 18 & 19)	1
18	C26086	Bearing - Garlock - 1 3/4 OD x 1 1/2 Lg	2
19	C26266	Dust Seal - 2.54 OD x 0.266 Thick	2
20	C26082	Washer - Formed - 1 3/4 ID	2
21	C26085	Pin - Walking Beam Pivot - 1 3/4 x 6 5/8 UL	4
22	T-5245	Spiral Pin - 3/8 x 2 1/2.....	1
23	W-493	Hex Bolt - 1/2 x 3 1/2 Lg.....	2
24	F-3405	Locknut - 1/2 Unitorque.....	2

Wing Single Wheels Front Axle Castor - 25 Ft and 31 Ft

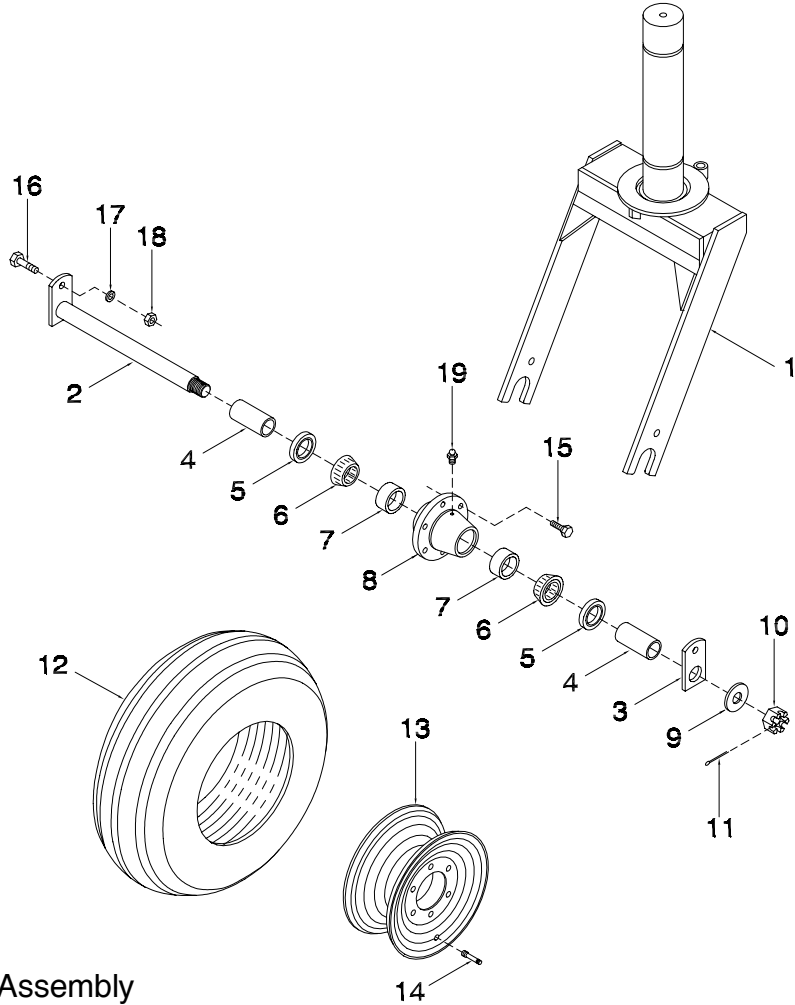

Quantities are per Axle Assembly

Item	Part No.	Description	Qty
1	C18657	Castor Fork - 3"	1
2	N19164	Spindle	1
3	D-4947	Plate	1
4	N19165	Spacer	2
5	D-5402	Hub Seal	2
6	W-1474	Bearing Cone	2
7	W-1537	Bearing Cup	2
8	D-4837	Hub - 6 Bolt (Includes Items 7 & 19)	1
9	D-5498	Flatwasher - 1	1
10	S-1311	Slotted Nut - 1	1
11	D-5238	Cotter Pin - 3/16 x 1 3/4	1
12	S47557	Tire - 11L x 15SL - 12 Ply rating - 41 & 51 ft Models	1
	C24562	Tire - 12.5L x 15SL - 12 Ply rating - 25 ft, 31 ft Model & 5 Frame Models	1
13	C16611	Rim - 15 x 10 - 6 Bolt	1
14	W-3328	Valve Stem - TR-415 - 41 & 51 ft Models	1
	C17348	Valve Stem - TR-416 - 31 ft Models & 5 Frame Models	1
15	W-1383	Wheel Stud Bolt - 9/16 x 1 11/16	6
16	W-498	Hex Bolt - 5/8 x 1 3/4	2
17	W-526	Lockwasher - 5/8	2
18	W-517	Hex Nut - 5/8	2
19	S-752	Grease Zerk - 1/4 NPT Straight	1

Wing Single Wheels Rear Axle - 25 Ft to 71 Ft

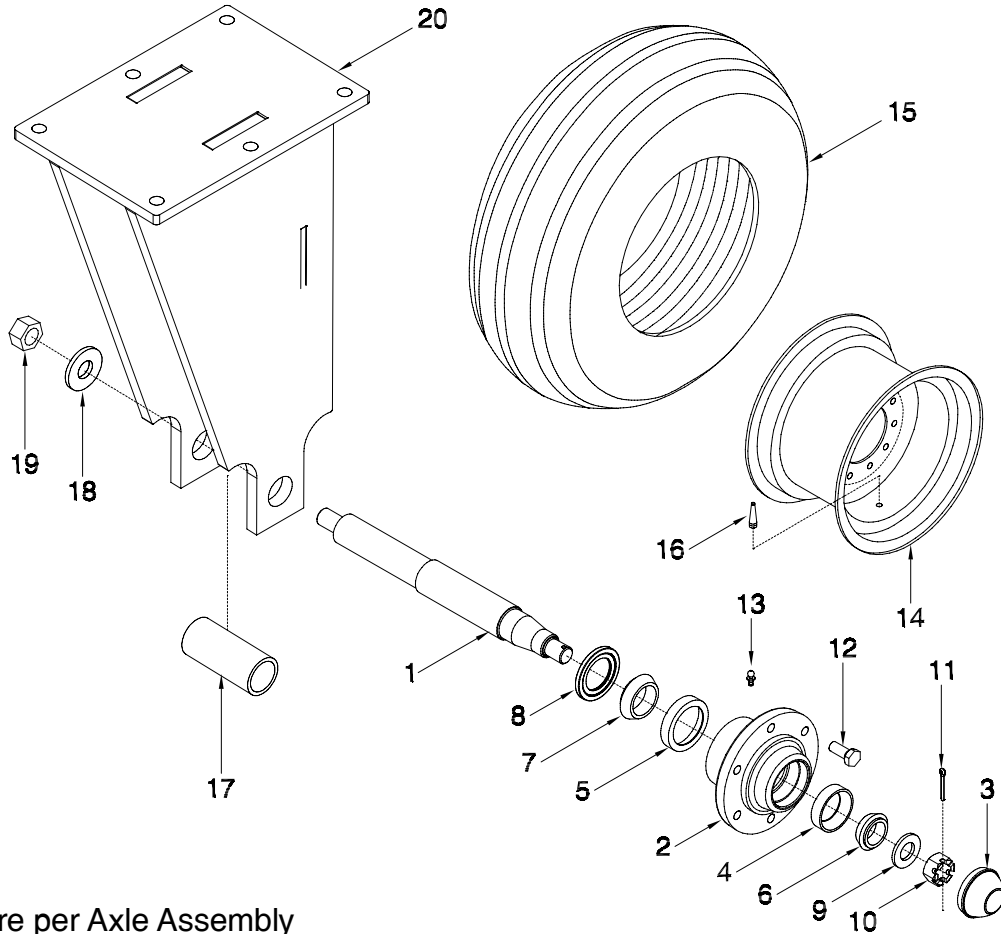

Quantities are per Axle Assembly

Item	Part No.	Description	Qty
1	N33998	Spindle.....	1
2	S72399	Heavy Duty Hub - 6 Bolt (Includes Items 4, 5 & 13) (C-1463).....	1
3	C-1522	Dust Cap	1
4	W-1537	Outer Bearing Cup.....	1
5	W-1538	Inner Bearing Cup.....	1
6	W-1474	Outer Wheel Bearing	1
7	W-1475	Inner Wheel Bearing	1
8	C-1521	Dust Seal	1
9	C-3258	Flatwasher - 2 OD x 1 1/16 ID x 3/16.....	1
10	S-1311	Slotted Nut - 1	1
11	W-1416	Cotter Pin - 3/16 x 1 1/2 Lg	1
12	W-1383	Wheel Stud Bolt - 9/16 x 1 11/16 Lg.....	6
13	S-752	Grease Zerk - 1/4 NPT Straight	1
14	C16611	Rim - 15 x 10 - 6 Bolt.....	1
15	S47557	Tire - 11L x 15SL - 12 Ply rating - 41 & 51 ft Models.....	1
	C24562	Tire - 12.5L x 15SL - 12 Ply rating - 25 ft, 31 ft Model & 5 Frame Models	1
16	W-3328	Valve Stem - TR-415 - 41 & 51 ft Models	1
	C17348	Valve Stem - TR-416 - 25 ft, 31 ft Models & 5 Frame Models.....	1
17	S42986	Spacer - 1.812 ID x 2.25 OD x 5 LG.....	1
18	C12375	Flatwasher - 1 1/16 ID x 2 1/2 OD x 1/4 Thick.....	1
19	D-5274	Locknut - 1	1
20	S47084	Rear Axle Wing Depth Beams - Prior to Sept. 2012	1
	S51025	Rear Axle Wing Depth Beams.....	1

Section 3: Opener

Section Contents

Opener Assembly	3-2
Prior to 2020	3-2
2020 to 2021	3-4
Cast - 2022 to Present.....	3-6
Body Assembly	3-8
Prior to 2016	3-8
2016 to 2019	3-10
2020 to 2021	3-12
Cast - 2022 to Present.....	3-14
Packer Arm Assembly	3-16
Prior to 2020	3-16
Adjustable - Prior to 2020	3-17
Welded - 2020 to 2021	3-18
Cast - 2022 to Present.....	3-19
Packer Wheel Assemblies	3-20
Seed Boot.....	3-21
Injected Polymer Pair Row Kit	3-21
Injected Polymer Left Sideband Kit	3-22
Injected Polymer Right Side Band Kit	3-23
Single Shoot.....	3-24
Single Shoot 3" Spreader	3-25
Double Shoot - Paired Row	3-26
Double Shoot - High Pressure NH3 Kit	3-27
Double Shoot - Side Band - Left	3-28
Double Shoot - Side Band Boot - Right	3-29
Soil Levelers	3-30

Opener Assembly Prior to 2020

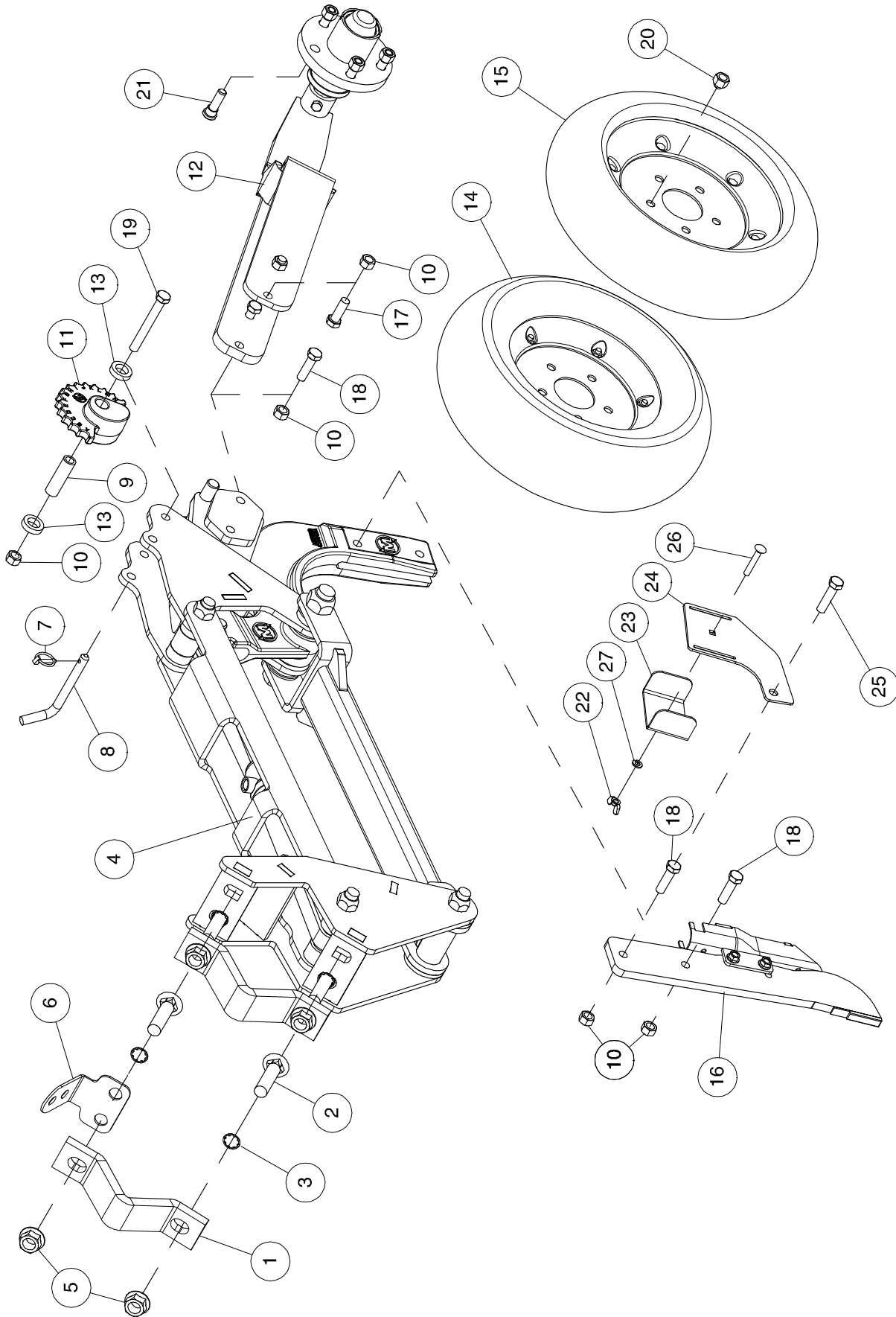

Opener Assembly - Prior to 2020

Item	Part No.	Description	Qty
1	C26506	Clamp Strap	2
2	C33957	Carriage Bolt - 3/4 x 3 Lg	4
3	C33958	Retaining Ring	4
4	S59800	Base Assembly - See Page 3-8	1
5	D12942	Serrated Flange Lock Nut - 3/4	4
6	S47976	Hose Holder	1
7	S42294	Lynch Pin - 3/16 Dia x 1/14 Lg	1
8	S42659	Depth Pin - 1/2 Dia x 3 1/2 UL	1
9	S44402	Bushing - 0.510 ID x 0.750 OD x 2 9/16 Lg.....	1
10	S47110	Center Lock Hex Nut - 1/2	7
11	S49260	Depth Adjustment Cam	1
12	S49500	Packer Arm Assembly	1
13	S49516	Spacer Washer - 25/32 ID x 1 1/4 OD x 5/16 thick.....	2
14	S64195	Otico Tire - 5 1/2	1
15	S64194	Otico Tire - 4 1/2	1
16	S65121	Right Sideband Boot Kit - SHIELD CORE	1
	S65122	Left Sideband Boot Kit - SHIELD CORE	
	S65123	Paired Row Boot Kit - SHIELD CORE	
	*****	Single Shoot Boot Kit - SHIELD CORE	
17	W-486	Hex Bolt - 1/2 x 1 1/2 Lg.....	2
18	W-487	Hex Bolt - 1/2 x 1 3/4 Lg.....	4
19	W-495	Hex Bolt - 1/2 x 4 Lg.....	1
20	S50246	Tapered Wheel Nut - 1/2-20 UNF	5
21	S50247	Press-In Wheel Stud - 1/2-20 UNF x 1 3/4 Lg.....	5
22	N42098	Locknut - 5/16 (2018 to present)	1
	N31016	Wing Nut - 5/16 (Prior to 2018).....	1
23	S51330	Hose Holder Clamp.....	1
24	S51463	Hose Holder	1
25	S51464	Hex Bolt - 1/2 x 2 Lg Gr. 8.....	1
26	S51466	Carriage Bolt - 5/16 x 2 Lg	1
27	W-522	Lockwasher - 5/16.....	1
	S46595	Optional Secondary Hose Holder Kit - (Includes Items 22 - 27)	

Opener Assembly 2020 to 2021

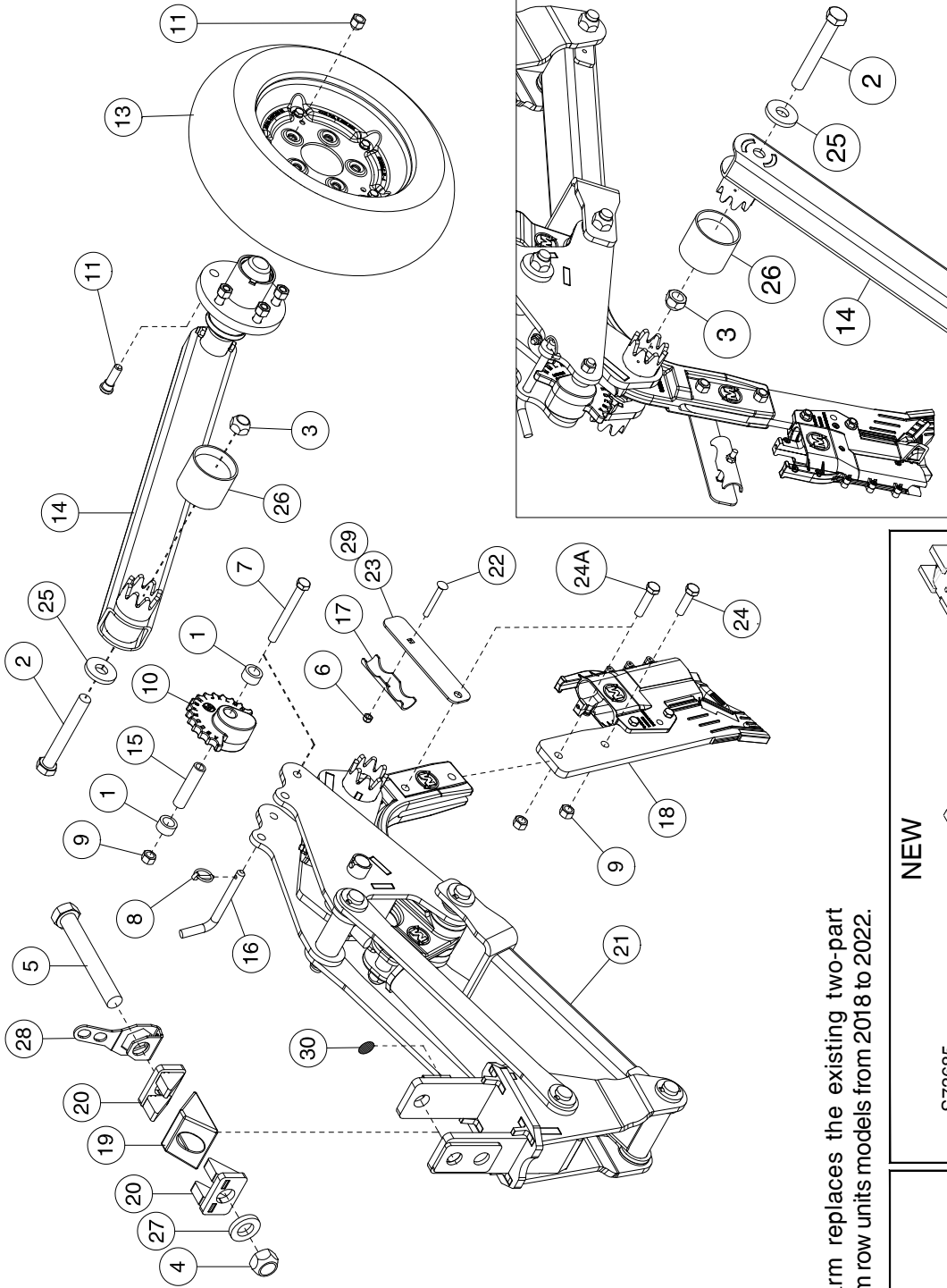

The new welded packer arm replaces the existing two-part assembly on welded Quantum row units models from 2018 to 2022.

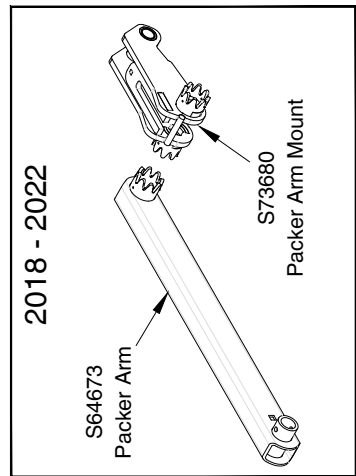
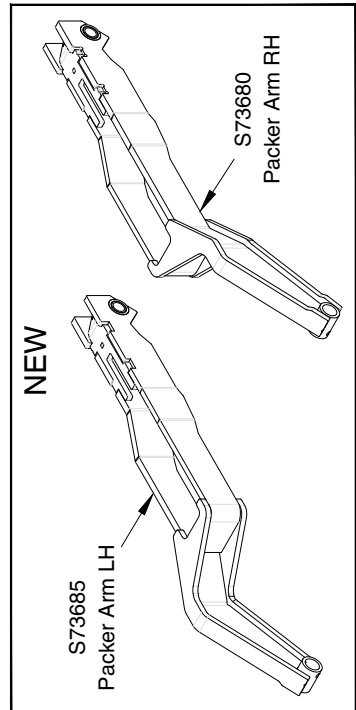

Opener Assembly - 2020 to 2021

Item	Part No.	Description	Qty																																																																																										
1	S65000	Cam Brace Bushing - 0.765 ID x 1-1/8 OD x 0.58 Lg.....	2																																																																																										
2	D-5558	Hex Bolt - 3/4 x 6 Lg.....	1																																																																																										
3	D-5273	Lock Nut - 3/4 Unitorque	7																																																																																										
4	D-5274	Lock Nut - 1 Unitorque	1																																																																																										
5	S42952	Hex Bolt - 1 x 6 5/8 Lg.....	1																																																																																										
6	D-5272	Lock Nut - 5/16 Unitorque	1																																																																																										
7	S66403	Hex Bolt - 1/2 x 4 1/2 Lg - GR.8.....	1																																																																																										
8	S42294	Lynch Pin - 3/16 Dia x 1-3/8 Lg	1																																																																																										
9	S47110	Hex Nut - 1/2 Center Lock.....	3																																																																																										
10	S49260	Depth Cam - Cast	1																																																																																										
11	S50246	Tapered Wheel Nut - 1/2-20UNF	5																																																																																										
12	S50247	Press-In Wheel Stud - 1/2 - 20UNF.....	5																																																																																										
13	S64194	Otico Tire - 4 1/2.....	1																																																																																										
	S64195	Otico Tire - 5 1/2.....																																																																																											
14	S64673	Packer Arm.....	1																																																																																										
15	S64698	Bushing - 0.510 ID x 0.750 OD x 3.094 Lg	1																																																																																										
16	S65061	Depth Pin - 1/2 Dia.....	1																																																																																										
17	S65070	Hose Holder	1																																																																																										
18	S65121	Right Sideband Boot Kit - SHIELD CORE	1																																																																																										
	S65122	Left Sideband Boot Kit - SHIELD CORE																																																																																											
	S65123	Paired Row Boot Kit - SHIELD CORE																																																																																											
	*****	Single Shoot Boot Kit - SHIELD CORE																																																																																											
19	S66337	Cast Center Wedge - 3 wide	1																																																																																										
20	S69115	Steel Outer Wedge - 2 3/4 wide (Replaced by S66338 - Cast Alloy).....	2																																																																																										
21	S71912	Row Unit - Right (Includes items 1,2,3,7,8,9,10,11,12,14,15,16, 25 and 26) Shown.....	1																																																																																										
	S71913	Row Unit - Left (Includes items 1,2,3,7,8,9,10,11,12,14,15,16, 25 and 26)																																																																																											
		Note: The only difference between the Left and Right Row Unit is the orientation of the packer arm assembly.																																																																																											
22	S51466	Carriage Bolt - 5/16 x 2 Lg	1																																																																																										
23	S65851	Hose Holder Bracket - Cast Shankholder	1																																																																																										
24	W-487	Hex Bolt - 1/2 x 1 3/4 Lg.....	2																																																																																										
24A	S51464	Hex Bolt - 1/2 x 2 Lg - GR 8 (Hose Holder Replacement Bolt)	1																																																																																										
25	S65821	Washer - 2 1/4 OD x 25/32 ID	1																																																																																										
26	S69349	Sleeve Bushing.....	1																																																																																										
27	F-4490	Flatwasher - 1 1/32 ID x 1 7/8 OD x 1/4 Thick	1																																																																																										
28	S72070	Hose Holder - Opener - Low Profile	1																																																																																										
29	S65852	Hose Holder Kit - Cast Shankholder - Contains Items 6, 9, 17, 22, 23 & 24A	1																																																																																										
30	S66171	Openers Number Decal - 1 per machine <div style="border: 1px solid black; padding: 2px; margin-top: 5px;"> <table style="width: 100%; text-align: center; border-collapse: collapse;"> <tr><td>1</td><td>4</td><td>7</td><td>10</td><td>13</td><td>16</td><td>19</td><td>22</td><td>25</td><td>28</td><td>31</td><td>34</td><td>37</td><td>40</td><td>43</td><td>46</td><td>49</td><td>52</td><td>55</td><td>58</td><td>61</td><td>64</td><td>67</td><td>70</td><td>73</td><td>76</td><td>79</td><td>82</td><td>85</td><td>88</td></tr> <tr><td>2</td><td>5</td><td>8</td><td>11</td><td>14</td><td>17</td><td>20</td><td>23</td><td>26</td><td>29</td><td>32</td><td>35</td><td>38</td><td>41</td><td>44</td><td>47</td><td>50</td><td>53</td><td>56</td><td>59</td><td>62</td><td>65</td><td>68</td><td>71</td><td>74</td><td>77</td><td>80</td><td>83</td><td>86</td><td>89</td></tr> <tr><td>3</td><td>6</td><td>9</td><td>12</td><td>15</td><td>18</td><td>21</td><td>24</td><td>27</td><td>30</td><td>33</td><td>36</td><td>39</td><td>42</td><td>45</td><td>48</td><td>51</td><td>54</td><td>57</td><td>60</td><td>63</td><td>66</td><td>69</td><td>72</td><td>75</td><td>78</td><td>81</td><td>84</td><td>87</td><td>90</td></tr> </table> </div>	1	4	7	10	13	16	19	22	25	28	31	34	37	40	43	46	49	52	55	58	61	64	67	70	73	76	79	82	85	88	2	5	8	11	14	17	20	23	26	29	32	35	38	41	44	47	50	53	56	59	62	65	68	71	74	77	80	83	86	89	3	6	9	12	15	18	21	24	27	30	33	36	39	42	45	48	51	54	57	60	63	66	69	72	75	78	81	84	87	90	
1	4	7	10	13	16	19	22	25	28	31	34	37	40	43	46	49	52	55	58	61	64	67	70	73	76	79	82	85	88																																																																
2	5	8	11	14	17	20	23	26	29	32	35	38	41	44	47	50	53	56	59	62	65	68	71	74	77	80	83	86	89																																																																
3	6	9	12	15	18	21	24	27	30	33	36	39	42	45	48	51	54	57	60	63	66	69	72	75	78	81	84	87	90																																																																

Opener Assembly Cast - 2022 to Present

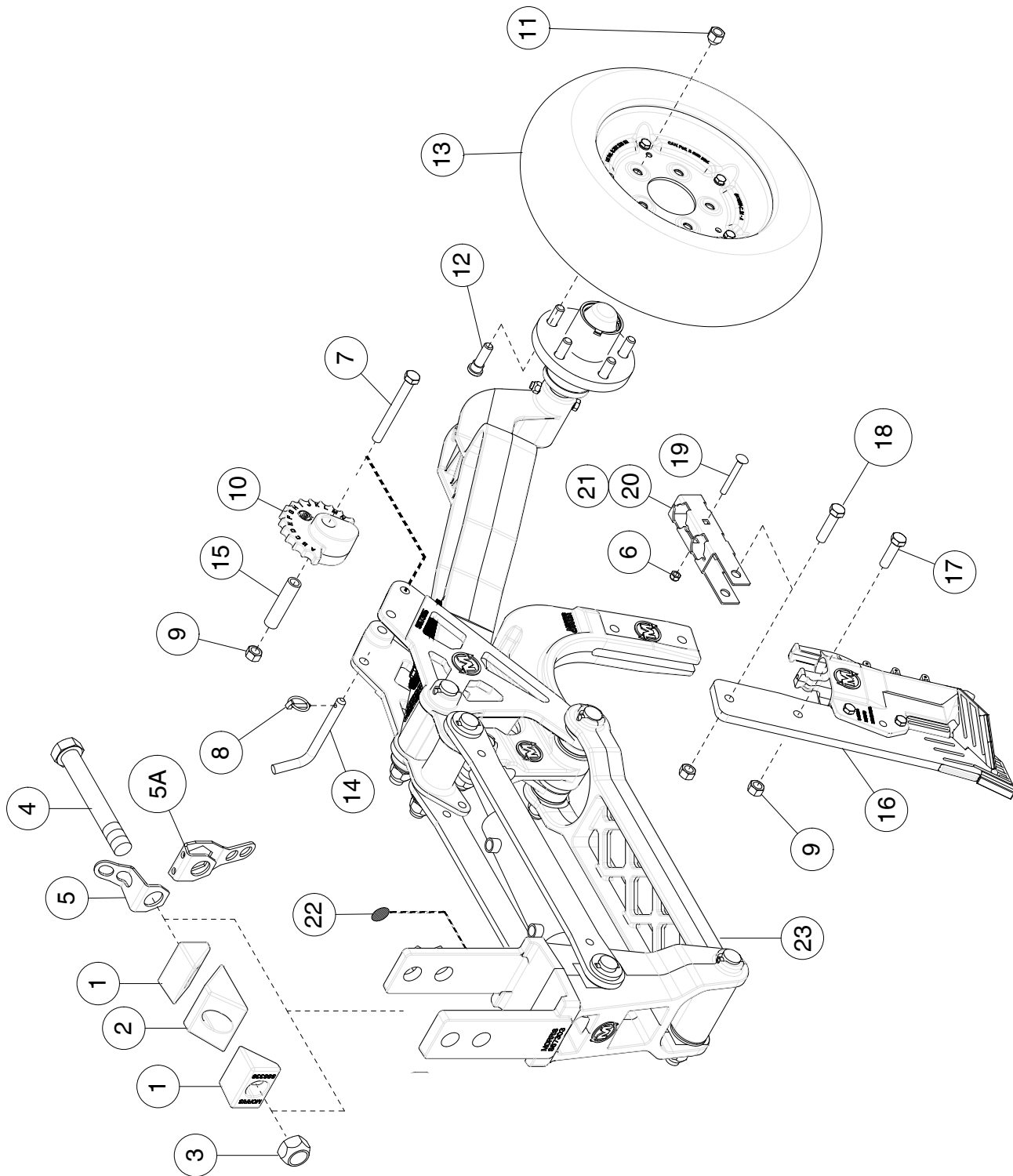

Opener Assembly - Cast - 2022 to Present

Item	Part No.	Description	Qty
1	S66338	Outer Wedge - Cast Alloy	2
2	S66337	Centre Wedge - Cast.....	1
3	D-5274	Lock Nut - 1 Unitorque	1
4	S42952	Hex Bolt - 1 x 6 5/8 Lg.....	1
5	S66245	Hose Holder - Opener.....	1
5A	S67170	Hose Holder - Opener - Low Profile - 4 per machine	
6	D-5272	Lock Nut - 5/16 Unitorque	1
7	S66403	Hex Bolt - 1/2 x 4 1/2 Lg - GR.8.....	1
8	S42294	Lynch Pin - 3/16 Dia x 1-3/8 Lg	1
9	S47110	Hex Nut - 1/2 Center Lock.....	3
10	S49260	Depth Cam - Cast	1
11	S50246	Tapered Wheel Nut - 1/2-20UNF.....	5
12	S50247	Press-In Wheel Stud - 1/2 - 20UNF.....	5
13	*****	See "Packer Wheel Assemblies".....	1
14	S65061	Depth Pin - 1/2 Dia.....	1
15	S67944	Bushing - 0.510 ID x 0.750 OD x 1 31/32 Lg	1
16	S72321	Kit: Forged Paired Row IP - LD	1
	S72322	Kit: Forged Paired Row IP - HP	
	S72324	Forged Sideband Boot Kit - Left IP - LD	
	S72323	Forged Sideband Boot Kit - Right IP - LD	
	S72325	Forged Single Shoot Assembly	
17	W-487	Hex Bolt - 1/2 x 1 3/4 Lg.....	1
18	S51464	Hex Bolt - 1/2 x 2 Lg - GR 8 (Hose Holder Replacement Bolt)	1
19	S51466	Carriage Bolt - 5/16 x 2 Lg	1
20	S69305	Hose Holder	1
21	S72297	Hose Holder Kit - Contains Items 6, 9, 18, 19 & 20.....	1
22	S66171	Openers Number Decal - 1 per machine	
		<div style="display: flex; flex-wrap: wrap; justify-content: space-around; text-align: center;"> 147101316192225283134374043464952555861646770737679828588</div> <div style="display: flex; flex-wrap: wrap; justify-content: space-around; text-align: center;"> 258111417202326293235384144475053565962656871747780838689</div> <div style="display: flex; flex-wrap: wrap; justify-content: space-around; text-align: center;"> 369121518212427303336394245485154576063666972757881848790</div>	
23	S72302	Row Unit - Right (Includes items 7, 8, 9,10,11,12,14,15) - Shown	1
	S72303	Row Unit - Left (Includes items 7, 8, 9,10,11,12,14,15)	
		<p>Abbreviations:</p> <p>IP - Injected Polymer</p> <p>LD - Low Disturbance</p> <p>HP - High Penetration</p>	

Body Assembly Prior to 2016

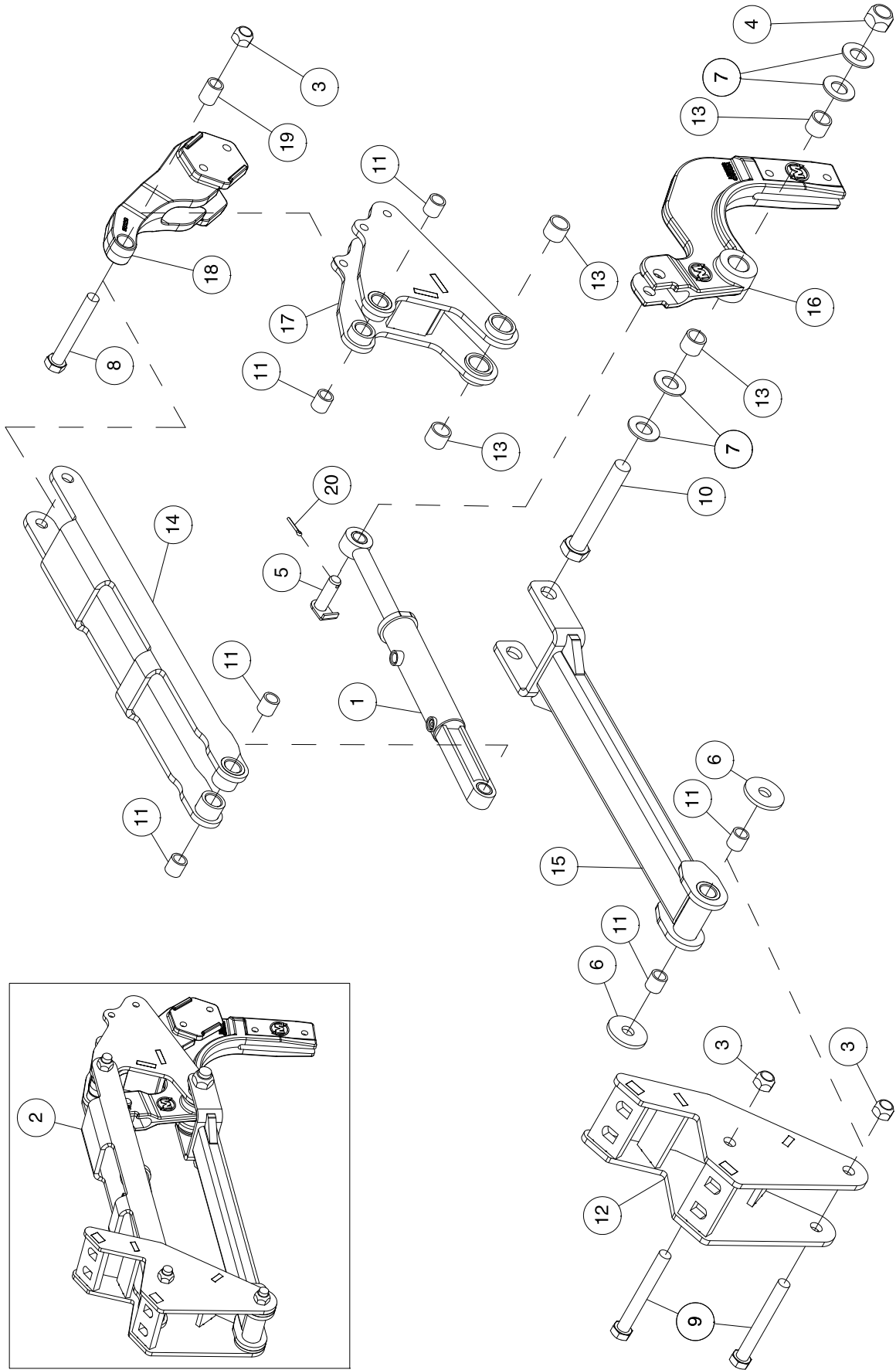

Opener - Body Assembly - Prior to 2016

Item	Part No.	Description	Qty
1	C51033	Hydraulic Cylinder - 1 3/4 Bore x 4 Stroke	1
2	*****	Base Assembly (Includes all items in list)	1
3	D-5273	Locknut - 3/4 Unitorque.....	3
4	D-5274	Locknut - 1 Unitorque.....	1
5	S42673	Lipped Pin.....	1
6	S42674	Washer - 2 1/2 OD x 25/32 ID x 1/4	2
7	S42675	Washer - 1 1/32 ID x 2 OD x 1/8	4
8	S51004	Hex Bolt - 3/4 x 5 1/8 Lg GR-8	1
9	S51006	Hex Bolt - 3/4 x 6 1/8 Lg GR-8	2
10	S42952	Hex Bolt - 1 x 6 5/8 Lg.....	1
11	S51494	Bushing - 0.756/0.759 ID x 1.003/1.005 OD x 1.000 Lg.....	6
12	S51005	Mounting Bracket	1
13	S47527	Polygon Fiber Bushing - 1ID x 1 1/4 OD x 1 Lg	4
14	S48852	Top Link	1
15	S48853	Lower Link.....	1
16	S49250	Cast Shankholder	1
17	S49290	Opener Body.....	1
18	S50210	Packer Arm Pivot Bracket - Cast.....	1
19	S53277	Packer Pivot Bushing - 0.756/0.759 ID x 1.003/1.005 OD x 1 5/16 Lg.....	1
20	W-530	Cotter Pin - 5/32 x 1 Lg	1
	S62065	Overhaul Kit (See Page 3-7 for details)	

Body Assembly 2016 to 2019

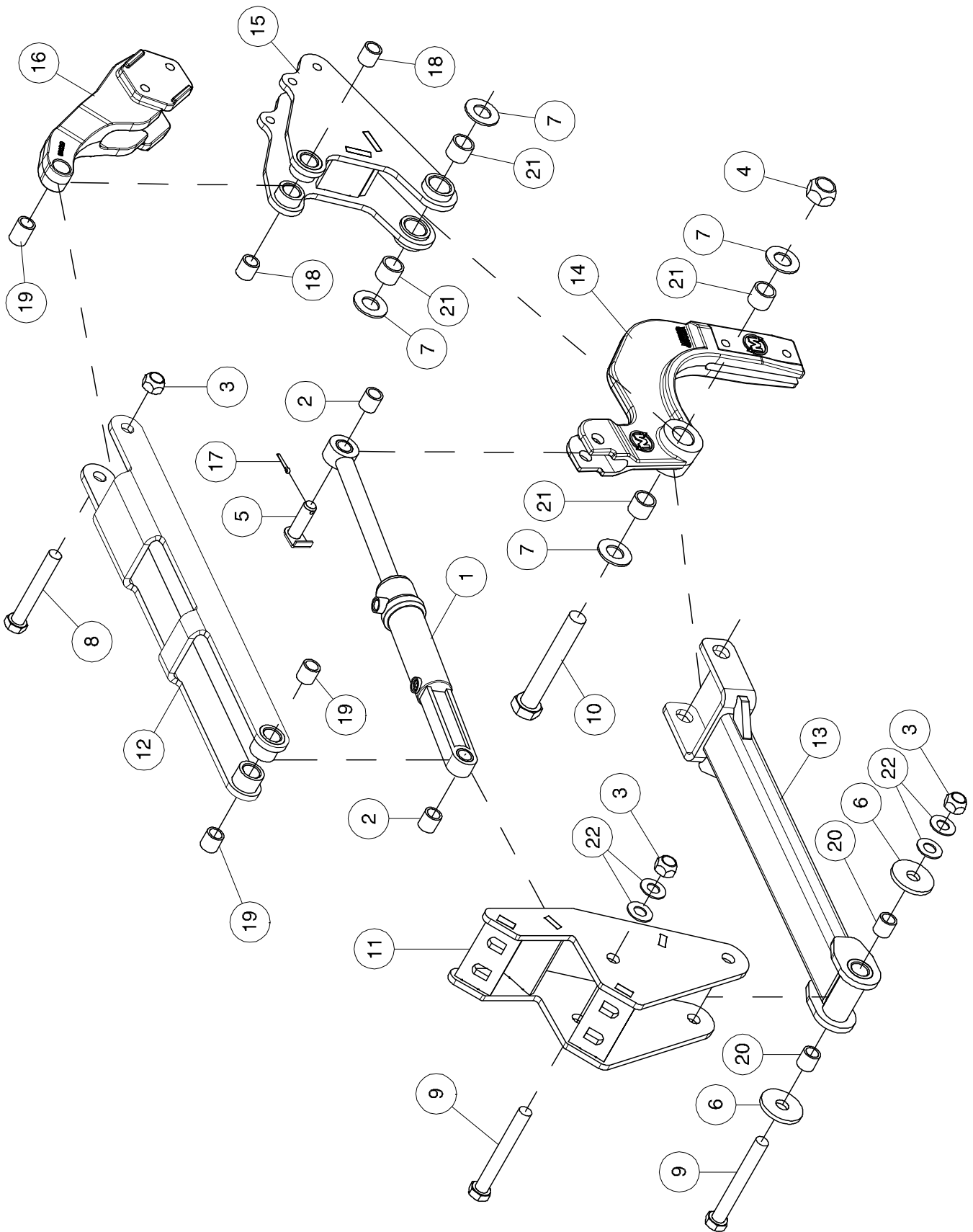

Opener - Body Assembly - 2016 to 2019

Item	Part No.	Description	Qty
1	C51033	Hydraulic Cylinder - 1 3/4 Bore x 4 Stroke	1
2	S51494	Bushing - 0.756/0.759 ID x 1.003/1.005 OD x 1.000 Lg	2
3	D-5273	Locknut - 3/4 Unitorque	3
4	D-5274	Locknut - 1 Unitorque	1
5	S58730	Pin Chrome - 3/4 x 1 29/32 UL	1
6	S42674	Washer - 25/32 ID x 2 1/2 OD x 1/4	2
7	S42675	Washer - 1 1/32 ID x 2 OD x 1/8	4
8	S51004	Hex Bolt - 3/4 x 5 1/8 Lg GR-8	1
9	S51006	Hex Bolt - 3/4 x 6 3/8 Lg GR-8	2
10	S42952	Hex Bolt - 1 x 6 5/8 Lg	1
11	S58748	Mounting Bracket	1
12	S59801	Top Link (Includes item 19)	1
13	S59802	Lower Link (Includes item 20)	1
14	S59804	Shankholder - Cast (Includes item 21)	1
15	S59803	Opener Body (Includes item 18 & 21)	1
16	S59807	Packer Arm Pivot Bracket - Cast (Includes item 19)	1
17	W-530	Cotter Pin - 5/32 x 1 Lg	1
18	S58744	Q2 Bushing - 3/4 ID x 1 OD x 1 Lg Nominal size	2
19	S58746	Q2 Bushing - 3/4 ID x 1 OD x 1.313 Lg Nominal size	3
20	S58747	Q2 Bushing - 3/4 ID x 1 OD x 1.875 Lg Nominal size	2
21	S59806	Q2 Bushing - 1 ID x 1 1/4 OD x 1 Lg Nominal size	4
22	W-476	Flatwasher - 13/16 ID x 1 1/2 OD x 11 Ga	4
	S59800	Base Assembly (Includes all items above)	1
	S62065	Overhaul Kit (Includes items 2, 3, 4, 5, 6, 7, 8, 9, 10, 17, 18, 19, 20, 21 and 22)	

Body Assembly
2020 to 2021

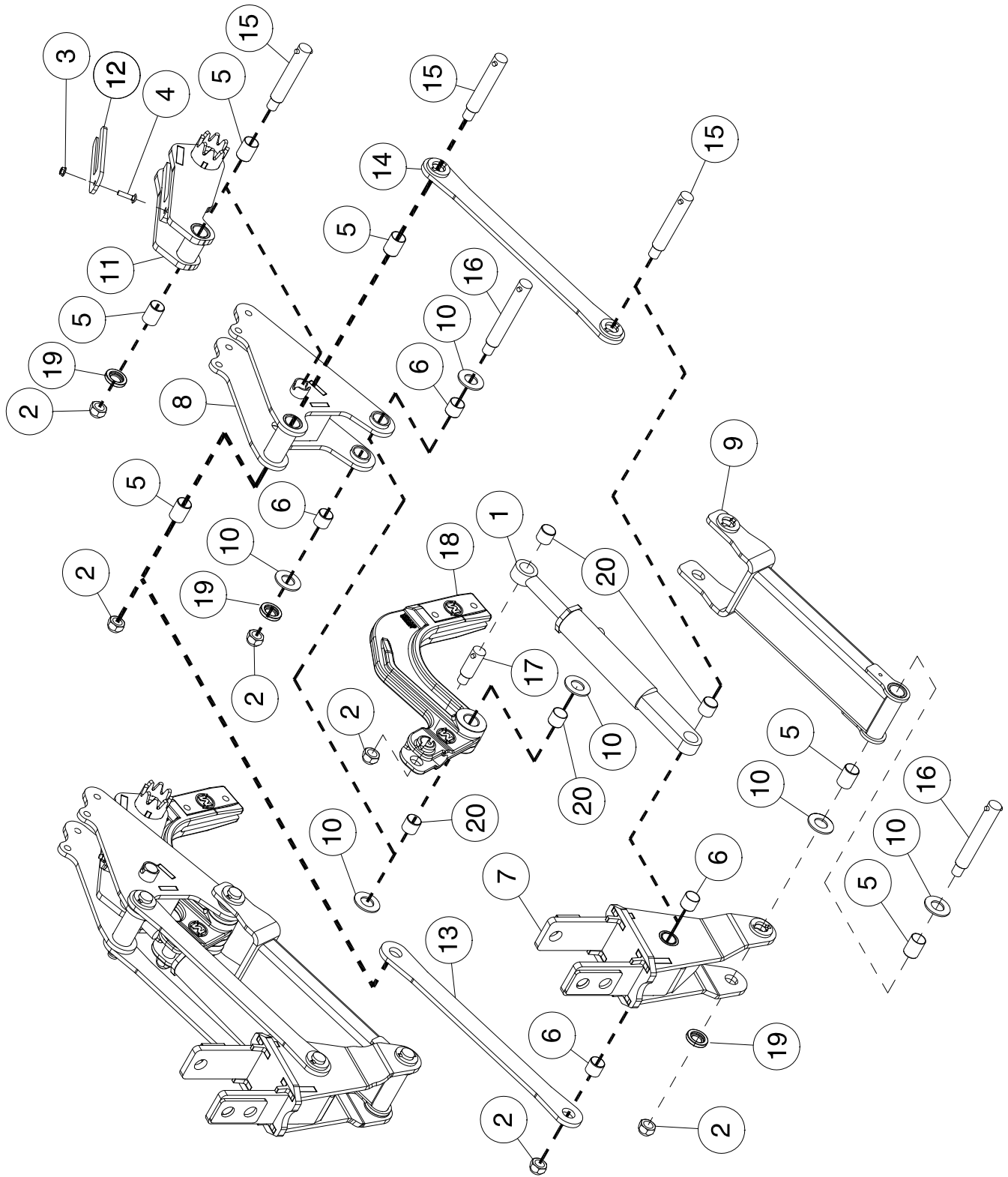

Body Assembly - 2020 to 2021

Item	Part No.	Description	Qty
1	C64546	Cylinder - 1 3/4 Bore x 4 Stroke (Includes Item 20)	1
2	D-5275	Locknut - 3/4 nylon insert.....	6
3	D-5278	Lock Nut - 5/16 Flanged.....	1
4	N31012	Carriage Bolt - 5/16 x 1 1/4 Lg	1
5	S62986	Q2 Bushing - 1 ID x 1 1/8 OD x 1 1/2 Lg Nominal size	6
6	S72042	EWS Bushing - 1 ID x 1 1/8 OD x 1 Lg Nominal size	4
7	S71902	C2 Mounting Bracket - (Includes Item 6 Qty of 2)	1
8	S64119	Opener Body - (Includes Item 5 Qty of 2 and Item 6 Qty 2).....	1
9	S64172	Bottom Link - (Includes Item 5 Qty of 2).....	1
10	S69398	Washer - 1 1/32 ID x 2 OD x 1/8	6
11	S64672	Packer Arm Mount - (Includes Item 5 Qty of 2)	1
12	S66251	Shim - Depth Adjustment - 1/4 Thick.....	1
13	S64759	Strap - Top Link.....	1
14	S65009	Top Link.....	1
15	S65037	Pin - Chrome - 1 Dia x 4 21/32 UL (Includes S73071 Roll Pin)	3
16	S65038	Pin - Chrome - 1 Dia x 5 9/16 UL (Includes S73071 Roll Pin).....	2
17	S65039	Pin - Chrome - 1 Dia x 1 29/32 UL (Includes S73071 Roll Pin)	1
18	S65048	Cast Shankholder - (Includes Item 20 Qty of 2).....	1
19	S72061	Washer - Machined Step - 0.765 ID x 1.063 ID x 1 9/16 OD x 0.266 Thick	3
20	S72042	EWS Bushing - 1 ID x 1 1/8 OD x 1 Lg Nominal size	4

S73260

Quantum Steel Row Unit Rebuild Kit (Includes Items 2, 5, 6, 10, 15, 16, 17, 19, 20)

The new welded packer arm replaces the existing two-part assembly on welded Quantum row units models from 2018 to 2022. This redesigned packer arm is a more robust solution.

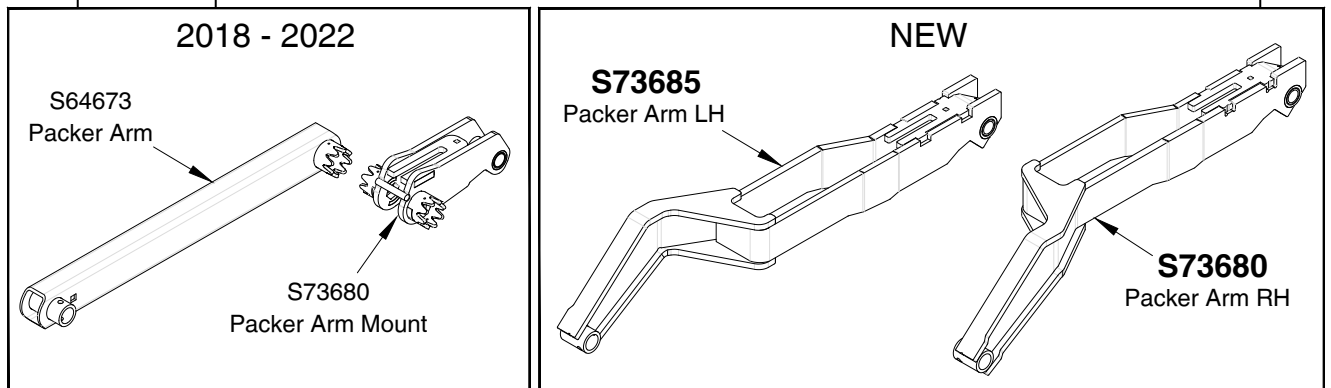

Body Assembly Cast - 2022 to Present

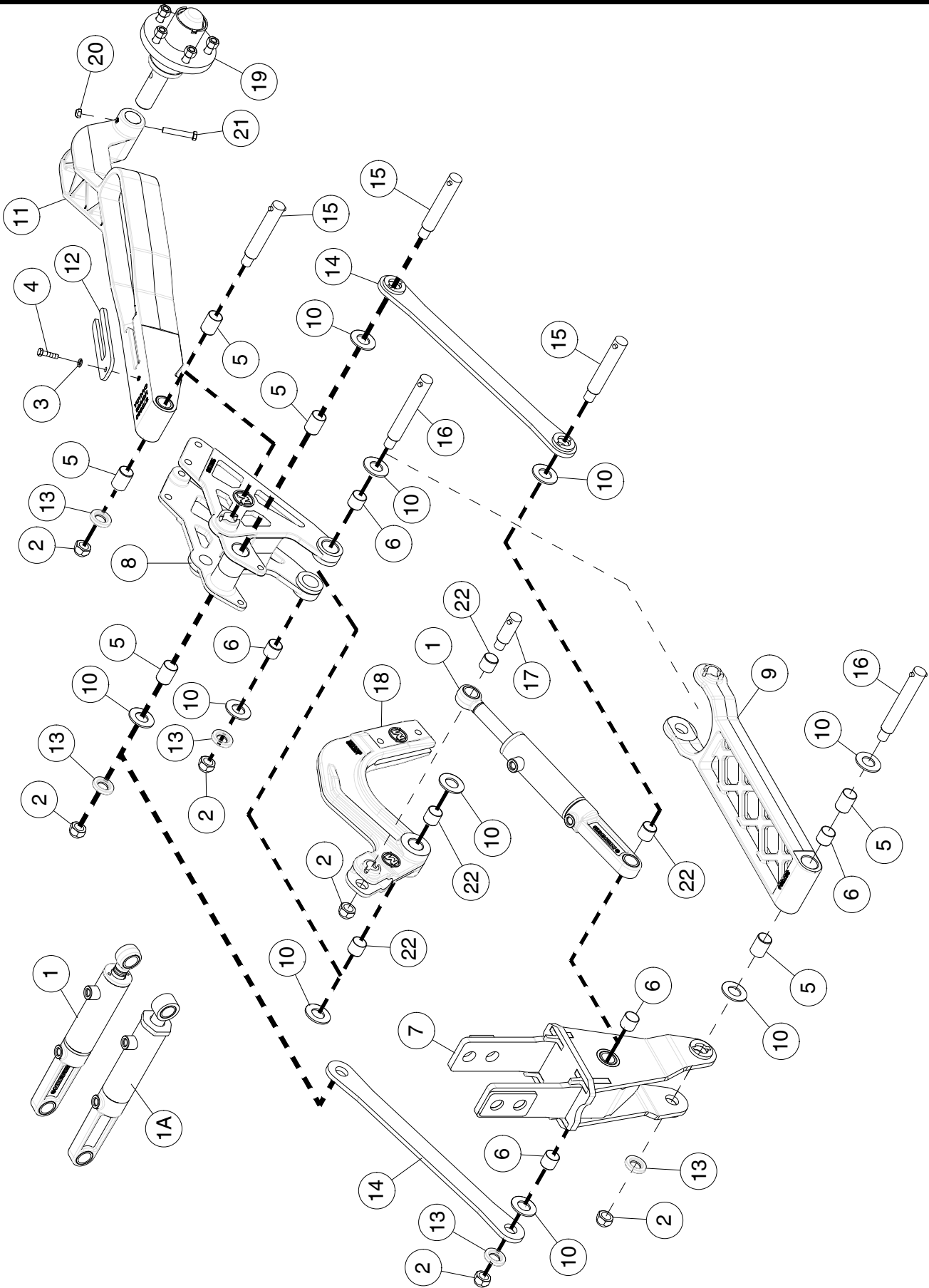

Body Assembly - Cast - 2022 to Present

Item	Part No.	Description	Qty
1	C72090	Cylinder - 1 3/4 Bore x 4 Stroke - (Includes Item 22 Qty of 2) - 2023 (Seal Kit C72720) ..	1
1A	C68272	Cylinder - 1 3/4 Bore x 4 Stroke - (Includes Item 22 Qty of 2) (Seal Kit C71900)	
2	D-5275	Locknut - 3/4 nylon insert.....	6
3	W-522	Lock Washer - 5/16	1
4	F-1767	Hex Bolt - 5/16 x 3/4 Lg.....	1
5	S67549	Q2 Bushing - 1 ID x 1 1/4 OD x 1 1/2 Lg Nominal size.....	6
6	S59806	Q2 Bushing - 1 ID x 1 1/4 OD x 1 Lg Nominal size.....	5
7	S67303	Mounting Bracket - Cast - (Includes Item 22 Qty of 2) - 2023.....	1
	S69360	Mounting Bracket - Welded - (Includes Item 6 Qty of 2).....	1
8	S67305	Opener Body - (Includes Item 5 Qty of 2 and Item 6 Qty 2).....	1
9	S67304	Bottom Link - (Includes Item 5 Qty of 2 and Item 6 Qty 1)	1
10	S69398	Washer - 1 1/32 ID x 2 OD x 1/8.....	10
11	S72060	Packer Arm - Right - (Includes Item 5 Qty of 2) - Shown	1
	S72065	Packer Arm - Left - (Includes Item 5 Qty of 2)	1
12	S66251	Shim - Depth Adjustment - 1/4 Thick.....	1
13	S72061	Washer - Step - Machined - 0.800 ID x 1.063 ID x 1 9/16 OD x 0.266 Thick.....	5
14	S65009	Top Link.....	2
15	S69573	Pin - Chrome - 1 Dia x 5 1/16 UL (Includes S73071 Roll Pin).....	3
16	S69574	Pin - Chrome - 1 Dia x 5 23/32 UL (Includes S73071 Roll Pin)	2
17	S69598	Pin - Chrome - 1 Dia x 1 29/32 UL (Includes S73071 Roll Pin)	1
18	S67613	Cast Shankholder - (Includes Item 22 Qty of 2)	1
19	S48850	Spindle Hub Assembly	1
20	M-3388	Locknut - 3/8 Unitorque.....	1
21	W-480	Hex Bolt - 3/8 x 2 1/2 Lg.....	1
22	S72046	EWS Bushing - 1 ID x 1 1/4 OD x 1 Lg Nominal size.....	4
	S73284	Quantum Cast Row Unit Rebuild Kit (Includes Items 2, 5, 6, 10, 13, 15, 16, 17, 22)	

Packer Arm Assembly Prior to 2020

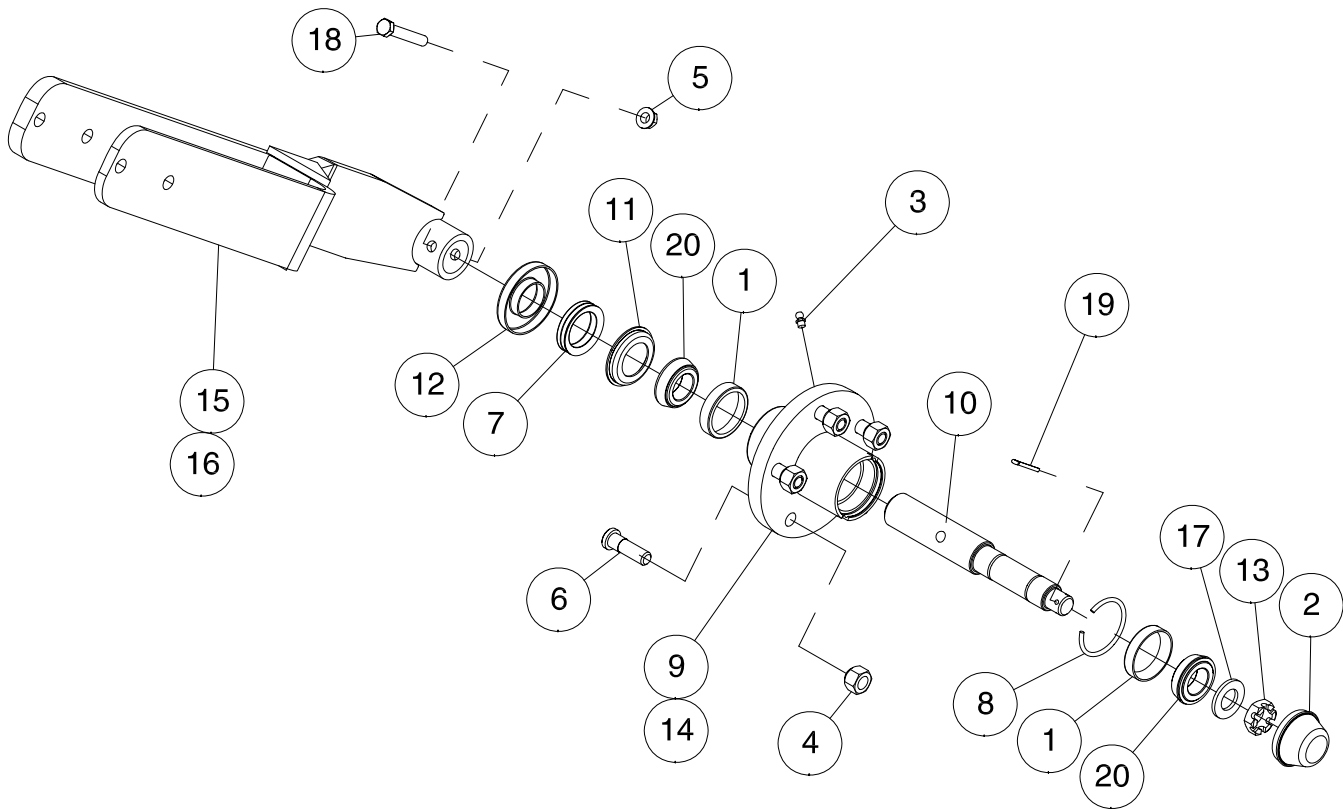

Item	Part No.	Description	Qty
1	N14009	Bearing Cup	2
2	N14011	Dust Cap	1
3	S-752	Grease Zerk - 1/4	1
4	S50246	Tapered Wheel Nut - 1/2-20 UNF	5
5	S27987	Lock Nut - 3/8 Center Lock Flange	1
6	S50247	Wheel Stud - Press In - 1/2-20 UNF	5
7	S48842	V-Seal - 1 1/4 Shaft	1
8	S48843	Dust Cap Retaining Wire	1
9	S50761	Hub Casting - 1000 Lb - 5 Bolt (Includes Items 1 and 6)	1
10	S48846	Spindle - 1 1/4 Dia	1
11	S48847	Seal Counterface	1
12	S48848	Seal Retainer	1
13	S48849	Slotted Jam Nut - 3/4	1
14	S48850	Packer Hub Assembly (Includes Items 1, 2, 3, 4, 6, 7, 8, 9, 10, 11, 12, 13, 17, 19, 20)	1
15	S49299	Packer Arm	1
16	S49500	Packer Arm Sub-Assembly (Includes all Items Listed)	1
17	W-476	Flat Washer - 3/4	1
18	W-479	Hex Bolt - 3/8 x 2 1/4 Lg.	1
19	W-529	Cotter Pin - 1/8 x 1 Lg	1
20	W-4187	Bearing Cone	2

Packer Arm Assembly Adjustable - Prior to 2020

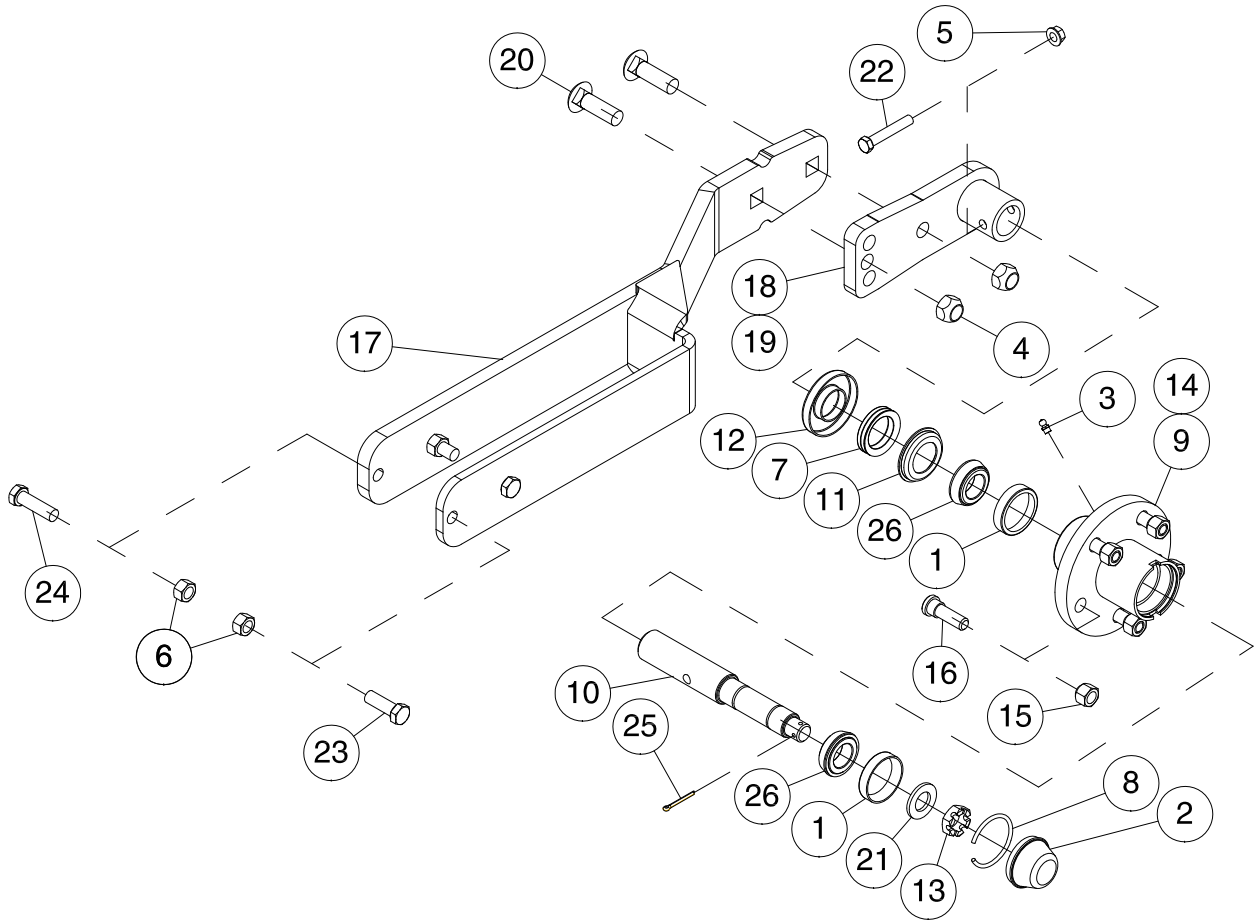

Item	Part No.	Description	Qty
1	N14009	Bearing Cup	2
2	N14011	Dust Cap	1
3	S-752	Grease Fitting - 1/4	1
4	S-1197	Locknut - 5/8 Unitorque.....	2
5	S27987	Flange Lock Nut - 3/8 W/Center Lock	1
6	S47110	Hex Nut - 1/2 Center Lock.....	4
7	S48842	V-Seal - 1 1/4 Shaft.....	1
8	S48843	Dust Cap Retaining Wire	1
9	S50761	Hub Casting - 1000 Lb - 5 Bolt (Includes Items 1 and 6)	1
10	S48846	Spindle - 1 1/4 Dia	1
11	S48847	Seal Counterface	1
12	S48848	Seal Retainer	1
13	S48849	Slotted Jam Nut - 3/4	1
14	S48850	Packer Hub Assembly	1
15	S50246	Tapered Wheel Nut - 1/2.....	5
16	S50247	Press-In Wheel Stud - 1/2	5
17	S51040	Packer Arm.....	1
18	S51041	Packer Spindle Receiver	1
19	S51160	Packer Arm Sub-Assembly.....	1
20	T-5268	Carriage Bolt - 5/8 x 2 Lg	2
21	W-476	Flat Washer - 3/4.....	1
22	W-479	Hex Bolt - 3/8 x 2 1/4 Lg.....	1
23	W-486	Hex Bolt - 1/2 x 1 1/2 Lg.....	2
24	W-487	Hex Bolt - 1/2 x 1 3/4 Lg.....	2
25	W-529	Cotter Pin - 1/8 x 1 Lg	1
26	W-4187	Bearing Cone	2

Packer Arm Assembly Welded - 2020 to 2021

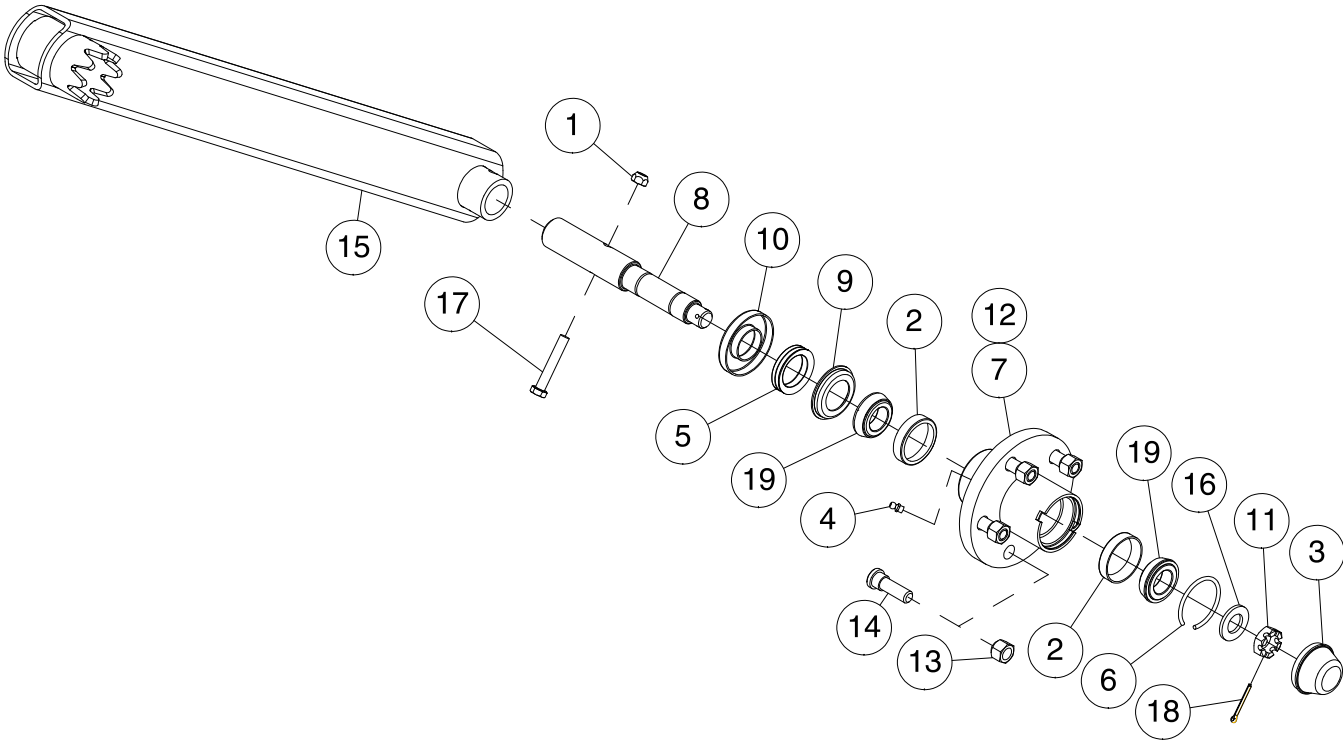

Item	Part No.	Description	Qty
1	M-3388	Lock Nut - 3/8 Unitorque	1
2	N14009	Bearing Cup	2
3	N14011	Dust Cap	1
4	S-752	Grease Zerk - 1/4	1
5	S48842	V-Seal - 1 1/4 Shaft	1
6	S48843	Dust Cap Retaining Wire	1
7	S48844	Hub Casting - 1000 Lb - 5 Bolt	1
8	S48846	Spindle - 1-1/4 Dia	1
9	S48847	Seal Counterface	1
10	S48848	Seal Retainer	1
11	S48849	Slotted Jam Nut - 3/4	1
12	S48850	Packer Hub Assembly (Includes Items# 2, 3, 4, 5, 6, 7, 8, 9, 10, 11, 13, 14, 16, 18 & 19) ..	1
13	S50246	Tapered Wheel Nut - 1/2.....	5
14	S50247	Press-In Wheel Stud - 1/2	5
15	S64673	Packer Arm.....	1
16	W-476	Washer - 3/4.....	1
17	W-479	Hex Bolt - 3/8 x 2 1/4 Lg.....	1
18	W-529	Cotter Pin - 1/8 x 1 Lg	1
19	W-4187	Bearing Cone	2

Packer Arm Assembly Cast - 2022 to Present

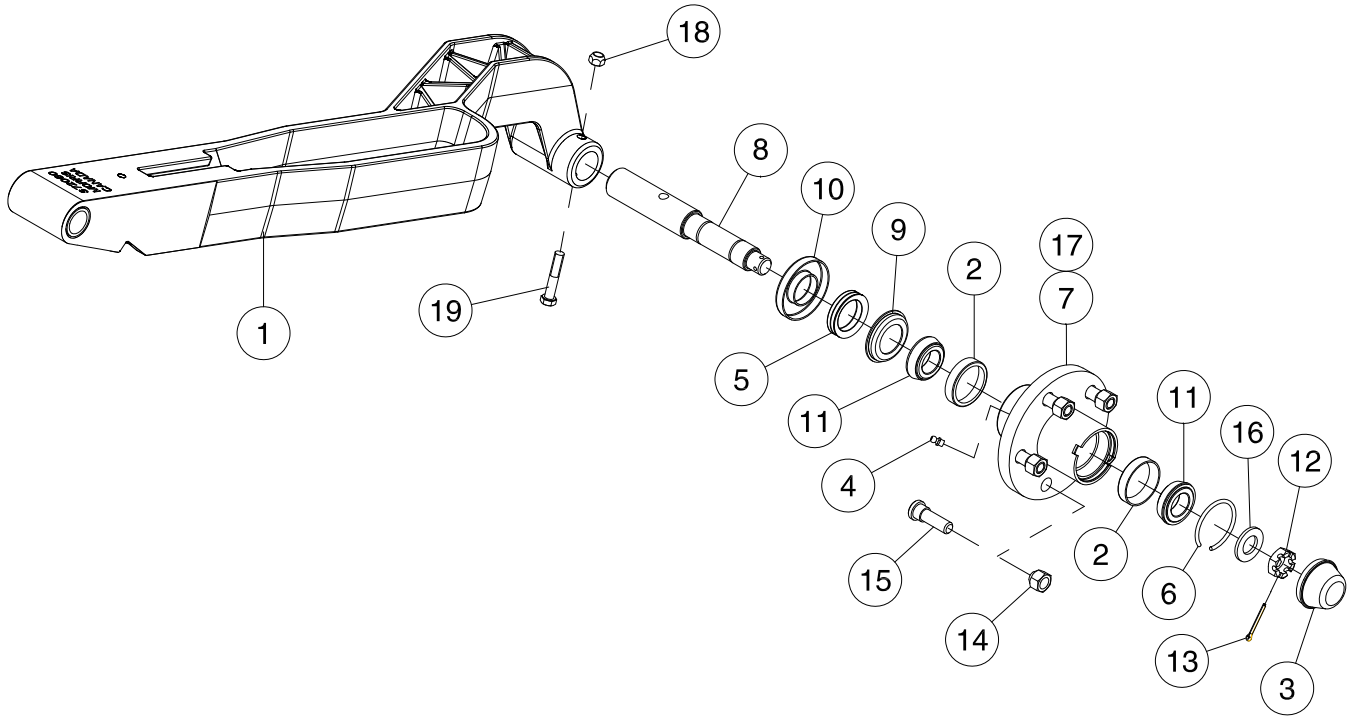

Item	Part No.	Description	Qty
1	S72060	Packer Arm - Right - Shown	1
	S72065	Packer Arm - Left	1
2	N14009	Bearing Cup	2
3	N14011	Dust Cap	1
4	S-752	Grease Zerk - 1/4	1
5	S48842	V-Seal - 1 1/4 Shaft	1
6	S48843	Dust Cap Retaining Wire	1
7	S48844	Hub Casting - 1000 Lb - 5 Bolt	1
8	S48846	Spindle - 1-1/4 Dia	1
9	S48847	Seal Counterface	1
10	S48848	Seal Retainer	1
11	W-4187	Bearing Cone	2
12	S48849	Slotted Jam Nut - 3/4	1
13	W-529	Cotter Pin - 1/8 x 1 Lg	1
14	S50246	Tapered Wheel Nut - 1/2.....	5
15	S50247	Press-In Wheel Stud - 1/2	5
16	W-476	Washer - 3/4.....	1
17	S48850	Packer Hub Assembly (Includes Items# 2, 3, 4, 5, 6, 7, 8, 9, 10, 11, 12, 13, 14, 15 & 16) ..	1
18	M-3388	Lock Nut - 3/8 Unitorque	1
19	W-480	Hex Bolt - 3/8 x 2 1/2 Lg.....	1

Opener Packer Wheel Assemblies

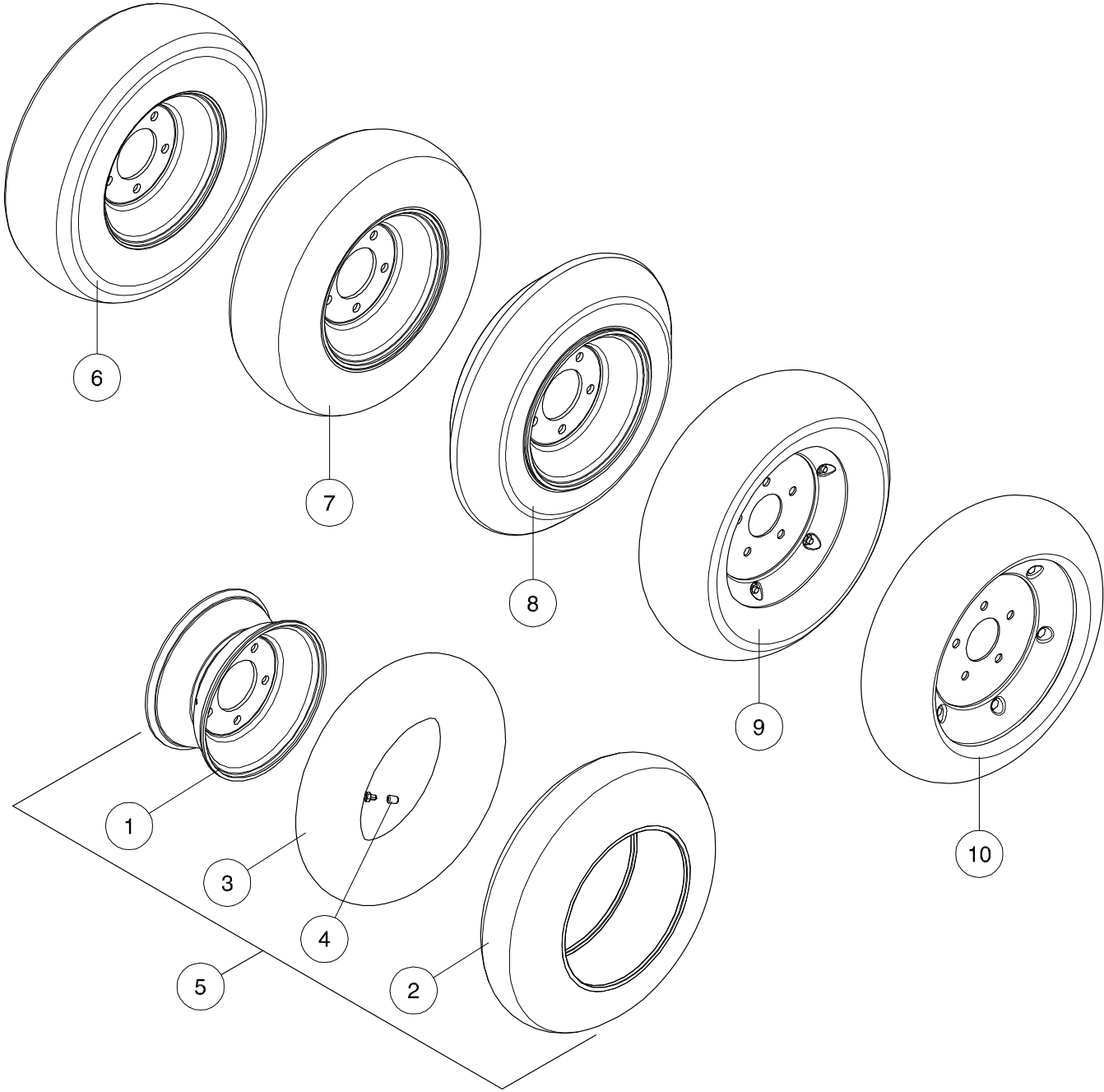

Item	Part No.	Description	Qty
1	S44301	Rim - 8 x 3.75 - 5 Bolt - Valve Stem - Pneumatic Tire.....	1
2	S44404	Pneumatic Tire - 480 x 8 Smooth.....	1
3	S44406	Tire Tube with Valve Cap.....	1
4	S44407	Valve Cap Metal	1
5	S44405	Pneumatic Tire - 480 (Includes items 1, 2, 3 & 4)	1
6	S44300	Semi Pneumatic Tire - 480 x 8	1
7	S44900	Semi Pneumatic Tire - 550 x 8	1
8	S47093	"V" Crown Packer Tire - 400 x 8.....	1
9	S64195	5.5" Otico Tire	1
10	S72075	4.5" AIC Tire - (Replaces S64194 - 4.5" Otico Tire)	1
	S73086	4.5" HD Tire	1

Seed Boot Injected Polymer Pair Row Kit

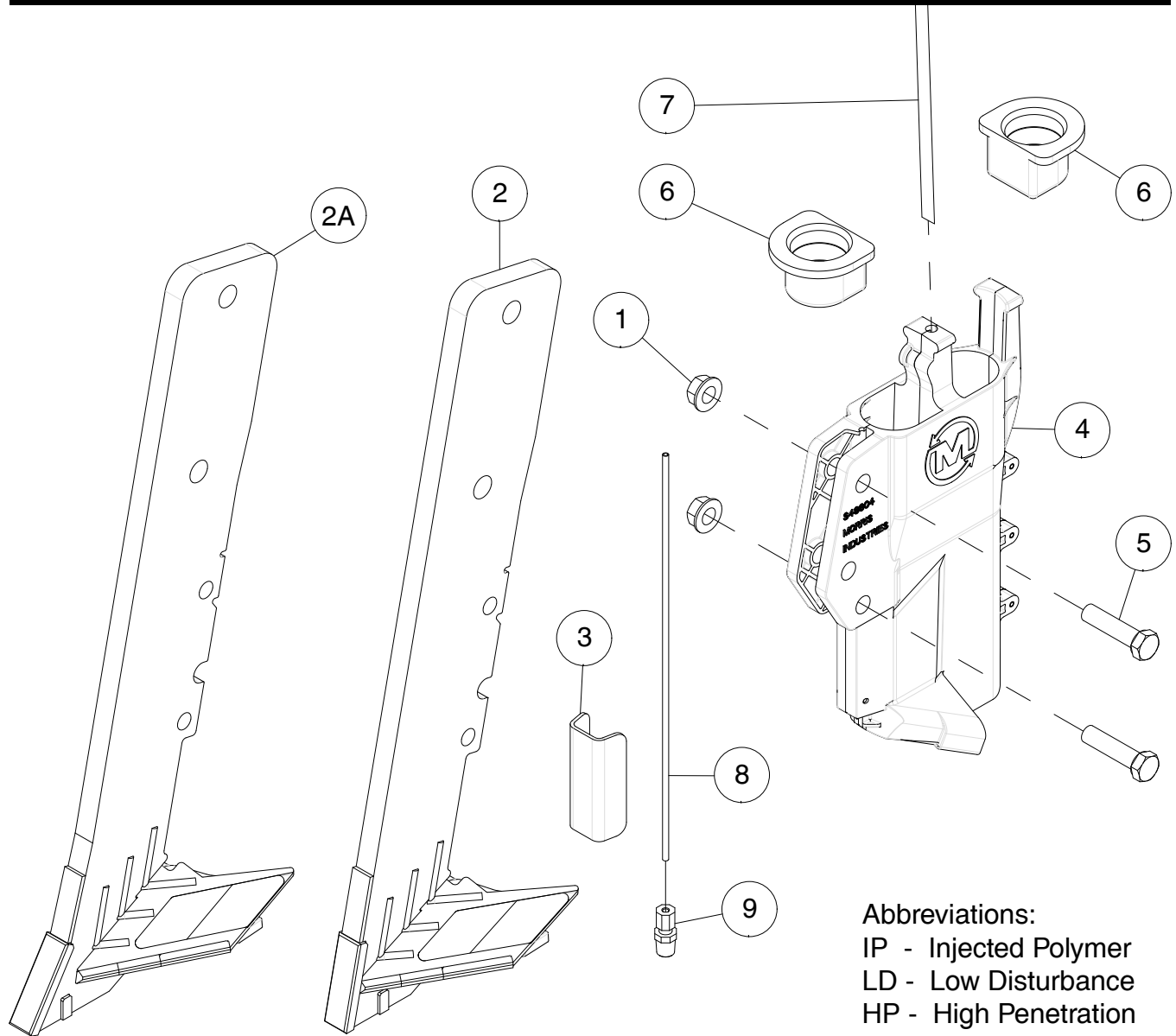

Abbreviations:
 IP - Injected Polymer
 LD - Low Disturbance
 HP - High Penetration

Item	Part No.	Description	Qty
1	S27987	Lock Nut - 3/8 Flange W/Center Lock.....	2
2	S72185	Forged Shank W/Carbide - Paired Row LD.....	1
2A	S72306	Forged Shank W/Carbide - Paired Row HP.....	1
3	S65074	Wear Guard - Claded.....	1
4	S56485	IP Paired Row Seed Boot.....	1
5	W-477	Hex Bolt - 3/8 x 1 1/2 Lg.....	2
6	S47076	Secondary Hose Grommet - 15/16 ID Hose - Prior to 2023.....	2
7	*****	Liquid Tube - 1/4 OD - See Liquid Kit Supplier for Tube.....	1
8	*****	Injector Tube - 1/8 OD - See NH3 Kit Supplier for Tube.....	1
9	S48814	Compression Fitting - 1/8 x 1/8.....	1
	S72321	Kit: Forged Paired Row IP - LD (Contains Items 1, 2, 3, 4 & 5)	
	S72322	Kit: Forged Paired Row IP - HP (Contains Items 1, 2A, 3, 4 & 5)	

Seed Boot Injected Polymer Left Sideband Kit

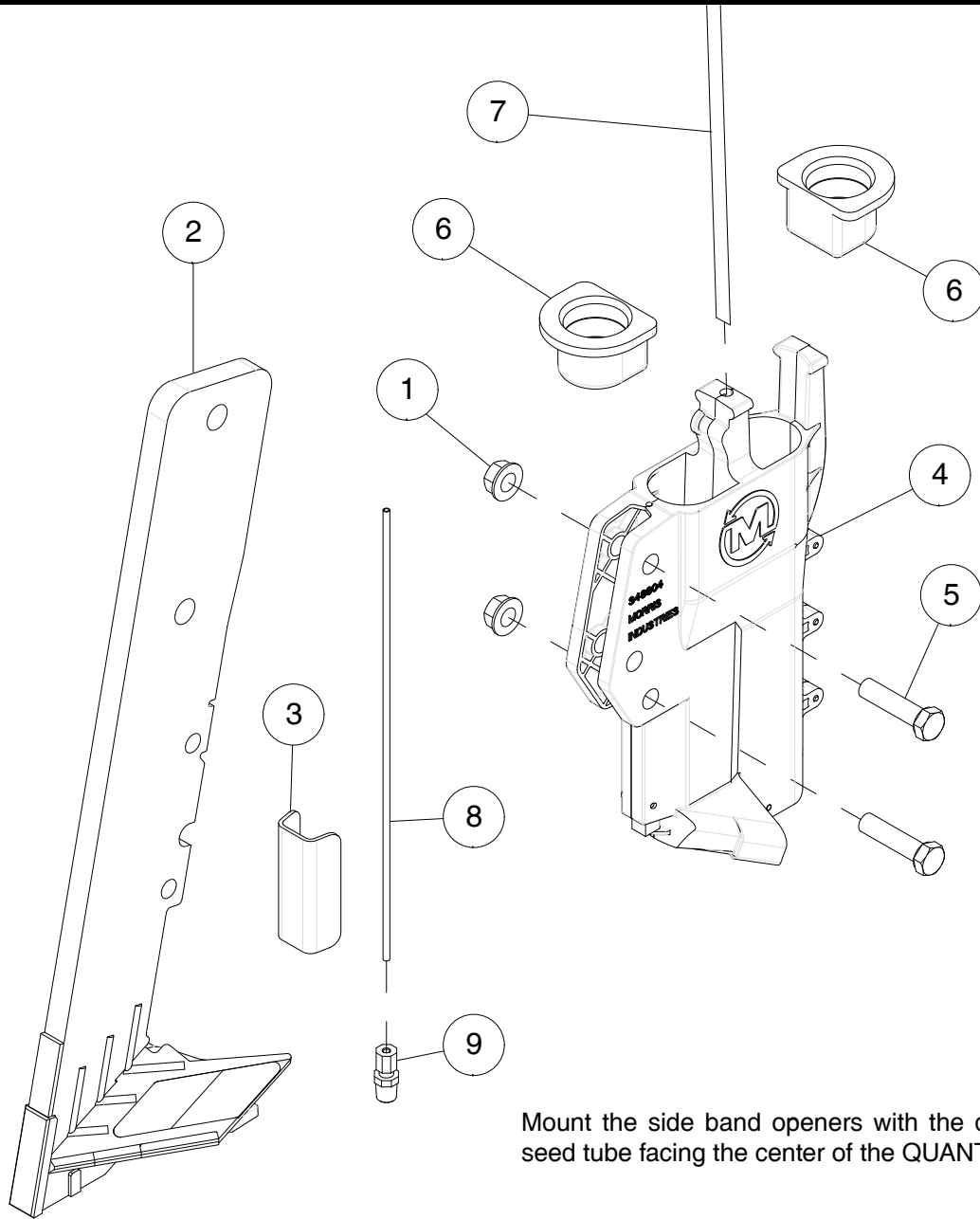

Mount the side band openers with the deflector and seed tube facing the center of the QUANTUM Air Drill.

Item	Part No.	Description	Qty
1	S27987	Lock Nut - 3/8 Flange W/Center Lock	2
2	S72309	Forged Shank W/Carbide - Sideband Left LD	1
3	S65074	Wear Guard - Claded	1
4	S56482	IP (Injected Polymer) Left Sideband Seed Boot	1
5	W-477	Hex Bolt - 3/8 x 1 1/2 Lg.....	2
6	S47076	Secondary Hose Grommet - 15/16 ID Hose - Prior to 2023	2
7	*****	Liquid Tube - 1/4 OD - See Liquid Kit Supplier for Tube	1
8	*****	Injector Tube - 1/8 OD - See NH3 Kit Supplier for Tube	1
9	S48814	Compression Fitting - 1/8 x 1/8	1
	S72324	Forged Sideband Boot Kit - Left IP - LD (Contains Items 1, 2, 3, 4 & 5)	1

Seed Boot Injected Polymer Right Side Band Kit

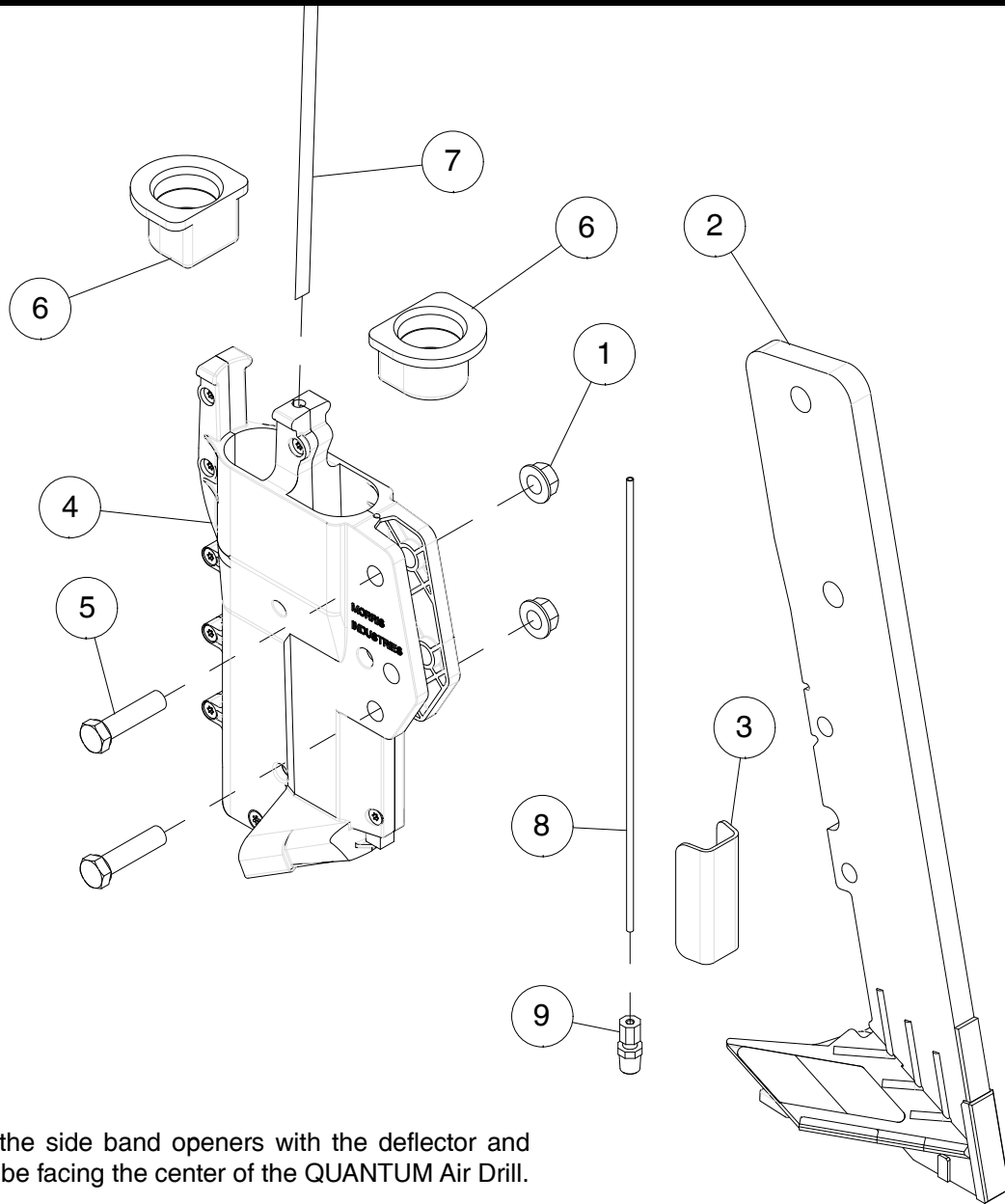

Mount the side band openers with the deflector and seed tube facing the center of the QUANTUM Air Drill.

Item	Part No.	Description	Qty
1	S27987	Lock Nut - 3/8 Flange W/Center Lock	2
2	S72308	Forged Shank W/Carbide - Sideband Right LD.....	1
3	S65074	Wear Guard - Claded	1
4	S56483	IP (Injected Polymer) Right Sideband Seed Boot	1
5	W-477	Hex Bolt - 3/8 x 1 1/2 Lg.....	2
6	S47076	Secondary Hose Grommet - 15/16 ID Hose - Prior to 2023.....	2
7	*****	Liquid Tube - 1/4 OD - See Liquid Kit Supplier for Tube.....	1
8	*****	Injector Tube - 1/8 OD - See NH3 Kit Supplier for Tube	1
9	S48814	Compression Fitting - 1/8 x 1/8	1
	S72323	Forged Sideband Boot Kit - Right IP - LD- (Contains Items 1, 2, 3, 4 & 5)	1

Seed Boot Single Shoot

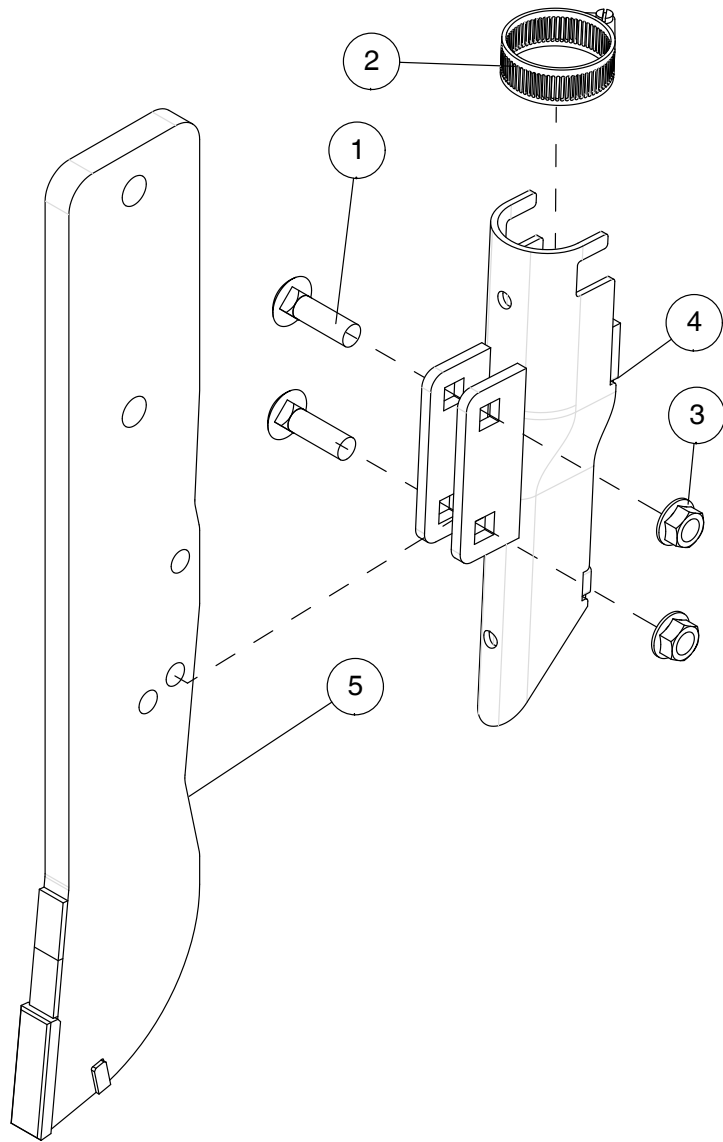

Item	Part No.	Description	Qty
1	D-5260	Carriage Bolt - 3/8 x 1-1/4 Lg	2
2	N11470	Hose Clamp	1
3	S27987	Center Lock Flange Lock Nut - 3/8	2
4	S42865	Single Shoot Boot	1
5	S72310	Forged Shank.....	1
	S72325	Forged Single Shoot Assembly - (Includes Items 1, 3, 4 and 5)	

Seed Boot Single Shoot 3" Spreader

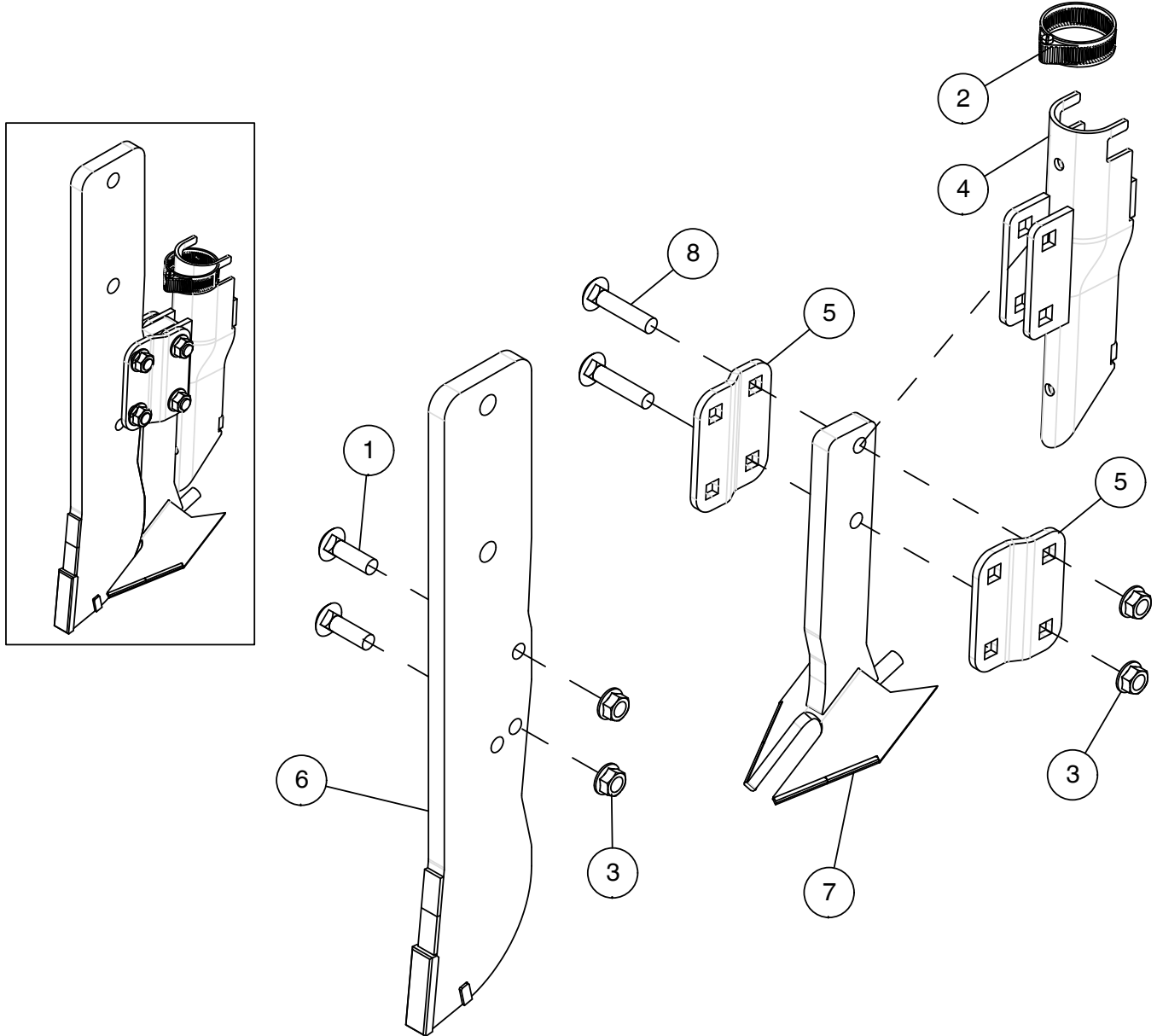

Item	Part No.	Description	Qty
1	D-5260	Carriage Bolt - 3/8 x 1-1/4 Lg	2
2	N11470	Hose Clamp	1
3	S27987	Center Lock Flange Lock Nut - 3/8	4
4	S42865	Single Shoot Boot	1
5	S45269	Mounting Plate	2
6	S72310	Forged Shank.....	1
7	S47337	3" Wear Shovel	1
8	S31980	Carriage Bolt - 3/8 x 1-3/4 Lg	2

Seed Boot Double Shoot - Paired Row

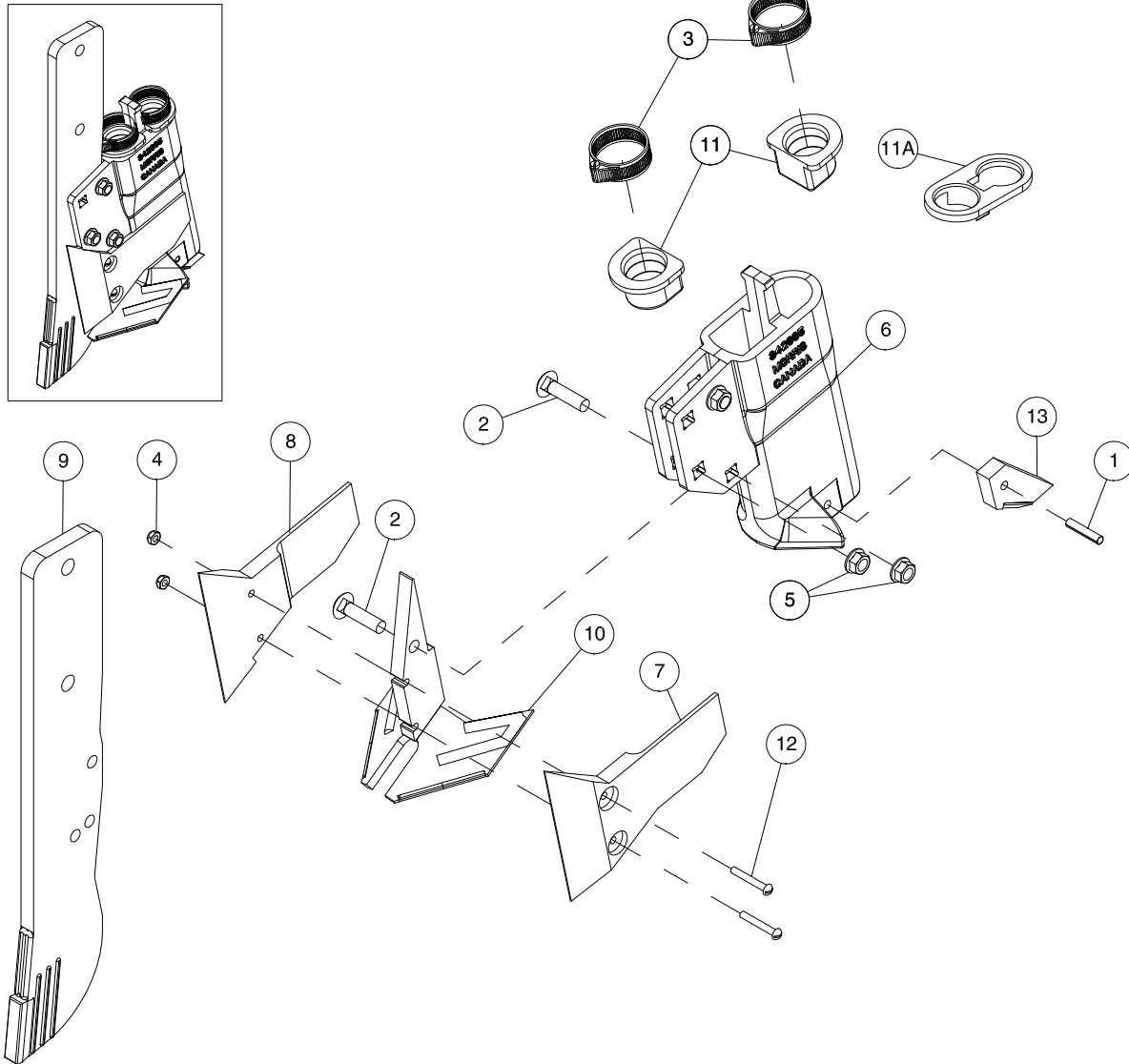

Item	Part No.	Description	Qty
1	D-5243	Roll Pin.....	1
2	D-5261	Carriage Bolt - 3/8 x 1-1/2 Lg	3
3	N11470	Hose Clamp	2
4	N37787	Nylon Insert Locknut - #10-24	2
5	S27987	Center Lock Flange Lock Nut - 3/8	3
6	S42965	Cast Double Shoot Boot	1
7	S45312	Mud Guard Option Left.....	1
8	S45313	Mud Guard Option Right	1
9	S72310	Forged Shank.....	1
10	S45470	Paired Row Shovel.....	1
11	S47076	Secondary Hose Grommet Option - 15/16 ID Hose.....	2
11A	S50245	Secondary Hose Grommet Option - 1.125 ID Hose	
12	S47128	Machine Screw - #10-24 x 1 3/8.....	2
13	S47980	Carbide Wear Tail.....	1
	S46181	Kit - Mud Guards (Includes Items 4, 7, 8, and 12)	

Seed Boot Double Shoot - High Pressure NH3 Kit

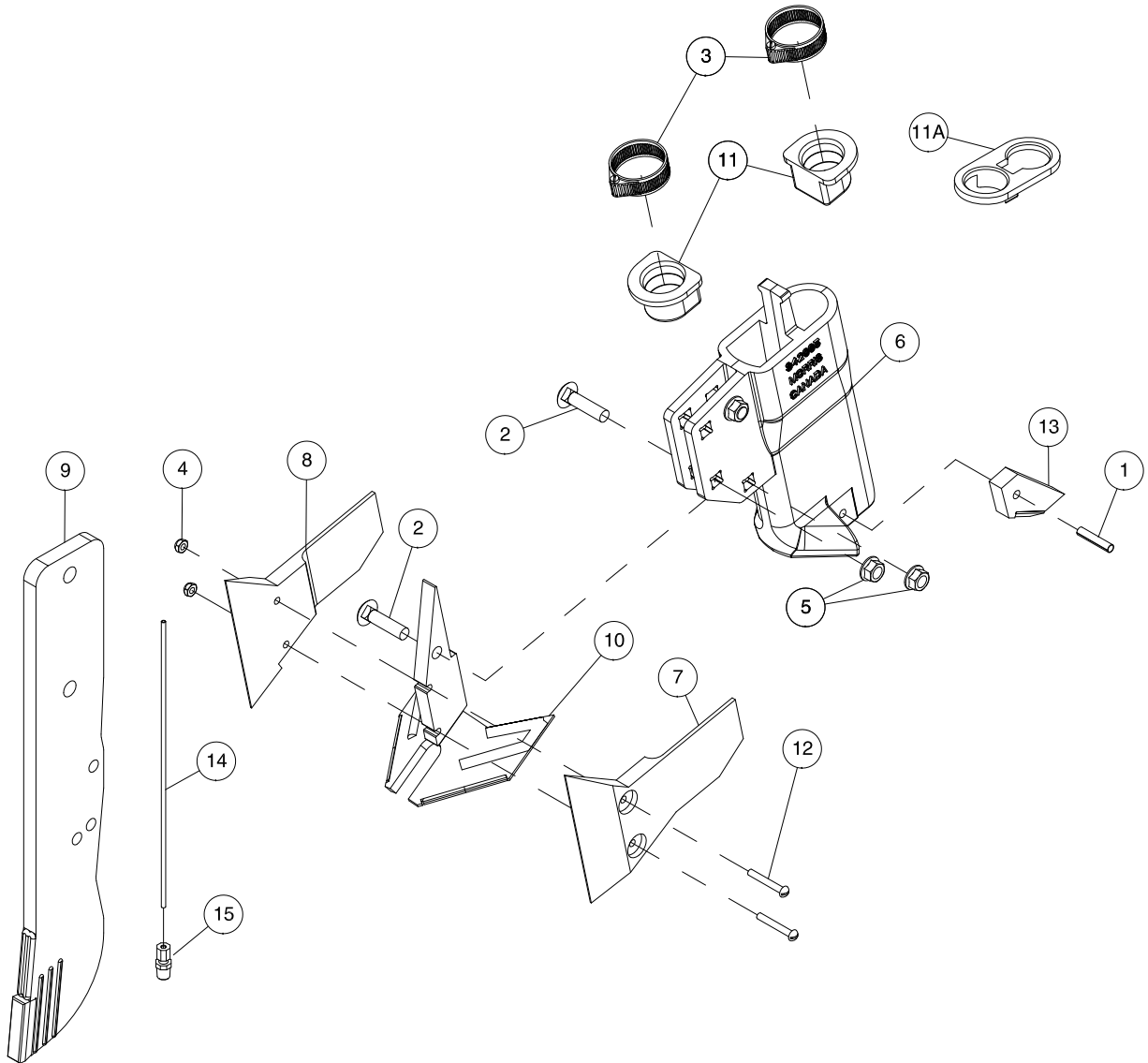

Item	Part No.	Description	Qty
1	D-5243	Roll Pin.....	1
2	D-5261	Carriage Bolt - 3/8 x 1-1/2 Lg	3
3	N11470	Hose Clamp	2
4	N37787	Nylon Insert Locknut - #10-24	2
5	S27987	Center Lock Flange Lock Nut - 3/8	3
6	S42965	Cast Double Shoot Boot	1
7	S45312	Mud Guard Option Left.....	1
8	S45313	Mud Guard Option Right.....	1
9	S72310	Forged Shank.....	1
10	S45470	Paired Row Shovel.....	1
11	S47076	Secondary Hose Grommet Option - 15/16 ID Hose	2
11A	S50245	Secondary Hose Grommet Option - 1.125 ID Hose	
12	S47128	Machine Screw - #10-24 x 1 3/8.....	2
13	S47980	Carbide Wear Tail.....	1
14	S48813	NH3 Injector Tube - 1/8 OD x 10 Lg T304 Stainless Tube	1
15	S48814	Compression Fitting - 1/8 Tube x 1/8 Male Pipe	1
	S46384	Kit - High Pressure Anhydrous (Includes Items 15 and 16)	

Seed Boot Double Shoot - Side Band - Left

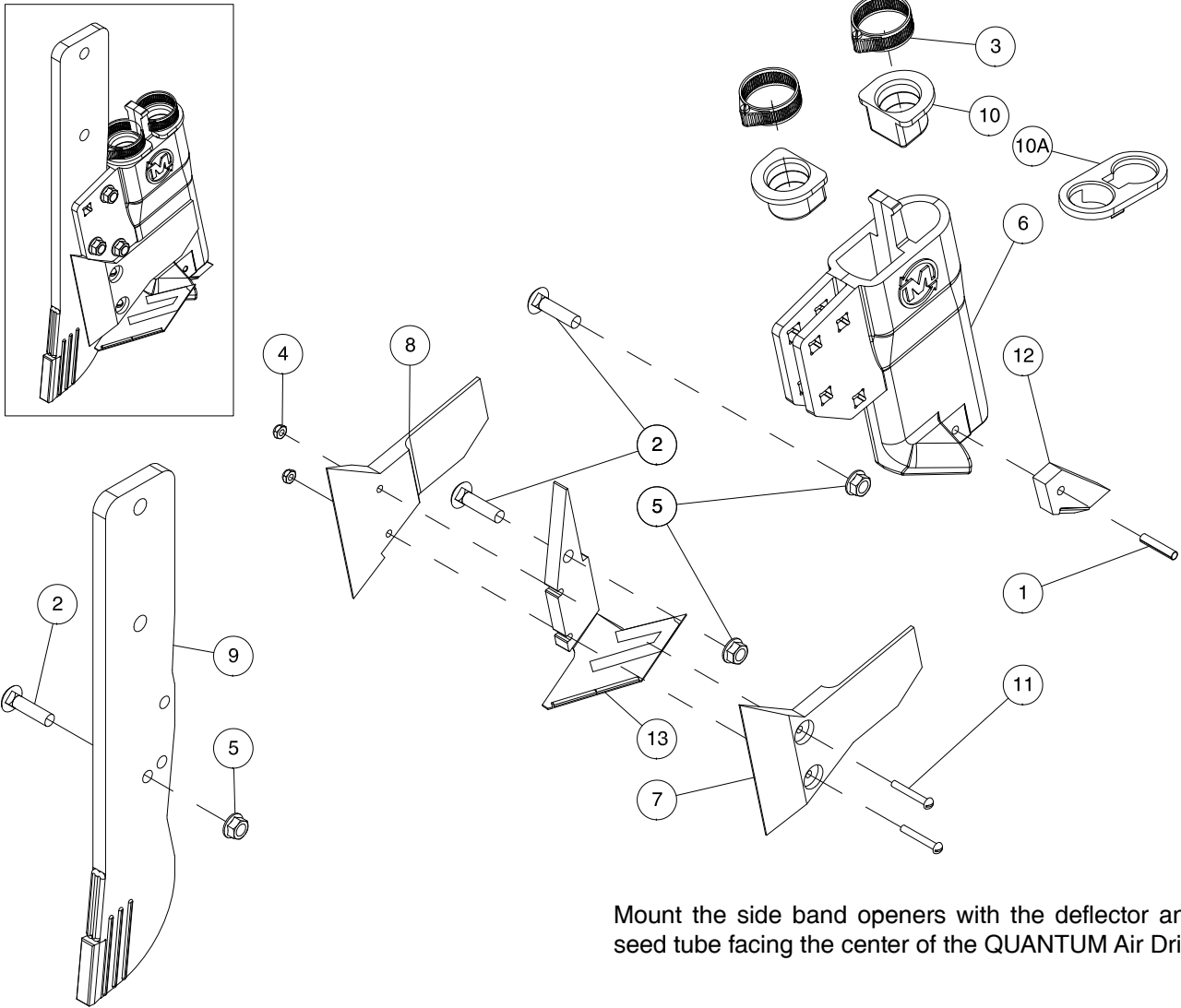

Mount the side band openers with the deflector and seed tube facing the center of the QUANTUM Air Drill.

Item	Part No.	Description	Qty
1	D-5243	Roll Pin.....	1
2	D-5261	Carriage Bolt - 3/8 x 1-1/2 Lg	3
3	N11470	Hose Clamp	2
4	N37787	Nylon Insert Locknut - #10-24	2
5	S27987	Center Lock Flange Lock Nut - 3/8	3
6	S44977	Cast Double Shoot Boot - Side Band - Left.....	1
6A	S51469	Cast Double Shoot Boot - Side Band - Left - Carbide	
7	S45312	Mud Guard Option Left.....	1
8	S45313	Mud Guard Option Right	1
9	S72310	Forged Shank.....	1
10	S47076	Secondary Hose Grommet Option - 15/16 ID Hose	2
10A	S50245	Secondary Hose Grommet Option - 1.125 ID Hose	
11	S47128	Machine Screw - #10-24 x 1-3/8.....	2
12	S47980	Carbide Wear Tail.....	1
13	S49536	Side Band Shovel.....	1
	S46181	Kit - Mud Guards (Includes Items 4, 7, 8, and 11)	

Seed Boot Double Shoot - Side Band Boot - Right

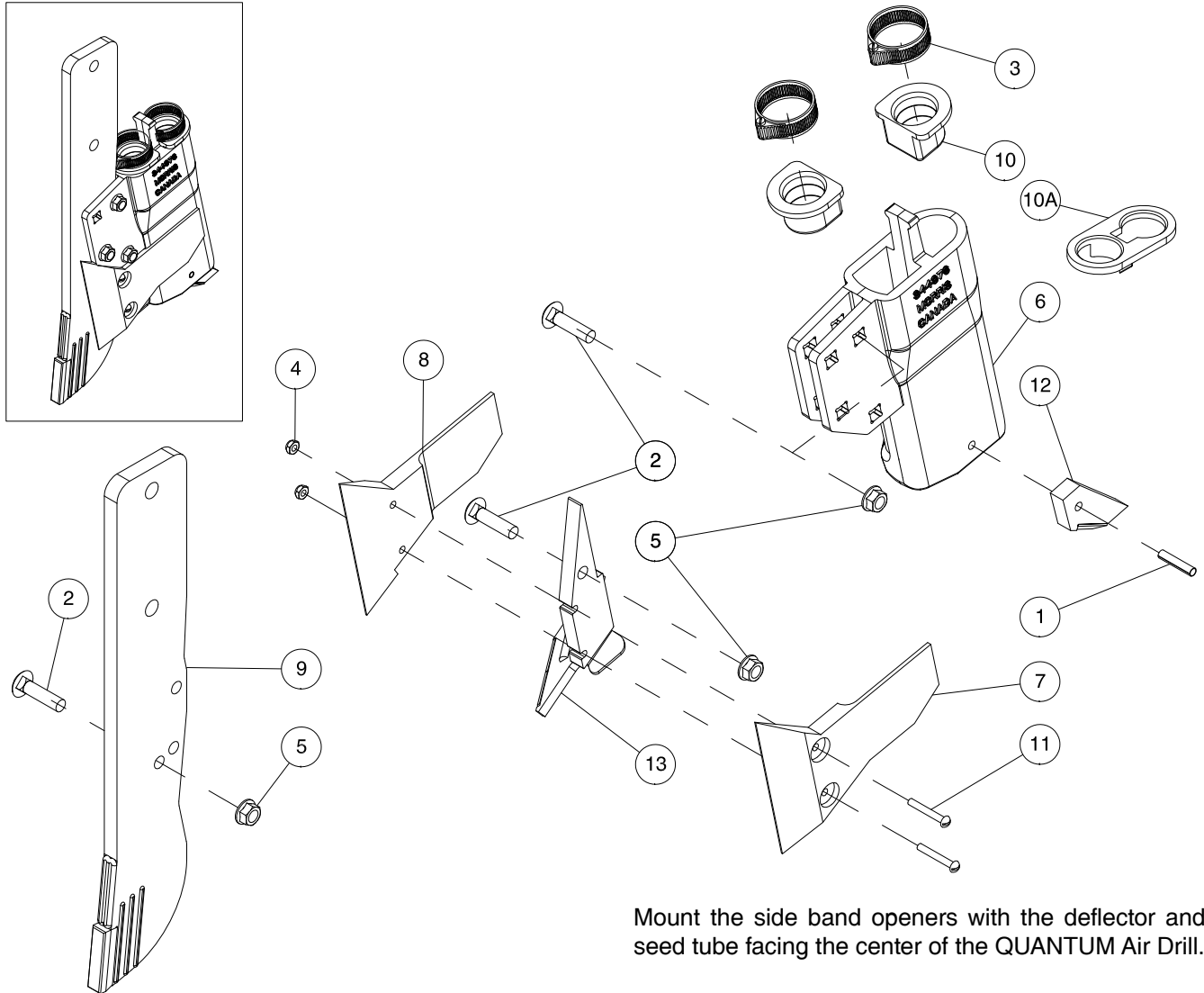

Mount the side band openers with the deflector and seed tube facing the center of the QUANTUM Air Drill.

Item	Part No.	Description	Qty
1	D-5243	Roll Pin - 1/4 x 1 1/4 Lg.....	1
2	D-5261	Carriage Bolt - 3/8 x 1-1/2 Lg	3
3	N11470	Hose Clamp	2
4	N37787	Nylon Insert Locknut - #10-24	2
5	S27987	Center Lock Flange Lock Nut - 3/8	3
6	S44976	Cast Double Shoot Boot - Side Band - Right	1
6A	S51470	Cast Double Shoot Boot - Side Band - Right - Carbide	
7	S45312	Mud Guard Option Left.....	1
8	S45313	Mud Guard Option Right	1
9	S72310	Forged Shank.....	1
10	S47076	Secondary Hose Grommet Option - 15/16 ID Hose	2
10A	S50245	Secondary Hose Grommet Option- 1.125 ID Hose	
11	S47128	Machine Screw - #10-24 x 1-3/8.....	2
12	S47980	Carbide Wear Tail.....	1
13	S49537	Side Band Shovel - Right.....	1
	S46181	Kit - Mud Guards (Includes Items 4, 7, 8, and 11)	

Soil Levelers - Prior to 2020 -

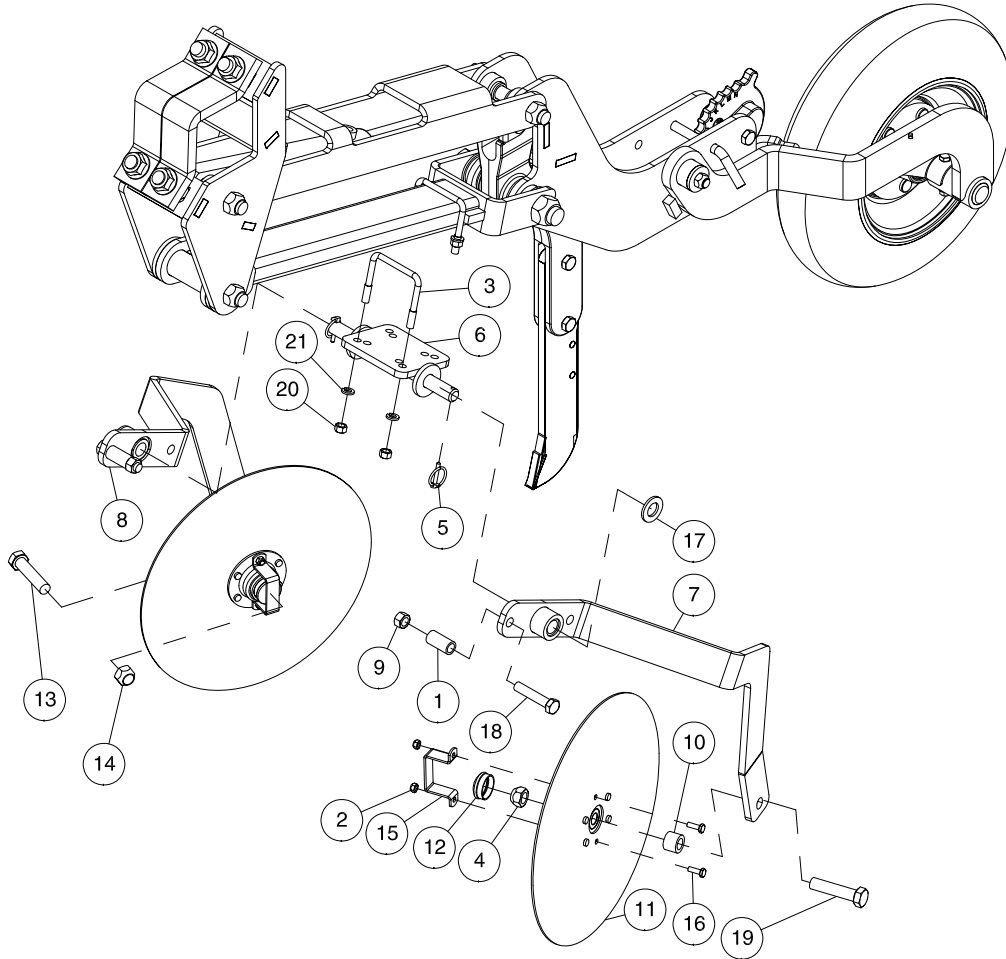

Item	Part No.	Description	Qty
1	A28898	Stop Pipe - 3/4 OD x .532 ID	2
2	N15757	Locknut - 1/4 Unitorque.....	4
3	N27709	Ubolt - 3/8 x 3 x 2 3/4 Lg.....	2
4	S-1197	Locknut - 5/8 Unitorque.....	1
5	S42294	Lynch Pin - 3/16 Dia x 1/14 Lg	2
6	S44440	Mounting Bracket	1
7	S44444	Soil Leveller Arm - Left (Includes Bushing C26525).....	1
8	S44445	Soil Leveller Arm - Right (Includes Bushing C26525)	1
9	S47110	Hex Nut - 1/2 Center Lock.....	2
10	S47395	Spacer Bushing - 1 OD x .627 ID.....	2
11	S47687	14" Closing Disc Assy - Includes Dust Cap Item# 12.....	2
12	S47692	Dust Cap	2
13	S47693	Hex Bolt Lht - 5/8 x 2 3/4 Lg.....	1
14	S47694	Locknut Lht - 5/8 Unitorque.....	1
15	S47695	Dust Cap Retainer.....	2
16	W-469	Hex Head - 1/4 x 3/4 Lg	4
17	W-476	Flat Washer - 3/4.....	2
18	W-490	Hex Bolt - 1/2 x 2 1/2 Lg.....	3
19	W-502	Hex Bolt - 5/8 x 2 3/4 Lg.....	1
20	W-514	Hex Nut - 3/8.....	4
21	W-523	Lockwasher - 3/8.....	4
	S46334	Soil Leveler Kit Contour (Contains All Items)	

Section 4: Hydraulics

Section Contents

Wing Lift Hydraulics	4-2
25 & 31 Ft Model - Prior to 2017.....	4-2
25 & 31 Ft Model - 2017 to Present.....	4-4
41 Ft Model - Prior to September 2012	4-6
41 Ft Model - September 2012 to Present.....	4-8
51 Ft, 61 Ft and 71 Ft Models - Prior to September 2012	4-10
51 Ft, 61 Ft and 71 Ft Models - September 2012 to Present.....	4-12
80 Ft and 86 Ft Models - Prior to September 2013	4-14
80 Ft, 86 Ft and 90 Ft - September 2013 to Present	4-16
Wing Valve - 80 Ft, 86 Ft and 90 Ft.....	4-18
Accumulator and Hitch Hydraulics	4-20
25 & 31 Ft - Prior to 2016	4-20
25 & 31 Ft - 2016 to Present.....	4-22
41 to 86 Ft - Prior to September 2012	4-24
41 to 90 Ft - September 2012 to 2015	4-26
41 to 90 Ft - 2016 to Present	4-28
41 to 90 Ft - High Speed.....	4-30
Active Hydraulic Kit - Optional	4-32
Case Drain Tow Behind Carts - 2016 to Present	4-34
Opener Hydraulics	4-36
10 inch Spacing - 25 & 31 Ft Model - Prior to 2020.....	4-36
10 inch Spacing - 25 & 31 Ft Model - 2020 to Present.....	4-38
10 inch Spacing - 41 Ft to 71 Ft	4-40
12 inch Spacing - 25 & 31 Ft Model - Prior to 2020.....	4-42
12 inch Spacing - 25 & 31 Ft Model - 2020 to Present.....	4-44
12 inch Spacing - 41 Ft to 71 Ft.....	4-46
12 inch Spacing - 80 Ft, 86 Ft and 90 Ft - Prior to 2020	4-48
12 inch Spacing - 80 Ft - 2020 to Present.....	4-50
12 inch Spacing - 90 Ft - 2020 to Present.....	4-52
12 inch Spacing - 41 Ft to 90 Ft - High Speed	4-54
Tow Between Air Cart - 7000 Series - Prior to 2016.....	4-56
Tow Between Air Cart - 8XL Series - Prior to 2016.....	4-57
Pressure Control	4-58
Digital Gauge - Standard Passive System.....	4-58
JEM Pressure Control System - for Active Hydraulic Option	4-59
9 Series Apollo - for Active Hydraulic Option.....	4-60
10 Series Apollo - for Active Hydraulic Option	4-62

Wing Lift Hydraulics 25 & 31 Ft Model - Prior to 2017

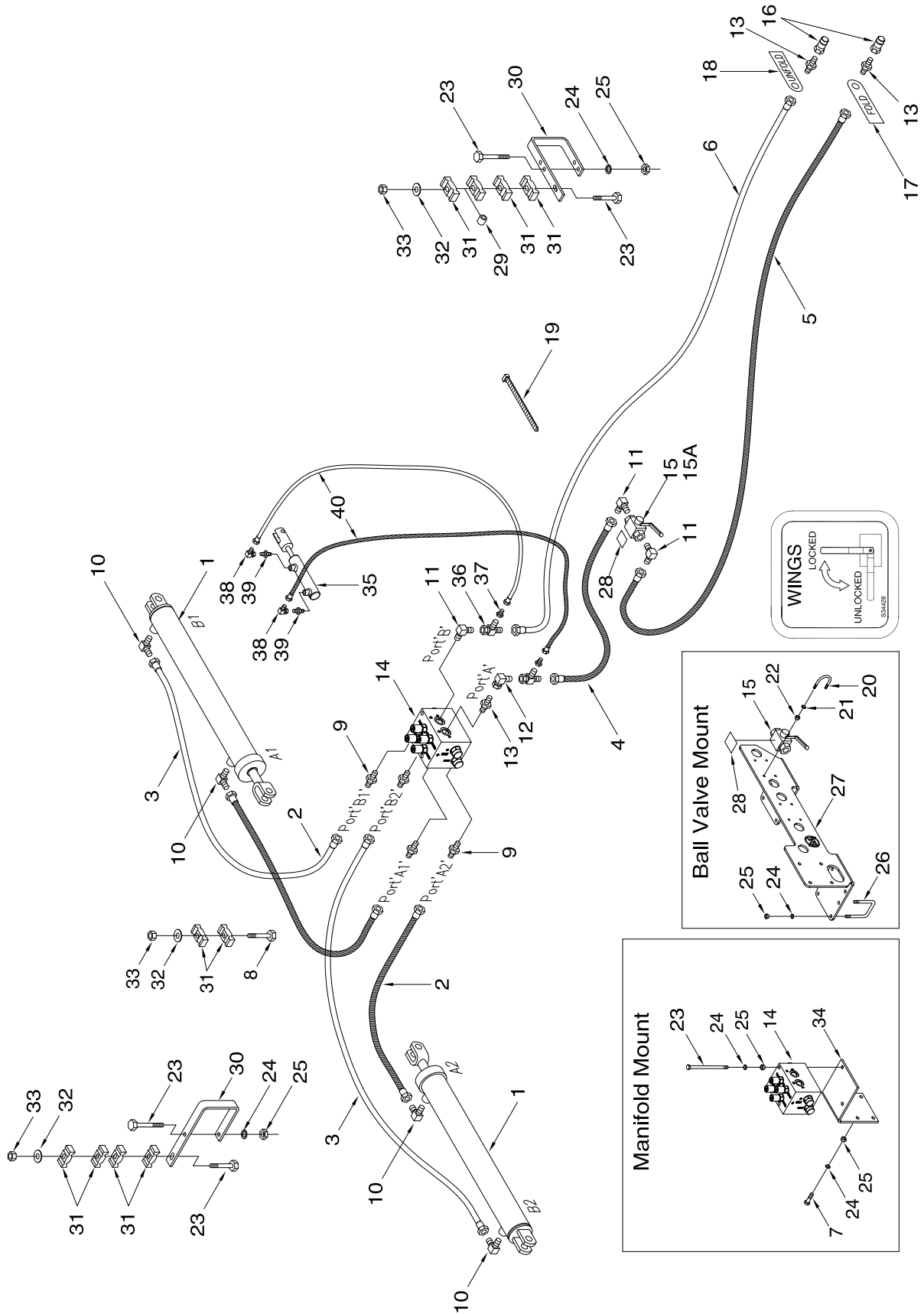

Wing Lift Hydraulics - 25 & 31 Ft Model - Prior to 2017

Item	Part No.	Description	Qty
1	C34442	Cylinder - 4 1/2 x 30.....	2
2	S22406	Hyd. Hose - 1/4 x 72 - 9/16-18 FJIC x 9/16-18 FJIC Ends	2
3	H18267	Hyd. Hose - 1/4 x 96 - 9/16-18 FJIC x 9/16-18 FJIC Ends	2
4	C26343	Hyd. Hose - 1/2 x 162 - 7/8-14 FJIC	1
5	C26337	Hyd. Hose - 1/2 x 276 - 7/8-14 FJIC Ends	1
6	C29565	Hyd. Hose - 1/2 x 360 - 7/8-14 FJIC Ends.....	1
7	W-187	Hex Bolt - 3/8 x 1 1/4 Lg	4
8	W-480	Hex Bolt - 3/8 x 2 1/2 Lg	4
9	C15348	Connector - 3/4-16 MORB x 9/16-18 MJIC	4
10	N16143	Elbow 90 deg - 9/16-18 MJIC x 9/16-18 MORB	4
11	C24585	Elbow 90 deg - 7/8-14 MJIC x 3/4-16 MORB.....	3
12	K-5806	Elbow 90 deg - 7/8-14 FJIC x 7/8-14 MJIC.....	1
13	C14840	Reducer - 3/4-16 MORB x 7/8-14 MJIC	3
14	C53849	Manifold - Pressure Compensated Flow Control.....	1
15	N42880	Valve - 2 Way Ball.....	1
15A	N42881	Handle - Valve	1
16	N34443	Male Pioneer Tip - 3/4-16 FORB.....	2
17	S29960	Tag - Hose ID - Wing Lift - FOLD.....	1
18	S29961	Tag - Hose ID - Wing Lift - UNFOLD	1
19	S13336	Nylon Tie Strap - 1/2 x 28 1/4.....	12
19A	D-4838	Nylon Tie Strap - 1/2 x 14 1/2.....	8
19B	D-4951	Nylon Tie Strap - 1/2 x 7 3/8.....	70
20	N34319	U-Bolt - 1/4 x 1 1/2 x 1 3/4 Lg	2
21	W-521	Lockwasher - 1/4.....	4
22	W-512	Hex Nut - 1/4.....	4
23	C-3918	Hex Bolt - 3/8 x 5 Lg.....	8
24	W-523	Lockwasher - 3/8.....	14
25	W-514	Hex Nut - 3/8	14
26	D12714	U-Bolt - 3/8 x 2 x 2 3/4 Lg	4
27	S47642	Multi-Valve Mounting Plate.....	1
28	S34428	Decal - Wings Lock	1
29	N16257	Bushing - Spacer	2
30	C14411	Oil Line Bracket.....	4
31	C-4698	Oil Line Clamp	16
32	W-538	Flatwasher - 3/8	4
33	M-3388	Locknut - 3/8	4
34	S39565	Mounting Bracket - Valve.....	1
35	N47712	Cylinder - 1 x 3 3/8 - Wing Lock (Seal Kit N60900).....	1
36	H18746	Tee - Swivel - (2) 7/8-14 MJIC x (1) 7/8-14 FJIC	2
37	F10384	Connector - 9/16-18 MJIC x 7/8-14 FJIC	2
38	S29967	90 Elbow - Swivel - 9/16-18 FJIC x 9/16-18 MJIC.....	2
39	S34115	Connector - 9/16-18 MJIC x 7/16-20 MORB	2
40	S42969	Hyd Hose - 3/8 x 36 Lg w/ #6 9/16-18 FJIC.....	2

Wing Lift Hydraulics 25 & 31 Ft Model - 2017 to Present

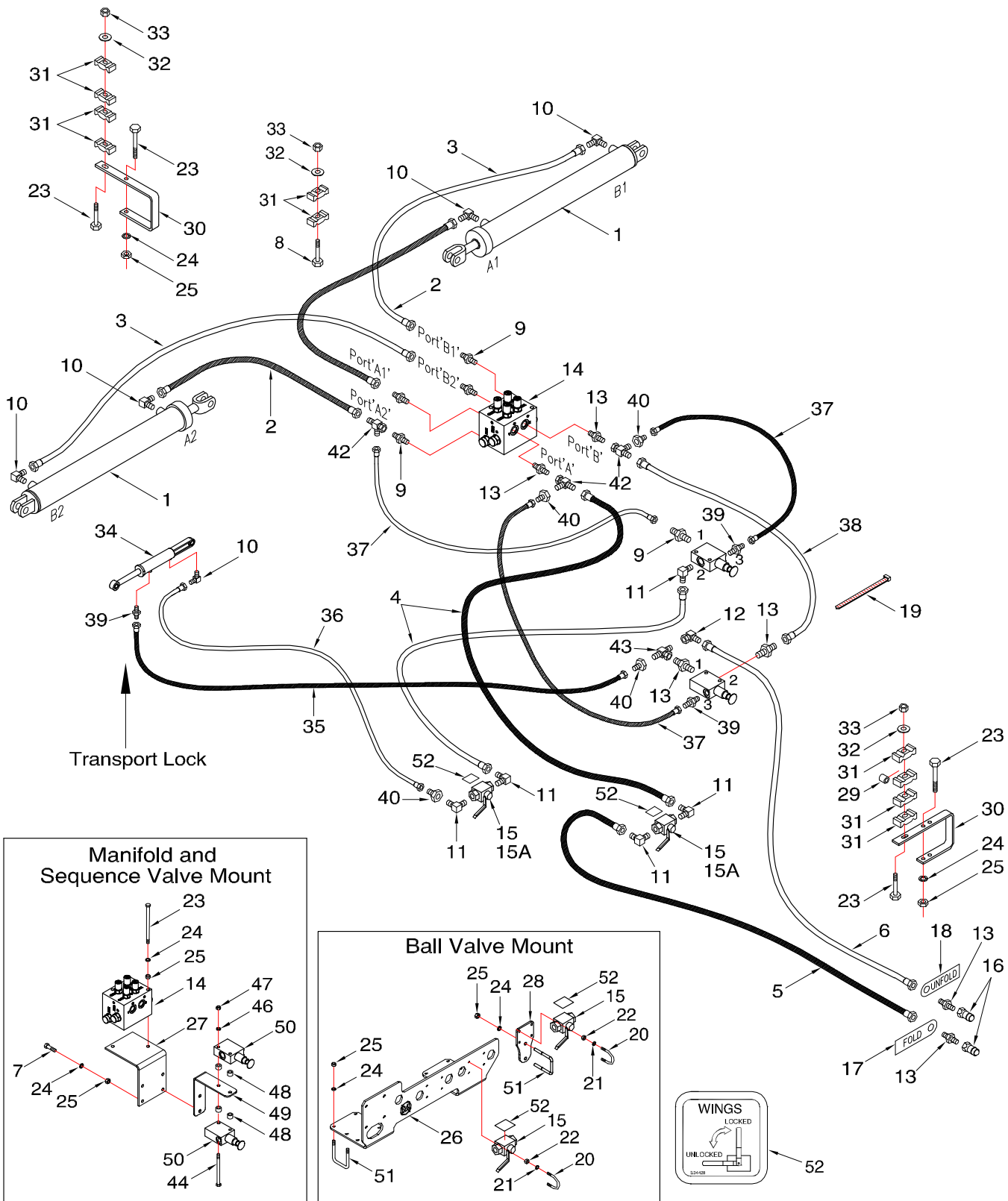

Wing Lift Hydraulics - 2017 to Present

Item	Part No.	Description	Qty
1	C34442	Cylinder - 4 1/2 x 30.....	2
2	S22406	Hyd. Hose - 1/4 x 72 - 9/16-18 FJIC x 9/16-18 FJIC Ends	2
3	H18267	Hyd. Hose - 1/4 x 96 - 9/16-18 FJIC x 9/16-18 FJIC Ends	2
4	C26343	Hyd. Hose - 1/2 x 162 - 7/8-14 FJIC	2
5	C26337	Hyd. Hose - 1/2 x 276 - 7/8-14 FJIC Ends	1
6	C29565	Hyd. Hose - 1/2 x 360 - 7/8-14 FJIC Ends	1
7	W-477	Hex Bolt - 3/8 x 1 1/2 Lg	4
8	W-480	Hex Bolt - 3/8 x 2 1/2 Lg	4
9	C15348	Connector - 3/4-16 MORB x 9/16-18 MJIC	6
10	N16143	Elbow 90 deg - 9/16-18 JIC x 9/16-18 MORB	5
11	C24585	90 Elbow - 7/8-14 MJIC x 3/4-16 MORB	5
11	C24585	Elbow 90 deg - 7/8-14 MJIC x 3/4-16 MORB	3
12	K-5806	Elbow 90 deg - 7/8-14 FJIC x 7/8-14 MJIC	2
13	C14840	Connector - 3/4-16 MORB x 7/8-14 MJIC	6
14	C53849	Manifold - Pressure Compensated Flow Control	1
15	N42880	Valve - 2 Way Ball.....	2
15A	N42881	Handle - Valve	2
16	N34443	Male Pioneer Tip - 3/4-16 FORB	2
17	C29960	Tag - Hose ID - Wing Lift - FOLD.....	1
18	C29961	Tag - Hose ID - Wing Lift - UNFOLD	1
19	S13336	Nylon Tie Strap - 1/2 x 28 1/4.....	12
19A	D-4838	Nylon Tie Strap - 1/2 x 14 1/2.....	8
19B	D-4951	Nylon Tie Strap - 1/2 x 7 3/8.....	70
20	N34319	U-Bolt - 1/4 x 1 1/2 x 1 3/4 Lg	4
21	W-521	Lockwasher - 1/4.....	8
22	W-512	Hex Nut - 1/4	8
23	C-3918	Hex Bolt - 3/8 x 5 Lg.....	8
24	W-523	Lockwasher - 3/8.....	16
25	W-514	Hex Nut - 3/8	16
26	S47642	Multi-Valve Mounting Plate.....	1
27	S39565	Mounting Bracket - Valve.....	1
28	S39546	Mount Plate - Ball Valve	1
29	N16257	Bushing - 0.385 ID x 5/8 OD x 5/8 Lg	2
30	C14411	Oil Line Bracket.....	4
31	C-4698	Oil Line Clamp	16
32	W-538	Flatwasher - 3/8	4
33	M-3388	Locknut - 3/8	4
34	C51153	Cylinder - 1 3/4 Bore x 4 Stroke	1
35	C26339	Hyd Hose - 1/4 x 120 Lg w/9/16-18 FJIC	1
36	D15435	Hyd Hose - 1/4 x 276 Lg w/9/16-18 FJIC	1
37	N49111	Hyd Hose - 3/8 x 15 Lg w/9/16-18 FJIC	3
38	C-4468	Hyd Hose - 1/2 x 24 Lg w/7/8-14 FJIC.....	1
39	N29358	Connector - 9/16-18 MJIC x 9/16-18 MORB.....	3
40	F10384	Connector - 7/8-14 FJIC x 9/16-18 (#06) MJIC.....	3
41	C-4403	Tee - Swivel - (2) 9/16-18 MJIC x (1) 9/16-18 FJIC (MMF).....	1
42	H18746	Tee - Swivel - (2) 7/8-14 MJIC x (1) 7/8-14 FJIC (MMF)	2
43	F24559	Tee - (1) 7/8-14 FJIC x (2) 7/8-14 MJIC (MFM).....	1
44	C26820	Hex Bolt - 5/16 x 4 1/2 Lg.....	2
45	S-1198	Flatwasher - 5/16	4
46	W-522	Lockwasher - 5/16.....	2
47	W-513	Hex Nut - 5/16	2
48	N19155	Bushing - 3/8 ID x 5/8 OD x 1/2 Lg	4
49	N62238	Mount - Sequence Valves.....	1
50	S22073	Sequence Valve	2
51	D12714	U-Bolt - 3/8 x 2 x 2 3/4 Lg	5
52	S34428	Decal - Wings Lock	2

Wing Lift Hydraulics 41 Ft Model - Prior to September 2012

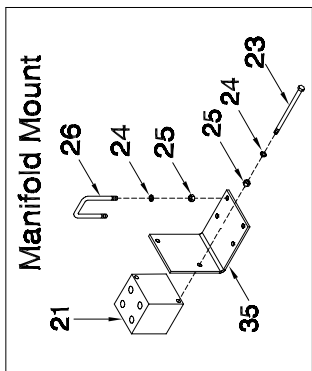
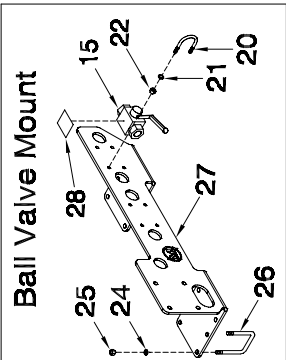
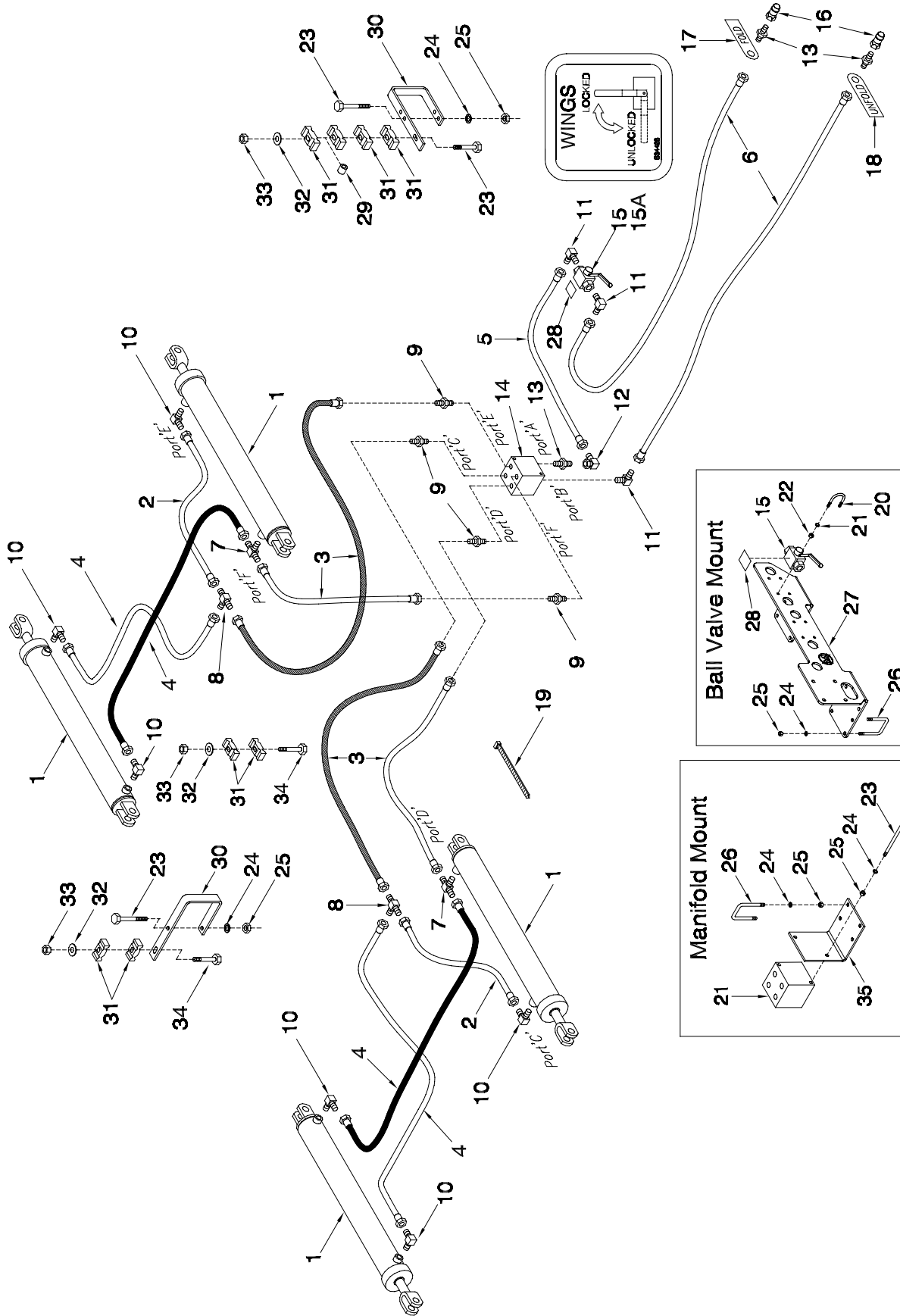

Wing Lift Hydraulics - 41 Ft Model - Prior to September 2012

Item	Part No.	Description	Qty
1	C34442	Cylinder - 4 1/2 x 30.....	4
2	C26438	Hyd. Hose - 1/4 x 30 - 9/16-18 FJIC x 9/16-18 FJIC Ends	2
3	S22406	Hyd. Hose - 1/4 x 72 - 9/16-18 FJIC x 9/16-18 FJIC Ends	4
4	S39503	Hyd. Hose - 1/4 x 132 - 9/16-18 FJIC x 9/16-18 FJIC Ends.....	4
5	F-4565	Hyd. Hose - 1/2 x 60 - 7/8-14 FJIC Ends.....	1
6	C26337	Hyd. Hose - 1/2 x 276 - 7/8-14 FJIC Ends.....	2
7	N31908	Tee - (2) 9/16-18 MJIC x (1) 9/16-18 MORB.....	2
8	C-4393	Tee - (3) 9/16-18 MJIC.....	2
9	C15348	Male Connector - 3/4-16 MORB x 9/16-18 MJIC.....	4
10	N16143	Elbow 90 deg - 9/16-18 MJIC x 9/16-18 MORB	6
11	C24585	Elbow 90 deg - 7/8-14 MJIC x 3/4-16 MORB	3
12	K-5806	Elbow 90 deg - 7/8-14 FJIC x 7/8-14 MJIC.....	1
13	C14840	Reducer - 3/4-16 MORB x 7/8-14 MJIC	3
14	C53849	Manifold - Pressure Compensated Flow Control.....	1
15	N42880	Valve - 2 Way Ball.....	1
15A	N42881	Handle - Valve	1
16	N34443	Male Pioneer Tip - 3/4-16 FORB.....	2
17	S29960	Tag - Hose ID - Wing Lift - FOLD.....	1
18	S29961	Tag - Hose ID - Wing Lift - UNFOLD	1
19	S13336	Nylon Tie Strap - 1/2 x 28 1/4.....	12
19A	D-4838	Nylon Tie Strap - 1/2 x 14 1/2.....	8
19B	D-4951	Nylon Tie Strap - 1/2 x 7 3/8.....	70
20	N34319	U-Bolt - 1/4 x 1 1/2 x 1 3/4 Lg	2
21	W-521	Lockwasher - 1/4.....	4
22	W-512	Hex Nut - 1/4.....	4
23	C-3918	Hex Bolt - 3/8 x 5 Lg.....	12
24	W-523	Lockwasher - 3/8.....	18
25	W-514	Hex Nut - 3/8.....	18
26	D12714	U-Bolt - 3/8 x 2 x 2 3/4 Lg	3
27	S47642	Multi-Valve Mounting Plate.....	1
28	S34428	Decal - Wings Lock	1
29	N16257	Bushing - Spacer	3
30	C14411	Oil Line Bracket.....	7
31	C-4698	Oil Line Clamp	28
32	W-538	Flatwasher - 3/8.....	15
33	M-3388	Locknut - 3/8	15
34	W-480	Hex Bolt - 3/8 x 2 1/2.....	8
35	S39565	Mounting Bracket - Valve.....	1

Wing Lift Hydraulics 41 Ft Model - September 2012 to Present

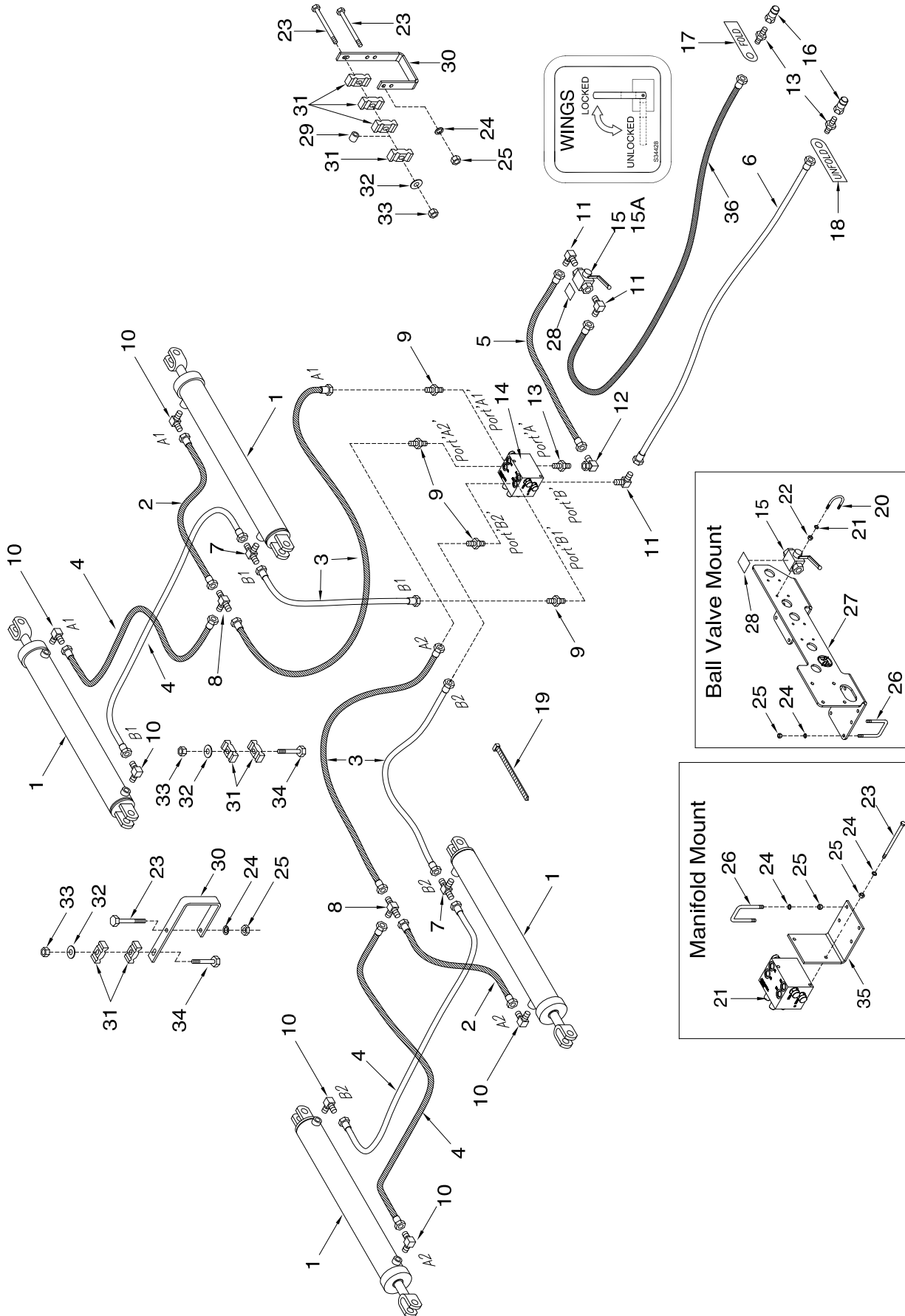

Wing Lift Hydraulics - 41 Ft Model - September 2012 to Present

Item	Part No.	Description	Qty
1	C34442	Cylinder - 4 1/2 x 30.....	4
2	C26438	Hyd. Hose - 1/4 x 30 - 9/16-18 FJIC x 9/16-18 FJIC Ends	2
3	S22406	Hyd. Hose - 1/4 x 72 - 9/16-18 FJIC x 9/16-18 FJIC Ends	4
4	S39503	Hyd. Hose - 1/4 x 132 - 9/16-18 FJIC x 9/16-18 FJIC Ends.....	4
5	C26259	Hyd. Hose - 1/2 x 108 - 7/8-14 FJIC Ends	1
6	C26337	Hyd. Hose - 1/2 x 276 - 7/8-14 FJIC Ends	1
7	N31908	Tee - (2) 9/16-18 MJIC x (1) 9/16-18 MORB.....	2
8	C-4393	Tee - (3) 9/16-18 MJIC.....	2
9	C15348	Male Connector - 3/4-16 MORB x 9/16-18 MJIC.....	4
10	N16143	Elbow 90 deg - 9/16-18 MJIC x 9/16-18 MORB	6
11	C24585	Elbow 90 deg - 7/8-14 MJIC x 3/4-16 MORB	3
12	K-5806	Elbow 90 deg - 7/8-14 FJIC x 7/8-14 MJIC	1
13	C14840	Reducer - 3/4-16 MORB x 7/8-14 MJIC	3
14	C53849	Manifold - Pressure Compensated Flow Control	1
15	N42880	Valve - 2 Way Ball.....	1
15A	N42881	Handle - Valve	1
16	N34443	Male Pioneer Tip - 3/4-16 FORB.....	2
17	S29960	Tag - Hose ID - Wing Lift - FOLD.....	1
18	S29961	Tag - Hose ID - Wing Lift - UNFOLD	1
19	S13336	Nylon Tie Strap - 1/2 x 28 1/4.....	12
19A	D-4838	Nylon Tie Strap - 1/2 x 14 1/2.....	8
19B	D-4951	Nylon Tie Strap - 1/2 x 7 3/8.....	70
20	N34319	U-Bolt - 1/4 x 1 1/2 x 1 3/4 Lg	2
21	W-521	Lockwasher - 1/4.....	4
22	W-512	Hex Nut - 1/4.....	4
23	C-3918	Hex Bolt - 3/8 x 5 Lg.....	12
24	W-523	Lockwasher - 3/8.....	18
25	W-514	Hex Nut - 3/8	18
26	D12714	U-Bolt - 3/8 x 2 x 2 3/4 Lg	3
27	S47642	Multi-Valve Mounting Plate.....	1
28	S34428	Decal - Wings Lock	1
29	N16257	Bushing - Spacer	3
30	C14411	Oil Line Bracket.....	7
31	C-4698	Oil Line Clamp	28
32	W-538	Flatwasher - 3/8	15
33	M-3388	Locknut - 3/8	15
34	W-480	Hex Bolt - 3/8 x 2 1/2.....	8
35	S39565	Mounting Bracket - Valve.....	1
36	S39539	Hyd. Hose - 1/2 x 330 - 7/8-14 FJIC Ends.....	1

Wing Lift Hydraulics

51 Ft, 61 Ft and 71 Ft Models - Prior to September 2012

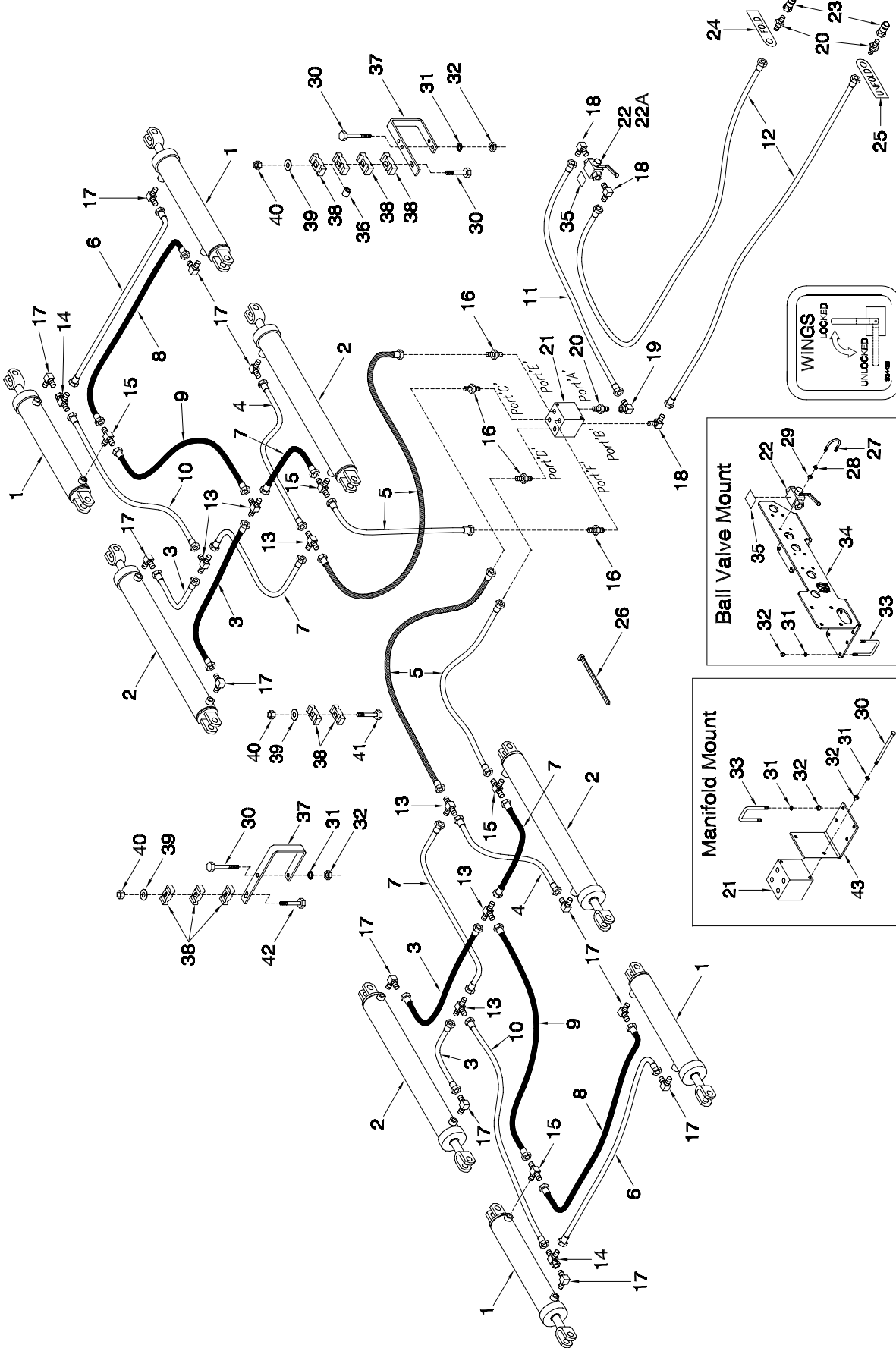

Wing Lift Hydraulics - 51 Ft, 61 Ft and 71 Ft Models - Prior to September 2012

Item	Part No.	Description	Qty
1	C26436	Cylinder - 4 x 18 - 51 ft.....	4
	C34442	Cylinder - 4 1/2 x 30 - 61 ft and 71 ft.....	4
2	C34442	Cylinder - 4 1/2 x 30 - 51 ft.....	4
	C39030	Cylinder - 4 1/2 x 36 - 61 ft.....	4
	C39490	Cylinder - 5 x 36 - 71 ft.....	4
3	C-4552	Hyd. Hose - 1/4 x 24 - 9/16-18 FJIC x 9/16-18 FJIC Ends	4
4	C14835	Hyd. Hose - 1/4 x 36 - 9/16-18 FJIC x 9/16-18 FJIC Ends	2
5	C16652	Hyd. Hose - 1/4 x 60 - 9/16-18 FJIC x 9/16-18 FJIC Ends - 61 ft & 71 ft.....	4
	S22406	Hyd. Hose - 1/4 x 72 - 9/16-18 FJIC x 9/16-18 FJIC Ends - 51 ft	4
6	H18267	Hyd. Hose - 1/4 x 96 - 9/16-18 FJIC x 9/16-18 FJIC Ends	2
7	W21962	Hyd. Hose - 1/4 x 108 - 9/16-18 FJIC x 9/16-18 FJIC Ends.....	4
8	S39503	Hyd. Hose - 1/4 x 132 - 9/16-18 FJIC x 9/16-18 FJIC Ends.....	2
9	D17585	Hyd. Hose - 1/4 x 176 - 9/16-18 FJIC x 9/16-18 FJIC Ends - 51 ft.....	2
	F14658	Hyd. Hose - 1/4 x 150 - 9/16-18 FJIC x 9/16-18 FJIC Ends - 61 ft.....	2
	S13317	Hyd. Hose - 1/4 x 180 - 9/16-18 FJIC x 9/16-18 FJIC Ends - 71 ft.....	2
10	D17845	Hyd. Hose - 1/4 x 198 - 9/16-18 FJIC x 9/16-18 FJIC Ends - 51 ft.....	2
	S13317	Hyd. Hose - 1/4 x 180 - 9/16-18 FJIC x 9/16-18 FJIC Ends - 61 ft.....	2
	C26347	Hyd. Hose - 1/4 x 216 - 9/16-18 FJIC x 9/16-18 FJIC Ends - 71 ft.....	2
11	F-4565	Hyd. Hose - 1/2 x 60 - 7/8-14 FJIC Ends - 51 ft.....	1
	N19345	Hyd. Hose - 1/2 x 132 - 7/8-14 FJIC Ends - 61 ft and 71 ft	1
12	C26337	Hyd. Hose - 1/2 x 276 - 7/8-14 FJIC Ends - 51 ft.....	2
	S39523	Hyd. Hose - 1/2 x 420 - 7/8-14 FJIC Ends - 61 ft and 71 ft	2
13	C-4393	Tee - (3) 9/16-18 MJIC.....	6
14	C-4403	Swivel Tee - (2) 9/16-18 MJIC x (1) 9/16-18 FJIC (MMF)	2
15	N31908	Swivel Tee - (2) 9/16-18 MJIC x (1) 9/16-18 MORB.....	4
16	C15348	Male Connector - 3/4-16 MORB x 9/16-18 MJIC.....	4
17	N16143	Elbow 90 deg - 9/16-18 MJIC x 9/16-18 MORB	12
18	C24585	Elbow 90 deg - 7/8-14 MJIC x 3/4-16 MORB	3
19	K-5806	Elbow 90 deg - 7/8-14 FJIC x 7/8-14 MJIC	1
20	C14840	Reducer - 3/4-16 MORB x 7/8-14 MJIC	4
21	C53849	Manifold - Pressure Compensated Flow Control	1
22	N42880	Valve - 2 Way Ball.....	1
22A	N42881	Handle - Valve	1
23	N34443	Male Pioneer Tip - 3/4-16 FORB.....	2
24	S29960	Tag - Hose ID - Wing Lift - FOLD.....	1
25	S29961	Tag - Hose ID - Wing Lift - UNFOLD	1
26	D-4951	Nylon Tie Strap - 1/2 x 7 3/8.....	80
27	N34319	U-Bolt - 1/4 x 1 1/2 x 1 3/4 Lg	2
28	W-521	Lockwasher - 1/4.....	4
29	W-512	Hex Nut - 1/4.....	4
30	C-3918	Hex Bolt - 3/8 x 5 Lg.....	14
31	W-523	Lockwasher - 3/8.....	18
32	W-514	Hex Nut - 3/8.....	18
33	D12714	U-Bolt - 3/8 x 2 x 2 3/4 Lg	3
34	S47642	Multi-Valve Mounting Plate.....	1
35	S34428	Decal - Wings Lock	1
36	N16257	Bushing - Spacer	4
37	C14411	Oil Line Bracket.....	8
38	C-4698	Oil Line Clamp	44
39	W-538	Flatwasher - 3/8.....	20
40	M-3388	Locknut - 3/8	20
41	W-480	Hex Bolt - 3/8 x 2 1/2.....	8
42	C-1550	Hex Bolt - 3/8 x 4.....	4
43	S39565	Mounting Bracket - Valve.....	1

Wing Lift Hydraulics

51 Ft, 61 Ft and 71 Ft Models - September 2012 to Present

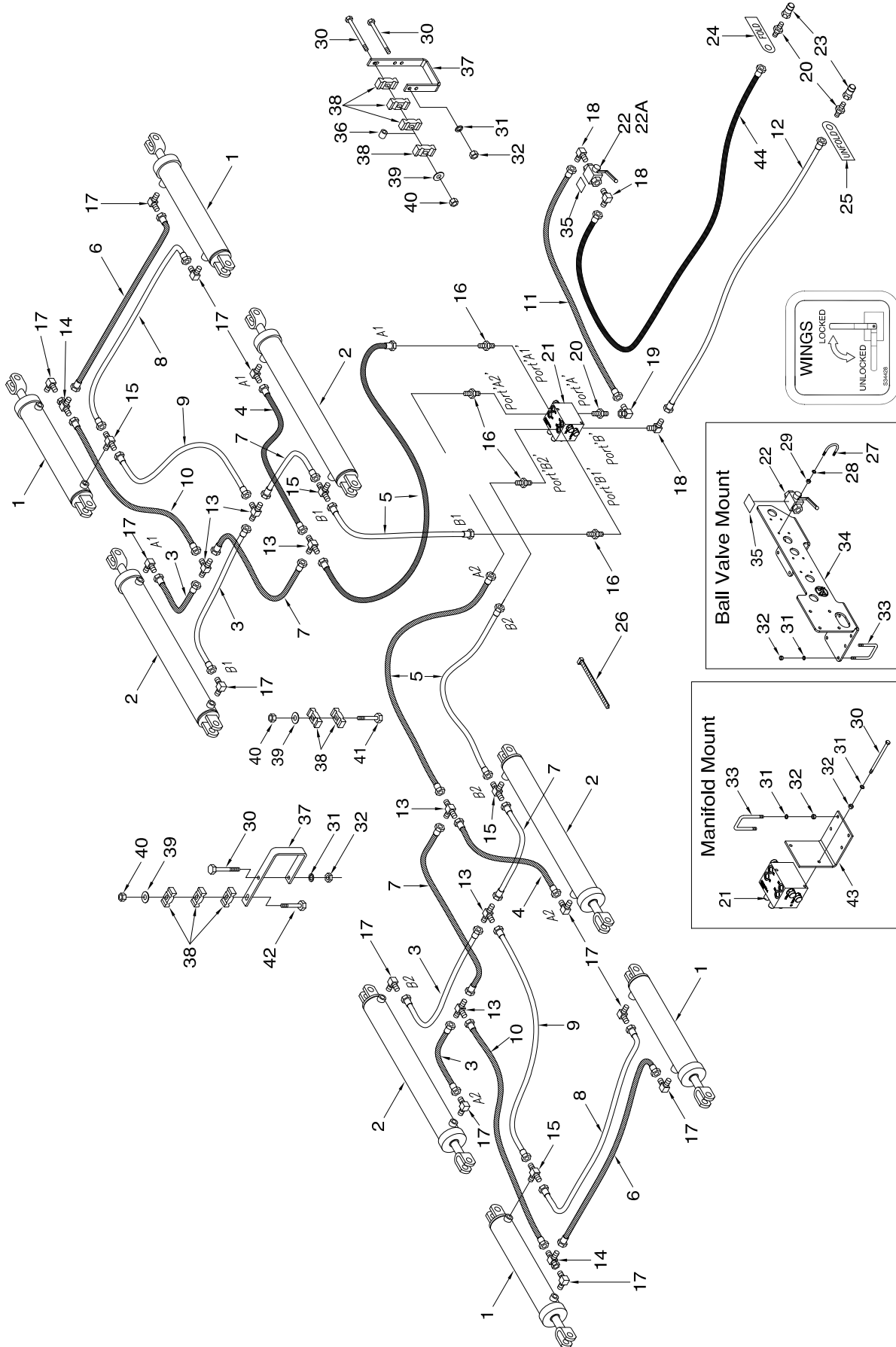

Wing Lift Hydraulics - 51 Ft, 61 Ft and 71 Ft Models - September 2012 to Present

Item	Part No.	Description	Qty
1	C26436	Cylinder - 4 x 18 - 51 ft.....	4
	C34442	Cylinder - 4 1/2 x 30 - 61 ft and 71 ft.....	4
2	C34442	Cylinder - 4 1/2 x 30 - 51 ft.....	4
	C39030	Cylinder - 4 1/2 x 36 - 61 ft.....	4
	C39490	Cylinder - 5 x 36 - 71 ft.....	4
3	C-4552	Hyd. Hose - 1/4 x 24 - 9/16-18 FJIC x 9/16-18 FJIC Ends	4
4	C14835	Hyd. Hose - 1/4 x 36 - 9/16-18 FJIC x 9/16-18 FJIC Ends	2
5	C16652	Hyd. Hose - 1/4 x 60 - 9/16-18 FJIC x 9/16-18 FJIC Ends - 61 ft & 71 ft	4
	S22406	Hyd. Hose - 1/4 x 72 - 9/16-18 FJIC x 9/16-18 FJIC Ends - 51 ft	4
6	H18267	Hyd. Hose - 1/4 x 96 - 9/16-18 FJIC x 9/16-18 FJIC Ends	2
7	W21962	Hyd. Hose - 1/4 x 108 - 9/16-18 FJIC x 9/16-18 FJIC Ends.....	4
8	S39503	Hyd. Hose - 1/4 x 132 - 9/16-18 FJIC x 9/16-18 FJIC Ends.....	2
9	D17585	Hyd. Hose - 1/4 x 176 - 9/16-18 FJIC x 9/16-18 FJIC Ends - 51 ft.....	2
	F14658	Hyd. Hose - 1/4 x 150 - 9/16-18 FJIC x 9/16-18 FJIC Ends - 61 ft.....	2
	S13317	Hyd. Hose - 1/4 x 180 - 9/16-18 FJIC x 9/16-18 FJIC Ends - 71 ft.....	2
10	D17845	Hyd. Hose - 1/4 x 198 - 9/16-18 FJIC x 9/16-18 FJIC Ends - 51 ft.....	2
	S13317	Hyd. Hose - 1/4 x 180 - 9/16-18 FJIC x 9/16-18 FJIC Ends - 61 ft.....	2
	C26347	Hyd. Hose - 1/4 x 216 - 9/16-18 FJIC x 9/16-18 FJIC Ends - 71 ft.....	2
11	C26259	Hyd. Hose - 1/2 x 108 - 7/8-14 FJIC Ends - 51 ft	1
	N19345	Hyd. Hose - 1/2 x 132 - 7/8-14 FJIC Ends - 61 ft and 71 ft	1
12	C26337	Hyd. Hose - 1/2 x 276 - 7/8-14 FJIC Ends - 51 ft	1
	S39523	Hyd. Hose - 1/2 x 420 - 7/8-14 FJIC Ends - 61 ft and 71 ft	1
13	C-4393	Tee - (3) 9/16-18 MJIC.....	6
14	C-4403	Swivel Tee - (2) 9/16-18 MJIC x (1) 9/16-18 FJIC (MMF)	2
15	N31908	Swivel Tee - (2) 9/16-18 MJIC x (1) 9/16-18 MORB.....	4
16	C15348	Male Connector - 3/4-16 MORB x 9/16-18 MJIC.....	4
17	N16143	Elbow 90 deg - 9/16-18 MJIC x 9/16-18 MORB	12
18	C24585	Elbow 90 deg - 7/8-14 MJIC x 3/4-16 MORB	3
19	K-5806	Elbow 90 deg - 7/8-14 FJIC x 7/8-14 MJIC	1
20	C14840	Reducer - 3/4-16 MORB x 7/8-14 MJIC	4
21	C53849	Manifold - Pressure Compensated Flow Control	1
22	N42880	Valve - 2 Way Ball.....	1
22A	N42881	Handle - Valve	1
23	N34443	Male Pioneer Tip - 3/4-16 FORB	2
24	S29960	Tag - Hose ID - Wing Lift - FOLD.....	1
25	S29961	Tag - Hose ID - Wing Lift - UNFOLD	1
26	D-4951	Nylon Tie Strap - 1/2 x 7 3/8.....	80
27	N34319	U-Bolt - 1/4 x 1 1/2 x 1 3/4 Lg	2
28	W-521	Lockwasher - 1/4.....	4
29	W-512	Hex Nut - 1/4	4
30	C-3918	Hex Bolt - 3/8 x 5 Lg.....	14
31	W-523	Lockwasher - 3/8.....	18
32	W-514	Hex Nut - 3/8	18
33	D12714	U-Bolt - 3/8 x 2 x 2 3/4 Lg	3
34	S47642	Multi-Valve Mounting Plate.....	1
35	S34428	Decal - Wings Lock	1
36	N16257	Bushing - Spacer	4
37	C14411	Oil Line Bracket.....	8
38	C-4698	Oil Line Clamp	44
39	W-538	Flatwasher - 3/8	20
40	M-3388	Locknut - 3/8	20
41	W-480	Hex Bolt - 3/8 x 2 1/2.....	8
42	C-1550	Hex Bolt - 3/8 x 4.....	4
43	S39565	Mounting Bracket - Valve.....	1
44	S39539	Hyd. Hose - 1/2 x 330 - 7/8-14 FJIC Ends - 51 ft.....	1
	S39523	Hyd. Hose - 1/2 x 420 - 7/8-14 FJIC Ends - 61 ft and 71 ft	1

Wing Lift Hydraulics 80 Ft and 86 Ft Models - Prior to September 2013

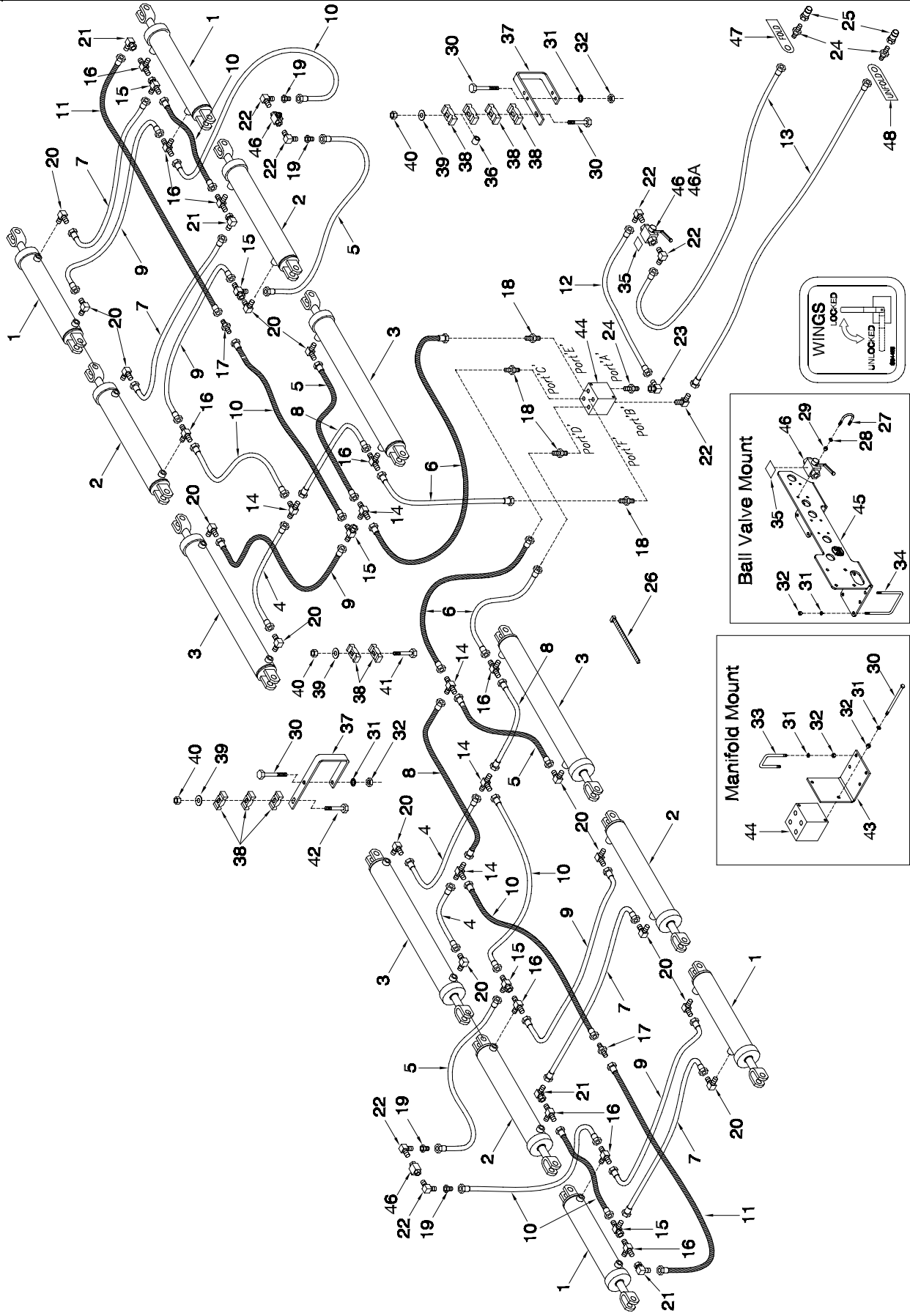

Wing Lift Hydraulics - 80 Ft and 86 Ft Models - Prior to September 2013

Item	Part No.	Description	Qty
1	C26436	Cylinder - 4 x 18	4
2	C47594	Cylinder - 5 x 30	4
3	C39490	Cylinder - 5 x 36	4
4	C-4552	Hyd. Hose - 1/4 x 24 - 9/16-18 FJIC x 9/16-18 FJIC Ends	3
5	C14835	Hyd. Hose - 1/4 x 36 - 9/16-18 FJIC x 9/16-18 FJIC Ends	4
6	H18266	Hyd. Hose - 1/4 x 80 - 9/16-18 FJIC x 9/16-18 FJIC Ends	4
7	H18267	Hyd. Hose - 1/4 x 96 - 9/16-18 FJIC x 9/16-18 FJIC Ends	4
8	W21962	Hyd. Hose - 1/4 x 108 - 9/16-18 FJIC x 9/16-18 FJIC Ends.....	3
9	S39503	Hyd. Hose - 1/4 x 132 - 9/16-18 FJIC x 9/16-18 FJIC Ends.....	5
10	S13317	Hyd. Hose - 1/4 x 180 - 9/16-18 FJIC x 9/16-18 FJIC Ends.....	8
11	C26347	Hyd. Hose - 1/4 x 216 - 9/16-18 FJIC x 9/16-18 FJIC Ends.....	2
12	N19345	Hyd. Hose - 1/2 x 132 - 7/8-14 FJIC Ends	1
13	S39523	Hyd. Hose - 1/2 x 420 - 7/8-14 FJIC Ends	2
14	C-4393	Tee - (3) 9/16-18 MJIC.....	5
15	C-4403	Swivel Tee - (2) 9/16-18 MJIC x (1) 9/16-18 FJIC.....	5
16	N31908	Swivel Tee - (2) 9/16-18 MJIC x (1) 9/16-18 MORB.....	10
17	H18269	Connector - 9/16-18 MJIC	2
18	C15348	Connector - 3/4-16 MORB x 9/16-18 MJIC	4
19	F10384	Connector - 9/16-18 MJIC x 7/8-14 FJIC	4
20	N16143	Elbow 90 deg - 9/16-18 MJIC x 9/16-18 MORB	14
21	S29967	90 Elbow - 9/16-18 FJIC x 9/16-18 MJIC	4
22	C24585	Elbow 90 deg - 7/8-14 MJIC x 3/4-16 MORB	7
23	K-5806	Elbow 90 deg - 7/8-14 FJIC x 7/8-14 MJIC	1
24	C14840	Reducer - 3/4-16 MORB x 7/8-14 MJIC	3
25	N34443	Male Pioneer Tip - 3/4-16 FORB.....	2
26	D-4951	Nylon Tie Strap - 1/2 x 7 3/8.....	80
27	N34319	U-Bolt - 1/4 x 1 1/2 x 1 3/4 Lg	2
28	W-521	Lockwasher - 1/4.....	4
29	W-512	Hex Nut - 1/4.....	4
30	C-3918	Hex Bolt - 3/8 x 5 Lg.....	14
31	W-523	Lockwasher - 3/8.....	18
32	W-514	Hex Nut - 3/8	18
33	D12714	U-Bolt - 3/8 x 2 x 2 3/4 Lg	2
34	N15098	U-Bolt - 3/8 x 4 x 5 Lg	4
35	S34428	Decal - Wings Lock	1
36	N16257	Bushing - Spacer	4
37	C14411	Oil Line Bracket.....	8
38	C-4698	Oil Line Clamp	44
39	W-538	Flatwasher - 3/8	20
40	M-3388	Locknut - 3/8	20
41	W-480	Hex Bolt - 3/8 x 2 1/2.....	8
42	C-1550	Hex Bolt - 3/8 x 4.....	4
43	S39565	Mounting Bracket - Valve.....	1
44	C53849	Manifold - Pressure Compensated Flow Control	1
45	S47642	Multi-Valve Mounting Plate.....	1
46	N42880	Valve - 2 Way Ball.....	3
46A	N42881	Handle - Valve	1
47	S29960	Tag - Hose ID - Wing Lift - FOLD.....	1
48	S29961	Tag - Hose ID - Wing Lift - UNFOLD	1

Wing Lift Hydraulics

80 Ft, 86 Ft and 90 Ft - September 2013 to Present

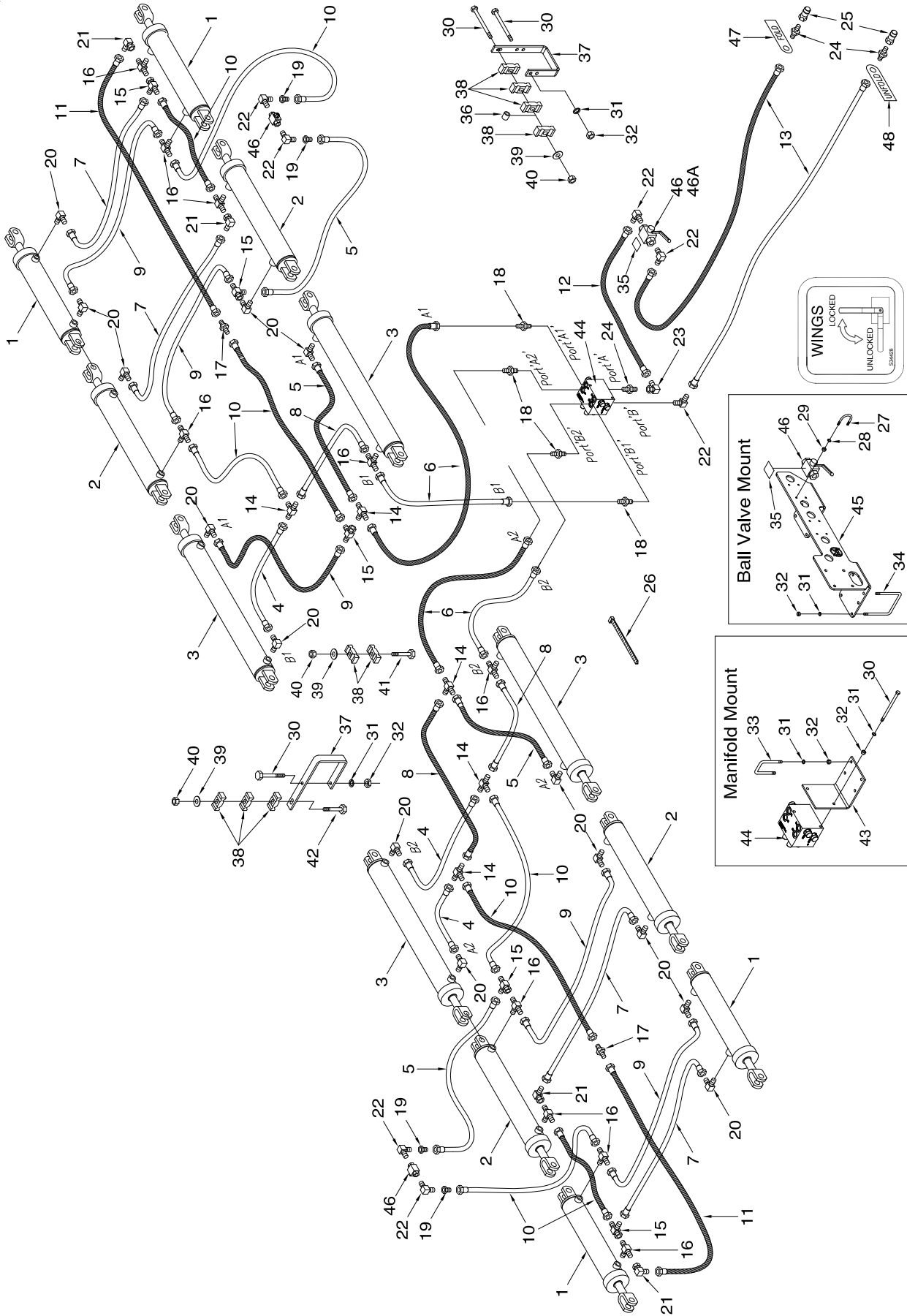

Wing Lift Hydraulics - 80 Ft, 86 Ft and 90 Ft - September 2013 to Present

Item	Part No.	Description	Qty
1	C53260	Cylinder - 4 1/2 x 18 - (Seal Kit C60599)	4
2	C53255	Cylinder - 5 1/2 x 30 - (Seal Kit C55803)	4
3	C53250	Cylinder - 5 1/2 x 36 - (Seal Kit C55803)	4
4	C-4552	Hyd. Hose - 1/4 x 24 - 9/16-18 FJIC x 9/16-18 FJIC Ends	3
5	C14835	Hyd. Hose - 1/4 x 36 - 9/16-18 FJIC x 9/16-18 FJIC Ends	4
6	H18266	Hyd. Hose - 1/4 x 80 - 9/16-18 FJIC x 9/16-18 FJIC Ends	4
7	H18267	Hyd. Hose - 1/4 x 96 - 9/16-18 FJIC x 9/16-18 FJIC Ends	4
8	W21962	Hyd. Hose - 1/4 x 108 - 9/16-18 FJIC x 9/16-18 FJIC Ends.....	3
9	S39503	Hyd. Hose - 1/4 x 132 - 9/16-18 FJIC x 9/16-18 FJIC Ends.....	5
10	S13317	Hyd. Hose - 1/4 x 180 - 9/16-18 FJIC x 9/16-18 FJIC Ends.....	8
11	C26347	Hyd. Hose - 1/4 x 216 - 9/16-18 FJIC x 9/16-18 FJIC Ends.....	2
12	N19345	Hyd. Hose - 1/2 x 132 - 7/8-14 FJIC Ends	1
13	S39523	Hyd. Hose - 1/2 x 420 - 7/8-14 FJIC Ends	2
14	C-4393	Tee - (3) 9/16-18 MJIC.....	5
15	C-4403	Swivel Tee - (2) 9/16-18 MJIC x (1) 9/16-18 FJIC (MMF)	5
16	N31908	Swivel Tee - (2) 9/16-18 MJIC x (1) 9/16-18 MORB.....	10
17	H18269	Connector - 9/16-18 MJIC	2
18	C15348	Connector - 3/4-16 MORB x 9/16-18 MJIC	4
19	F10384	Connector - 9/16-18 MJIC x 7/8-14 FJIC	4
20	N16143	Elbow 90 deg - 9/16-18 MJIC x 9/16-18 MORB	14
21	S29967	90 Elbow - 9/16-18 FJIC x 9/16-18 MJIC	4
22	C24585	Elbow 90 deg - 7/8-14 MJIC x 3/4-16 ORB	7
23	K-5806	Elbow 90 deg - 7/8-14 FJIC x 7/8-14 MJIC	1
24	C14840	Reducer - 3/4-16 MORB x 7/8-14 MJIC	3
25	N34443	Male Pioneer Tip - 3/4-16 FORB.....	2
26	D-4951	Nylon Tie Strap - 1/2 x 7 3/8.....	80
27	N34319	U-Bolt - 1/4 x 1 1/2 x 1 3/4 Lg	2
28	W-521	Lockwasher - 1/4.....	4
29	W-512	Hex Nut - 1/4.....	4
30	C-3918	Hex Bolt - 3/8 x 5 Lg.....	14
31	W-523	Lockwasher - 3/8.....	18
32	W-514	Hex Nut - 3/8	18
33	D12714	U-Bolt - 3/8 x 2 x 2 3/4 Lg	2
34	N15098	U-Bolt - 3/8 x 4 x 5 Lg	4
35	S34428	Decal - Wings Lock	1
36	N16257	Bushing - Spacer	4
37	C14411	Oil Line Bracket.....	8
38	C-4698	Oil Line Clamp	44
39	W-538	Flatwasher - 3/8	20
40	M-3388	Locknut - 3/8	20
41	W-480	Hex Bolt - 3/8 x 2 1/2.....	8
42	C-1550	Hex Bolt - 3/8 x 4.....	4
43	S39565	Mounting Bracket - Valve.....	1
44	C53849	Manifold - Pressure Compensated Flow Control	1
45	S47642	Multi-Valve Mounting Plate.....	1
46	N42880	Valve - 2 Way Ball.....	3
46A	N42881	Handle - Valve	1
47	S29960	Tag - Hose ID - Wing Lift - FOLD.....	1
48	S29961	Tag - Hose ID - Wing Lift - UNFOLD	1

Wing Lift Hydraulics Wing Valve - 80 Ft, 86 Ft and 90 Ft

**Note: Left Side Shown.
Mounts on rear cylinder on Right Side.**

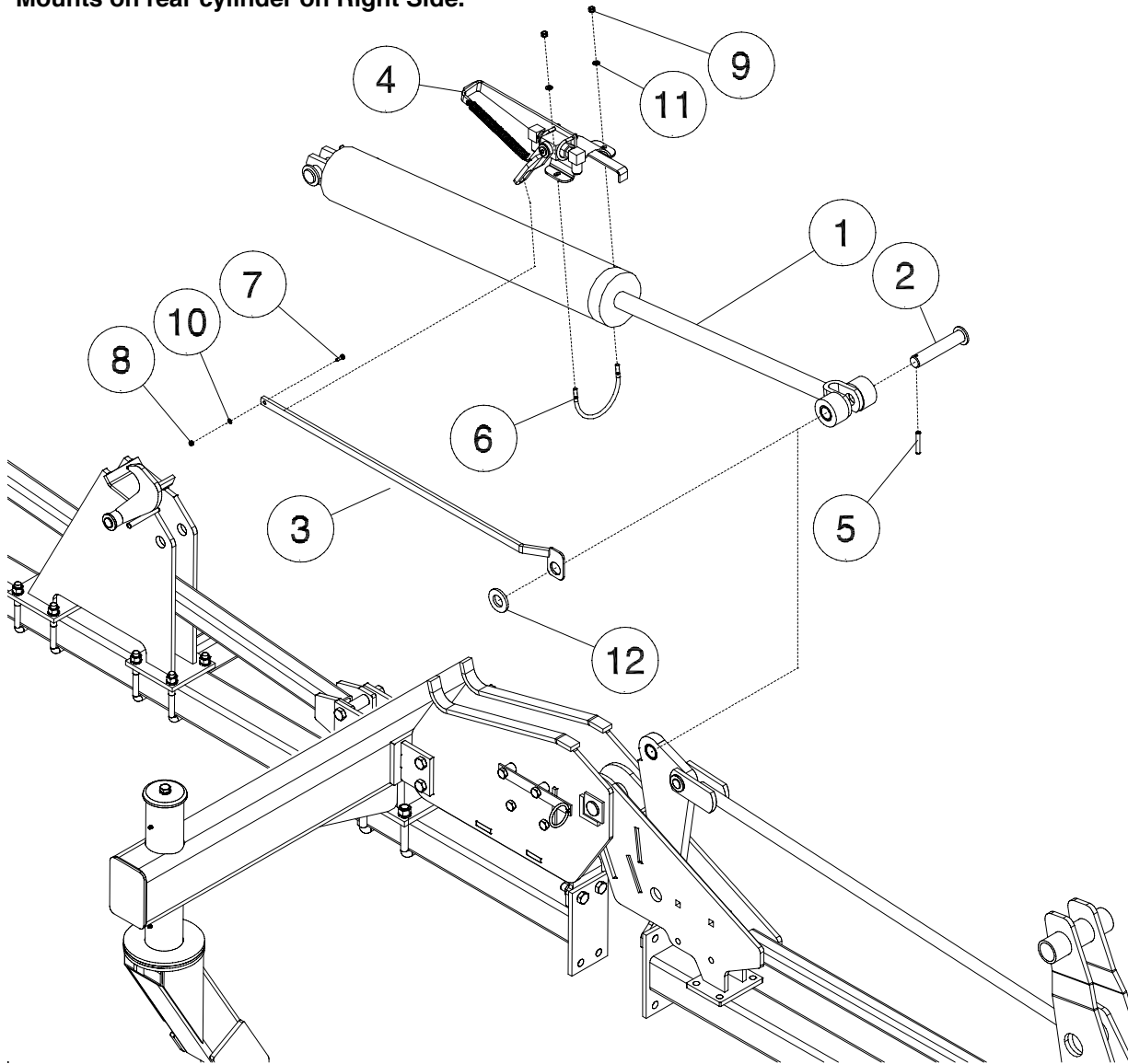

Item	Part No.	Description	Qty
1	C47594	Cylinder - 5 x 30 - Prior to September 2013	1
	C53255	Cylinder - 5 1/2 x 30 - September 2013 to present.....	1
2	S47595	Pin - 1 1/4 Dia x 6 1/2 UL.....	1
3	S47591	Valve Control Rod.....	1
4	*****	Valve Assembly - (See next page).....	1
5	D-5244	Sprial Pin - 1/4 x 2 Lg	1
6	S47597	U-Bolt - 3/8 x 5 1/2 Dia x 5 1/8 Lg - Prior to September 2013	1
	S51336	U-Bolt - 3/8 x 6 Dia x 5 1/4 Lg - September 2013 to present	1
7	W-469	Hex Head - 1/4 x 3/4 Lg	1
8	W-512	Hex Nut - 1/4	1
9	W-514	Hex Nut - 3/8.....	2
10	W-521	Lockwasher - 1/4.....	1
11	W-523	Lockwasher - 3/8.....	2
12	N13962	Washer - 1.281 ID x 2.5 OD x 1/4 Thick - Prior to September 2013.....	1
	S34182	Washer - 1.281 ID x 2.5 OD x 10 Guage Thick - September 2013 to present.....	1

Wing Lift Hydraulics Wing Valve - 80 Ft, 86 Ft and 90 Ft

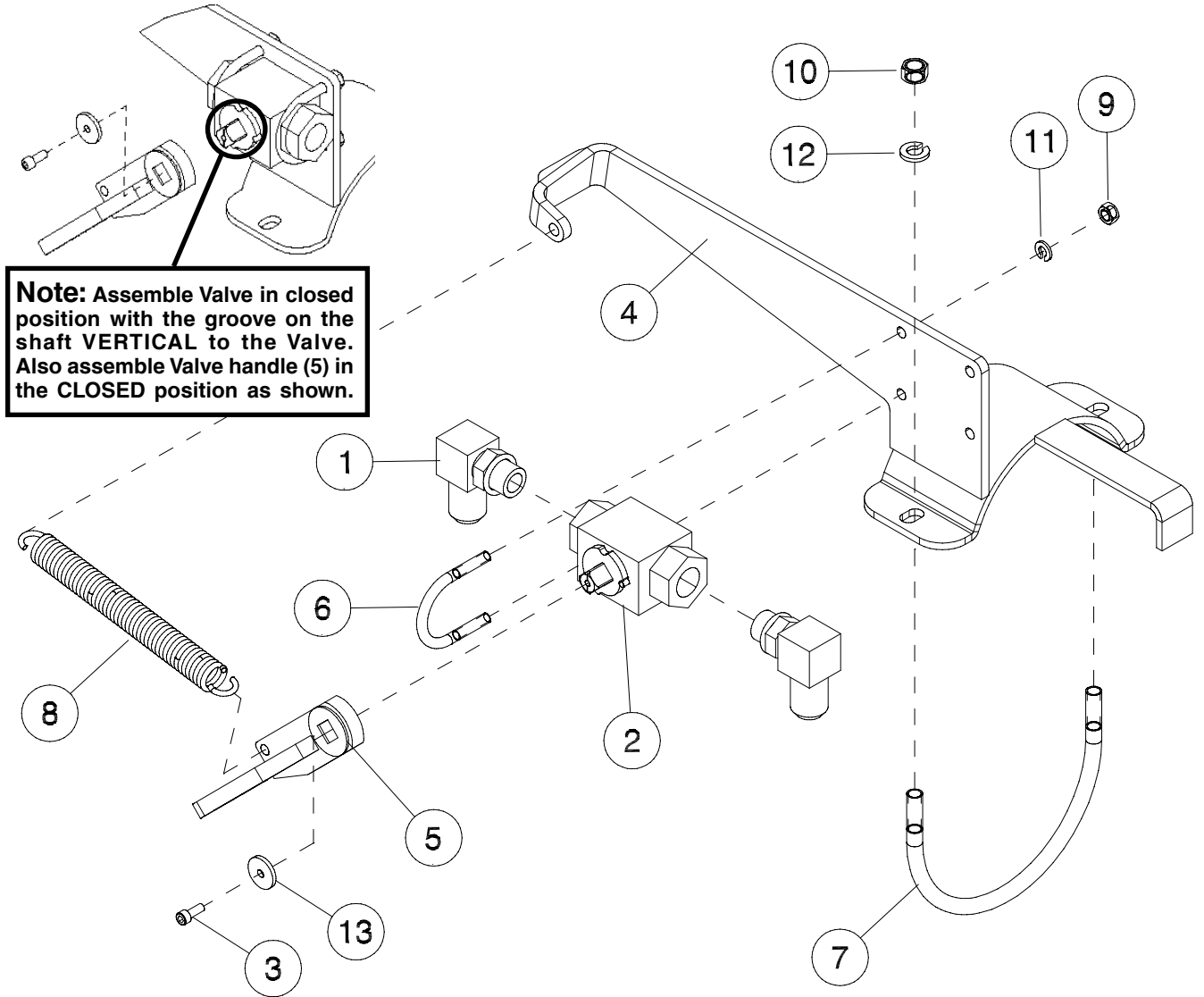

Item	Part No.	Description	Qty
1	C24585	90 Elbow - 7/8-14 MJIC x 3/4-16 MORB.....	2
2	N42880	Lock Valve.....	1
3	S39548	Socket Head Capscrew - #10 x 1/2 Lg.....	1
4	S47592	Bracket - Shut Off Valve - 5 Cylinder - Prior to September 2013.....	1
	S51335	Bracket - Shut Off Valve - 5 1/2 Cylinder - September 2013 to present.....	1
5	S39380	Handle - Valve.....	1
6	N34319	U-Bolt - 1/4 x 1 1/2 x 1 3/4 Lg.....	2
7	S47597	U-Bolt - 3/8 x 5 1/2 Dia x 5 1/8 Lg - 5 Cylinder - Prior to September 2013.....	1
	S51336	U-Bolt - 3/8 x 6 Dia x 5 1/4 Lg - 5 1/2 Cylinder - September 2013 to present.....	1
8	D-5054	Adjusting Spring.....	1
9	W-512	Hex Nut - 1/4.....	4
10	W-514	Hex Nut - 3/8.....	2
11	W-521	Lockwasher - 1/4.....	4
12	W-523	Lockwasher - 3/8.....	2
13	S39549	Washer - 3/16 ID x 13/16 OD x 12 Ga.....	1

Accumulator and Hitch Hydraulics 25 & 31 Ft - Prior to 2016

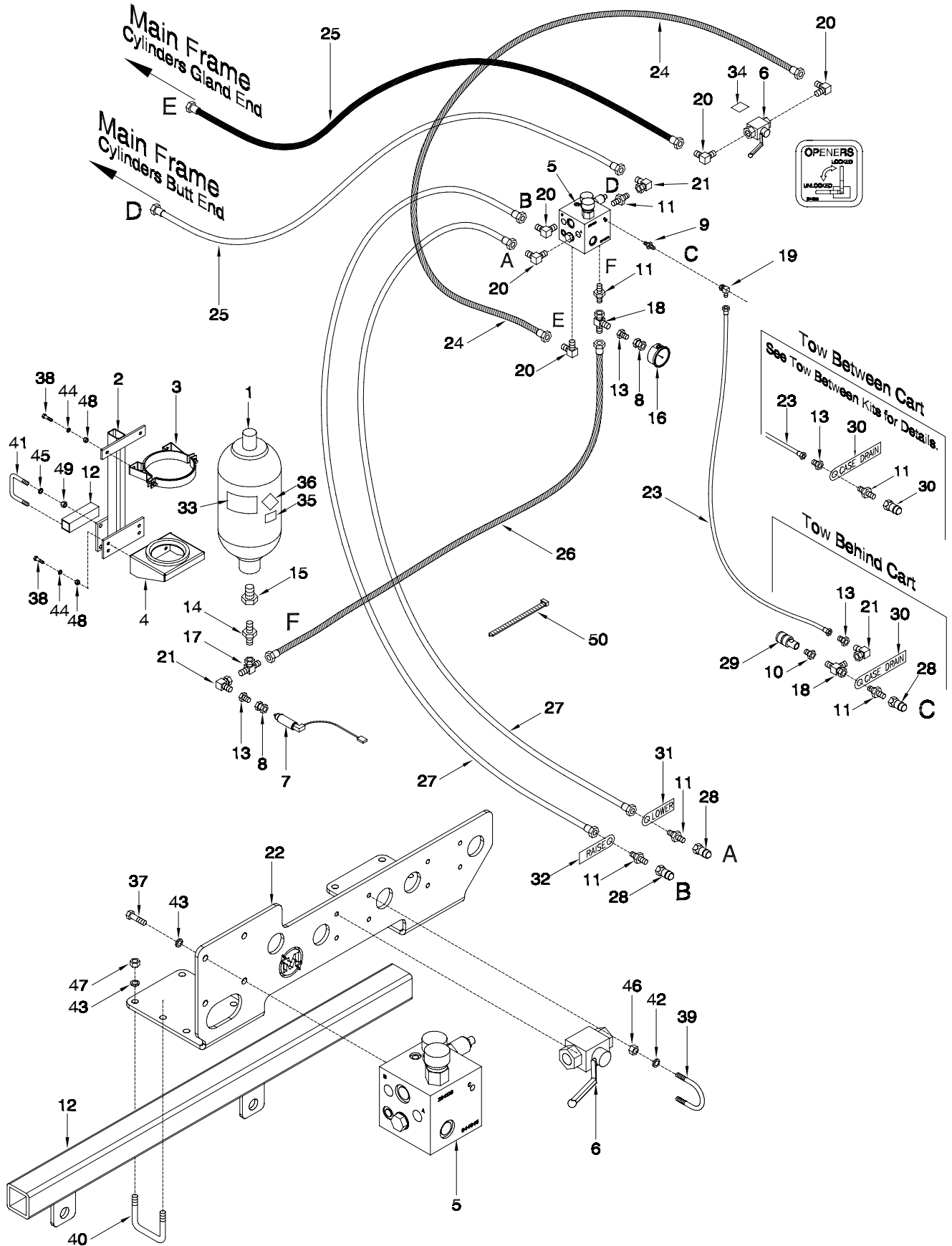

25 & 31 Ft Accumulator and Hitch Hydraulics - Prior to 2016

Item	Part No.	Description	Qty
1	S47094	2.5 Gallon Hydraulic Accumulator - Global Certified - 41 ft - 51 ft	1
2	S42320	Mounting Bracket - Accumulator	1
3	C42313	Clamp - Accumulator.....	1
4	C42314	Base - Accumulator.....	1
5	S44945	Manifold Block - Down Pressure	1
6	N42880	Valve - 2 Way Ball.....	1
6A	N42881	Handle - Valve	1
7	S49545	Pressure Transducer	1
8	S42998	Connector - 1/4 FNPT x 9/16-18 FJIC	2
9	S34115	Connector - 9/16-18 JIC x 7/16-20 MORB	1
10	N34620	Connector - Swivel - 7/8-14 MORB x 7/8-14 FJIC	1
11	C14840	Connector - 3/4-16 MORB x 7/8-14 MJIC	5
12	S45250	Tube - Accumulator Mount - 2 x 2 x 6 1/2 Lg.....	1
13	F10384	Reducer - 9/16-18 MJIC x 7/8-14 FJIC	3
14	C42312	Reducer - 7/8-14 MJIC x 1 5/16-14 MORB	1
15	C42311	Reducer - 1 7/8-14 MORB x 1 5/16-14 FORB.....	1
16	S48845	Pressure Gauge - 2 1/2 Dia with 1/4 NPT	1
17	F24559	Tee - (1) 7/8-14 FJIC x (2) 7/8-14 MJIC	1
18	H18746	Tee - Swivel - (2) 7/8-14 MJIC x (1) 7/8-14 FJIC.....	2
19	S29967	90 Elbow - 9/16-18 FJIC x 9/16-18 MJIC	1
20	C24585	90 Elbow - 7/8-14 MJIC x 3/4-16 MORB	5
21	K-5806	90 Elbow - Swivel - 7/8-14 MJIC x 7/8-14 FJIC	4
22	S47642	Multi-Valve Mounting Plate.....	1
23	C26341	Hyd Hose - 1/4 x 282 Lg w/9/16-18 FJIC.....	1
24	C-4468	Hyd Hose - 1/2 x 24 Lg w/7/8-14 FJIC x 7/8-14 FJIC	1
25	K-5685	Hyd Hose - 1/2 x 48 Lg w/7/8-14 FJIC.....	2
26	F-4565	Hyd Hose - 1/2 x 60 Lg w/7/8-14 FJIC.....	1
27	C26337	Hyd Hose - 1/2 x 276 Lg w/7/8-14 FJIC.....	2
28	N34443	Male Pioneer Tip - 3/4-16 FORB.....	3
29	N34488	Pioneer Coupler - 7/8-14 FORB.....	1
30	S44468	Tag - Hose ID - Reducing Valve - CASE DRAIN.....	1
31	S29959	Tag - Hose ID - Depth Control - LOWER.....	1
32	S29958	Tag - Hose ID - Depth Control - RAISE	1
33	C-4262	Decal - Warning - Pressure Hazard.....	1
34	S44355	Decal - Opener.....	1
35	S44930	Decal - Pre-Charged Dry Nitrogen	1
36	S44932	Decal - Compressed Nitrogen - UN1066.....	1
37	W-475	Hex Bolt - 3/8 x 1 Lg.....	4
38	W-485	Hex Bolt - 1/2 x 1 1/4 Lg.....	6
39	N34319	U-Bolt - 1/4 x 1 1/2 x 1 3/4 Lg	2
40	D12714	U-Bolt - 3/8 x 2 x 2 3/4 Lg	4
41	C-4569	U-Bolt - 5/8 x 4 5/8 x 3 1/4 Lg	2
42	W-521	Lockwasher - 1/4.....	4
43	W-523	Lockwasher - 3/8.....	12
44	W-525	Lockwasher - 1/2.....	6
45	W-526	Lockwasher - 5/8.....	4
46	W-512	Hex Nut - 1/4.....	4
47	W-514	Hex Nut - 3/8.....	12
48	W-516	Hex Nut - 1/2.....	6
49	W-517	Hex Nut - 5/8.....	4
50	S13336	Nylon Tie Strap - 28 1/4 Lg.....	12
50A	D-4838	Nylon Tie Strap - 1/2 x 14 1/2.....	8

Accumulator and Hitch Hydraulics 25 & 31 Ft - 2016 to Present

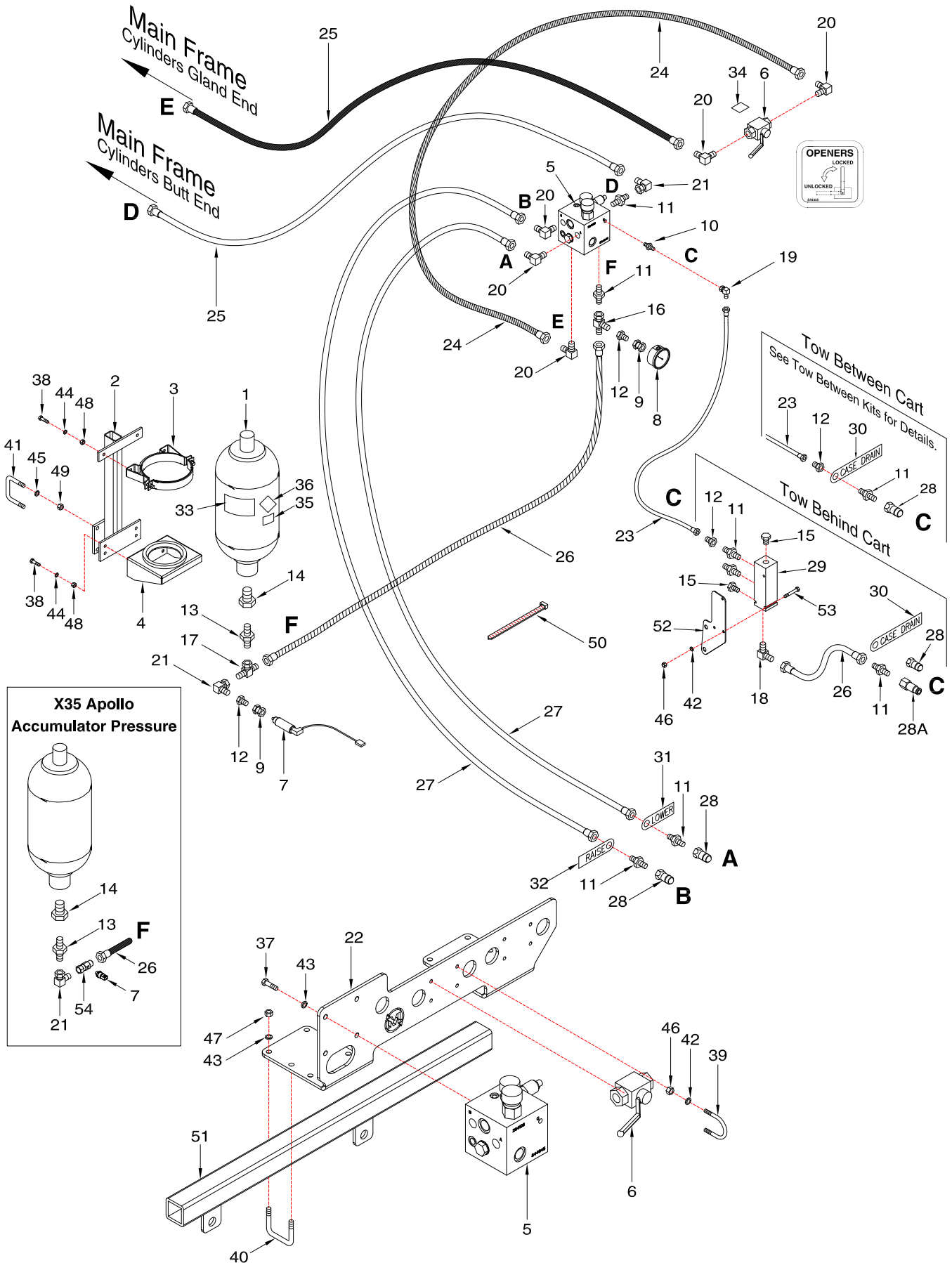

25 & 31 Ft Accumulator and Hitch Hydraulics - 2016 to Present

Item	Part No.	Description	Qty
1	S47094	2.5 Gallon Hydraulic Accumulator - Global Certified	1
2	S42320	Mounting Bracket - Accumulator	1
3	C42313	Clamp - Accumulator.....	1
4	C42314	Base - Accumulator.....	1
5	S44945	Manifold Block - Down Pressure	1
6	N42880	Valve - 2 Way Ball.....	1
6A	N42881	Handle - Valve	1
7	S49545	Pressure Transducer	1
	N58963	Pressure Transducer - Apollo System - Prior to 2018	
	K62977	Pressure Transducer - Apollo System - 2018	
8	S48845	Pressure Gauge - 2 1/2 Dia with 1/4NPT	1
9	S42998	Connector - 1/4 FNPT x 9/16-18 FJIC	2
10	S34115	Connector - 9/16-18 JIC x 7/16-20 MORB	1
11	C14840	Connector - 3/4-16 MORB x 7/8-14 MJIC	7
12	F10384	Reducer - 9/16-18 MJIC x 7/8-14 FJIC.....	3
13	C42312	Reducer - 7/8-14 MJIC x 1 5/16-14 MORB	1
14	C42311	Reducer - 1 7/8-14 MORB x 1 5/16-14 FORB.....	1
15	C28505	Plug - 3/4-16 MORB - Used on Ports not in use on Case Drain Header.....	2
16	H18746	Tee - Swivel - (2) 7/8-14 MJIC x (1) 7/8-14 FJIC	1
17	F24559	Tee - (1) 7/8-14 FJIC x (2) 7/8-14 MJIC	1
18	N34646	90 Elbow - 7/8-14 MJIC x 1 1/16-12 MORB.....	1
19	S29967	90 Elbow - 9/16-18 FJIC x 9/16-18 MJIC	1
20	C24585	90 Elbow - 7/8-14 MJIC x 3/4-16 MORB	5
21	K-5806	90 Elbow - Swivel - 7/8-14 MJIC x 7/8-14 FJIC	3
22	S47642	Multi-Valve Mounting Plate.....	1
23	F14659	Hyd Hose - 1/4 x 230 Lg w/9/16-18 FJIC - Tow Behind	1
	C26341	Hyd Hose - 1/4 x 282 Lg w/9/16-18 FJIC - Tow Between.....	1
24	C-4468	Hyd Hose - 1/2 x 24 Lg w/7/8-14 FJIC x 7/8-14 FJIC	1
25	K-5685	Hyd Hose - 1/2 x 48 Lg w/7/8-14 FJIC.....	2
26	F-4565	Hyd Hose - 1/2 x 60 Lg w/7/8-14 FJIC.....	2
27	C26337	Hyd Hose - 1/2 x 276 Lg w/7/8-14 FJIC	2
28	N34443	Male Pioneer Tip - 3/4-16 FORB.....	3
28A	K50834	3/8 Flat Face Tip - 3/4-16 FORB	1
29	N58670	Case Drain Header	1
30	S44468	Tag - Hose ID - Reducing Valve - CASE DRAIN.....	1
31	S29959	Tag - Hose ID - Depth Control - LOWER.....	1
32	S29958	Tag - Hose ID - Depth Control - RAISE	1
33	C-4262	Decal - Warning - Pressure Hazard.....	1
34	S44355	Decal - Opener.....	1
35	S44930	Decal - Pre-Charged Dry Nitrogen	1
36	S44932	Decal - Compressed Nitrogen - UN1066.....	1
37	W-475	Hex Bolt - 3/8 x 1 Lg.....	4
38	W-485	Hex Bolt - 1/2 x 1 1/4 Lg.....	6
39	N34319	U-Bolt - 1/4 x 1 1/2 x 1 3/4 Lg	2
40	D12714	U-Bolt - 3/8 x 2 x 2 3/4 Lg	4
41	C-4569	U-Bolt - 5/8 x 4 5/8 x 3 1/4 Lg	2
42	W-521	Lockwasher - 1/4	7
43	W-523	Lockwasher - 3/8.....	12
44	W-525	Lockwasher - 1/2.....	6
45	W-526	Lockwasher - 5/8.....	4
46	W-512	Hex Nut - 1/4	7
47	W-514	Hex Nut - 3/8	12
48	W-516	Hex Nut - 1/2	6
49	W-517	Hex Nut - 5/8	4
50	S13336	Nylon Tie Strap - 28 1/4 Lg.....	12
50A	D-4838	Nylon Tie Strap - 1/2 x 14 1/2.....	8
51	S45250	Tube - Accumulator Mount - 2 x 2 x 6 1/2 Lg.....	1
52	N58671	Plate - Case Drain Header Mount.....	1
53	C15319	Hex Bolt - 1/4 x 2 1/2 Lg.....	3
54	K62978	Tee - Gauge Port - 7/8-14 (#10) MJIC x 7/8-14 (#10) FJIC x 7/16-20 (#4) FORB.....	1

Accumulator and Hitch Hydraulics 41 to 86 Ft - Prior to September 2012

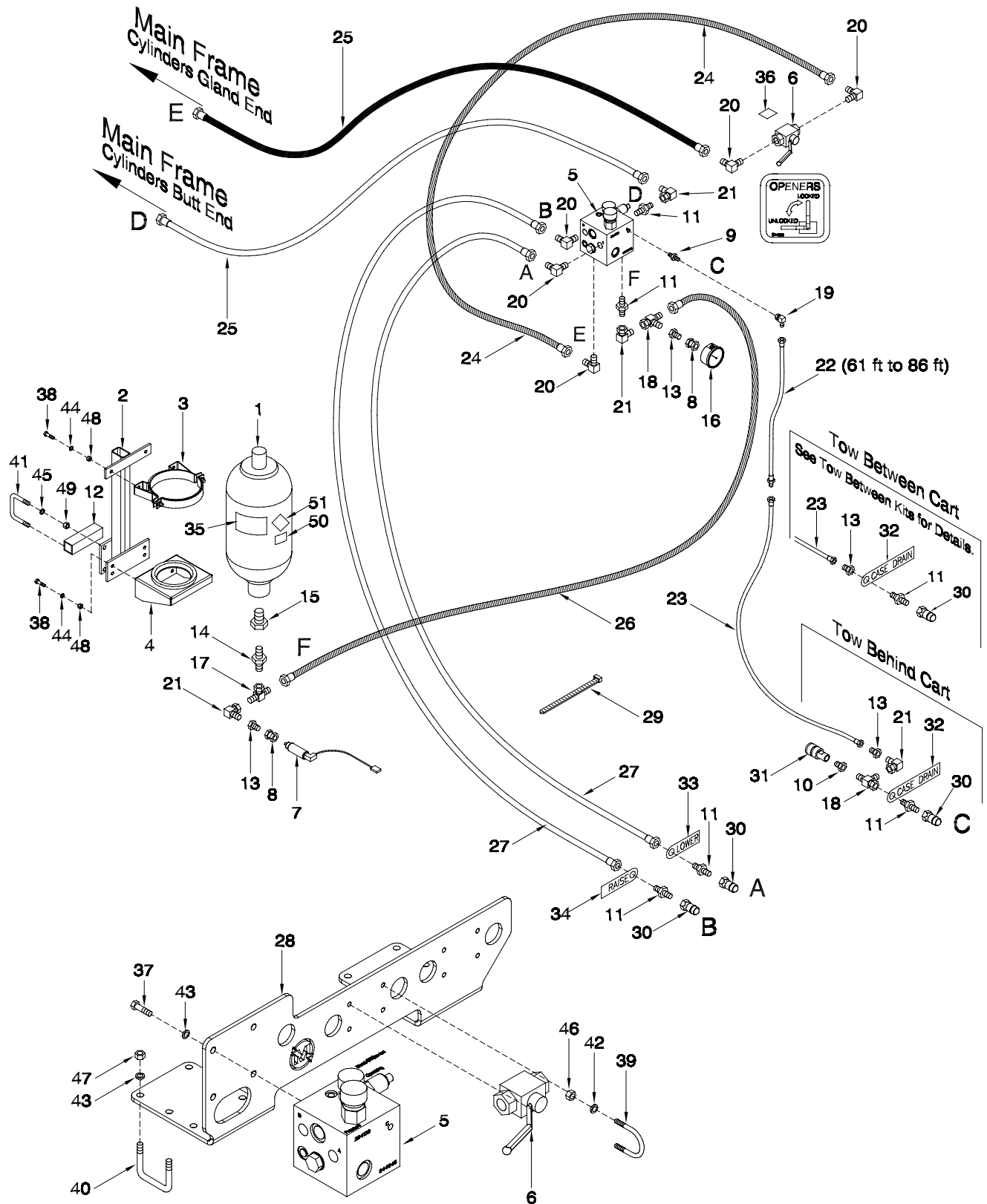

Note: Case Drain Tee with Quick Coupler must be moved to the front of a Tow Between Air Cart.

41 to 86 Ft Accumulator and Hitch Hydraulics - Prior to September

Item	Part No.	Description	Qty
1	S47094	2.5 Gallon Hydraulic Accumulator - Global Certified - 41 ft - 51 ft	1
	S47095	5 Gallon Hydraulic Accumulator - Global Certified - 61 ft - 86 ft	1
2	S42320	Mounting Bracket - Accumulator	1
3	C42313	Clamp - Accumulator	1
4	C42314	Base - Accumulator	1
5	S44945	Manifold Block - Down Pressure	1
6	N42880	Valve - 2 Way Ball	1
6A	N42881	Handle - Valve	1
7	S49545	Pressure Transducer	1
8	S42998	Connector - 1/4 FNPT x 9/16-18 FJIC	2
9	S34115	Connector - 9/16-18 JIC x 7/16-20 MORB	1
10	N34620	Connector - Swivel - 7/8-14 MORB x 7/8-14 FJIC	1
11	C14840	Connector - 3/4-16 MORB x 7/8-14 MJIC	5
12	S44929	Tube - Accumulator Mount - 2 x 2 x 6 1/2 Lg	1
13	F10384	Reducer - 9/16-18 MJIC x 7/8-14 FJIC	3
14	C42312	Reducer - 7/8-14 MJIC x 1 5/16-14 MORB	1
15	C42311	Reducer - 1 7/8-14 MORB x 1 5/16-14 FORB	1
16	S48845	Pressure Gauge - 2 1/2 Dia with 1/4NPT	1
17	F24559	Tee - (1) 7/8-14 FJIC x (2) 7/8-14 MJIC (MFM)	1
18	H18746	Tee - Swivel - (2) 7/8-14 MJIC x (1) 7/8-14 FJIC (MMF)	2
19	S29967	90 Elbow - 9/16-18 FJIC x 9/16-18 MJIC	1
20	C24585	90 Elbow - 7/8-14 MJIC x 3/4-16 MORB	5
21	K-5806	90 Elbow - Swivel - 7/8-14 MJIC x 7/8-14 FJIC	4
22	W21963	Hyd Hose - 1/4 x 96 Lg w/9/16-18 MJIC x 9/16-18 FJIC - 61 ft to 86 ft	1
23	C26341	Hyd Hose - 1/4 x 282 Lg w/9/16-18 FJIC	1
24	C-4468	Hyd Hose - 1/2 x 24 Lg w/7/8-14 FJIC x 7/8-14 FJIC	1
25	C-4404	Hyd Hose - 1/2 x 36 Lg w/7/8-14 FJIC - 41 ft to 51 ft	2
	F-4565	Hyd Hose - 1/2 x 60 Lg w/7/8-14 FJIC - 61 ft to 86 ft	2
26	F-4565	Hyd Hose - 1/2 x 60 Lg w/7/8-14 FJIC - 41 ft to 51 ft	1
	H-4410	Hyd Hose - 1/2 x 96 Lg w/7/8-14 FJIC - 61 ft to 86 ft	1
27	C26337	Hyd Hose - 1/2 x 276 Lg w/7/8-14 FJIC - 41 ft to 51 ft	2
	S39523	Hyd. Hose - 1/2 x 420 - 7/8-14 FJIC Ends - 61 ft to 86 ft	2
28	S47642	Multi-Valve Mounting Plate	1
29	S13336	Nylon Tie Strap - 28 1/4 Lg	12
29A	D-4838	Nylon Tie Strap - 1/2 x 14 1/2	8
30	N34443	Male Pioneer Tip - 3/4-16 FORB	3
31	N34488	Pioneer Coupler - 7/8-14 FORB	1
32	S44468	Tag - Hose ID - Reducing Valve - CASE DRAIN	1
33	S29959	Tag - Hose ID - Depth Control - LOWER	1
34	S29958	Tag - Hose ID - Depth Control - RAISE	1
35	C-4262	Decal - Warning - Pressure Hazard	1
36	S44355	Decal - Opener	1
37	W-475	Hex Bolt - 3/8 x 1 Lg	4
38	W-485	Hex Bolt - 1/2 x 1 1/4 Lg	6
39	N34319	U-Bolt - 1/4 x 1 1/2 x 1 3/4 Lg	2
40	D12714	U-Bolt - 3/8 x 2 x 2 3/4 Lg - 41 ft to 51 ft	4
	N15098	U-Bolt - 3/8 x 4 x 5 Lg - 61 ft to 86 ft	4
41	C-4569	U-Bolt - 5/8 x 4 5/8 x 3 1/4 Lg	2
42	W-521	Lockwasher - 1/4	4
43	W-523	Lockwasher - 3/8	12
44	W-525	Lockwasher - 1/2	6
45	W-526	Lockwasher - 5/8	4
46	W-512	Hex Nut - 1/4	4
47	W-514	Hex Nut - 3/8	12
48	W-516	Hex Nut - 1/2	6
49	W-517	Hex Nut - 5/8	4
50	S44930	Decal - Pre-Charged Dry Nitrogen	1
51	S44932	Decal - Compressed Nitrogen - UN1066	1

Accumulator and Hitch Hydraulics 41 to 90 Ft - September 2012 to 2015

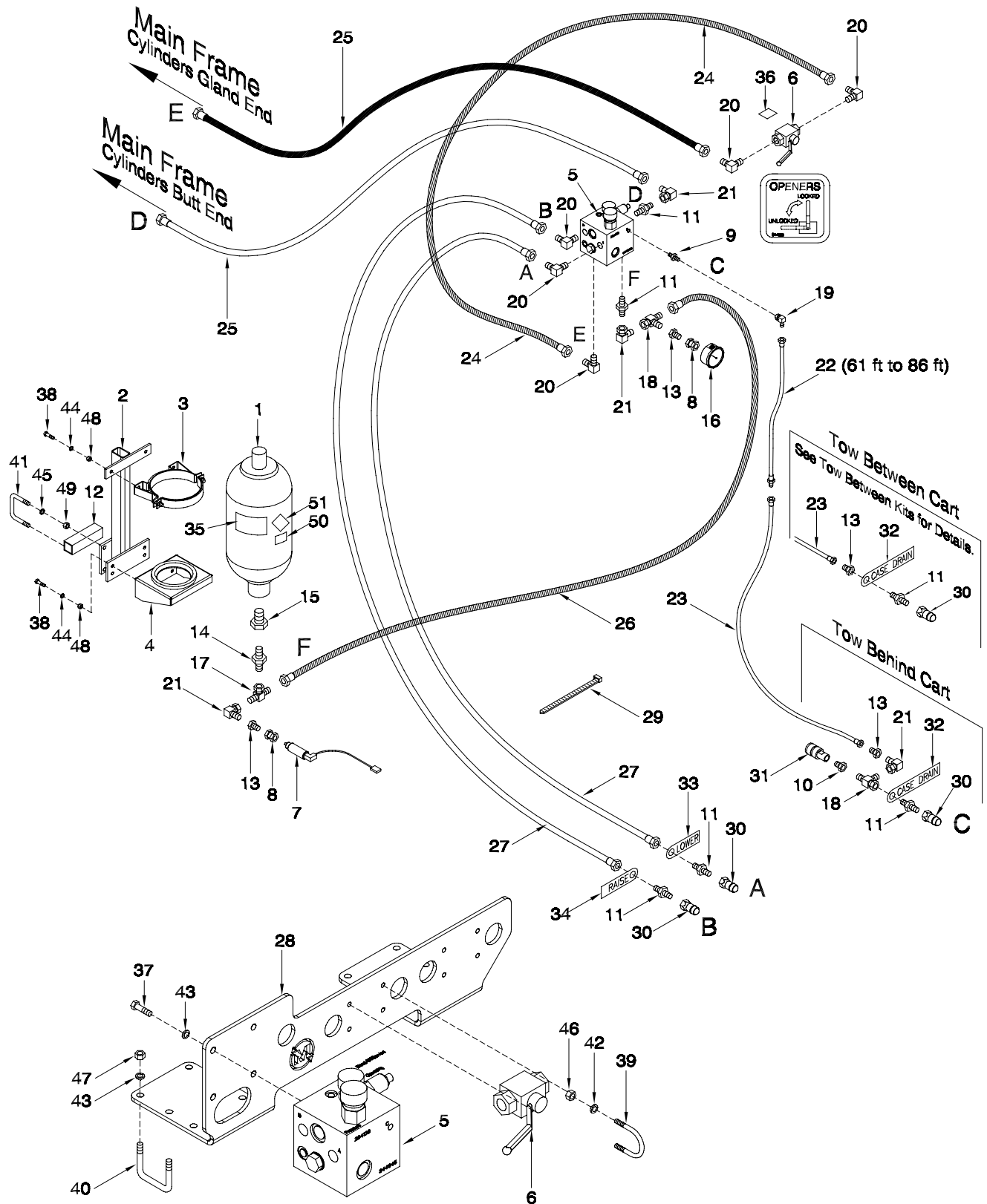

Accumulator and Hitch Hydraulics - September 2012 to 2015

Item	Part No.	Description	Qty
1	S47094	2.5 Gallon Hydraulic Accumulator - Global Certified - 41 ft - 51 ft	1
	S47095	5 Gallon Hydraulic Accumulator - Global Certified - 61 ft - 90 ft	1
2	S42320	Mounting Bracket - Accumulator	1
3	C42313	Clamp - Accumulator	1
4	C42314	Base - Accumulator	1
5	S44945	Manifold Block - Down Pressure	1
6	N42880	Valve - 2 Way Ball	1
6A	N42881	Handle - Valve	1
7	S49545	Pressure Transducer	1
8	S42998	Connector - 1/4 FNPT x 9/16-18 FJIC	2
9	S34115	Connector - 9/16-18 MJIC x 7/16-20 MORB	1
10	N34620	Connector - Swivel - 7/8-14 MORB x 7/8-14 FJIC	1
11	C14840	Connector - 3/4-16 MORB x 7/8-14 MJIC	5
12	S44929	Tube - Accumulator Mount - 2 x 2 x 6 1/2 Lg	1
13	F10384	Reducer - 9/16-18 MJIC x 7/8-14 FJIC	3
14	C42312	Reducer - 7/8-14 MJIC x 1 5/16-14 MORB	1
15	C42311	Reducer - 1 7/8-14 MORB x 1 5/16-14 FORB	1
16	S48845	Pressure Gauge - 2 1/2 Dia with 1/4NPT	1
17	F24559	Tee - (1) 7/8-14 FJIC x (2) 7/8-14 MJIC (MFM)	1
18	H18746	Tee - Swivel - (2) 7/8-14 MJIC x (1) 7/8-14 FJIC (MMF)	2
19	S29967	90 Elbow - 9/16-18 FJIC x 9/16-18 MJIC	1
20	C24585	90 Elbow - 7/8-14 MJIC x 3/4-16 MORB	5
21	K-5806	90 Elbow - Swivel - 7/8-14 MJIC x 7/8-14 FJIC	4
22	W21963	Hyd Hose - 1/4 x 96 Lg w/9/16-18 MJIC x 9/16-18 FJIC - 61 ft to 90 ft	1
23	C26341	Hyd Hose - 1/4 x 282 Lg w/9/16-18 FJIC	1
24	C-4468	Hyd Hose - 1/2 x 24 Lg w/7/8-14 FJIC x 7/8-14 FJIC	1
25	F-4565	Hyd Hose - 1/2 x 60 Lg w/7/8-14 FJIC	2
26	H-4408	Hyd Hose - 1/2 x 84 Lg w/7/8-14 FJIC - 41 ft to 51 ft	1
	H-4410	Hyd Hose - 1/2 x 96 Lg w/7/8-14 FJIC - 61 ft to 90 ft	1
27	S39539	Hyd Hose - 1/2 x 330 Lg w/7/8-14 FJIC - 41 ft to 51 ft	2
	S39523	Hyd. Hose - 1/2 x 420 - 7/8-14 FJIC Ends - 61 ft to 90 ft	2
28	S47642	Multi-Valve Mounting Plate	1
29	S13336	Nylon Tie Strap - 28 1/4 Lg	12
29A	D-4838	Nylon Tie Strap - 1/2 x 14 1/2	8
30	N34443	Male Pioneer Tip - 3/4-16 FORB	3
31	N34488	Pioneer Coupler - 7/8-14 FORB	1
32	S44468	Tag - Hose ID - Reducing Valve - CASE DRAIN	1
33	S29959	Tag - Hose ID - Depth Control - LOWER	1
34	S29958	Tag - Hose ID - Depth Control - RAISE	1
35	C-4262	Decal - Warning - Pressure Hazard	1
36	S44355	Decal - Opener	1
37	W-475	Hex Bolt - 3/8 x 1 Lg	4
38	W-485	Hex Bolt - 1/2 x 1 1/4 Lg	6
39	N34319	U-Bolt - 1/4 x 1 1/2 x 1 3/4 Lg	2
40	N15098	U-Bolt - 3/8 x 4 x 5 Lg	4
41	C-4569	U-Bolt - 5/8 x 4 5/8 x 3 1/4 Lg	2
42	W-521	Lockwasher - 1/4	4
43	W-523	Lockwasher - 3/8	12
44	W-525	Lockwasher - 1/2	6
45	W-526	Lockwasher - 5/8	4
46	W-512	Hex Nut - 1/4	4
47	W-514	Hex Nut - 3/8	12
48	W-516	Hex Nut - 1/2	6
49	W-517	Hex Nut - 5/8	4
50	S44930	Decal - Pre-Charged Dry Nitrogen	1
51	S44932	Decal - Compressed Nitrogen - UN1066	1

Accumulator and Hitch Hydraulics 41 to 90 Ft - 2016 to Present

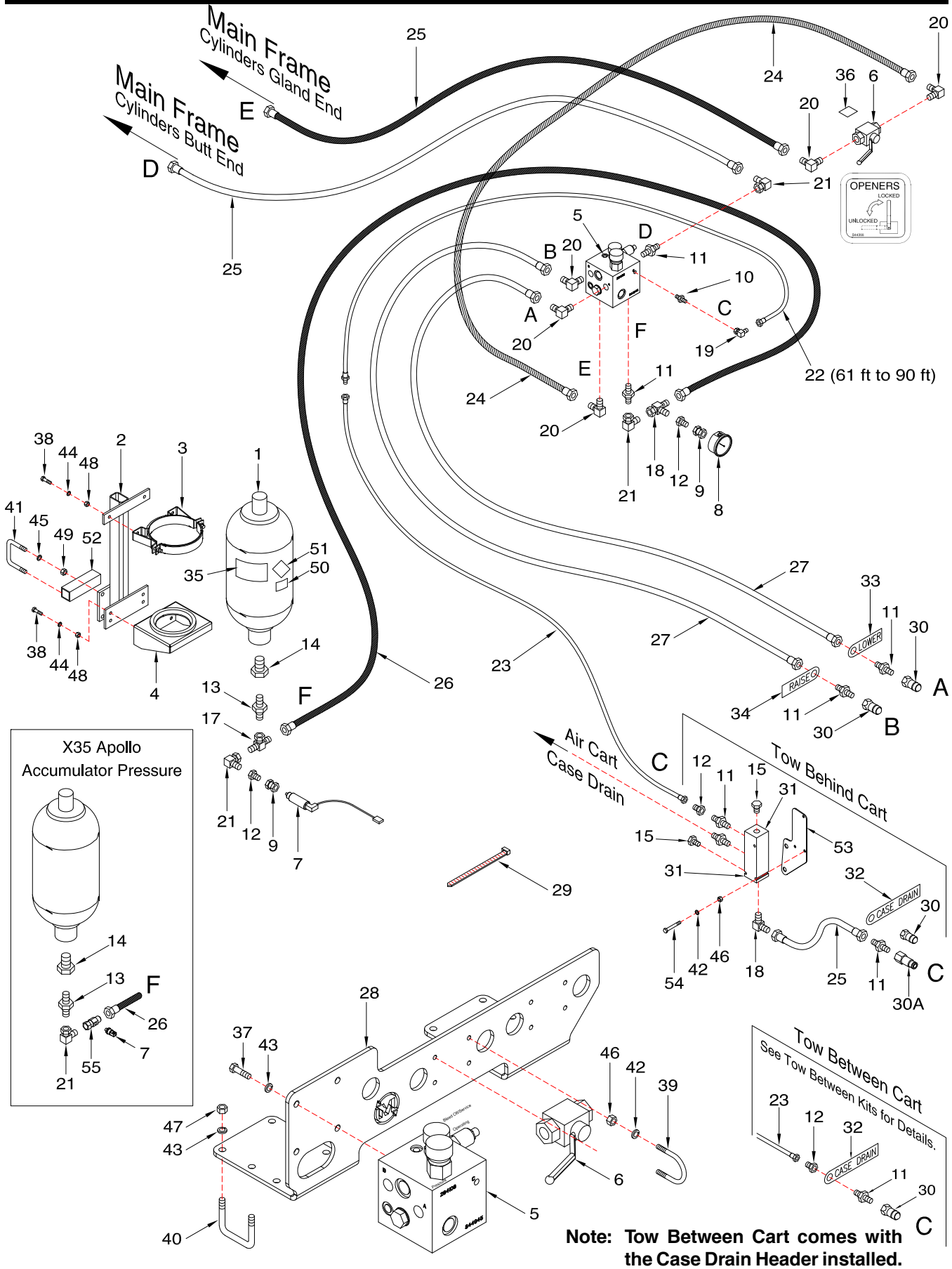

Accumulator and Hitch Hydraulics - 2016 to Present

Item	Part No.	Description	Qty
1	S47094	2.5 Gallon Hydraulic Accumulator - Global Certified - 41 ft - 51 ft	1
	S47095	5 Gallon Hydraulic Accumulator - Global Certified - 61 ft - 90 ft	1
2	S42320	Mounting Bracket - Accumulator	1
3	C42313	Clamp - Accumulator	1
4	C42314	Base - Accumulator	1
5	S44945	Manifold Block - Down Pressure	1
6	N42880	Valve - 2 Way Ball	1
6A	N42881	Handle - Valve	1
7	S49545	Pressure Transducer	1
	N58963	Pressure Transducer - Apollo System - Prior to 2018	
	K62977	Pressure Transducer - Apollo System - 2018 to present	
8	S48845	Pressure Gauge - 2 1/2 Dia with 1/4NPT	1
9	S42998	Connector - 1/4 FNPT x 9/16-18 FJIC	2
10	S34115	Connector - 9/16-18 MJIC x 7/16-20 MORB	1
11	C14840	Connector - 3/4-16 MORB x 7/8-14 MJIC	7
12	F10384	Connector - 9/16-18 MJIC x 7/8-14 FJIC	3
13	C42312	Connector - 7/8-14 MJIC x 1 5/16-14 MORB	1
14	C42311	Connector - 1 7/8-14 MORB x 1 5/16-14 FORB	1
15	C28505	Plug - 3/4-16 MORB - Used on Ports not in use on Case Drain Header	2
16	H18746	Tee - Swivel - (2) 7/8-14 MJIC x (1) 7/8-14 FJIC (MMF)	1
17	F24559	Tee - (1) 7/8-14 FJIC x (2) 7/8-14 MJIC (MFM)	1
18	N34646	90 Elbow - 7/8-14 MJIC x 1 1/16-12 MORB	1
19	S29967	90 Elbow - 9/16-18 FJIC x 9/16-18 MJIC	1
20	C24585	90 Elbow - 7/8-14 MJIC x 3/4-16 MORB	5
21	K-5806	90 Elbow - Swivel - 7/8-14 MJIC x 7/8-14 FJIC	3
22	W21963	Hyd Hose - 1/4 x 96 Lg w/9/16-18 MJIC x 9/16-18 FJIC - 61 ft to 90 ft	1
23	F14659	Hyd Hose - 1/4 x 230 Lg w/9/16-18 FJIC - Tow Behind	1
	C26341	Hyd Hose - 1/4 x 282 Lg w/9/16-18 FJIC - Tow Between	1
24	C-4468	Hyd Hose - 1/2 x 24 Lg w/7/8-14 FJIC x 7/8-14 FJIC	1
25	F-4565	Hyd Hose - 1/2 x 60 Lg w/7/8-14 FJIC	3
26	H-4408	Hyd Hose - 1/2 x 84 Lg w/7/8-14 FJIC - 41 ft to 51 ft	1
	H-4410	Hyd Hose - 1/2 x 96 Lg w/7/8-14 FJIC - 61 ft to 90 ft	1
27	S39539	Hyd Hose - 1/2 x 330 Lg w/7/8-14 FJIC - 41 ft to 51 ft	2
	S39523	Hyd. Hose - 1/2 x 420 - 7/8-14 FJIC Ends - 61 ft to 90 ft	2
28	S47642	Multi-Valve Mounting Plate	1
29	S13336	Nylon Tie Strap - 28 1/4 Lg	12
29A	D-4838	Nylon Tie Strap - 1/2 x 14 1/2	8
30	N34443	Male Pioneer Tip - 3/4-16 FORB	3
30A	K50834	3/8 Flat Face Tip - 3/4-16 FORB	1
31	N58670	Case Drain Header	1
32	S44468	Tag - Hose ID - Reducing Valve - CASE DRAIN	1
33	S29959	Tag - Hose ID - Depth Control - LOWER	1
34	S29958	Tag - Hose ID - Depth Control - RAISE	1
35	C-4262	Decal - Warning - Pressure Hazard	1
36	S44355	Decal - Opener	1
37	W-475	Hex Bolt - 3/8 x 1 Lg	4
38	W-485	Hex Bolt - 1/2 x 1 1/4 Lg	6
39	N34319	U-Bolt - 1/4 x 1 1/2 x 1 3/4 Lg	2
40	N15098	U-Bolt - 3/8 x 4 x 5 Lg	4
41	C-4569	U-Bolt - 5/8 x 4 5/8 x 3 1/4 Lg	2
42	W-521	Lockwasher - 1/4	7
43	W-523	Lockwasher - 3/8	12
44	W-525	Lockwasher - 1/2	6
45	W-526	Lockwasher - 5/8	4
46	W-512	Hex Nut - 1/4	7
47	W-514	Hex Nut - 3/8	12
48	W-516	Hex Nut - 1/2	6
49	W-517	Hex Nut - 5/8	4
50	S44930	Decal - Pre-Charged Dry Nitrogen	1
51	S44932	Decal - Compressed Nitrogen - UN1066	1
52	S44929	Tube - Accumulator Mount - 2 x 2 x 6 1/2 Lg	1
53	N58671	Plate - Case Drain Header Mount	1
54	C15319	Hex Bolt - 1/4 x 2 1/2 Lg	3
55	K62978	Tee - Gauge Port - 7/8-14 (#10) MJIC x 7/8-14 (#10) FJIC x 7/16-20 (#4) FORB	1

Accumulator and Hitch Hydraulics 41 to 90 Ft - High Speed

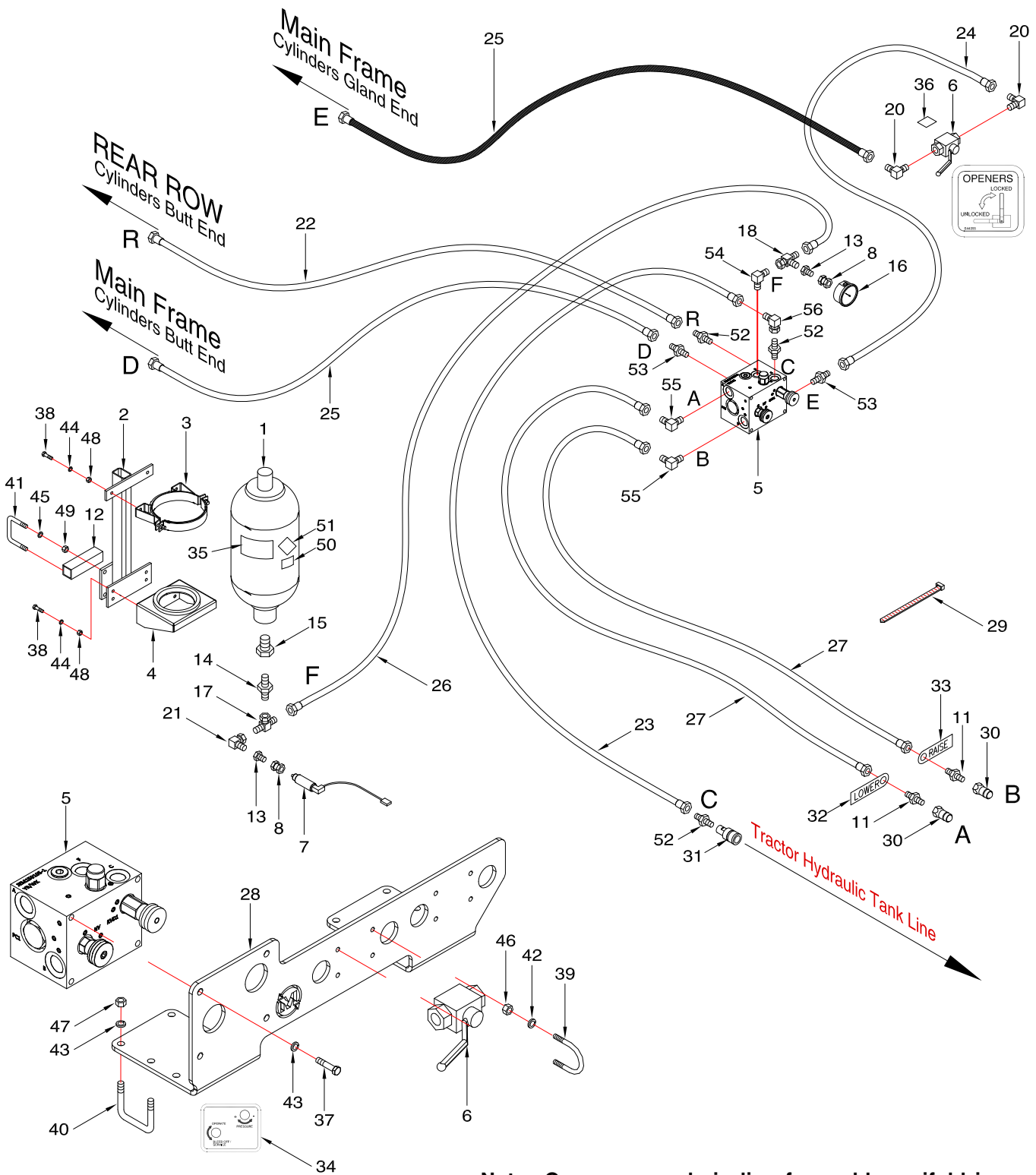

Accumulator and Hitch Hydraulics - High Speed

Item	Part No.	Description	Qty
1	S47094	2.5 Gallon Hydraulic Accumulator - Global Certified - 41 ft - 51 ft	1
	S47095	5 Gallon Hydraulic Accumulator - Global Certified - 61 ft - 86 ft	1
2	S42320	Mounting Bracket - Accumulator	1
3	C42313	Clamp - Accumulator	1
4	C42314	Base - Accumulator	1
5	S58700	Opener Valve Block - High Speed	1
6	N42880	Valve - 2 Way Ball	1
6A	N42881	Handle - Valve	1
7	S49545	Pressure Transducer	1
	K62977	Pressure Transducer - Apollo System - 2018 to present	
8	S42998	Connector - 1/4 FNPT x 9/16-18 FJIC	2
9	S34115	Connector - 9/16-18 JIC x 7/16-20 MORB	1
10	*****		
11	C14840	Connector - 3/4-16 MORB x 7/8-14 MJIC	2
12	S44929	Tube - Accumulator Mount - 2 x 2 x 6 1/2 Lg	1
13	F10384	Reducer - 9/16-18 MJIC x 7/8-14 FJIC	3
14	C42312	Reducer - 7/8-14 MJIC x 1 5/16-14 MORB	1
15	C42311	Reducer - 1 7/8-14 MORB x 1 5/16-14 FORB	1
16	S48845	Pressure Gauge - 2 1/2 Dia with 1/4 NPT	1
17	F24559	Tee - (1) 7/8-14 FJIC x (2) 7/8-14 MJIC (MFM)	1
18	H18746	Tee - Swivel - (2) 7/8-14 MJIC x (1) 7/8-14 FJIC (MMF)	1
19	S29967	90 Elbow - 9/16-18 FJIC x 9/16-18 MJIC	1
20	C24585	90 Elbow - 7/8-14 MJIC x 3/4-16 MORB	2
21	K-5806	90 Elbow - Swivel - 7/8-14 MJIC x 7/8-14 FJIC	1
22	S39504	Hyd Hose - 1/2 x 168 Lg w/7/8-14 FJIC (Port R)	1
23	S39537	Hyd Hose - 1/2 x 372 Lg w/7/8-14 FJIC (To Tractor Hydraulic Tank Line)	1
24	C-4468	Hyd Hose - 1/2 x 24 Lg w/7/8-14 FJIC x 7/8-14 FJIC	1
25	F-4565	Hyd Hose - 1/2 x 60 Lg w/7/8-14 FJIC	2
26	H-4408	Hyd Hose - 1/2 x 84 Lg w/7/8-14 FJIC - 41 ft to 51 ft	1
	H-4410	Hyd Hose - 1/2 x 96 Lg w/7/8-14 FJIC - 61 ft to 86 ft	1
27	S39539	Hyd Hose - 1/2 x 330 Lg w/7/8-14 FJIC - 41 ft to 51 ft	2
	S39523	Hyd. Hose - 1/2 x 420 Lg - 7/8-14 FJIC Ends - 61 ft to 86 ft	2
28	S62072	Multi-Valve Mounting Plate	1
29	S13336	Nylon Tie Strap - 28 1/4 Lg	12
29A	D-4838	Nylon Tie Strap - 1/2 x 14 1/2 Lg	8
30	N34443	Male Tip - 3/4-16 MORB	3
31	N34488	Pioneer Coupler - 7/8-14 FORB	1
32	S29958	Tag - Hose ID - Depth Control - RAISE	1
33	S29959	Tag - Hose ID - Depth Control - LOWER	1
34	S47334	Decal - Bleed Off/Service	1
35	C-4262	Decal - Warning - Pressure Hazard	1
36	S44355	Decal - Opener	1
37	W-475	Hex Bolt - 3/8 x 1 Lg	4
38	W-485	Hex Bolt - 1/2 x 1 1/4 Lg	6
39	N34319	U-Bolt - 1/4 x 1 1/2 x 1 3/4 Lg	2
40	N15098	U-Bolt - 3/8 x 4 x 5 Lg	4
41	C-4569	U-Bolt - 5/8 x 4 5/8 x 3 1/4 Lg	2
42	W-521	Lockwasher - 1/4	4
43	W-523	Lockwasher - 3/8	12
44	W-525	Lockwasher - 1/2	6
45	W-526	Lockwasher - 5/8	4
46	W-512	Hex Nut - 1/4	4
47	W-514	Hex Nut - 3/8	12
48	W-516	Hex Nut - 1/2	6
49	W-517	Hex Nut - 5/8	4
50	S44930	Decal - Pre-Charged Dry Nitrogen	1
51	S44932	Decal - Compressed Nitrogen - UN1066	1
52	N34505	Connector - 7/8-14 MJIC x 7/8-14 MORB	3
53	N47903	Connector - 7/8-14 MJIC x 1 1/16-12 MORB	2
54	C15318	90 Elbow - 7/8-14 MJIC x 7/8-14 MORB	1
55	N34646	90 Elbow - 7/8-14 MJIC x 1 1/16-12 MORB	2
56	K-5806	90 Elbow - 7/8-14 MJIC x 7/8-14 FJIC	1

Active Hydraulic Kit - Optional

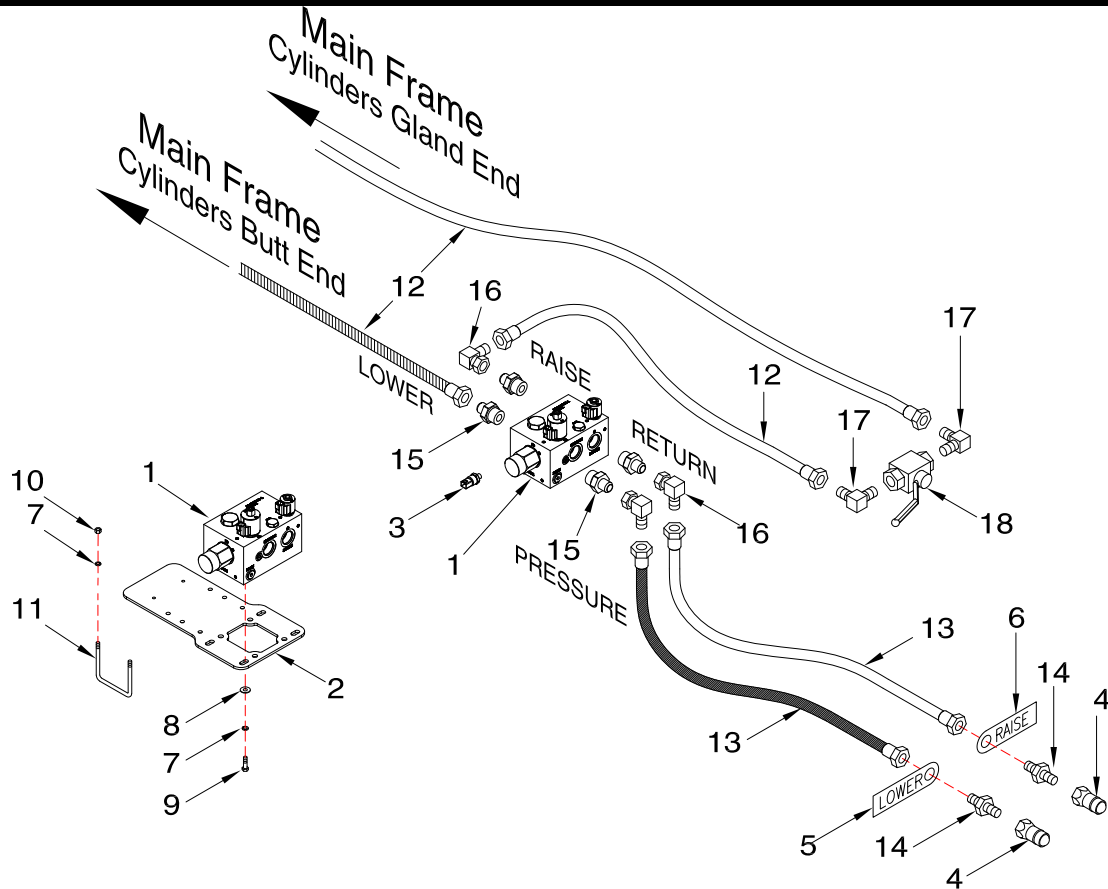

Item	Part No.	Description	Qty
1	S68006	Manifold - Opener Control - 2000 psi (Includes S2 cartridge S68007)	1
2	S68516	Valve Mounting Plate - Active Hydraulics	1
3	K62977	Pressure Transducer	1
4	N34443	Male Tip - 3/4-16 MORB	2
5	S29959	Tag - Hose ID - Depth Control - LOWER	1
6	S29958	Tag - Hose ID - Depth Control - RAISE	1
7	W-523	Lockwasher - 3/8 ... (Valve Block 4)	8
8	W-538	Flatwasher - 7/16 ID x 1 OD x 14 GA ... (Valve Block)	4
9	W-475	Hex Bolt - 3/8 x 1 Lg(Valve Block)	4
10	W-514	Nut - 3/8	4
11	N15098	U-Bolt - 3/8 x 4 3/8 x 5 Lg when mounting to a 4 x 4 Tube	2
	N19723	U-Bolt - 3/8 x 4 x 7 Lg when mounting to a 4 x 6 Tube	2
	D12714	U-Bolt - 3/8 x 2 3/8 x 3 Lg when mounting to a 2 x 2 Tube	
12	S58158	Hyd Hose - 3/4 x 60 Lg w/7/8-14 FJIC	3
13	S58157	Hyd Hose - 3/4 x 330 Lg - #10 7/8-14 FJIC Ends	2
14	C14840	Connector - 7/8-14 MJIC x 3/4-16 MORB	2
15	N47903	Connector - 7/8-14 (#10) MJIC x 1 1/16-12 (#12) MORB	4
16	K-5806	90 Elbow - 7/8-14 FJIC x 7/8-14 MJIC	3
	S68519	Active Hydraulic Kit (Includes above Items)	
		Items currently on Drill	
17	C24585	90 Elbow - 7/8-14 MJIC x 3/4-16 MORB	2
18	N42880	Lock Valve - 2 Way Ball	1
18A	N42881	Handle - Valve	1

Active Hydraulic Kit - Optional

RAZR Disc Drill, C1 and C2 Contour Air Drill Customers wanting to use Morris' Active Hydraulic System can order S68519 Active Hydraulic Kit.

In addition to this kit the customer will require one of the following options to operate and control the functions of the active hydraulic system:

- i) Customer does not have an X35 Apollo System - N65144 JEM Kit is required.
- ii) Customer has 2-3 Tank X35 Apollo System - N67052 Control Kit is required.
- iii) Customer has 4 Tank X35 Apollo System - N67051 Control Kit is required.

The Active Hydraulic Kit eliminates the accumulator and passive valve block from the system replacing it with the active valve block.

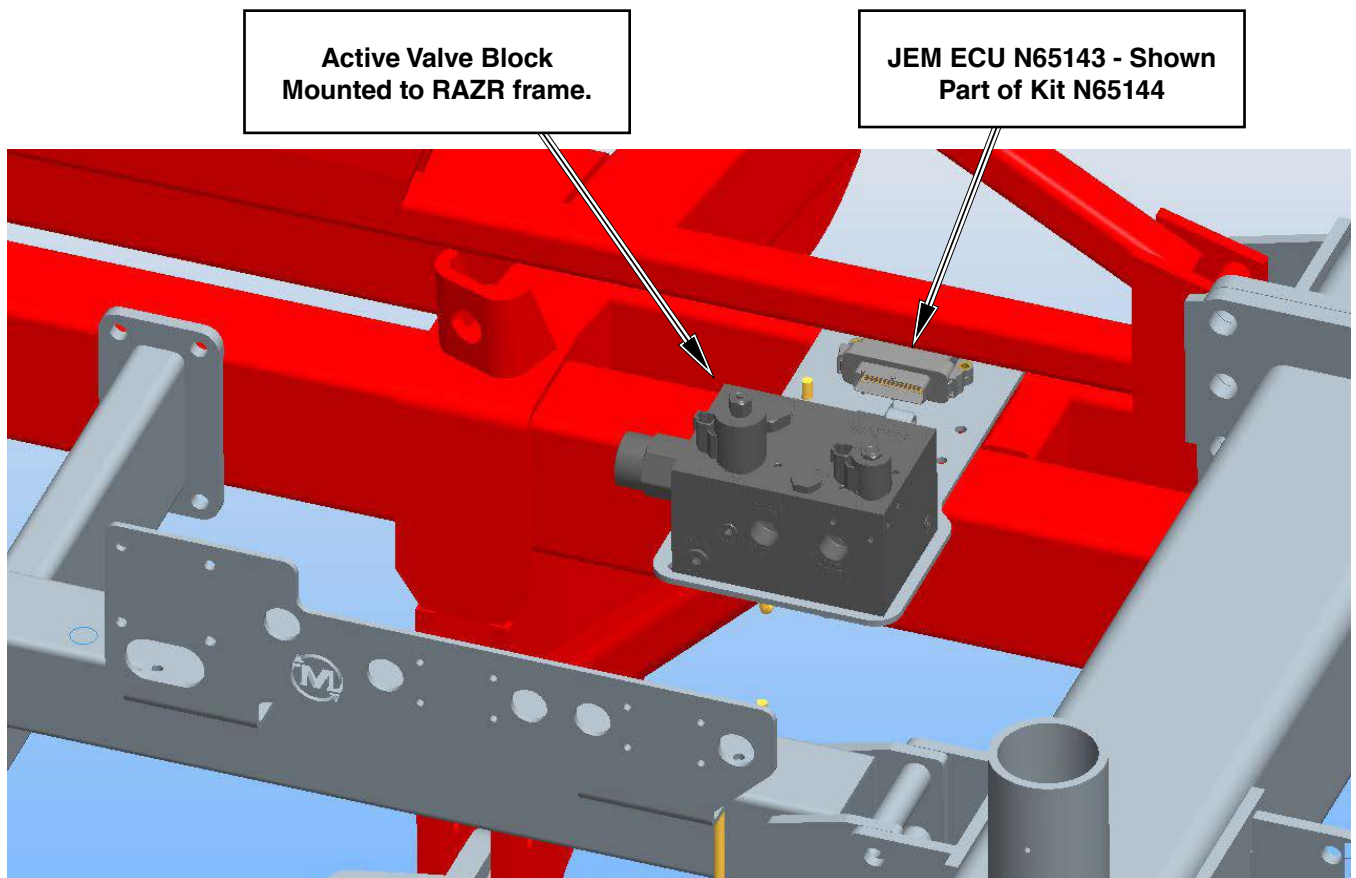

Case Drain Tow Behind Carts - 2016 to Present

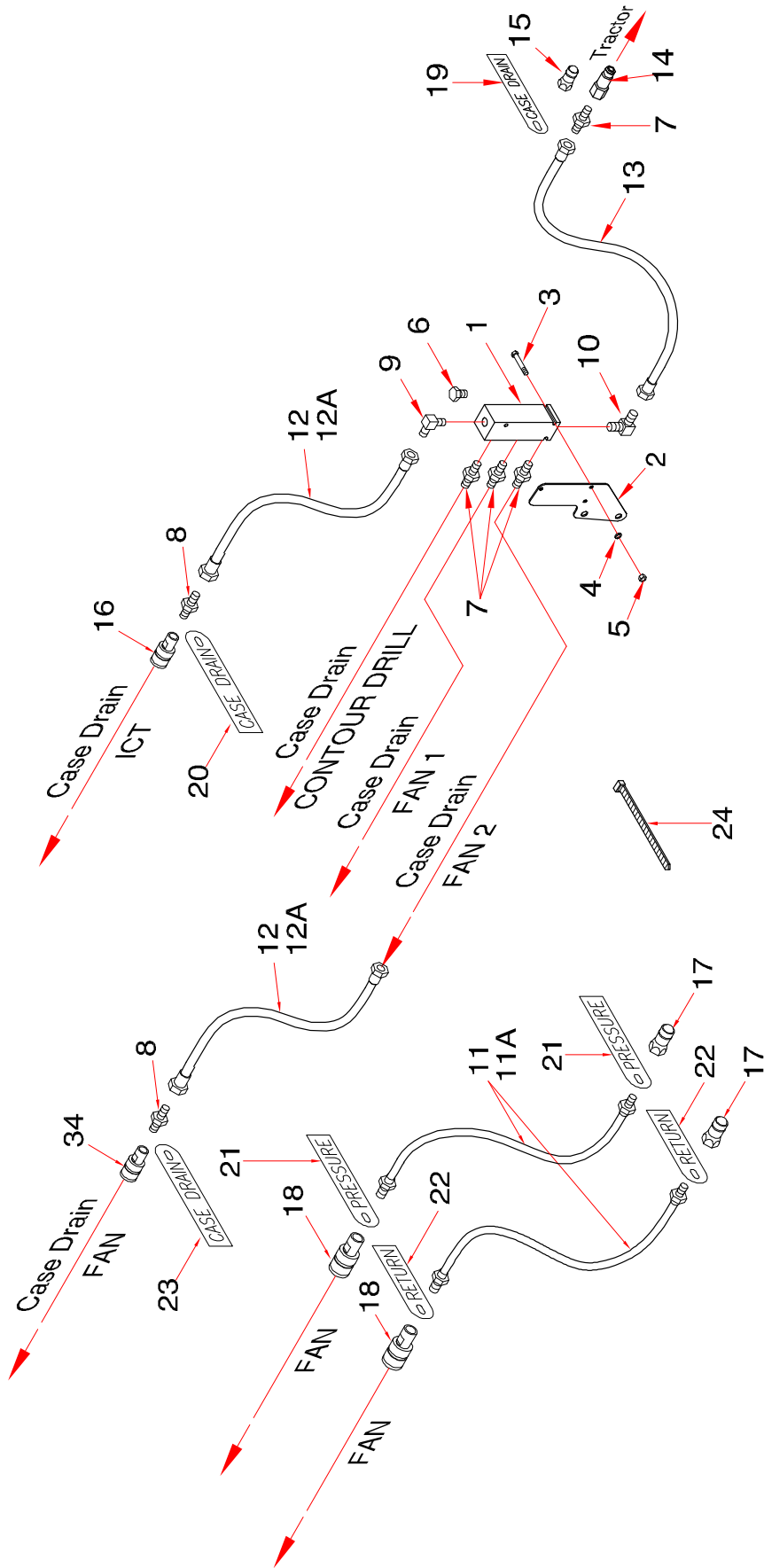

Case Drain - 2016 to Present

Item	Part No.	Description	Qty
1	N58670	Case Drain Header	1
2	N58671	Plate - Case Drain Header Mount.....	1
3	C15319	Hex Bolt - 1/4 x 2 1/2 Lg.....	3
4	W-521	Lockwasher - 1/4.....	3
5	W-512	Hex Nut - 1/4.....	3
6	C28505	Plug - 3/4-16 MORB - Used on Ports not in use on Case Drain Header.....	1
7	C14840	Connector - 3/4-16 MORB x 7/8-14 MJIC	4
8	N34505	Connector - Swivel - 7/8-14 MORB x 7/8-14 MJIC.....	1
9	C24585	90 Elbow - 7/8-14 MJIC x 3/4-16 MORB	1
10	N34646	90 Elbow - 7/8-14 MJIC x 1 1/16-12 MORB	1
11	N37036	Hyd Hose - 3/4 x 396 Lg w/1 1/16-12 MORB (3-Frame Contour Air Drill)	2
11A	N37035	Hyd Hose - 3/4 x 348 Lg w/1 1/16-12 MORB	2
11B	N44955	Hyd Hose - 3/4 x 456 Lg w/1 1/16-12 MORB (5-Frame Contour Air Drill)	2
12	N50099	Hyd Hose - 3/8 x 348 Lg w/7/8-14 FJIC x 7/8-14 FJIC Swivel End	1
12A	N55806	Hyd Hose - 3/8 x 300 Lg w/7/8-14 FJIC Ends.....	1
12B	N50088	Hyd Hose - 3/8 x 396 Lg w/7/8-14 FJIC Ends (5-Frame Contour Air Drill).....	1
13	F-4565	Hyd Hose - 1/2 x 60 Lg w/7/8-14 FJIC.....	1
14	K50834	3/8 Flat Face Tip - 3/4-16 FORB	1
15	N34443	1/2 Male Pioneer Tip - 3/4-16 FORB	2
16	N34488	1/2 Pioneer Coupler - 7/8-14 FORB.....	1
17	N37914	3/4 Male Tip - 1 1/16-12 FORB.....	2
18	N37915	3/4 Female Coupler - 1 1/16-12 FORB.....	2
19	S44468	Tag - Hose ID - Reducing Valve - CASE DRAIN.....	1
20	N58343	Tag - Hose ID - ICT - CASE DRAIN	1
21	N34576	Tag - Hose ID - Air Tank - Fan/Auger - PRESSURE	3
21A	N58340	Tag - Hose ID - Air Tank - Fan 2 - PRESSURE	3
22	N34577	Tag - Hose ID - Air Tank - Fan/Auger - RETURN	3
22A	N58341	Tag - Hose ID - Air Tank - Fan 2 - RETURN	3
23	N34578	Tag - Hose ID - Air Tank - Fan/Auger - CASE DRAIN	3
23A	N58342	Tag - Hose ID - Air Tank - Fan 2 - CASE DRAIN	3
24	D-4951	Nylon Tie Strap - 7 3/8 Lg	12

Opener Hydraulics

10 inch Spacing - 25 & 31 Ft Model - Prior to 2020

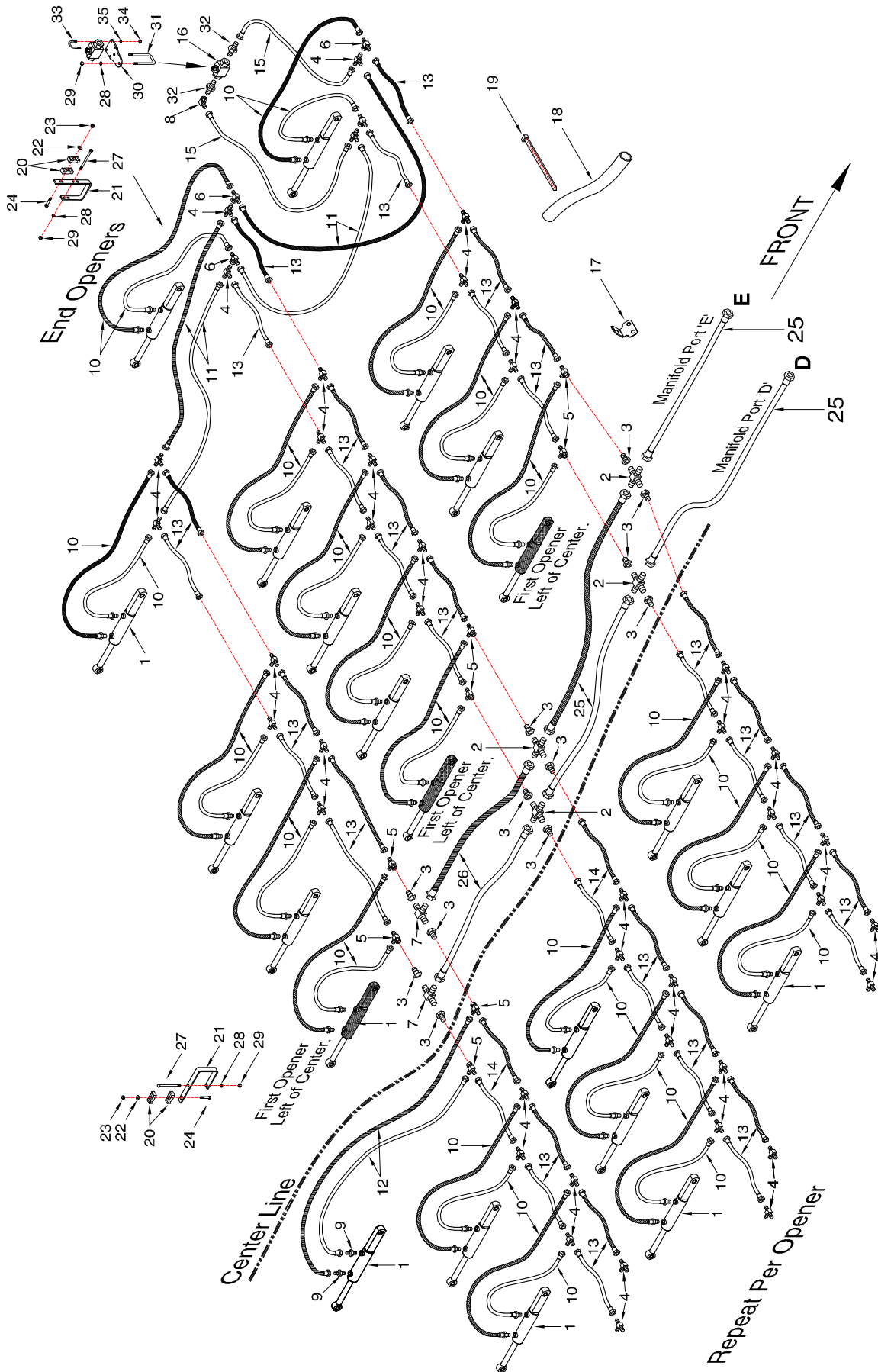

Opener Hydraulics - 10 inch Spacing - 25 & 31 Ft Model - Prior to 2020

Item	Part No.	Description	Qty
1	*****	Cylinder - See Opener Section for details.....	AsReq
2	C-4401	Cross - (4) 7/8-14 MJIC.....	4
3	F10384	Reducer - 7/8-14 MJIC x 9/16-18 MJIC.....	12
4	C-4393	Tee - (3) 9/16-18 MJIC.....	64
5	C-4403	Tee - (2) 9/16-18 MJIC x (1) 9/16-18 FJIC.....	8
6	C14901	Tee - (2) 9/16-18 MJIC x (1) 9/16-18 FJIC.....	8
7	C-4394	Tee - (3) 7/8-14 MJIC	2
8	S29967	90 Elbow - 9/16-18 FJIC x 9/16-18 MJIC	2
9	N29358	Connector - 9/16-18 MJIC x 9/16-18 MORB.....	2
10	S44352	Hyd Hose - 1/4 x 24 Lg w/ #6 9/16-18 FJIC x #6 9/16-18 MORB	68
11	C16652	Hyd Hose - 1/4 x 60 Lg w/9/16-18 FJIC.....	8
12	S22406	Hyd Hose - 1/4 x 72 Lg w/ #6 9/16-18 FJIC.....	2
13	S42967	Hyd Hose - 3/8 x 30 Lg w/ #6 9/16-18 FJIC.....	60
14	S42969	Hyd Hose - 3/8 x 36 Lg w/ #6 9/16-18 FJIC.....	4
15	C-4552	Hyd Hose - 1/4 x 24Lg w/ #6 9/16-18 FJIC.....	4
16	N42880	Lock Valve	2
17	S47976	Hose Holder - Prior to 2020	AsReq
	S72070	Hose Holder - Quantum Opener - 2020 to Present	
18	R480045	Hose Cover - 2 ID x 8 Lg (Bulk/foot)	AsReq
19	D-4951	Nylon Tie Strap - 1/2 x 7 3/8.....	AsReq
20	C-4698	Oil Line Clamp	12
21	C14411	Oil Line Bracket.....	6
22	W-538	Flatwasher - 3/8	6
23	M-3388	Lock Nut - 3/8.....	6
24	W-480	Hex Bolt - 3/8 x 2 1/2.....	6
25	K-5685	Hyd Hose - 1/2 x 48 Lg w/7/8-14 FJIC.....	4
26	F-4565	Hyd Hose - 1/2 x 60 Lg w/7/8-14 FJIC.....	2
27	C-3918	Hex Bolt - 3/8 x 5 Lg.....	6
28	W-523	Lockwasher - 3/8.....	10
29	W-514	Hex Nut - 3/8	10
30	S39546	Mount Plate - Ball Valve	2
31	N15097	U-Bolt - 3/8 x 2 3/8 x 5 Lg	2
32	C15348	Connector - 9/16-18 MJIC x 3/4-16 MORB	4
33	N34319	U-Bolt - 1/4 x 1 1/2 x 2	4
34	W-512	Hex Nut - 1/4.....	8
35	W-521	Lockwasher - 1/4.....	8

Opener Hydraulics

10 inch Spacing - 25 & 31 Ft Model - 2020 to Present

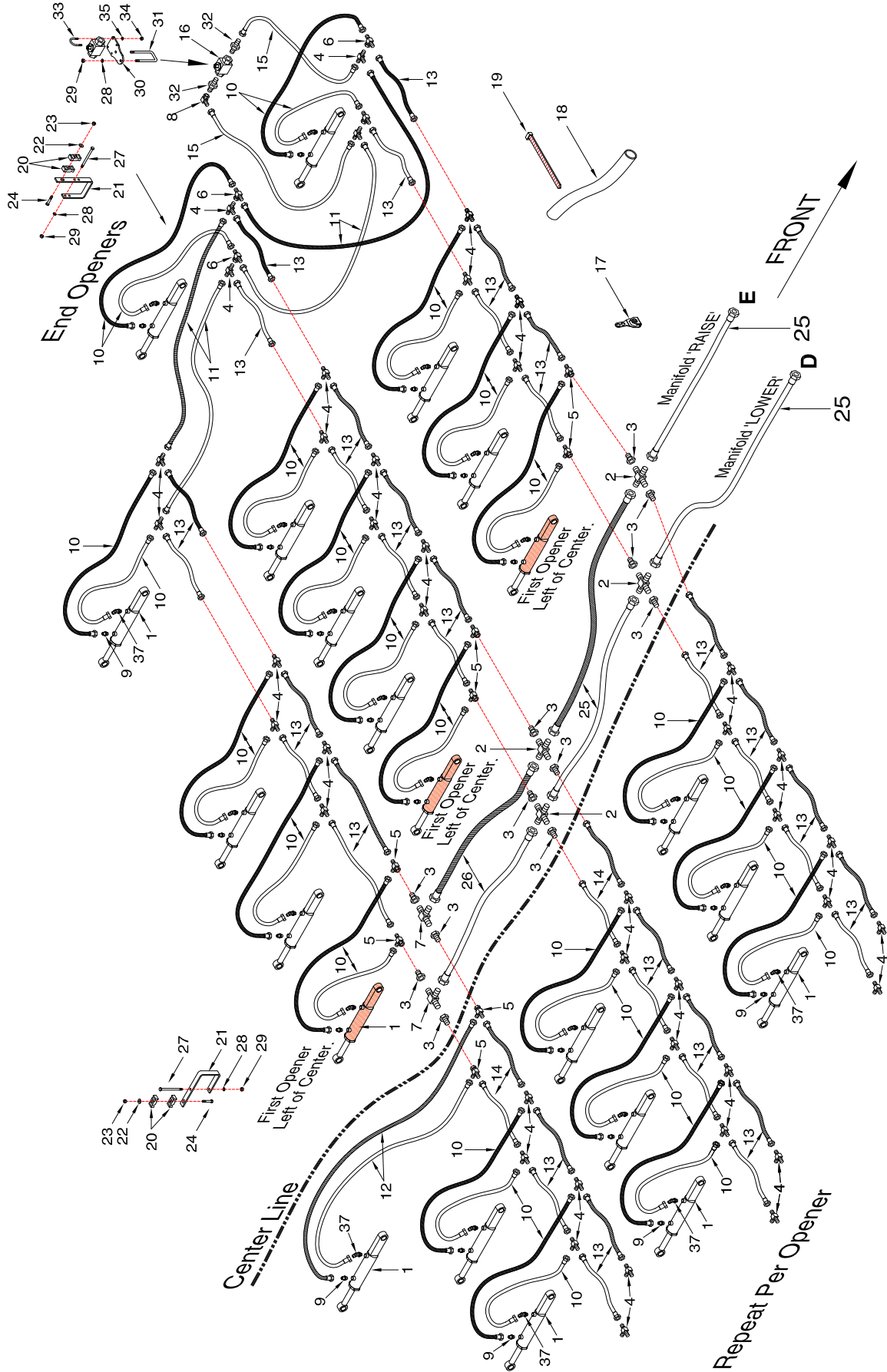

Opener Hydraulics - 10 inch Spacing - 25 & 31 Ft Model - 2020 to Present

Item	Part No.	Description	Qty
1	*****	Cylinder - 1 3/4 Bore x 4 Stroke	AsReq
2	C-4401	Cross - (4) 7/8-14 MJIC.....	4
3	F10384	Reducer - 7/8-14 MJIC x 9/16-18 MJIC.....	12
4	C-4393	Tee - (3) 9/16-18 MJIC.....	64
5	C-4403	Tee - (2) 9/16-18 MJIC x (1) 9/16-18 FJIC.....	8
6	C14901	Tee - (2) 9/16-18 MJIC x (1) 9/16-18 FJIC.....	8
7	C-4394	Tee - (3) 7/8-14 MJIC	2
8	S29967	90 Elbow - 9/16-18 FJIC x 9/16-18 MJIC	2
9	N29358	Connector - 9/16-18 (#06) MJIC x 9/16-18 (#06) MORB.....	AsReq
10	S66243	Hyd Hose - 1/4 x 22 Lg - #6 9/16-18 FJIC Ends (High Flex)	AsReq
11	C16652	Hyd Hose - 1/4 x 60 Lg w/9/16-18 FJIC.....	8
12	S22406	Hyd Hose - 1/4 x 72 Lg w/ #6 9/16-18 FJIC.....	2
13	S42967	Hyd Hose - 3/8 x 30 Lg w/ #6 9/16-18 FJIC.....	60
14	S42969	Hyd Hose - 3/8 x 36 Lg w/ #6 9/16-18 FJIC.....	4
15	C-4552	Hyd Hose - 1/4 x 24Lg w/ #6 9/16-18 FJIC.....	4
16	N42880	Lock Valve	2
17	S72070	Hose Holder - Opener - Low Profile.....	AsReq
18	R480045	Hose Cover - 2 ID x 8 Lg (Bulk/foot)	AsReq
19	D-4951	Nylon Tie Strap - 1/2 x 7 3/8.....	AsReq
20	C-4698	Oil Line Clamp	12
21	C14411	Oil Line Bracket.....	6
22	W-538	Flatwasher - 3/8.....	6
23	M-3388	Lock Nut - 3/8.....	6
24	W-480	Hex Bolt - 3/8 x 2 1/2.....	6
25	K-5685	Hyd Hose - 1/2 x 48 Lg w/7/8-14 FJIC.....	4
26	F-4565	Hyd Hose - 1/2 x 60 Lg w/7/8-14 FJIC.....	2
27	C-3918	Hex Bolt - 3/8 x 5 Lg.....	6
28	W-523	Lockwasher - 3/8.....	10
29	W-514	Hex Nut - 3/8.....	10
30	S39546	Mount Plate - Ball Valve	2
31	N15097	U-Bolt - 3/8 x 2 3/8 x 5 Lg	2
32	C15348	Connector - 9/16-18 MJIC x 3/4-16 MORB	4
33	N34319	U-Bolt - 1/4 x 1 1/2 x 2	4
34	W-512	Hex Nut - 1/4.....	8
35	W-521	Lockwasher - 1/4.....	8
37	N19578	45 Elbow - 9/16-18 (#06) MJIC x 9/16-18 (#06) MORB	AsReq

Opener Hydraulics 10 inch Spacing - 41 Ft to 71 Ft

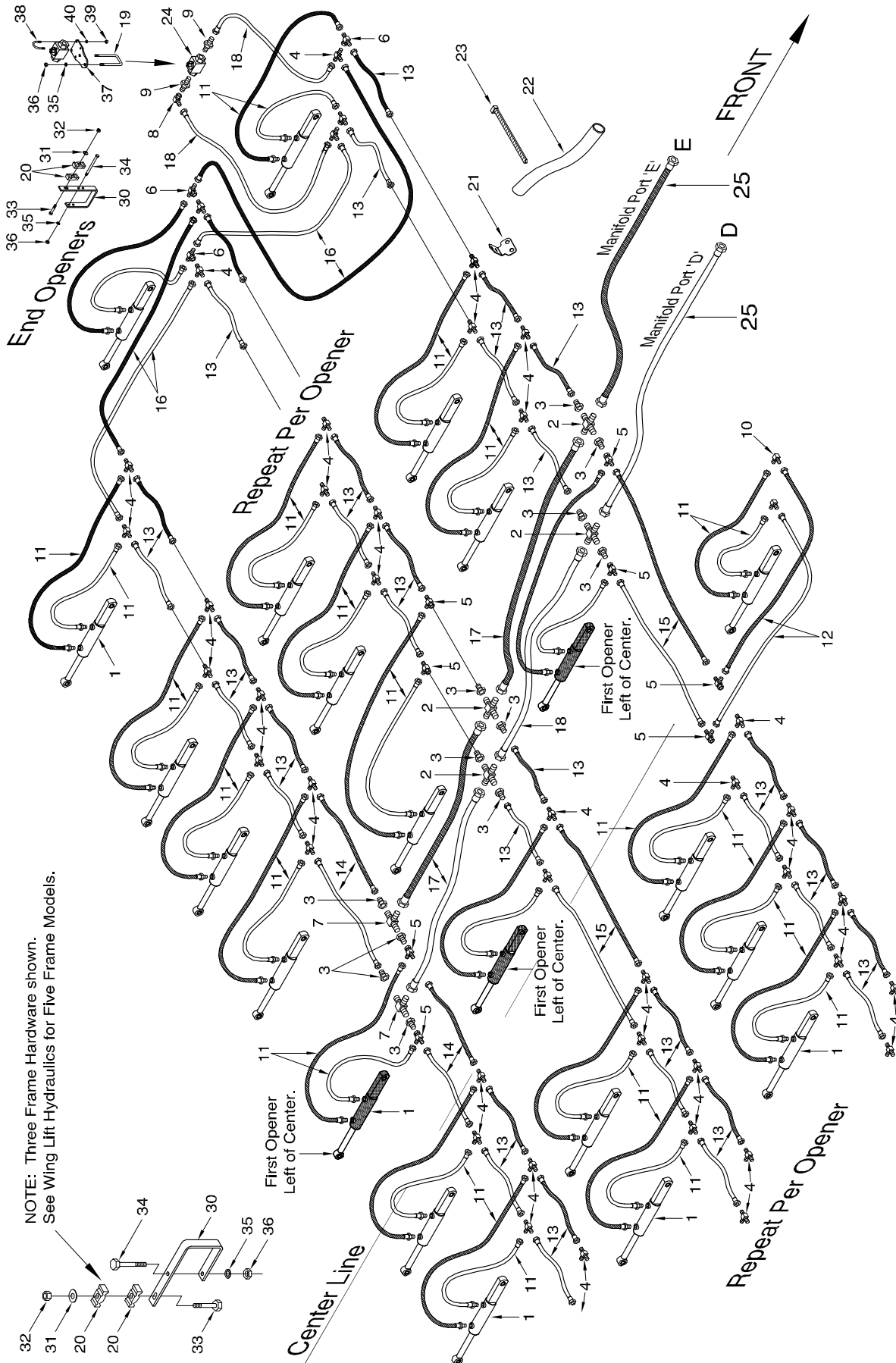

NOTE: Three Frame Hardware shown.
See Wing Lift Hydraulics for Five Frame Models.

Opener Hydraulics - 10 inch Spacing - 41 Ft to 71 Ft

Item	Part No.	Description	Qty
1	*****	Cylinder - See Opener Section for details.....	AsReq
2	C-4401	Cross - (4) 7/8-14 MJIC.....	4
3	F10384	Reducer - 7/8-14 MJIC x 9/16-18 MJIC.....	12
4	C-4393	Tee - (3) 9/16-18 MJIC.....	AsReq
5	C-4403	Tee - (2) 9/16-18 MJIC x (1) 9/16-18 FJIC (MMF).....	12
6	C14901	Tee - (2) 9/16-18 MJIC x (1) 9/16-18 FJIC (MFM).....	8
7	C-4394	Tee - (3) 7/8-14 MJIC.....	2
8	S29967	90 Elbow - 9/16-18 FJIC x 9/16-18 MJIC.....	2
9	C15348	Connector - 9/16-18 MJIC x 3/4-16 MORB.....	4
10	F-3867	90 Elbow - 9/16-18 MJIC.....	2
11	S44352	Hyd Hose - 1/4 x 24 Lg w/ #6 9/16-18 FJIC x #6 9/16-18 MORB.....	AsReq
12	H18267	Hyd Hose - 1/4 x 96 Lg w/9/16-18 FJIC.....	2
13	S42967	Hyd Hose - 3/8 x 30 Lg w/ #6 9/16-18 FJIC.....	AsReq
14	S42969	Hyd Hose - 3/8 x 36 Lg w/ #6 9/16-18 FJIC	4
15	S44353	Hyd Hose - 3/8 x 48 Lg w/ #6 9/16-18 FJIC	4
16	C16652	Hyd Hose - 1/4 x 60 Lg w/9/16-18 FJIC.....	8
17	K-5685	Hyd Hose - 1/2 x 48 Lg w/7/8-14 FJIC.....	4
18	C-4552	Hyd Hose - 1/4 x 24Lg w/ #6 9/16-18 FJIC.....	4
19	N15097	U-Bolt - 3/8 x 2 3/8 x 5 Lg.....	2
20	C-4698	Oil Line Clamp.....	12
21	S47976	Hose Holder - Prior to 2020.....	AsReq
	S72070	Hose Holder - Quantum Opener - 2020 to Present.....	
22	R480045	Hose Cover 2 ID Bulk/foot.....	AsReq
23	D-4951	Nylon Tie Strap - 1/2 x 7 3/8.....	AsReq
24	N42880	Lock Valve.....	2
25	F-4565	Hyd Hose - 1/2 x 60 Lg w/7/8-14 FJIC.....	2
26	S44313	Hose Holder - 61 ft and 71 ft.....	6
26A	S47749	Hose Holder - 51 ft.....	4
27	C-4569	U-Bolt - 5/8 x 4 x 3 1/4 Lg - 51 ft to 71 ft.....	2
28	W-526	Lockwasher - 5/8.....	4
29	W-517	Hex Nut - 5/8.....	4
30	C14411	Oil Line Bracket.....	6
31	W-538	Flatwasher - 3/8.....	6
32	M-3388	Locknut - 3/8.....	6
33	W-480	Hex Bolt - 3/8 x 2 1/2.....	6
34	C-3918	Hex Bolt - 3/8 x 5 Lg.....	6
35	W-523	Lockwasher - 3/8.....	10
36	W-514	Hex Nut - 3/8.....	10
37	S39546	Mount Plate - Ball Valve.....	2
38	N34319	U-Bolt - 1/4 x 1 1/2 x 2.....	4
39	W-512	Hex Nut - 1/4.....	8
40	W-521	Lockwasher - 1/4.....	8

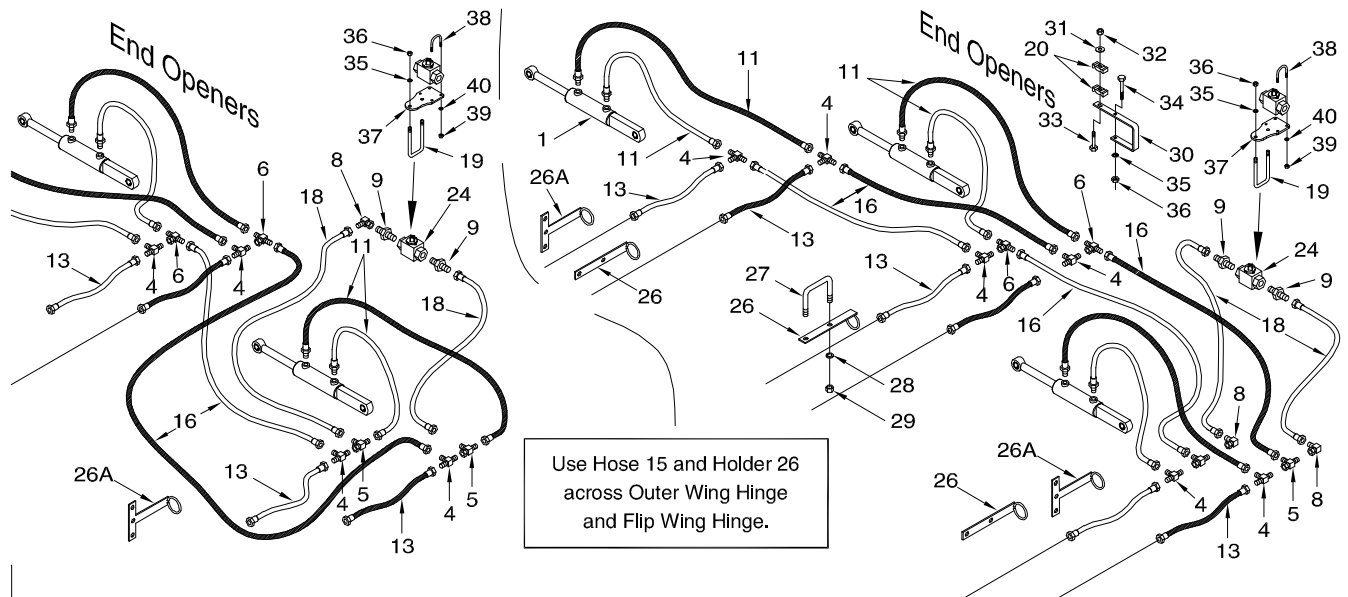

Opener Hydraulics

12 inch Spacing - 25 & 31 Ft Model - Prior to 2020

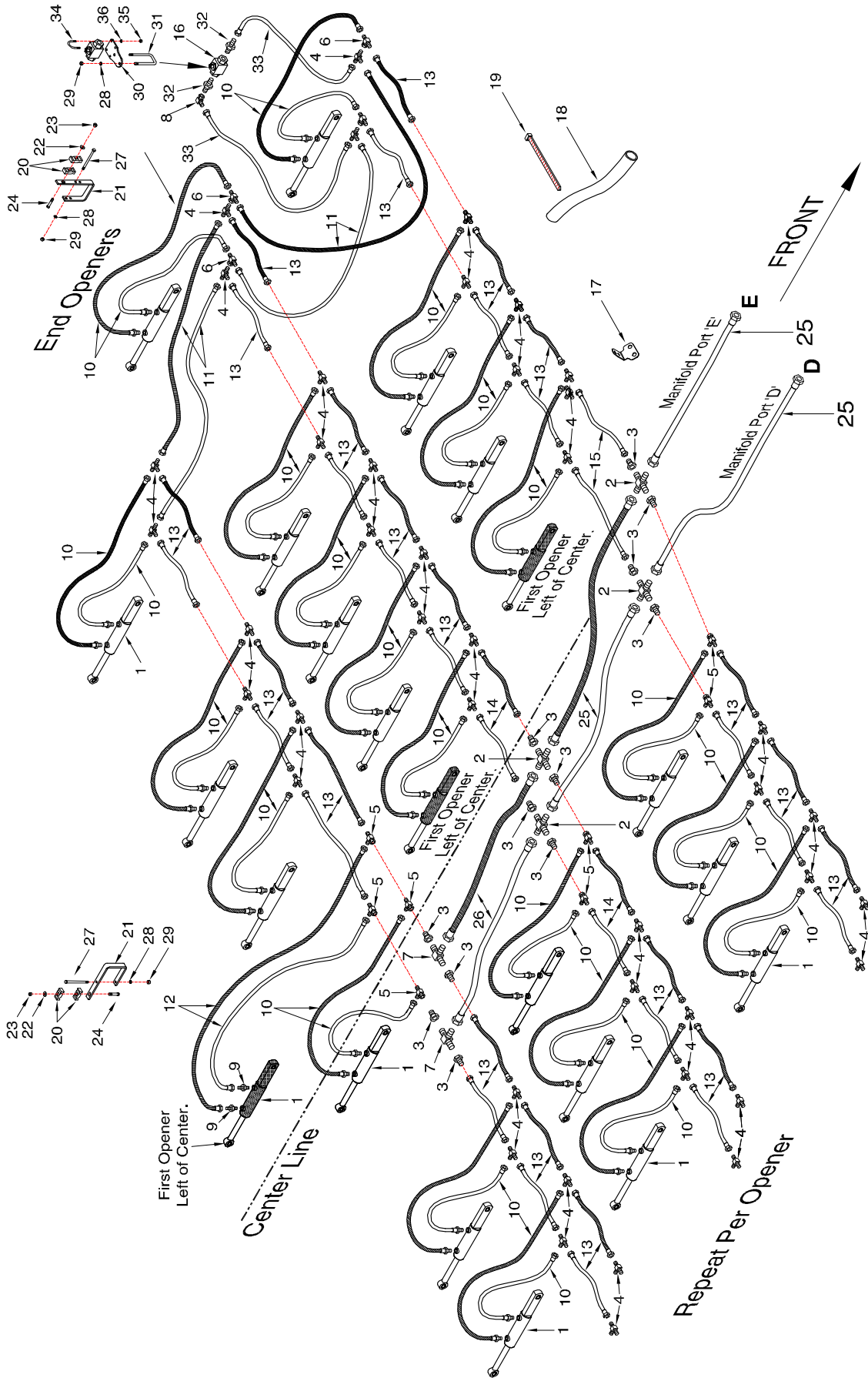

Opener Hydraulics - 12 inch Spacing - 25 & 31 Ft Model - Prior to 2020

Item	Part No.	Description	Qty
1	*****	Cylinder - See Opener Section for details.....	AsReq
2	C-4401	Cross - (4) 7/8-14 MJIC.....	4
3	F10384	Reducer - 7/8-14 MJIC x 9/16-18 MJIC.....	12
4	C-4393	Tee - (3) 9/16-18 MJIC.....	54
5	C-4403	Tee - (2) 9/16-18 MJIC x (1) 9/16-18 FJIC.....	8
6	C14901	Tee - (2) 9/16-18 MJIC x (1) 9/16-18 FJIC.....	8
7	C-4394	Tee - (3) 7/8-14 MJIC	2
8	S29967	90 Elbow - 9/16-18 FJIC x 9/16-18 MJIC	2
9	N29358	Connector - 9/16-18 MJIC x 9/16-18 MORB.....	2
10	S44352	Hyd Hose - 1/4 x 24 Lg w/ #6 9/16-18 FJIC x #6 9/16-18 MORB	60
11	C16652	Hyd Hose - 1/4 x 60 Lg w/9/16-18 FJIC.....	8
12	S22406	Hyd Hose - 1/4 x 72 Lg w/ #6 9/16-18 FJIC.....	2
13	S42969	Hyd Hose - 3/8 x 36 Lg w/ #6 9/16-18 FJIC.....	52
14	S44353	Hyd Hose - 3/8 x 48 Lg w/ #6 9/16-18 FJIC.....	4
15	S47799	Hyd Hose - 3/8 x 60 Lg w/ #6 9/16-18 FJIC.....	2
16	N42880	Lock Valve	2
17	S47976	Hose Holder - Prior to 2020	AsReq
	S72070	Hose Holder - Quantum Opener - 2020 to Present	
18	R480045	Hose Cover - 2 ID x 8 Lg (Bulk/foot)	AsReq
19	D-4951	Nylon Tie Strap - 1/2 x 7 3/8.....	AsReq
20	C-4698	Oil Line Clamp	12
21	C14411	Oil Line Bracket.....	6
22	W-538	Flatwasher - 3/8	6
23	M-3388	Locknut - 3/8	6
24	W-480	Hex Bolt - 3/8 x 2 1/2.....	6
25	K-5685	Hyd Hose - 1/2 x 48 Lg w/7/8-14 FJIC.....	4
26	F-4565	Hyd Hose - 1/2 x 60 Lg w/7/8-14 FJIC.....	2
27	C-3918	Hex Bolt - 3/8 x 5 Lg.....	6
28	W-523	Lockwasher - 3/8.....	10
29	W-514	Hex Nut - 3/8	10
30	S39546	Mount Plate - Ball Valve	2
31	N15097	U-Bolt - 3/8 x 2 3/8 x 5 Lg	2
32	C15348	Connector - 9/16-18 MJIC x 3/4-16 MORB	4
33	C-4552	Hyd Hose - 1/4 x 24Lg w/ #6 9/16-18 FJIC.....	4
34	N34319	U-Bolt - 1/4 x 1 1/2 x 2	4
35	W-512	Hex Nut - 1/4.....	8
36	W-521	Lockwasher - 1/4.....	8

Opener Hydraulics

12 inch Spacing - 25 & 31 Ft Model - 2020 to Present

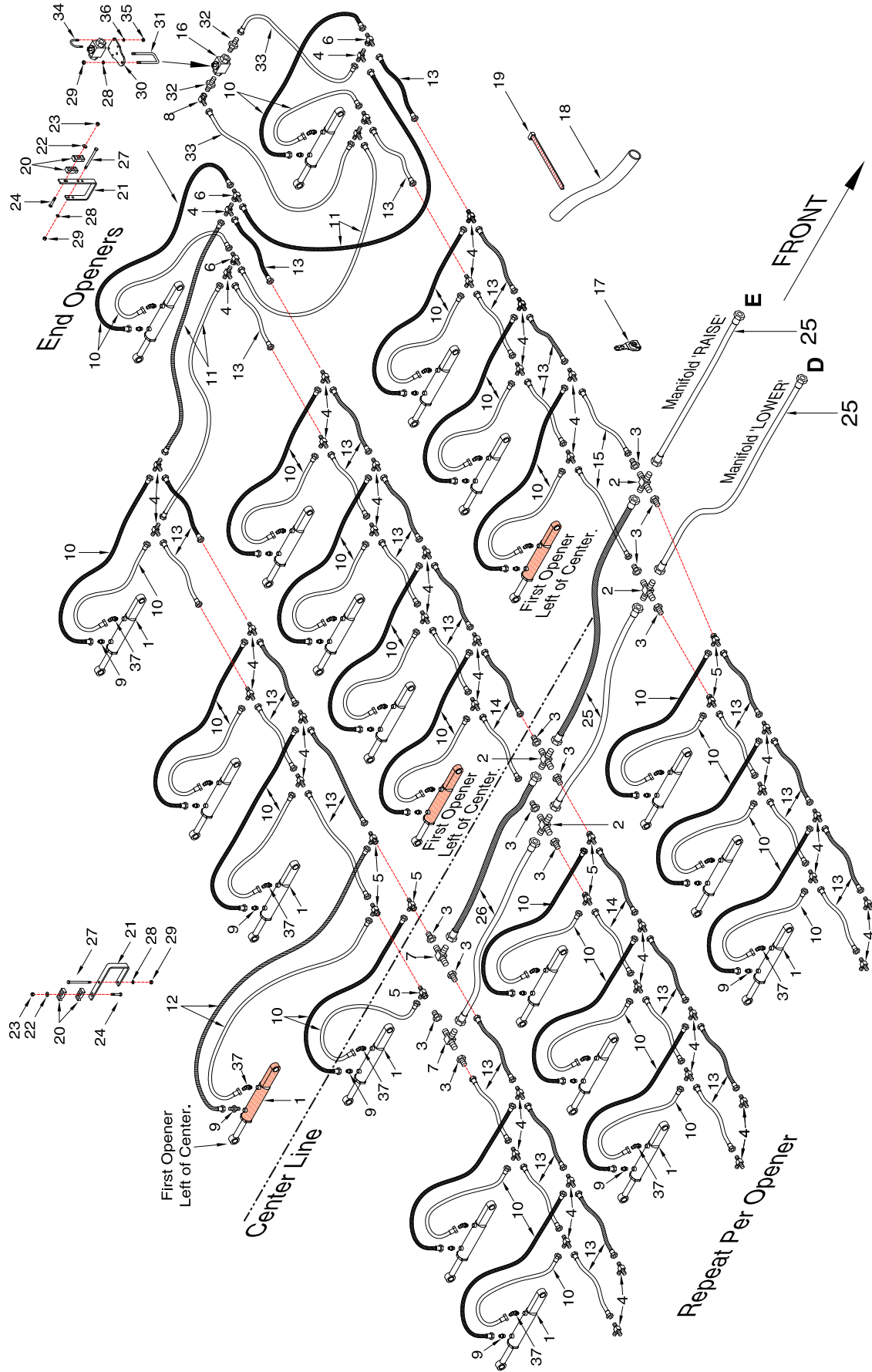

Opener Hydraulics - 12 inch Spacing - 25 & 31 Ft Model - 2020 to Present

Item	Part No.	Description	Qty
1	*****	Cylinder - 1 3/4 Bore x 4 Stroke	AsReq
2	C-4401	Cross - (4) 7/8-14 MJIC.....	4
3	F10384	Reducer - 7/8-14 MJIC x 9/16-18 MJIC.....	12
4	C-4393	Tee - (3) 9/16-18 MJIC.....	54
5	C-4403	Tee - (2) 9/16-18 MJIC x (1) 9/16-18 FJIC.....	8
6	C14901	Tee - (2) 9/16-18 MJIC x (1) 9/16-18 FJIC.....	8
7	C-4394	Tee - (3) 7/8-14 MJIC	2
8	S29967	90 Elbow - 9/16-18 FJIC x 9/16-18 MJIC	2
9	N29358	Connector - 9/16-18 (#06) MJIC x 9/16-18 (#06) MORB.....	AsReq
10	S66243	Hyd Hose - 1/4 x 22 Lg - #6 9/16-18 FJIC Ends (High Flex)	AsReq
11	C16652	Hyd Hose - 1/4 x 60 Lg w/9/16-18 FJIC.....	8
12	S22406	Hyd Hose - 1/4 x 72 Lg w/ #6 9/16-18 FJIC.....	2
13	S42969	Hyd Hose - 3/8 x 36 Lg w/ #6 9/16-18 FJIC.....	52
14	S44353	Hyd Hose - 3/8 x 48 Lg w/ #6 9/16-18 FJIC.....	4
15	S47799	Hyd Hose - 3/8 x 60 Lg w/ #6 9/16-18 FJIC.....	2
16	N42880	Lock Valve	2
17	S72070	Hose Holder - Opener - Low Profile.....	AsReq
18	R480045	Hose Cover - 2 ID x 8 Lg (Bulk/foot)	AsReq
19	D-4951	Nylon Tie Strap - 1/2 x 7 3/8.....	AsReq
20	C-4698	Oil Line Clamp	12
21	C14411	Oil Line Bracket.....	6
22	W-538	Flatwasher - 3/8	6
23	M-3388	Locknut - 3/8	6
24	W-480	Hex Bolt - 3/8 x 2 1/2.....	6
25	K-5685	Hyd Hose - 1/2 x 48 Lg w/7/8-14 FJIC.....	4
26	F-4565	Hyd Hose - 1/2 x 60 Lg w/7/8-14 FJIC.....	2
27	C-3918	Hex Bolt - 3/8 x 5 Lg.....	6
28	W-523	Lockwasher - 3/8.....	10
29	W-514	Hex Nut - 3/8	10
30	S39546	Mount Plate - Ball Valve	2
31	N15097	U-Bolt - 3/8 x 2 3/8 x 5 Lg	2
32	C15348	Connector - 9/16-18 MJIC x 3/4-16 MORB	4
33	C-4552	Hyd Hose - 1/4 x 24Lg w/ #6 9/16-18 FJIC.....	4
34	N34319	U-Bolt - 1/4 x 1 1/2 x 2	4
35	W-512	Hex Nut - 1/4.....	8
36	W-521	Lockwasher - 1/4.....	8
37	N19578	45 Elbow - 9/16-18 (#06) MJIC x 9/16-18 (#06) MORB	AsReq

Opener Hydraulics 12 inch Spacing - 41 Ft to 71 Ft

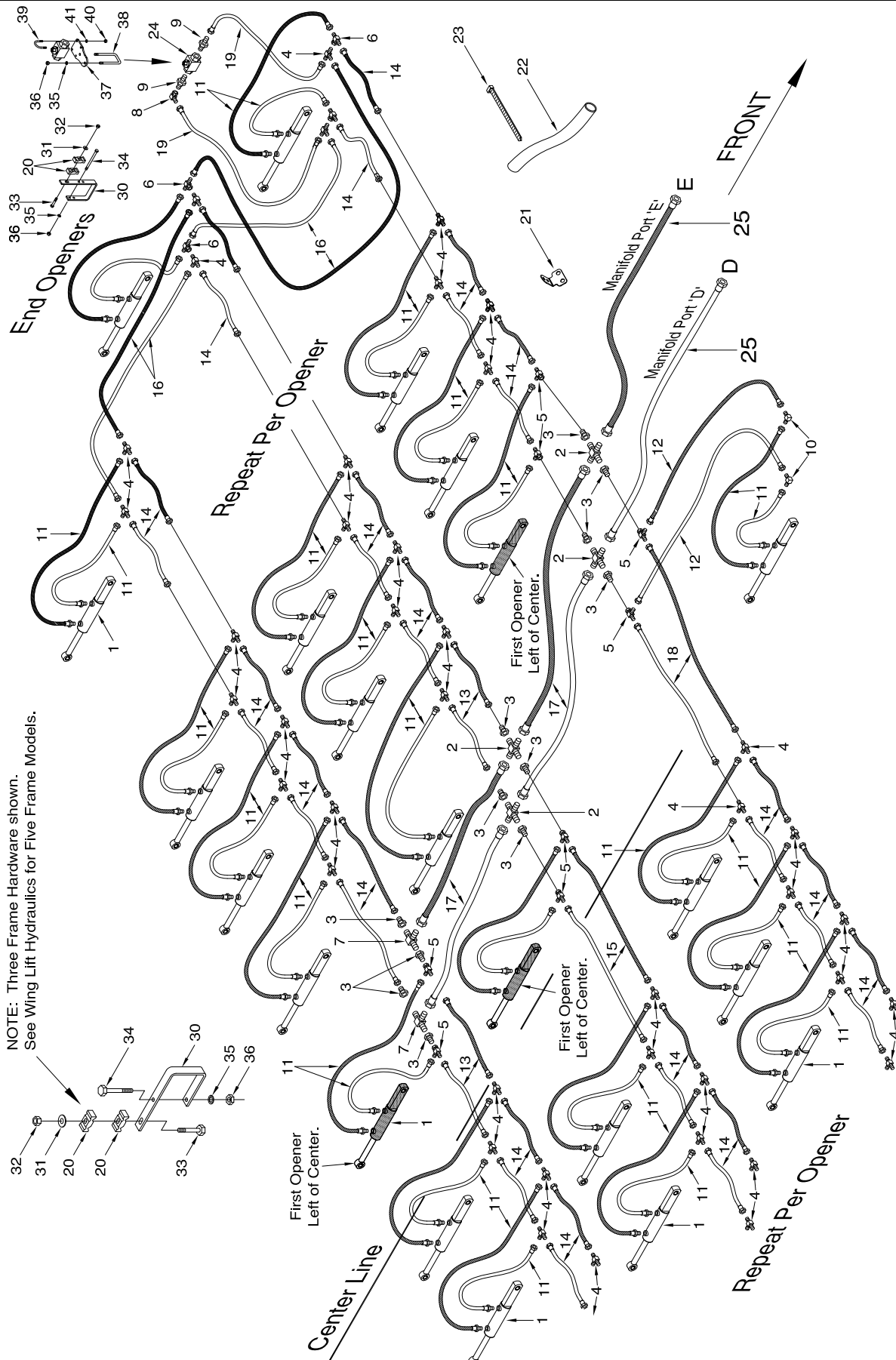

NOTE: Three Frame Hardware shown.
See Wing Lift Hydraulics for Five Frame Models.

Opener Hydraulics - 12 inch Spacing - 41 Ft to 71 Ft

Item	Part No.	Description	Qty
1	*****	Cylinder - See Opener Section for details.....	AsReq
2	C-4401	Cross - (4) 7/8-14 MJIC.....	4
3	F10384	Reducer - 7/8-14 MJIC x 9/16-18 MJIC.....	12
4	C-4393	Tee - (3) 9/16-18 MJIC.....	AsReq
5	C-4403	Tee - (2) 9/16-18 MJIC x (1) 9/16-18 FJIC (MMF).....	12
6	C14901	Tee - (2) 9/16-18 MJIC x (1) 9/16-18 FJIC (MFM).....	8
7	C-4394	Tee - (3) 7/8-14 MJIC.....	2
8	S29967	90 Elbow - 9/16-18 FJIC x 9/16-18 MJIC.....	2
9	C15348	Connector - 9/16-18 MJIC x 3/4-16 MORB.....	4
10	F-3867	90 Elbow - 9/16-18 MJIC.....	2
11	S44352	Hyd Hose - 1/4 x 24 Lg w/ #6 9/16-18 FJIC x #6 9/16-18 MORB.....	AsReq
12	H18267	Hyd Hose - 1/4 x 96 Lg w/9/16-18 FJIC.....	2
13	S42967	Hyd Hose - 3/8 x 30 Lg w/ #6 9/16-18 FJIC.....	4
14	S42969	Hyd Hose - 3/8 x 36 Lg w/ #6 9/16-18 FJIC.....	AsReq
15	S44353	Hyd Hose - 3/8 x 48 Lg w/ #6 9/16-18 FJIC.....	2
16	C16652	Hyd Hose - 1/4 x 60 Lg w/9/16-18 FJIC.....	8
17	K-5685	Hyd Hose - 1/2 x 48 Lg w/7/8-14 FJIC.....	4
18	S48883	Hyd Hose - 3/8 x 52 Lg w/ #6 9/16-18 FJIC.....	2
19	C-4552	Hyd Hose - 1/4 x 24Lg w/ #6 9/16-18 FJIC.....	4
20	C-4698	Oil Line Clamp.....	12
21	S47976	Hose Holder - Prior to 2020.....	AsReq
	S72070	Hose Holder - Quantum Opener - 2020 to Present (Not Shown)	
22	R480045	Hose Cover 2 ID Bulk/foot.....	AsReq
23	D-4951	Nylon Tie Strap - 1/2 x 7 3/8.....	AsReq
24	N42880	Lock Valve.....	2
25	F-4565	Hyd Hose - 1/2 x 60 Lg w/7/8-14 FJIC.....	2
26	S44313	Hose Holder - 61 ft and 71 ft.....	6
26A	S47749	Hose Holder - 51 ft.....	4
27	C-4569	U-Bolt - 5/8 x 4 x 3 1/4 Lg - 51 ft to 71 ft.....	2
28	W-526	Lockwasher - 5/8.....	4
29	W-517	Hex Nut - 5/8.....	4
30	C14411	Oil Line Bracket.....	6
31	W-538	Flatwasher - 3/8.....	6
32	M-3388	Locknut - 3/8.....	6
33	W-480	Hex Bolt - 3/8 x 2 1/2.....	6
34	C-3918	Hex Bolt - 3/8 x 5 Lg.....	6
35	W-523	Lockwasher - 3/8.....	10
36	W-514	Hex Nut - 3/8.....	10
37	S39546	Mount Plate - Ball Valve.....	2
38	N15097	U-Bolt - 3/8 x 2 3/8 x 5 Lg.....	2
39	N34319	U-Bolt - 1/4 x 1 1/2 x 2.....	4
40	W-512	Hex Nut - 1/4.....	8
41	W-521	Lockwasher - 1/4.....	8

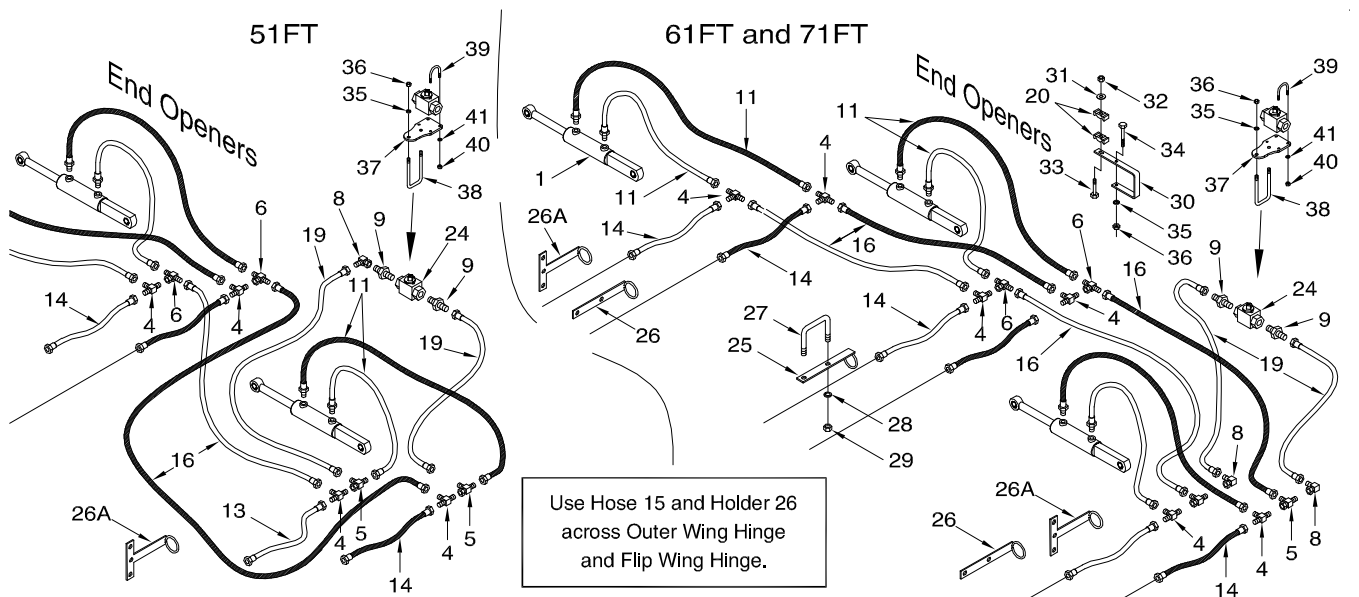

Opener Hydraulics

12 inch Spacing - 80 Ft, 86 Ft and 90 Ft - Prior to 2020

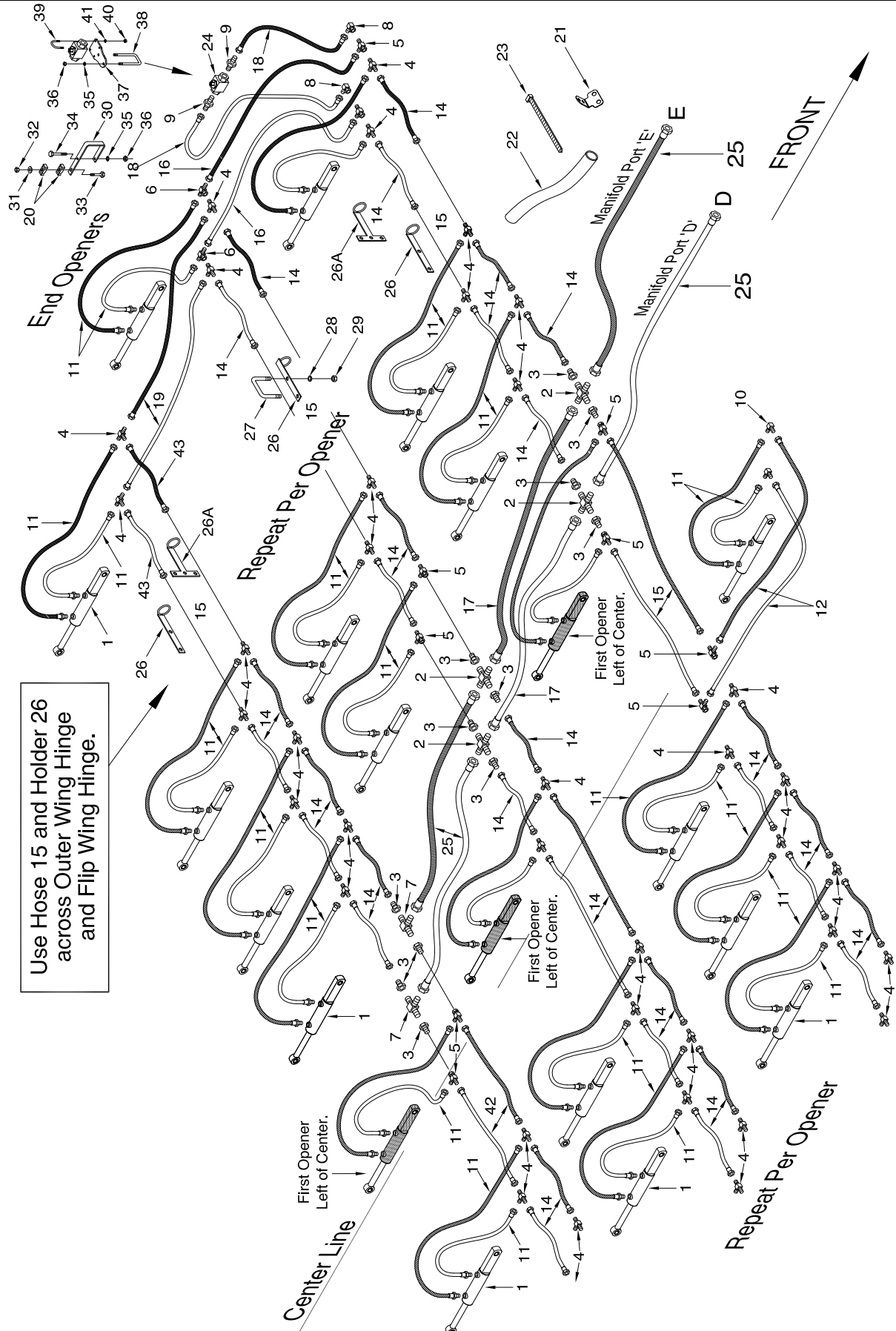

Use Hose 15 and Holder 26 across Outer Wing Hinge and Flip Wing Hinge.

Opener Hydraulics - 12 inch Spacing - 80 Ft, 86 Ft and 90 Ft - Prior to 2020

Item	Part No.	Description	Qty
1	*****	Cylinder - See Opener Section for details.....	AsReq
2	C-4401	Cross - (4) 7/8-14 MJIC.....	4
3	F10384	Reducer - 7/8-14 MJIC x 9/16-18 MJIC.....	12
4	C-4393	Tee - (3) 9/16-18 MJIC.....	AsReq
5	C-4403	Tee - (2) 9/16-18 MJIC x (1) 9/16-18 FJIC (MMF).....	8
6	C14901	Tee - (2) 9/16-18 MJIC x (1) 9/16-18 FJIC (MFM).....	8
7	C-4394	Tee - (3) 7/8-14 MJIC	2
8	S29967	90 Elbow - 9/16-18 FJIC x 9/16-18 MJIC	2
9	C15348	Connector - 9/16-18 MJIC x 3/4-16 MORB	4
10	F-3867	90 Elbow - 9/16-18 MJIC.....	2
11	S44352	Hyd Hose - 1/4 x 24 Lg w/ #6 9/16-18 FJIC x #6 9/16-18 MORB	AsReq
12	H18267	Hyd Hose - 1/4 x 96 Lg w/9/16-18 FJIC.....	2
13	S42967	Hyd Hose - 3/8 x 30 Lg w/ #6 9/16-18 FJIC.....	4
14	S42969	Hyd Hose - 3/8 x 36 Lg w/ #6 9/16-18 FJIC.....	AsReq
15	S44353	Hyd Hose - 3/8 x 48 Lg w/ #6 9/16-18 FJIC.....	4
16	C16652	Hyd Hose - 1/4 x 60 Lg w/9/16-18 FJIC.....	8
17	K-5685	Hyd Hose - 1/2 x 48 Lg w/7/8-14 FJIC.....	2
18	C-4552	Hyd Hose - 1/4 x 24Lg w/ #6 9/16-18 FJIC.....	4
19	S22406	Hyd Hose - 1/4 x 72 Lg w/ #6 9/16-18 FJIC - 80 & 86 ft	4
	H18266	Hyd Hose - 1/4 x 80 Lg w/ #6 9/16-18 FJIC - 90 ft.....	4
20	C-4698	Oil Line Clamp	12
21	S47976	Hose Holder - Prior to 2020	AsReq
	S72070	Hose Holder - Quantum Opener - 2020 to Present	
22	R480045	Hose Cover 2 ID Bulk/foot.....	AsReq
23	D-4951	Nylon Tie Strap - 1/2 x 7 3/8.....	AsReq
24	N42880	Lock Valve	2
25	F-4565	Hyd Hose - 1/2 x 60 Lg w/7/8-14 FJIC.....	4
26	S44313	Hose Holder - Between Inner and Outer Wing.....	6
26A	S47749	Hose Holder - Between Outer and Flip Wing	4
27	C-4569	U-Bolt - 5/8 x 4 x 3 1/4 Lg	2
28	W-526	Lockwasher - 5/8.....	4
29	W-517	Hex Nut - 5/8.....	4
30	C14411	Oil Line Bracket.....	6
31	W-538	Flatwasher - 3/8.....	6
32	M-3388	Locknut - 3/8	6
33	W-480	Hex Bolt - 3/8 x 2 1/2.....	6
34	C-3918	Hex Bolt - 3/8 x 5 Lg.....	6
35	W-523	Lockwasher - 3/8.....	14
36	W-514	Hex Nut - 3/8.....	14
37	S39546	Mount Plate - Ball Valve	2
38	N15097	U-Bolt - 3/8 x 2 3/8 x 5 Lg	2
39	N34319	U-Bolt - 1/4 x 1 1/2 x 2	4
40	W-512	Hex Nut - 1/4.....	8
41	W-521	Lockwasher - 1/4.....	8
42	S47799	Hyd Hose - 3/8 x 60 Lg w/ #6 9/16-18 FJIC.....	2
43	S42969	Hyd Hose - 3/8 x 36 Lg w/ #6 9/16-18 FJIC - 80 & 86 ft	4
	S22406	Hyd Hose - 1/4 x 72 Lg w/ #6 9/16-18 FJIC - 90 ft.....	4

Opener Hydraulics 12 inch Spacing - 80 Ft - 2020 to Present

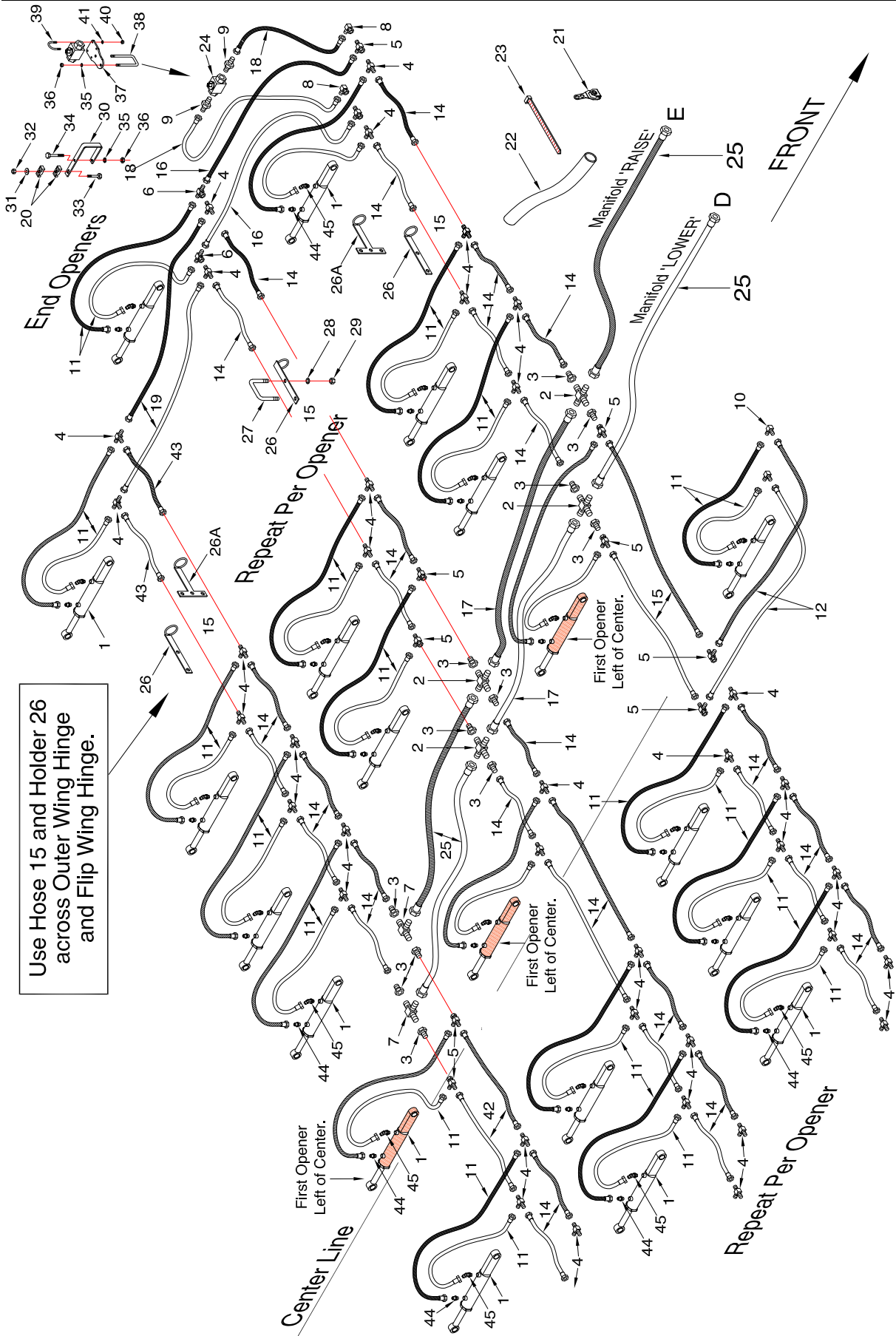

Opener Hydraulics - 12 inch Spacing - 80 Ft - 2020 to Present

Item	Part No.	Description	Qty
1	*****	Cylinder	AsReq
2	C-4401	Cross - (4) 7/8-14 MJIC.....	4
3	F10384	Reducer - 7/8-14 MJIC x 9/16-18 MJIC.....	12
4	C-4393	Tee - (3) 9/16-18 MJIC.....	AsReq
5	C-4403	Tee - (2) 9/16-18 MJIC x (1) 9/16-18 FJIC (MMF).....	8
6	C14901	Tee - (2) 9/16-18 MJIC x (1) 9/16-18 FJIC (MFM).....	8
7	C-4394	Tee - (3) 7/8-14 MJIC	2
8	S29967	90 Elbow - 9/16-18 FJIC x 9/16-18 MJIC	4
9	C15348	Connector - 9/16-18 MJIC x 3/4-16 MORB	4
10	F-3867	90 Elbow - 9/16-18 MJIC.....	2
11	S66243	Hyd Hose - 1/4 x 22 Lg - #6 9/16-18 FJIC Ends (High Flex)	160
12	H18267	Hyd Hose - 1/4 x 96 Lg w/9/16-18 FJIC.....	2
13	S42967	Hyd Hose - 3/8 x 30 Lg w/ #6 9/16-18 FJIC.....	4
14	S42969	Hyd Hose - 3/8 x 36 Lg w/ #6 9/16-18 FJIC.....	AsReq
15	S44353	Hyd Hose - 3/8 x 48 Lg w/ #6 9/16-18 FJIC.....	4
16	C16652	Hyd Hose - 1/4 x 60 Lg w/9/16-18 FJIC.....	8
17	K-5685	Hyd Hose - 1/2 x 48 Lg w/7/8-14 FJIC.....	2
18	C-4552	Hyd Hose - 1/4 x 24Lg w/ #6 9/16-18 FJIC.....	4
19	S22406	Hyd Hose - 1/4 x 72 Lg w/ #6 9/16-18 FJIC - 80 & 86 ft	4
20	C-4698	Oil Line Clamp	12
21	S72070	Hose Holder - Opener - Low Profile.....	AsReq
22	R480045	Hose Cover 2 ID Bulk/foot.....	AsReq
23	D-4951	Nylon Tie Strap - 1/2 x 7 3/8.....	AsReq
24	N42880	Lock Valve	2
25	F-4565	Hyd Hose - 1/2 x 60 Lg w/7/8-14 FJIC.....	4
26	S44313	Hose Holder - Between Inner and Outer Wing.....	6
26A	S47749	Hose Holder - Between Outer and Flip Wing	4
27	C-4569	U-Bolt - 5/8 x 4 x 3 1/4 Lg	2
28	W-526	Lockwasher - 5/8.....	4
29	W-517	Hex Nut - 5/8.....	4
30	C14411	Oil Line Bracket.....	6
31	W-538	Flatwasher - 3/8.....	6
32	M-3388	Locknut - 3/8	6
33	W-480	Hex Bolt - 3/8 x 2 1/2 Lg.....	6
34	C-3918	Hex Bolt - 3/8 x 5 Lg.....	6
35	W-523	Lockwasher - 3/8.....	14
36	W-514	Hex Nut - 3/8.....	14
37	S39546	Mount Plate - Ball Valve	2
38	N15097	U-Bolt - 3/8 x 2 3/8 x 5 Lg	2
39	N34319	U-Bolt - 1/4 x 1 1/2 x 2 UL.....	4
40	W-512	Hex Nut - 1/4.....	8
41	W-521	Lockwasher - 1/4.....	8
42	S47799	Hyd Hose - 3/8 x 60 Lg w/ #6 9/16-18 FJIC.....	2
43	S42969	Hyd Hose - 3/8 x 36 Lg w/ #6 9/16-18 FJIC - 80 & 86 ft	4
44	N19578	45 Elbow - 9/16-18 (#06) MJIC x 9/16-18 (#06) MORB	80
45	N29358	Connector - 9/16-18 (#06) MJIC x 9/16-18 (#06) MORB.....	80

Opener Hydraulics 12 inch Spacing - 90 Ft - 2020 to Present

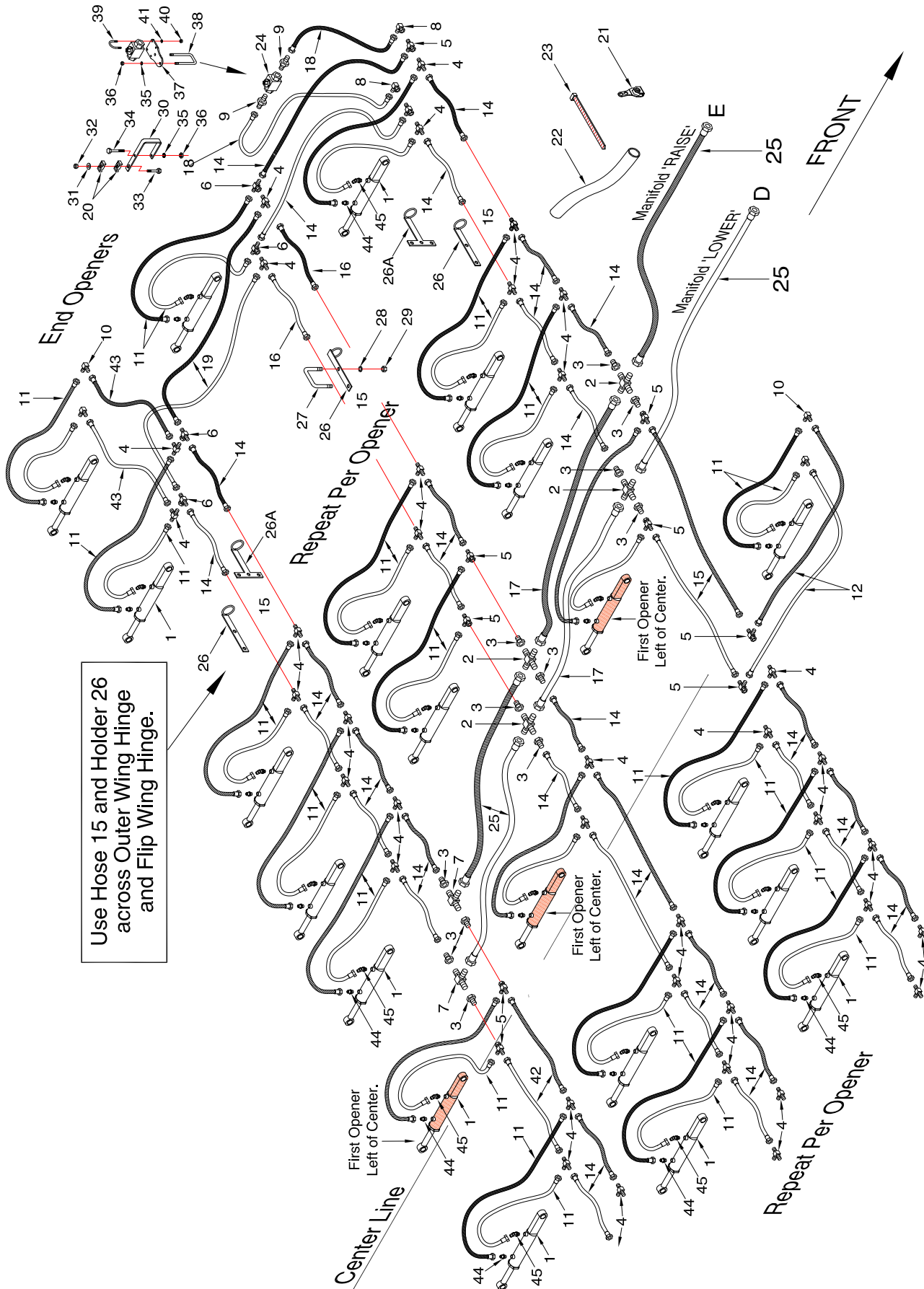

Opener Hydraulics - 12 inch Spacing - 90 Ft - 2020 to Present

Item	Part No.	Description	Qty
1	*****	Cylinder	AsReq
2	C-4401	Cross - (4) 7/8-14 MJIC.....	4
3	F10384	Reducer - 7/8-14 MJIC x 9/16-18 MJIC.....	12
4	C-4393	Tee - (3) 9/16-18 MJIC.....	AsReq
5	C-4403	Tee - (2) 9/16-18 MJIC x (1) 9/16-18 FJIC (MMF).....	8
6	C14901	Tee - (2) 9/16-18 MJIC x (1) 9/16-18 FJIC (MFM).....	8
7	C-4394	Tee - (3) 7/8-14 MJIC	2
8	S29967	90 Elbow - 9/16-18 FJIC x 9/16-18 MJIC	4
9	C15348	Connector - 9/16-18 MJIC x 3/4-16 MORB	4
10	F-3867	90 Elbow - 9/16-18 MJIC.....	4
11	S66243	Hyd Hose - 1/4 x 22 Lg - #6 9/16-18 FJIC Ends (High Flex)	180
12	H18267	Hyd Hose - 1/4 x 96 Lg w/9/16-18 FJIC.....	2
13	S42967	Hyd Hose - 3/8 x 30 Lg w/ #6 9/16-18 FJIC.....	4
14	S42969	Hyd Hose - 3/8 x 36 Lg w/ #6 9/16-18 FJIC.....	AsReq
15	S44353	Hyd Hose - 3/8 x 48 Lg w/ #6 9/16-18 FJIC.....	4
16	C16652	Hyd Hose - 1/4 x 60 Lg w/9/16-18 FJIC.....	8
17	K-5685	Hyd Hose - 1/2 x 48 Lg w/7/8-14 FJIC.....	2
18	C-4552	Hyd Hose - 1/4 x 24Lg w/ #6 9/16-18 FJIC	4
19	H18266	Hyd Hose - 1/4 x 80 Lg w/ #6 9/16-18 FJIC - 90 ft.....	4
20	C-4698	Oil Line Clamp	12
21	S72070	Hose Holder - Opener - Low Profile.....	AsReq
22	R480045	Hose Cover 2 ID Bulk/foot.....	AsReq
23	D-4951	Nylon Tie Strap - 1/2 x 7 3/8.....	AsReq
24	N42880	Lock Valve	2
25	F-4565	Hyd Hose - 1/2 x 60 Lg w/7/8-14 FJIC.....	4
26	S44313	Hose Holder - Between Inner and Outer Wing.....	6
26A	S47749	Hose Holder - Between Outer and Flip Wing	4
27	C-4569	U-Bolt - 5/8 x 4 x 3 1/4 Lg	2
28	W-526	Lockwasher - 5/8.....	4
29	W-517	Hex Nut - 5/8.....	4
30	C14411	Oil Line Bracket.....	6
31	W-538	Flatwasher - 3/8	6
32	M-3388	Locknut - 3/8	6
33	W-480	Hex Bolt - 3/8 x 2 1/2 Lg.....	6
34	C-3918	Hex Bolt - 3/8 x 5 Lg.....	6
35	W-523	Lockwasher - 3/8.....	14
36	W-514	Hex Nut - 3/8.....	14
37	S39546	Mount Plate - Ball Valve	2
38	N15097	U-Bolt - 3/8 x 2 3/8 x 5 Lg	2
39	N34319	U-Bolt - 1/4 x 1 1/2 x 2 UL.....	4
40	W-512	Hex Nut - 1/4.....	8
41	W-521	Lockwasher - 1/4.....	8
42	S47799	Hyd Hose - 3/8 x 60 Lg w/ #6 9/16-18 FJIC.....	2
43	S22406	Hyd Hose - 1/4 x 72 Lg w/ #6 9/16-18 FJIC - 90 ft.....	4
44	N19578	45 Elbow - 9/16-18 (#06) MJIC x 9/16-18 (#06) MORB	90
45	N29358	Connector - 9/16-18 (#06) MJIC x 9/16-18 (#06) MORB.....	90

Opener Hydraulics

12 inch Spacing - 41 Ft to 90 Ft - High Speed

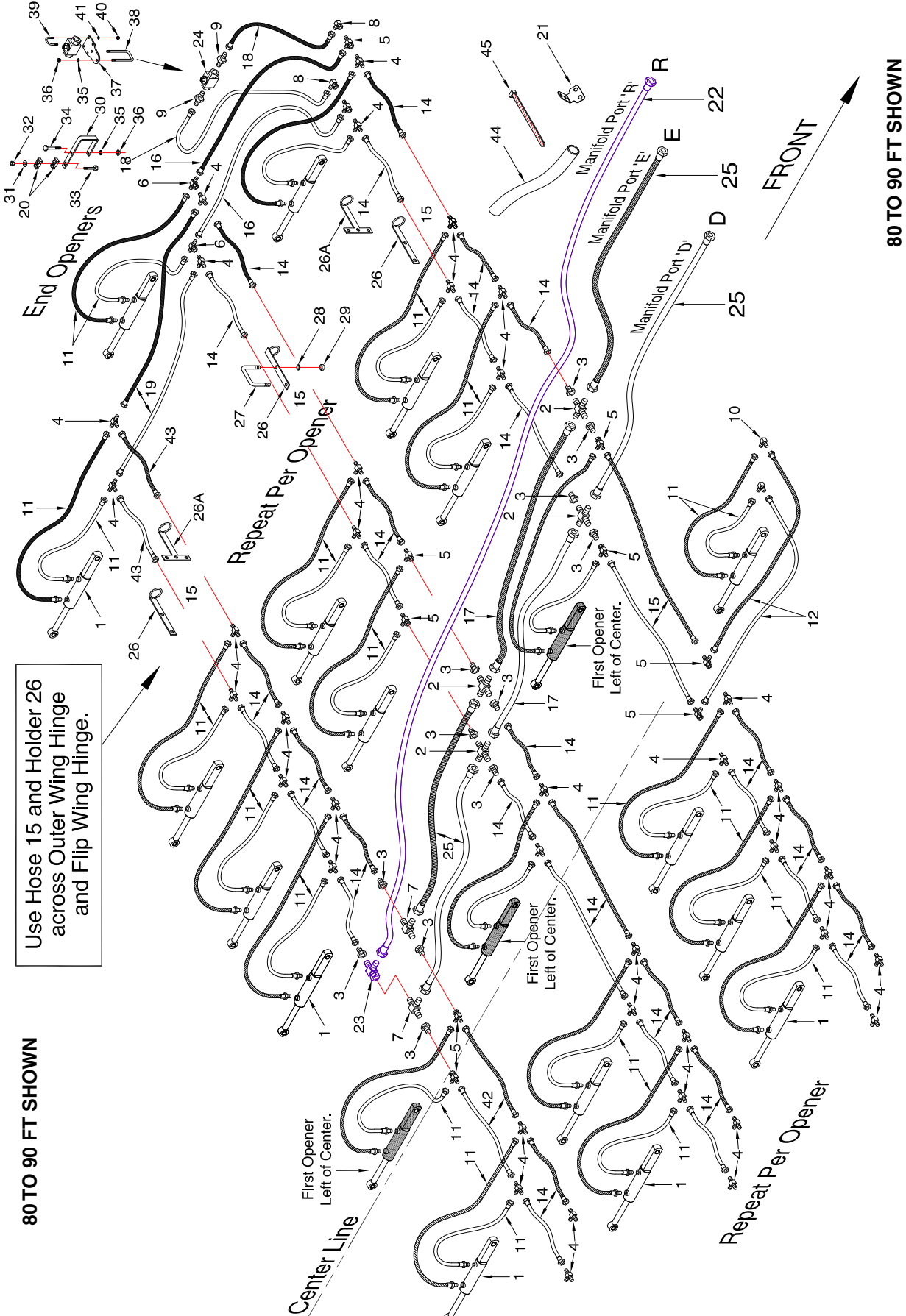

80 TO 90 FT SHOWN

Use Hose 15 and Holder 26 across Outer Wing Hinge and Flip Wing Hinge.

80 TO 90 FT SHOWN

Opener Hydraulics - 12 inch Spacing - 41 Ft to 90 Ft - High Speed

Item	Part No.	Description	Qty
1	*****	Cylinder - See Opener Section for details.....	AsReq
2	C-4401	Cross - (4) 7/8-14 MJIC.....	4
3	F10384	Reducer - 7/8-14 MJIC x 9/16-18 MJIC.....	12
4	C-4393	Tee - (3) 9/16-18 MJIC.....	AsReq
5	C-4403	Tee - (2) 9/16-18 MJIC x (1) 9/16-18 FJIC (MMF).....	8
6	C14901	Tee - (2) 9/16-18 MJIC x (1) 9/16-18 FJIC (MFM).....	8
7	C-4394	Tee - (3) 7/8-14 MJIC	2
8	S29967	90 Elbow - 9/16-18 FJIC x 9/16-18 MJIC	2
9	C15348	Connector - 9/16-18 MJIC x 3/4-16 MORB	4
10	F-3867	90 Elbow - 9/16-18 MJIC.....	2
11	S44352	Hyd Hose - 1/4 x 24 Lg w/ #6 9/16-18 FJIC x #6 9/16-18 MORB	AsReq
12	H18267	Hyd Hose - 1/4 x 96 Lg w/9/16-18 FJIC.....	2
13	S42967	Hyd Hose - 3/8 x 30 Lg w/ #6 9/16-18 FJIC.....	4
14	S42969	Hyd Hose - 3/8 x 36 Lg w/ #6 9/16-18 FJIC.....	AsReq
15	S44353	Hyd Hose - 3/8 x 48 Lg w/ #6 9/16-18 FJIC.....	4
16	C16652	Hyd Hose - 1/4 x 60 Lg w/9/16-18 FJIC.....	8
17	K-5685	Hyd Hose - 1/2 x 48 Lg w/7/8-14 FJIC.....	2
18	C-4552	Hyd Hose - 1/4 x 24Lg w/ #6 9/16-18 FJIC.....	4
19	S22406	Hyd Hose - 1/4 x 72 Lg w/ #6 9/16-18 FJIC - 80 & 86 ft	4
	H18266	Hyd Hose - 1/4 x 80 Lg w/ #6 9/16-18 FJIC - 90 ft.....	4
20	C-4698	Oil Line Clamp	12
21	S47976	Hose Holder - Prior to 2020	AsReq
	S72070	Hose Holder - Quantum Opener - 2020 to Present	
22	S39504	Hyd Hose - 1/2 x 168 Lg w/7/8-14 FJIC (Port R).....(High Speed Kit).....	1
23	H18746	Tee - Swivel - (2) 7/8-14 MJIC x (1) 7/8-14 FJIC (MMF)....(High Speed Kit).....	1
24	N42880	Lock Valve	2
25	F-4565	Hyd Hose - 1/2 x 60 Lg w/7/8-14 FJIC.....	4
26	S44313	Hose Holder - Between Inner and Outer Wing.....	6
26A	S47749	Hose Holder - Between Outer and Flip Wing	4
27	C-4569	U-Bolt - 5/8 x 4 x 3 1/4 Lg	2
28	W-526	Lockwasher - 5/8.....	4
29	W-517	Hex Nut - 5/8.....	4
30	C14411	Oil Line Bracket.....	6
31	W-538	Flatwasher - 3/8.....	6
32	M-3388	Locknut - 3/8	6
33	W-480	Hex Bolt - 3/8 x 2 1/2.....	6
34	C-3918	Hex Bolt - 3/8 x 5 Lg.....	6
35	W-523	Lockwasher - 3/8.....	14
36	W-514	Hex Nut - 3/8.....	14
37	S39546	Mount Plate - Ball Valve	2
38	N15097	U-Bolt - 3/8 x 2 3/8 x 5 Lg	2
39	N34319	U-Bolt - 1/4 x 1 1/2 x 2	4
40	W-512	Hex Nut - 1/4.....	8
41	W-521	Lockwasher - 1/4.....	8
42	S47799	Hyd Hose - 3/8 x 60 Lg w/ #6 9/16-18 FJIC.....	2
43	S42969	Hyd Hose - 3/8 x 36 Lg w/ #6 9/16-18 FJIC - 80 & 86 ft	4
	S22406	Hyd Hose - 1/4 x 72 Lg w/ #6 9/16-18 FJIC - 90 ft.....	4
44	R480045	Hose Cover 2 ID Bulk/foot.....	AsReq
45	D-4951	Nylon Tie Strap - 1/2 x 7 3/8.....	AsReq

**Opener Hydraulics
Tow Between Air Cart - 7000 Series - Prior to 2016**

7000 Series Air Cart

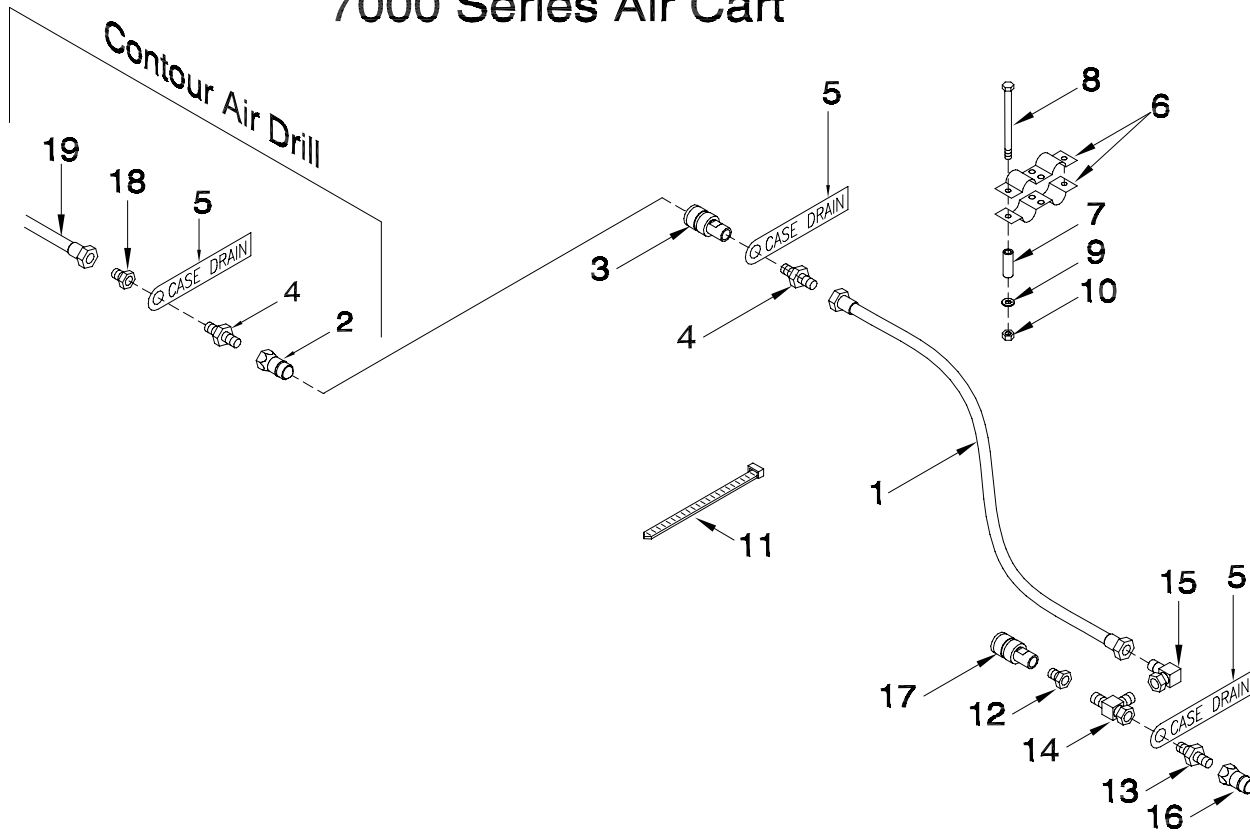

Item	Part No.	Description	Qty
KIT ITEMS - TOW BETWEEN			
1	C26337	Hyd Hose - 1/2 x 276 Lg w/7/8-14 FJIC	1
2	N34498	Male Tip - 7/8-14 MORB.....	1
3	N34488	Pioneer Coupler - 7/8-14 FORB.....	1
4	N36489	Connector - 7/8-14 MORB x 7/8-14 MJIC	2
5	S44468	Tag - Hose ID - Reducing Valve - CASE DRAIN.....	3
6	N16608	Coupler Clamp - Female Pioneer.....	2
7	N19458	Spacer - 2	2
8	H-4696	Hex Bolt - 1/4 x 3 Lg.....	2
9	W-521	Lockwasher - 1/4.....	4
10	W-512	Hex Nut - 1/4.....	4
11	D-4951	Nylon Tie Strap - 7 3/8 Lg.....	2
ITEMS MOVED FROM CONTOUR AIR DRILL			
12	N34620	Connector - Swivel - 7/8-14 MORB x 7/8-14 FJIC	1
13	C14840	Connector - 3/4-16 MORB x 7/8-14 MJIC	1
14	H18746	Tee - Swivel - (2) 7/8-14 MJIC x (1) 7/8-14 FJIC (MMF)	1
15	K-5806	90 Elbow - Swivel - 7/8-14 MJIC x 7/8-14 FJIC	1
16	N34443	Male Tip - 3/4-16 MORB.....	1
17	N34488	Pioneer Coupler - 7/8-14 FORB.....	1
CONTOUR AIR DRILL ITEMS			
18	F10384	Reducer - 9/16-18 MJIC x 7/8-14 FJIC	3
19	C26341	Hyd Hose - 1/4 x 282 Lg w/9/16-18 FJIC	1

8XL Series Air Cart

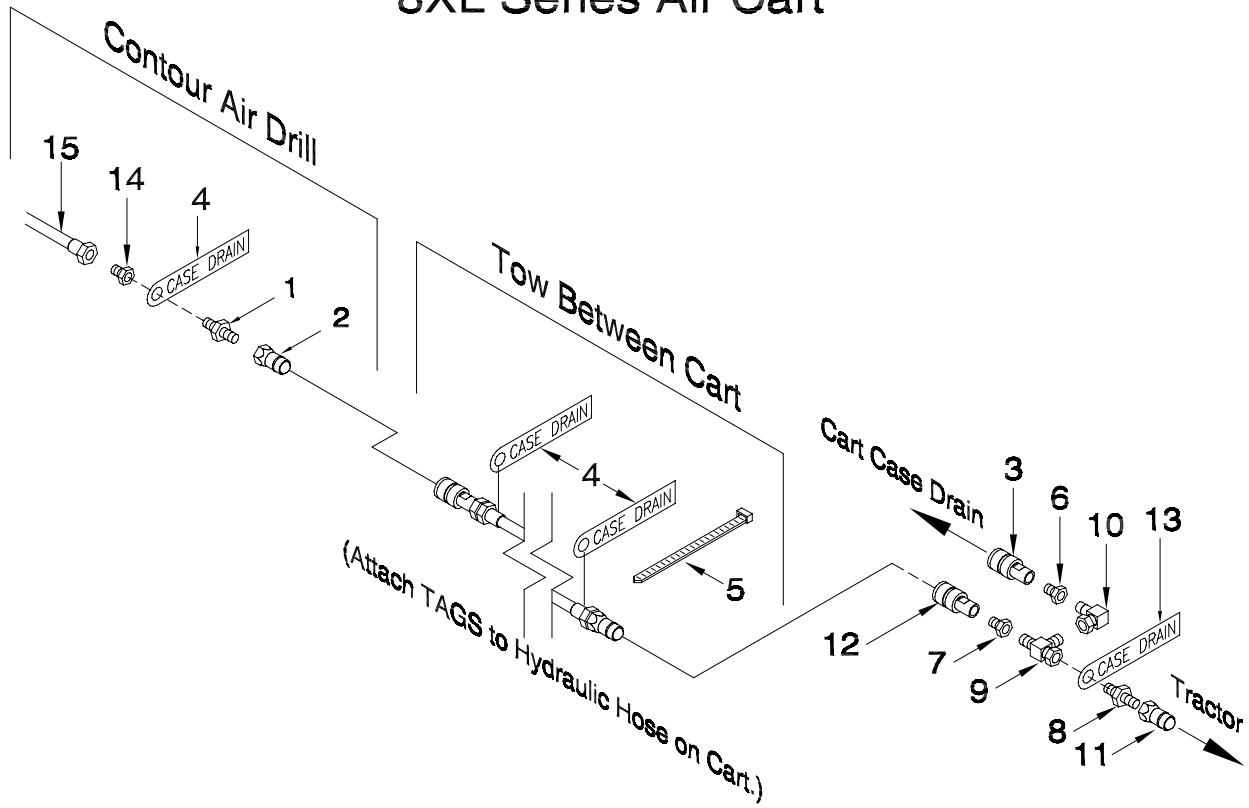

Item	Part No.	Description	Qty
KIT ITEMS - TOW BETWEEN			
1	C14840	Connector - 3/4-16 MORB x 7/8-14 MJIC.....	6
2	N34498	Male Tip - 7/8-14 MORB.....	1
3	N34488	Pioneer Coupler - 7/8-14 FORB.....	1
4	S44468	Tag - Hose ID - Reducing Valve - CASE DRAIN.....	2
5	D-4951	Nylon Tie Strap - 7 3/8 Lg.....	2
6	N34620	Connector - Swivel - 7/8-14 MORB x 7/8-14 FJIC	2
ITEMS MOVED FROM CONTOUR AIR DRILL			
7	N34620	Connector - Swivel - 7/8-14 MORB x 7/8-14 FJIC	1
8	C14840	Connector - 3/4-16 MORB x 7/8-14 MJIC	1
9	H18746	Tee - Swivel - (2) 7/8-14 MJIC x (1) 7/8-14 FJIC (MMF)	1
10	K-5806	90 Elbow - Swivel - 7/8-14 MJIC x 7/8-14 FJIC	1
11	N34443	Male Tip - 3/4-16 MORB.....	1
12	N34488	Pioneer Coupler - 7/8-14 FORB.....	1
13	S44468	Tag - Hose ID - Reducing Valve - CASE DRAIN.....	1
CONTOUR AIR DRILL ITEMS			
14	F10384	Reducer - 9/16-18 MJIC x 7/8-14 FJIC	3
15	C26341	Hyd Hose - 1/4 x 282 Lg w/9/16-18 FJIC.....	1

Pressure Control Digital Gauge - Standard Passive System

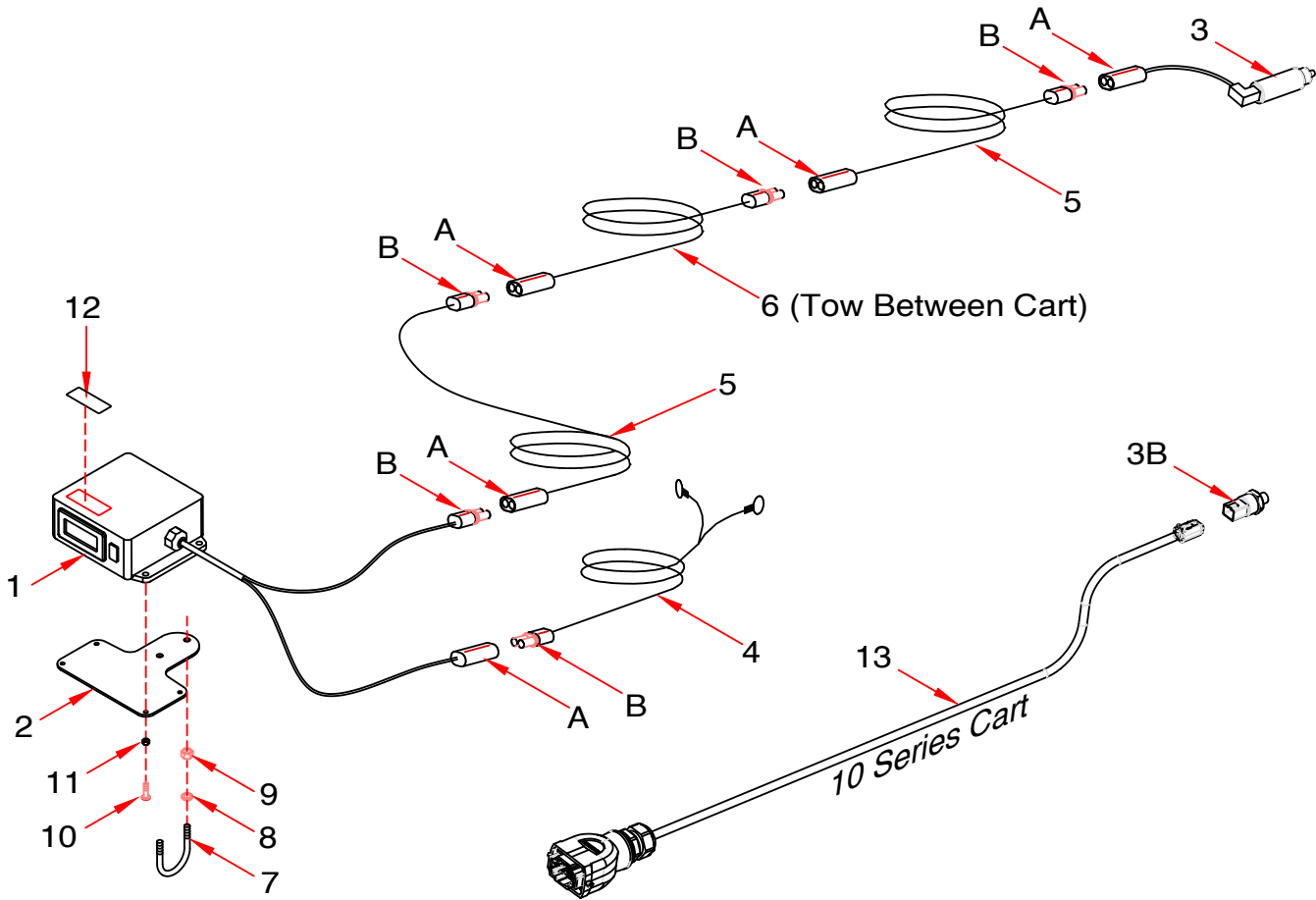

Note: TOPCON option only uses items 3, 5, and 6.

Apollo System does not use any of the above components. See 9 Series or 10 Series Parts Manual for details.

Item	Part No.	Description	Qty
1	S42999	Digital Gauge (Includes item 12) Fuse GMA-500-R.....	1
2	S44350	Mounting Bracket - Digital Gauge	1
3	S49545	Pressure Transducer	1
3A	N58963	Pressure Transducer - Apollo System - Prior to 2018 (Not included in Kit N46098)	
3B	K62977	Pressure Transducer - Apollo System - 2018 (Not included in Kit N46098)	
4	N27609	Power Cable - Monitor	1
5	N37018	Extension Cable - 20 ft Lg.....	2
6	N37020	Extension Cable - 30 ft Lg (Tow Between Air Cart)	1
7	N34319	U-Bolt - 1/4 x 1 1/2 x 1 3/4 Lg	1
8	W-521	Lockwasher - 1/4.....	2
9	W-512	Hex Nut - 1/4	2
10	N29486	Machine Screw - #8 x 5/8 Lg.....	4
11	N16564	Locknut - #8 - Serrated	4
12	S44464	Decal - Digital Gauge Identification.....	1
	N46098	Kit: Contour Pressure Display (Includes above items)	
13	N74006	Harness - C2 Drill Pressure Input - 10 Series Air Cart with Harting connection	1
		Replacement Connectors	
A	N29384	Weather Pak Connector - BLACK - 2 Pin Plug	
B	N29385	Weather Pak Connector - BLACK - 2 Pin Socket	

Pressure Control JEM Pressure Control System - for Active Hydraulic Option

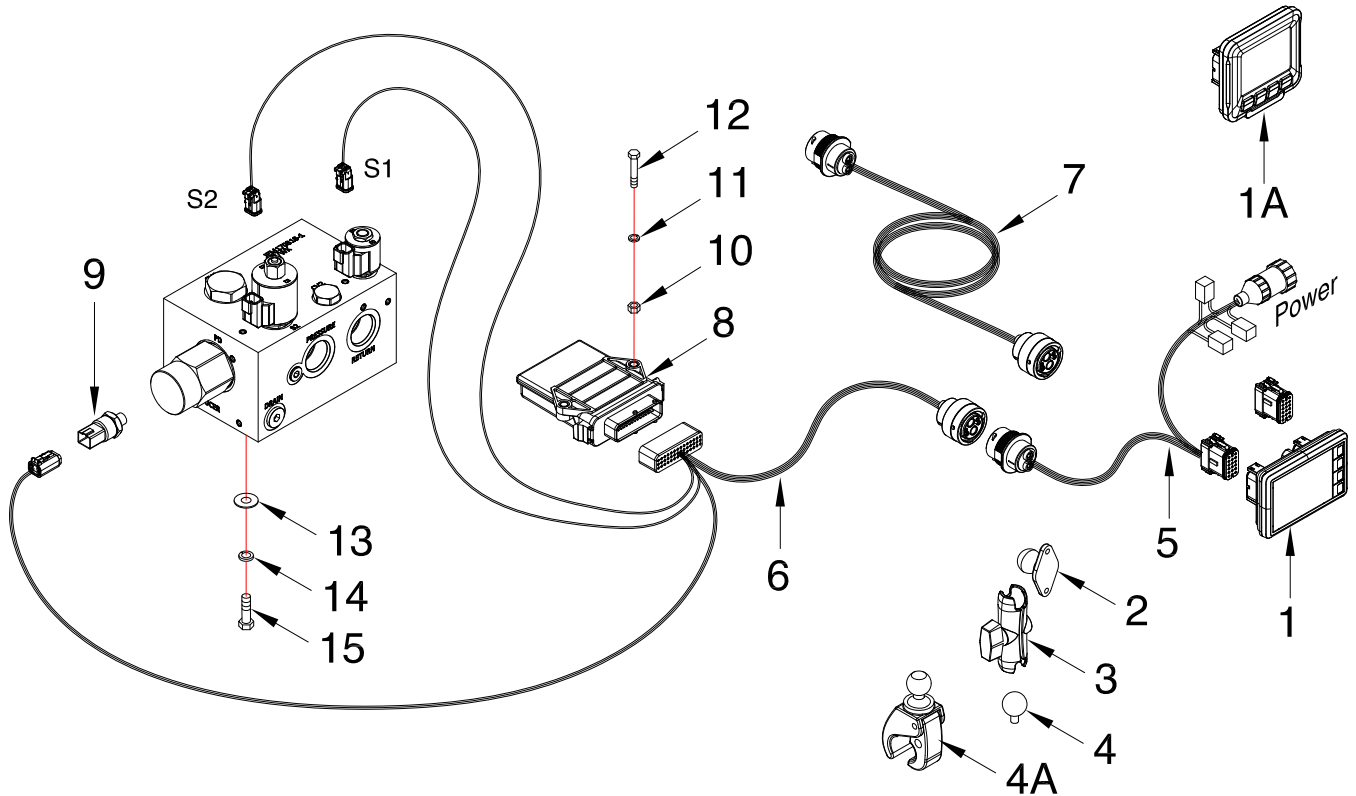

Item	Part No.	Description	Qty
1	N72180	CC Pilot Display Version 2 - 3 1/2 Full Color (New for July 2021) Shown.....	1
1A	N65145	CC Pilot Display - 3 1/2 Full Color (Discontinued).....	1
2	N45644	Ram Mount - 1 7/16 x 1 5/16.....	1
3	N65147	Ram Short Arm	1
4	N65148	Ram Ball - 1 Diameter.....	1
4A	N65146	Ram Claw Mount	
5	N65141	Harness - Tractor (1000545)	1
6	N65142	Harness - Implement (1000546)	1
7	N65149	Harness - Extension (Tow Between Carts) (1000626)	1
8	N65143	ESX-10Xp ECU.....	1
9	K62977	Pressure Transducer	1
10	W-512	Hex Nut - 1/4.....	2
11	W-521	Lockwasher - 1/4.....	2
12	C-1471	Hex Bolt - 1/4 x 1 3/4 Lg.....	2
13	W-538	Flatwasher - 7/16 ID x 1 OD x 14 GA.....	4
14	W-523	Lockwasher - 3/8.....	4
15	W-475	Hex Bolt - 3/8 x 1 Lg.....	4
	N72181	CC Pilot Display Kit - (Includes Items 1 to 4) (New for July 2021)	
	N65140	CC Pilot Display Kit - (Includes Items 1A to 4) (Discontinued)	

Pressure Control 9 Series Apollo - for Active Hydraulic Option

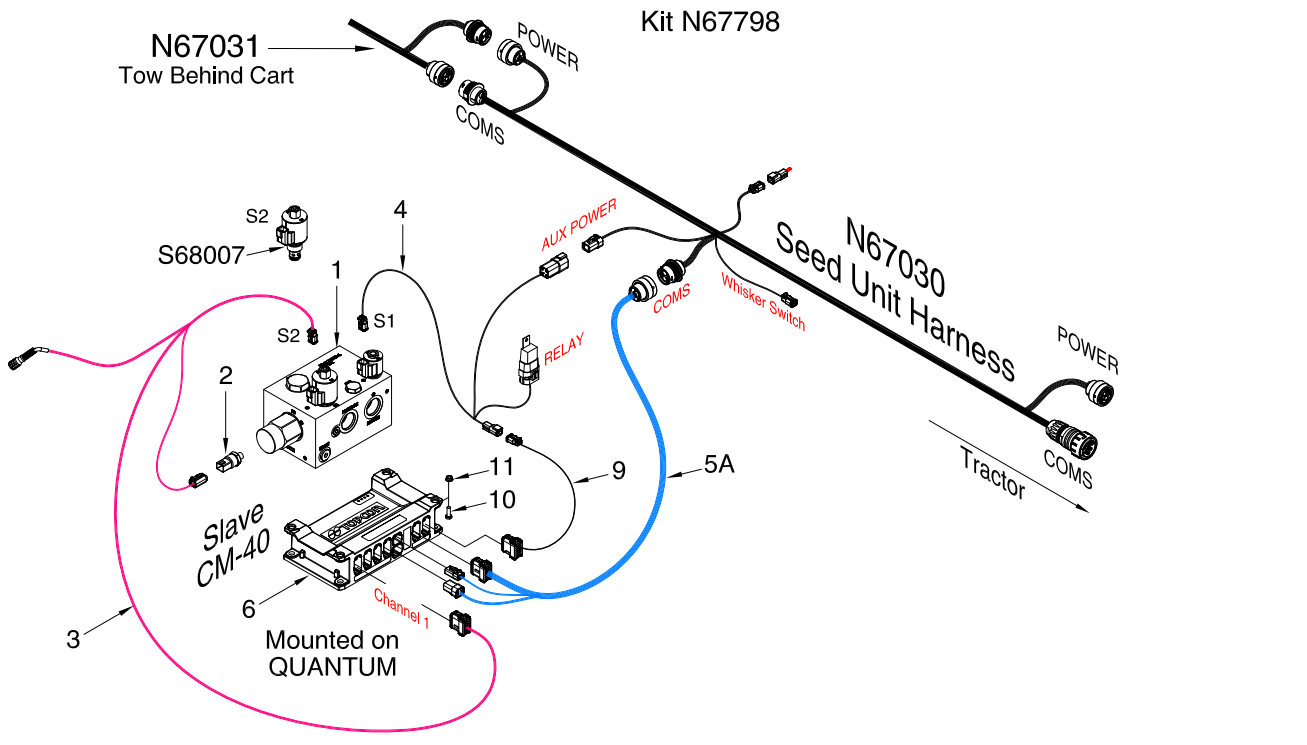
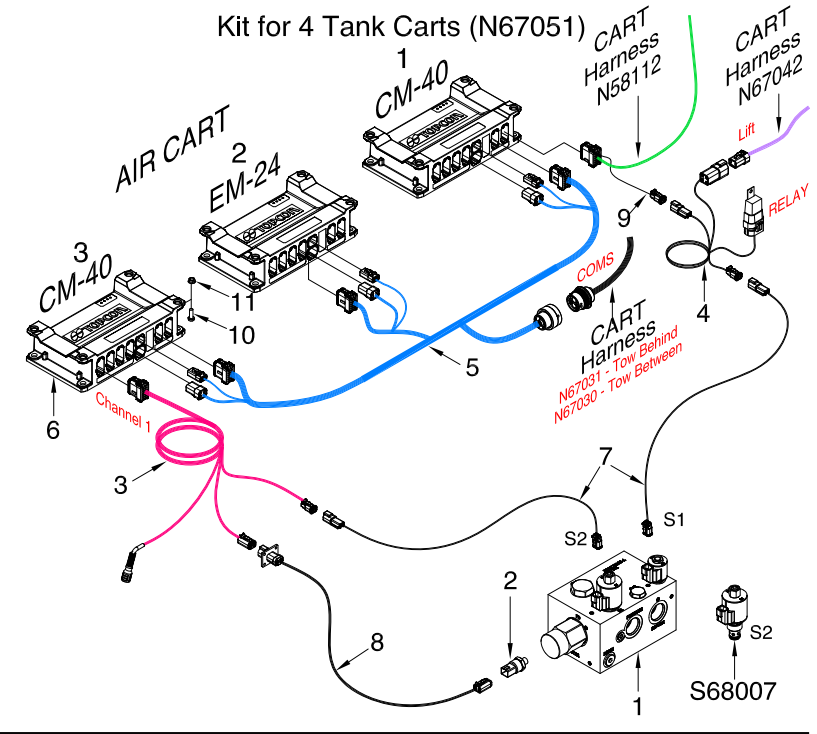
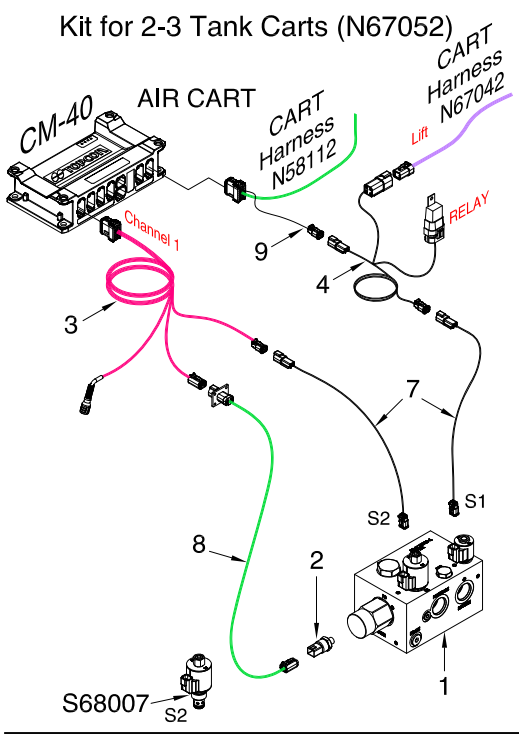

Apollo System - for Active Hydraulic Option

Item	Part No.	Description	Qty
1	S64940	Manifold - Opener Control - 3000 psi (Requires S68007 see note below)	1
	S68006	Manifold - Opener Control - 2000 psi (Includes S68007)	
2	K62977	Pressure Transducer	1
3	N67045	Harness - Pack Control (1026291-01)	1
4	N67046	Harness - Lift Control (1006258-01)	1
5	N67037	Harness - Triplex ECU Adapter (1005038-01)	1
5A	N67038	Harness - Single ECU (1005036-01)	1
5B	N68000	Harness Extension - 2m - (1028492-01) - Optional	
6	N68950	Apollo Master Module ECU - CM-40 Series 2 - (1024223-01)	1
7	N59010	Harness Extension - Work Switch - 5m - (AGA4468)	2
8	N64671	Pressure Transducer Extension Harness - 7m - (1024230-01)	1
9	N68001	AUX Lift Lower Signal Adapter	1
10	W-187	Hex Bolt - 3/8 x 1 1/4 Lg - Bolts ECU to plate under manifold	4
11	D-5279	Locknut - 3/8 Serrated Flange	4
	N67052	Lift and Pressure Control Kit for 2-3 Tank Carts (Includes Items 3, 4, 7 and 8)	
	N67051	Lift and Pressure Control Kit for 4 Tank Carts (Includes Items 3, 4, 5, 6, 7 and 8)	
	N67798	Lift and Pressure Control Kit for 4 Tank Carts Tow Behind ONLY (Includes Items 3, 4, 5A, 6, 9, 10 and 11)	
<p>Note: To operate the Apollo System , Manifold S64940 requires the S2 valve must be replaced with S68007 Valve Cartridge - TS12-36CM - 2000 psi</p>			

Pressure Control 10 Series Apollo - for Active Hydraulic Option

Tow Behind Configuration

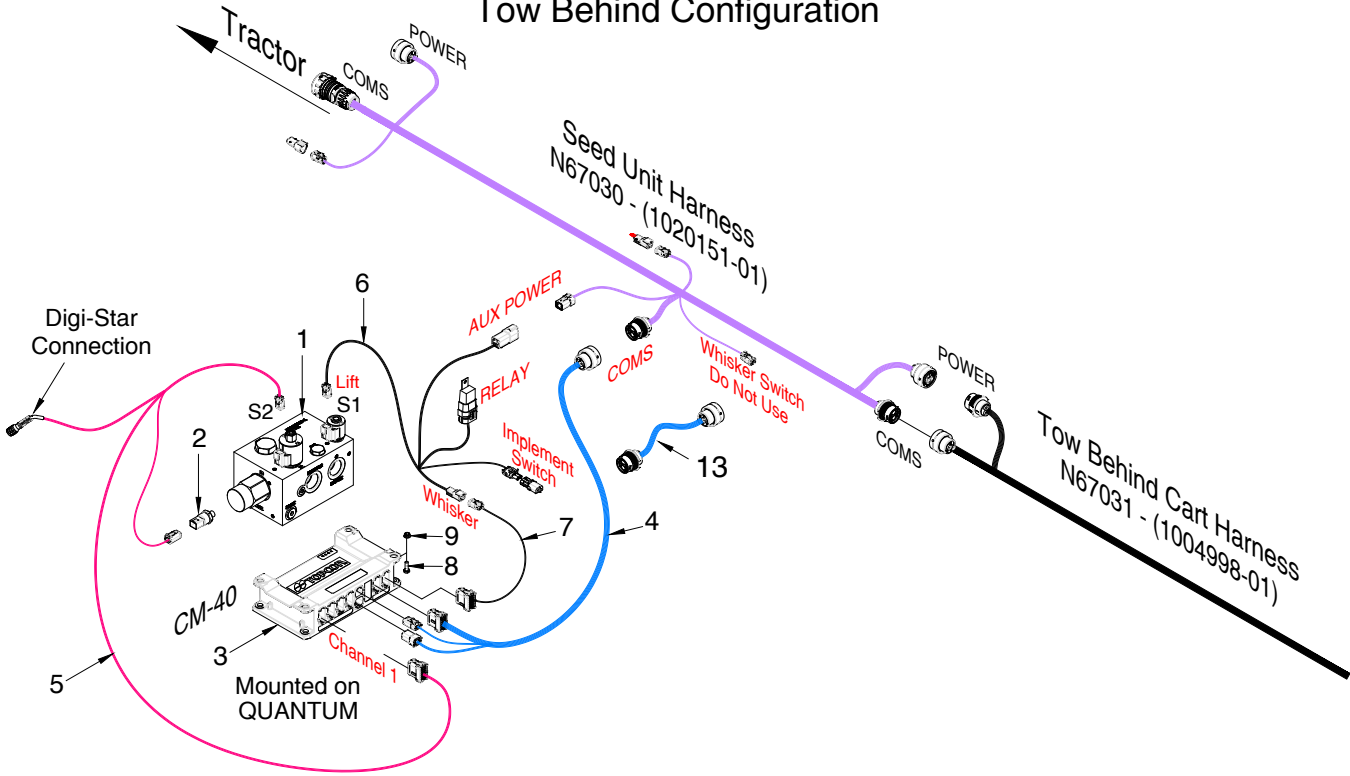

Tow Between Configuration

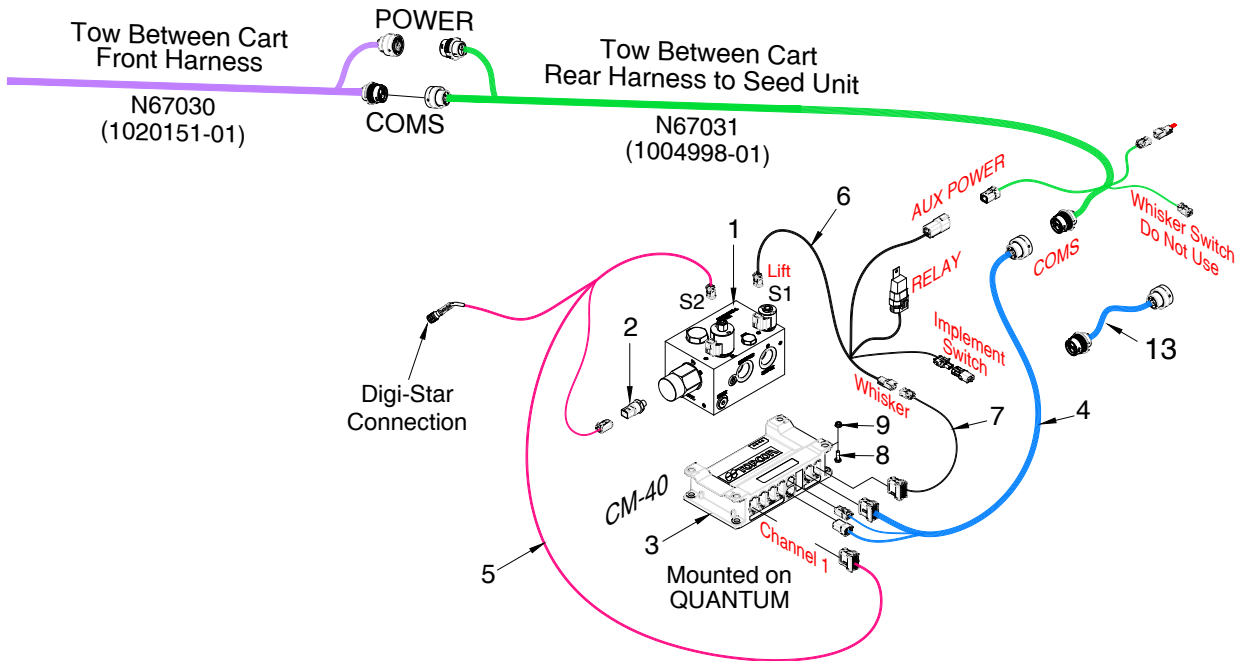

10 Series Apollo - for Active Hydraulic Option

Item	Part No.	Description	Qty
1	S68006	Manifold - Opener Control - 2000 psi (Includes S68007).....	1
2	K62977	Pressure Transducer	1
3	N74222	Apollo Master Module ECU - CM-40 - E-Drive Version (1069705-01).....	1
4	N67038	Harness - Single ECU (1005036-01).....	1
5	N67045	Harness - Pack Control (1026291-01)	1
6	N67046	Harness - Lift Control (1006258-01)	1
7	N68001	AUX Lift Lower Signal Adapter	1
8	W-187	Hex Bolt - 3/8 x 1 1/4 Lg - Bolts ECU to plate under manifold	4
9	D-5279	Locknut - 3/8 Serrated Flange.....	4
	N74270	Lift and Pressure Control Kit (Includes Items 3, 4, 5, 6, and 7)	

Notes

Section 5: Cylinders and Valves

Section Contents

Wing Lift	5-2
Opener Cylinder	5-8
Opener Valve Block - Standard	5-9
Opener Valve Block - High Speed	5-10
Wing Lift Valve Block	5-12

Hydraulic Cylinders Wing Lift

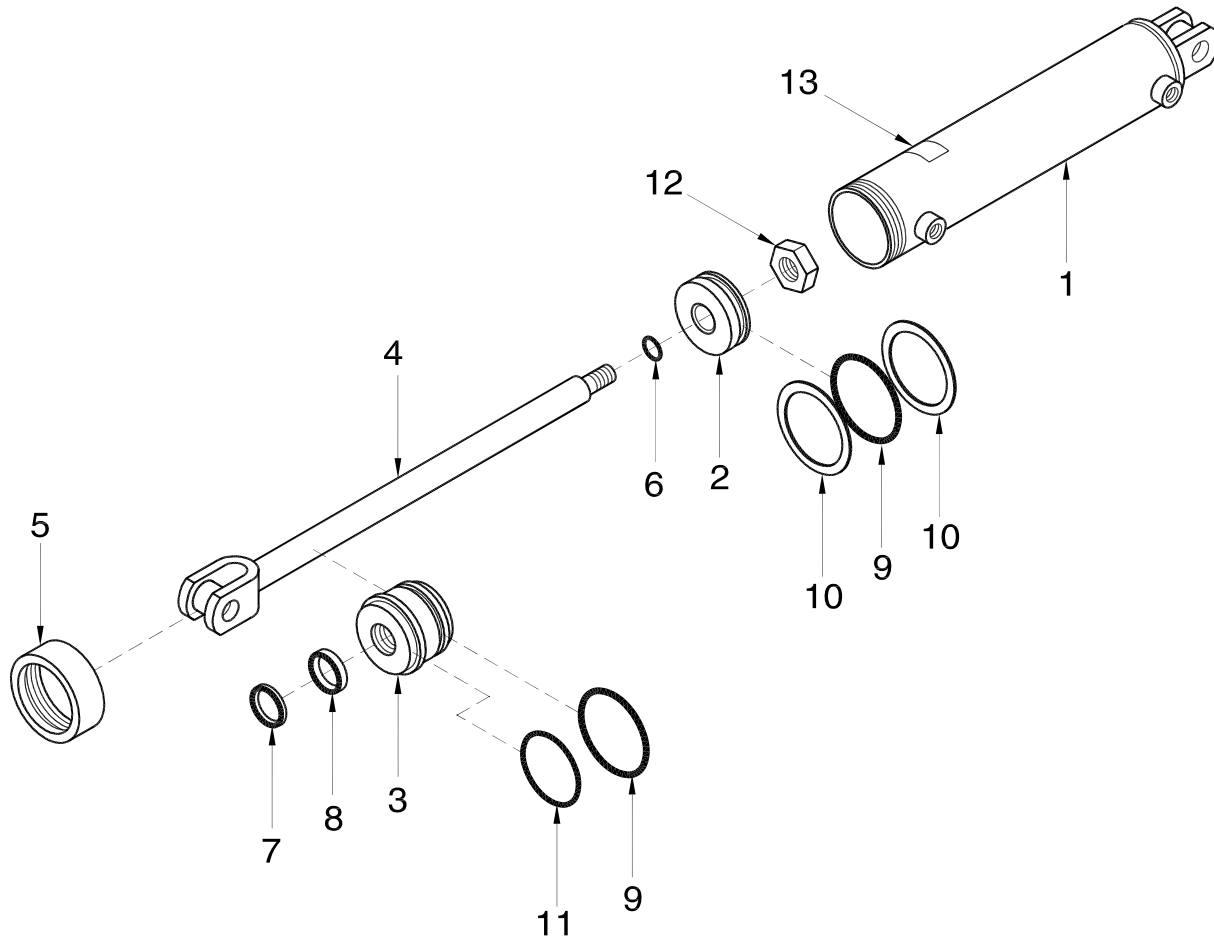

Item	Part No.	Description	Qty
		Wing Lift Cylinder - C26436 - 4 x 18	
1	C26437	Barrel - 4 x 18 ORB.....	1
2	C16637	Piston - 4 Dia - 7/8 Shaft.....	1
3	C-2026	Gland - 4 Dia - 1 1/4 Shaft.....	1
4	C32025	Cylinder Shaft - 1 1/4 Dia x 25 7/8.....	1
5	C-2023	Collar - 4 Cylinder.....	1
6	C-2187	1 OD x 1/16 C/S 90D BUNA O-Ring.....	1
7	C-2007	1 1/4 ID x 3/16 C/S 90D URTH Wiper.....	1
8	C-2008	1 1/4 ID x 5/16 C/S 90D URTH U-Cup.....	1
9	C-2030	4 OD x 3/16 C/S 90D BUNA O-Ring.....	2
10	C15386	Backup Washer - 4 Dia - #342.....	2
11	C-2215	3 7/8 OD x 1/16 C/S 70A BUNA-N O-Ring.....	1
12	C-2017	Locknut - 7/8 UNF Unitorque.....	1
13	C26846	Part # Plate for C26436.....	1
	C26436	Cylinder Assembly (Includes All Above Items)	
	C20449	Seal Kit (Includes Items #6, 7, 8, 9, 10 & 11)	

Hydraulic Cylinders Wing Lift

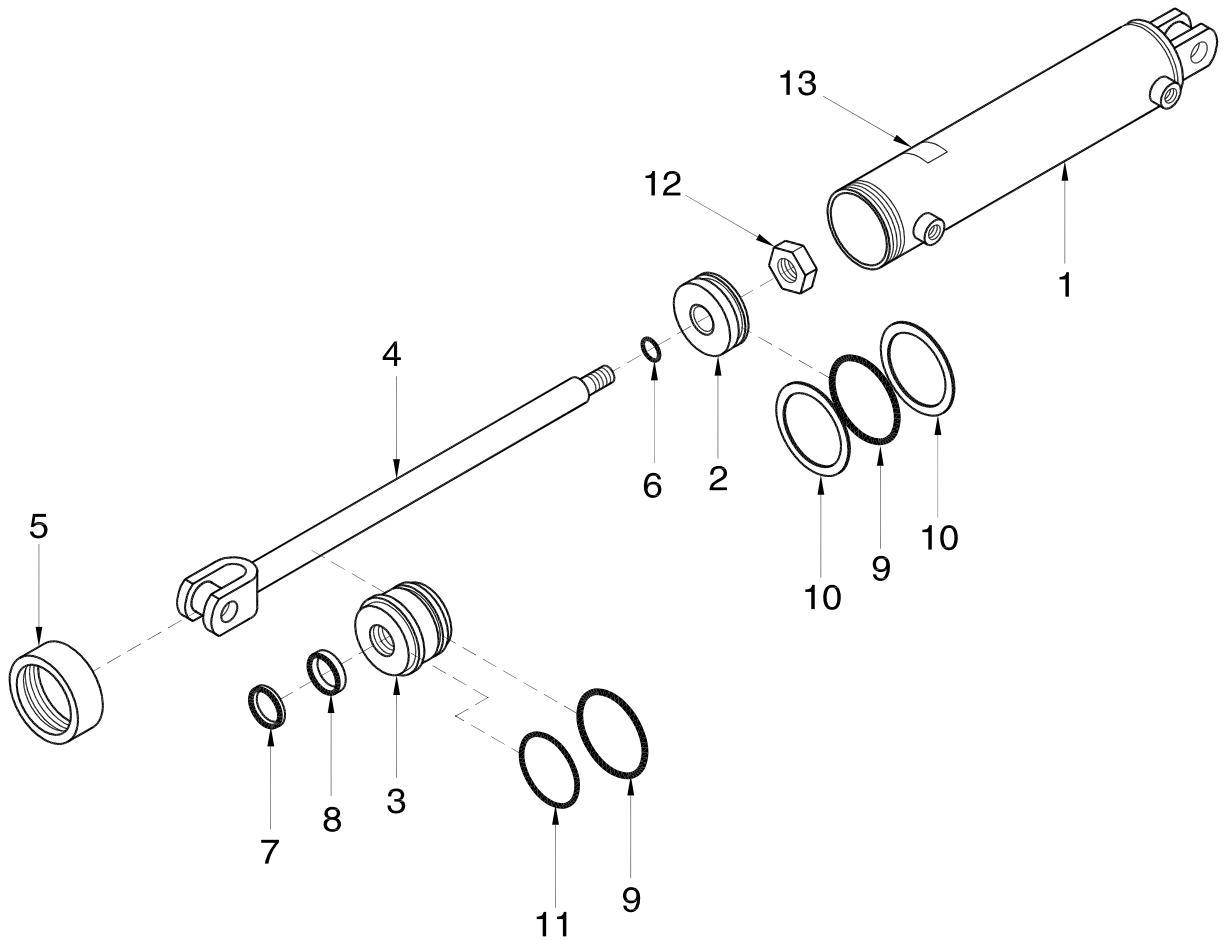

Item	Part No.	Description	Qty
		Wing Lift Cylinder - C34442 - 4 1/2 x 30	
1	C34441	Barrel - 4 1/2 x 30 - 1 1/4 clevis hole.....	1
2	C12836	Piston - 4 1/2 Dia - 1 Shaft.....	1
3	C-2154	Gland - 4 1/2 Dia - 1 3/4 Shaft	1
4	C26190	Cylinder Shaft - 1 3/4 Dia	1
5	C-2155	Collar - 4 1/2 Cylinder	1
6	C13282	1 1/8 OD x 1/16 C/S 90D BUNA O-Ring.....	1
7	C-2136	1 3/4 ID x 3/16 C/S 90D URTH Wiper.....	1
8	C-2135	1 3/4 ID x 3/8 C/S 90D URTH U-Cup.....	1
9	C-2164	4 1/2 OD x 3/16 C/S 90D BUNA O-Ring.....	2
10	C15387	Backup Washer - 4 1/2 Dia - #346	2
11	C-2215	3 7/8 OD x 1/16 C/S 70A BUNA-N O-Ring	1
12	C13763	Locknut - 1-14 UNS Uunitorque	1
13	C36064	Part # Plate for C34442.....	1
	C34442	Cylinder Assembly (Includes All Above Items)	
	C12849	Seal Kit (Includes Items #6, 7, 8, 9, 10 & 11)	

Hydraulic Cylinders Wing Lift

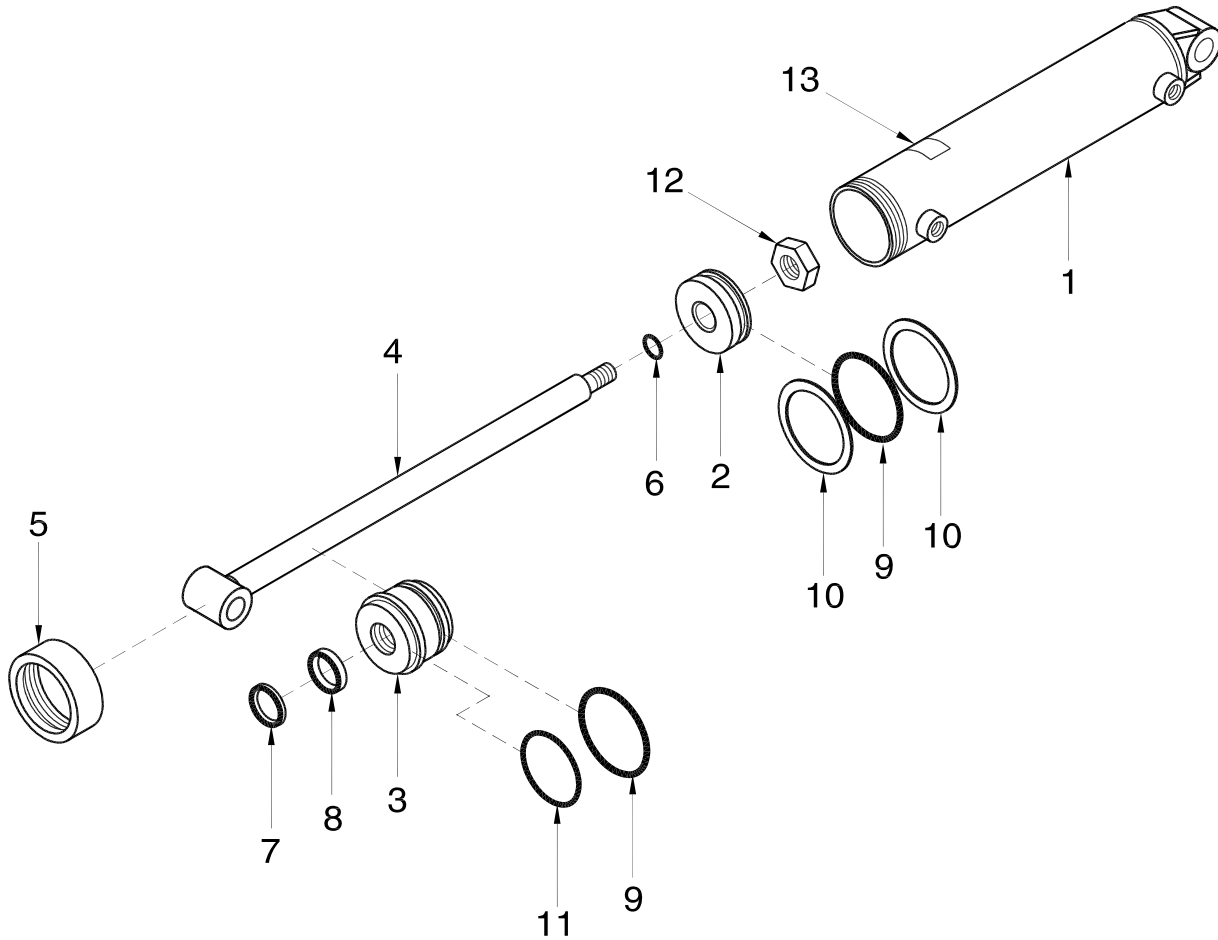

Item	Part No.	Description	Qty
Wing Lift Cylinder - C39030 - 4 1/2 x 36			
1	C39027	Barrel - 4 1/2 x 36 - 1 1/4 clevis hole.....	1
2	C12836	Piston - 4 1/2 Dia - 1 Shaft.....	1
3	C-2154	Gland - 4 1/2 Dia - 1 3/4 Shaft	1
4	C39029	Cylinder Shaft - 1 3/4 Dia.....	1
5	C-2155	Collar - 4 1/2 Cylinder	1
6	C13282	1 1/8 OD x 1/16 C/S 90D BUNA O-Ring.....	1
7	C-2136	1 3/4 ID x 3/16 C/S 90D URTH Wiper.....	1
8	C-2135	1 3/4 ID x 3/8 C/S 90D URTH U-Cup.....	1
9	C-2164	4 1/2 OD x 3/16 C/S 90D BUNA O-Ring.....	2
10	C15387	Backup Washer - 4 1/2 Dia - #346.....	2
11	C-2215	3 7/8 OD x 1/16 C/S 70A BUNA-N O-Ring	1
12	C13763	Locknut - 1-14 UNS Uunitorque	1
13	C39031	Part # Plate for C39030.....	1
	C39030	Cylinder Assembly (Includes All Above Items)	
	C12849	Seal Kit (Includes Items #6, 7, 8, 9, 10 & 11)	

Hydraulic Cylinders Wing Lift

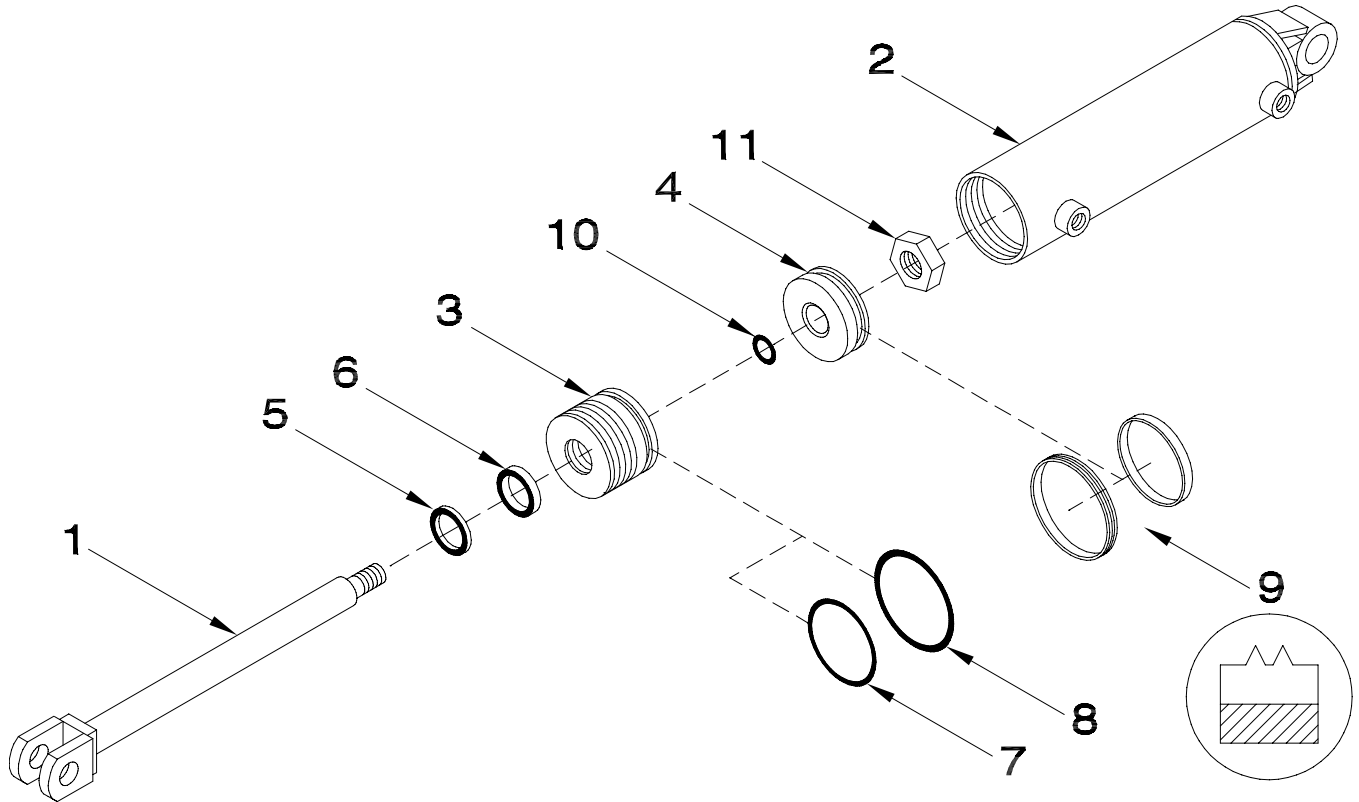

Item	Part No.	Description	Qty
		Wing Lift Cylinder - C47594 - 5 x 30	
1	C50179	Cylinder Shaft.....	1
2	C45675	Barrel - 5 x 30 ORB.....	1
3	C39916	Gland - 5 Dia.....	1
4	C39913	Piston - 5 Dia	1
5	C34598	Wiper.....	1
6	C34599	Shaft Seal.....	1
7	C39904	Backup Ring.....	1
8	C39900	Gland Seal (O-Ring)	1
9	C39892	Piston Seal - (PSP-A) (2 part seal)	1
10	C34592	Shaft Seal.....	1
11	C34596	Locknut	1
	C47594	Cylinder Assembly (Includes All Above Items)	
	C39906	Seal Kit (Includes Items #5, 6, 7, 8, 9 & 10)	

Hydraulic Cylinders Wing Lift

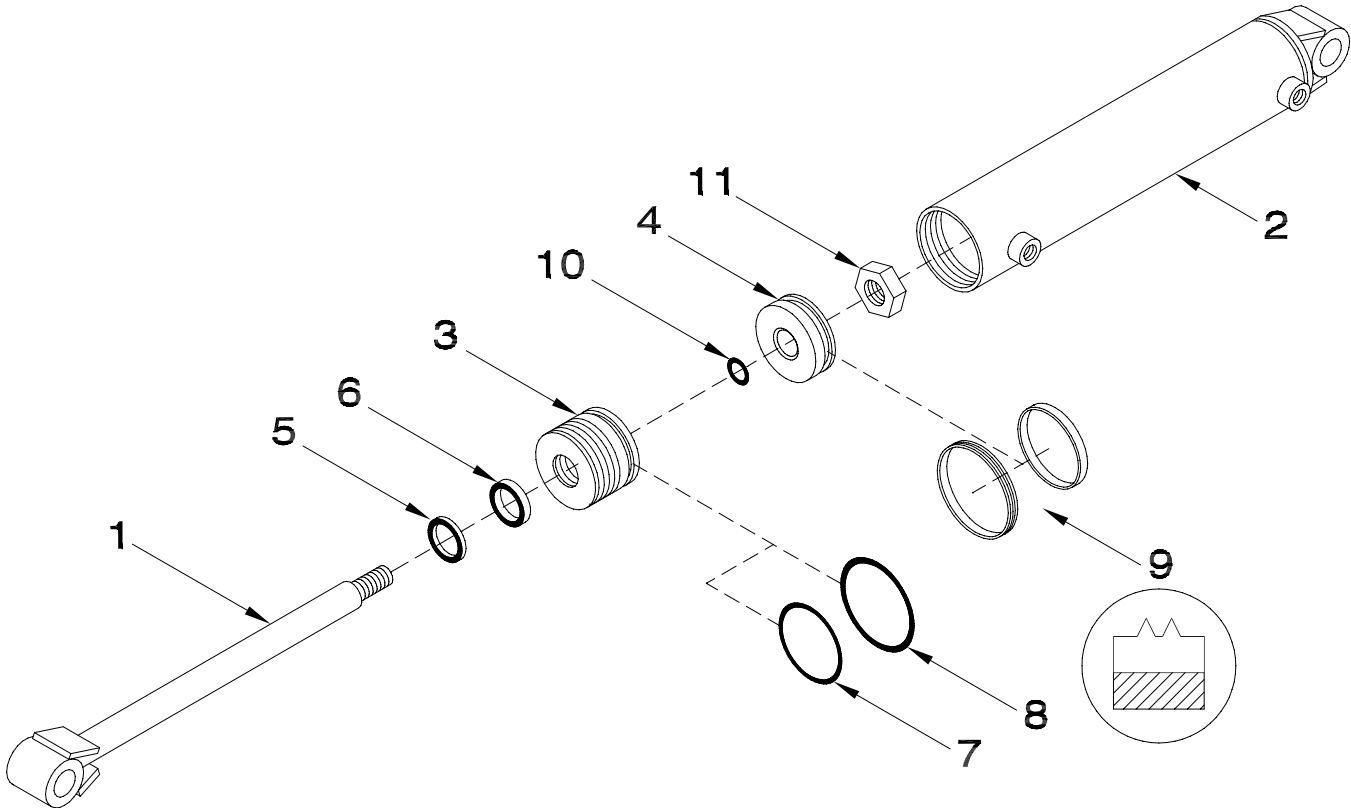

Item	Part No.	Description	Qty
Wing Lift Cylinder - C39490 - 5 x 36			
1	C39910	Cylinder Shaft.....	1
2	C39919	Barrel - 5 x 36 ORB.....	1
3	C39916	Gland - 5 Dia.....	1
4	C39913	Piston - 5 Dia	1
5	C34598	Wiper.....	1
6	C34599	Shaft Seal.....	1
7	C39904	Backup Ring.....	1
8	C39900	Gland Seal (O-Ring)	1
9	C39892	Piston Seal - (PSP-A) (2 part seal)	1
10	C34592	Shaft Seal.....	1
11	C34596	Locknut	1
	C39490	Cylinder Assembly (Includes All Above Items)	
	C39906	Seal Kit (Includes Items #5, 6, 7, 8, 9 & 10)	

Hydraulic Cylinders Wing Lift

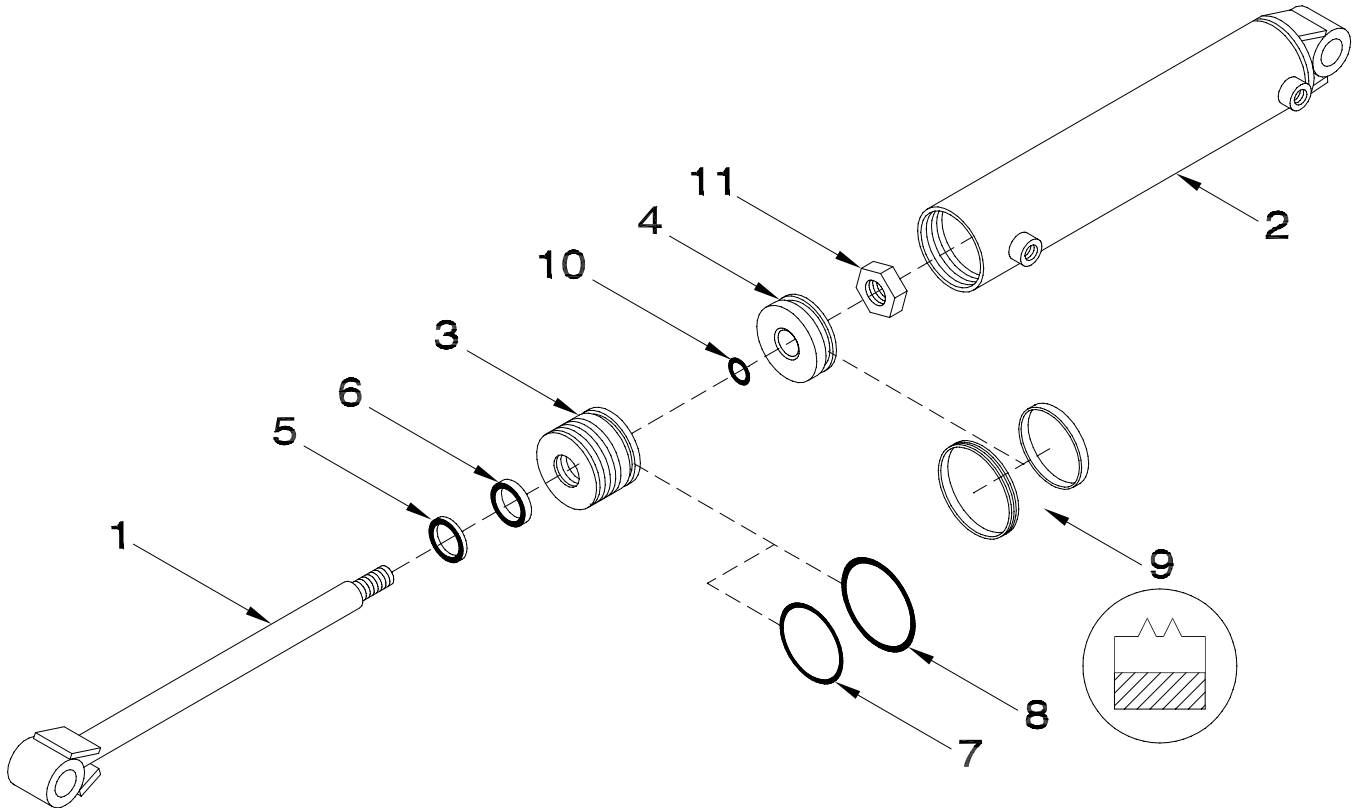

Item	Part No.	Description	Qty
		Wing Lift Cylinder - C53255 - 5 1/2 x 30	
		Wing Lift Cylinder - C53250 - 5 1/2 x 36	
1		Cylinder Shaft - 2 Dia x 30	1
1A		Cylinder Shaft - 2 Dia x 36	
2		Barrel - 5 1/2 x 30 ORB.....	1
2A		Barrel - 5 1/2 x 36 ORB	
3		Gland - 5 1/2 Dia.....	1
4		Piston - 5 1/2 Dia	1
5		Wiper.....	1
6		Shaft Seal.....	1
7		Backup Ring.....	1
8		Gland Seal (O-Ring)	1
9		Piston Seal - (PSP-A) (2 part seal)	1
10		Shaft Seal.....	1
11		Locknut	1
	C53255	Cylinder Assembly - 5 1/2 x 30	
	C53250	Cylinder Assembly - 5 1/2 x 36	
	C55803	Seal Kit (Includes Items #5, 6, 7, 8, 9 & 10)	

Hydraulic Cylinders Opener Cylinder

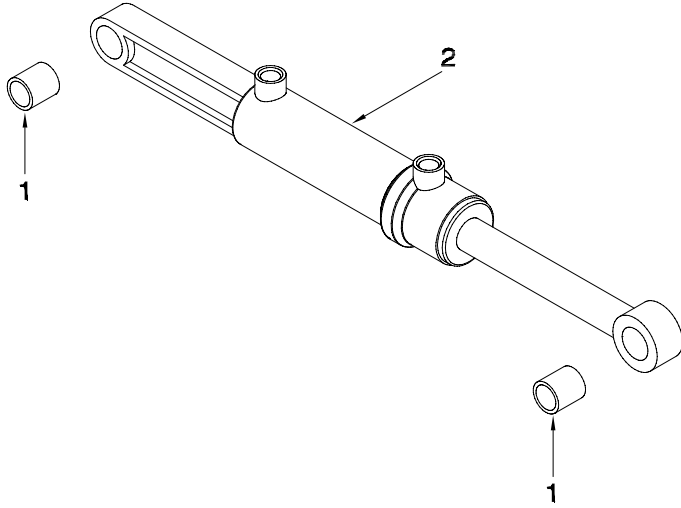

Opener Cylinder ID

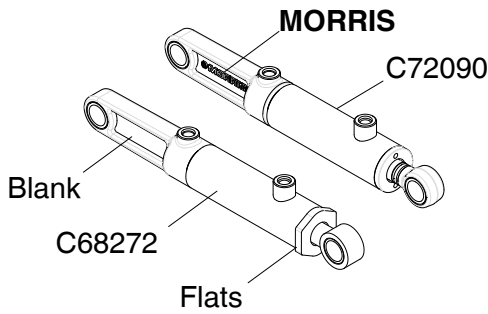

Monarch - C64546



Cylinder C68272



MORRIS

Cylinder C72090

Item	Part No.	Description	Qty
1	S51494	Opener Cylinder - C51033 - 1 3/4 x 4 - retracted length 20.94" - Prior to 2020 Bushing - 0.756/0.759 ID x 1.003/1.005 OD x 1.000 Lg.....	2
2	C51033	Cylinder Assembly (Includes All Above Items)	1
	C71900	Seal Kit	
1	S51494	Work Switch Cylinder - C51153 - 1 3/4 x 4 - retracted length 16.13" - Prior to 2014 Bushing - 0.756/0.759 ID x 1.003/1.005 OD x 1.000 Lg.....	2
2	C51153	Cylinder Assembly (Includes All Above Items)	1
	C71900	Seal Kit	
1	S72042	Opener Cylinder - C64546 - 1 3/4 x 4 - retracted length 14.8125" - 2020 to 2021 EWS Bushing - 1 ID x 1 1/8 OD x 1 Lg Nominal size	2
2	C64546	Cylinder Assembly (Includes All Above Items)	1
	C71900	Seal Kit	
1	S72046	Opener Cylinder - C68272 - 1 3/4 x 4 - retracted length 14.8125" - 2022 to 2024 EWS Bushing - 1 ID x 1 1/4 OD x 1 Lg Nominal size.....	2
2	C68272	Cylinder Assembly (Includes All Above Items)	1
	C71900	Seal Kit	
1	S72410	Opener Cylinder - C72090 - 1 3/4 x 4 - retracted length 14.75" - 2022 to Present Bushing - 1 ID x 1 1/4 OD x 1 Lg Nominal size	2
2	C68272	Cylinder Assembly (Includes All Above Items)	1
	C72720	Seal Kit	

Hydraulic Cylinders Opener Valve Block - Standard

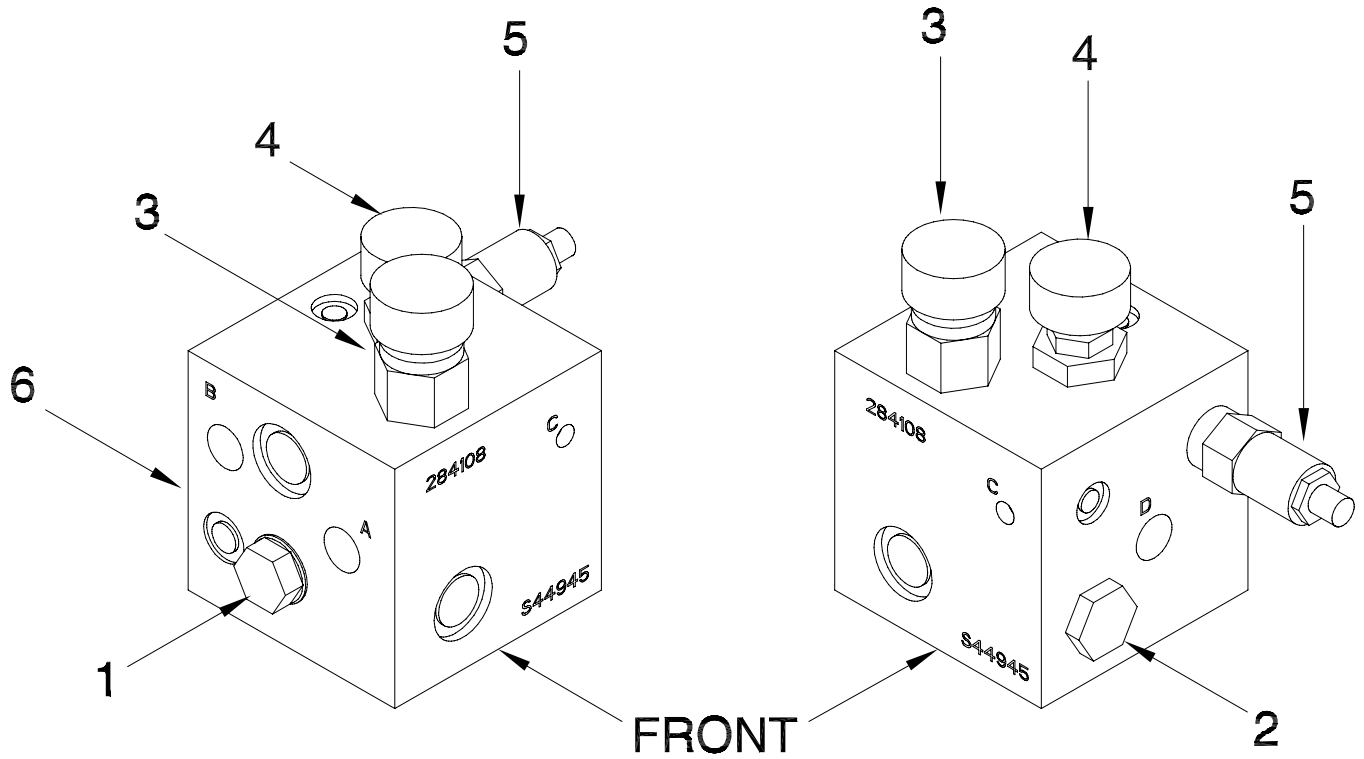

Item	Part No.	Description	Qty
1	S47139	Check Valve Cartridge - Pilot Operated.....	1
2	S47140	Check Valve Cartridge - Poppet	1
3	S47141	Check Valve Cartridge - Reducing/Relieving Valve.....	1
4	S47142	Cartridge Valve - Needle Valve	1
5	S47143	Cartridge - Pilot Operated - Accumulator Lock Out Valve.....	1
6	S44945	Hydraulic Down Pressure Manifold (Includes All Above Items)	

Hydraulic Cylinders Opener Valve Block - High Speed

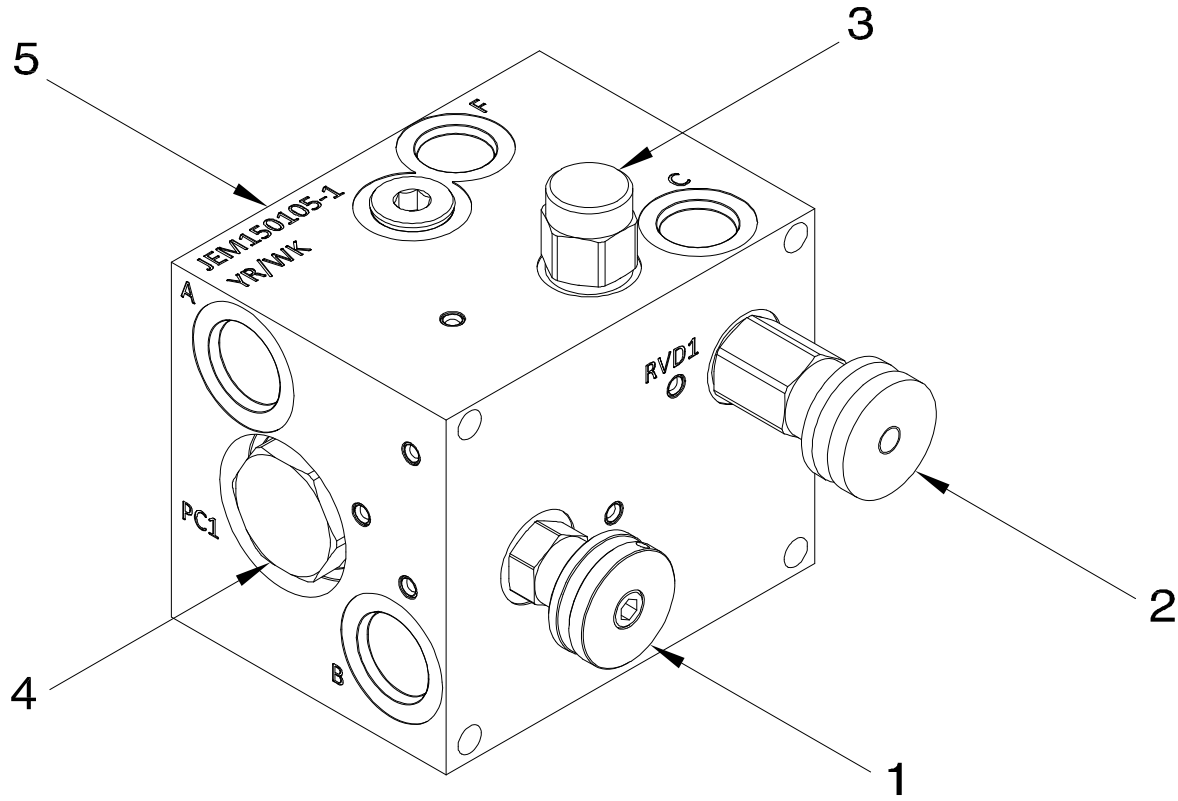

Item	Part No.	Description	Qty
1	S59842	Needle Valve (NV08-20B-0-N)	1
2	S59843	Relief Valve, Poppet Type (RVD50-20B-0-N-15)	1
3	S59844	Pilot Directional Valve (PD10-45-0-N-100)	1
4	S59846	Check Valve (CV16-20-0-N-S)	1
5	S58700	High Speed Manifold (Includes All Above Items)	

Hydraulic Cylinders Opener Valve Block - Active Hydraulics

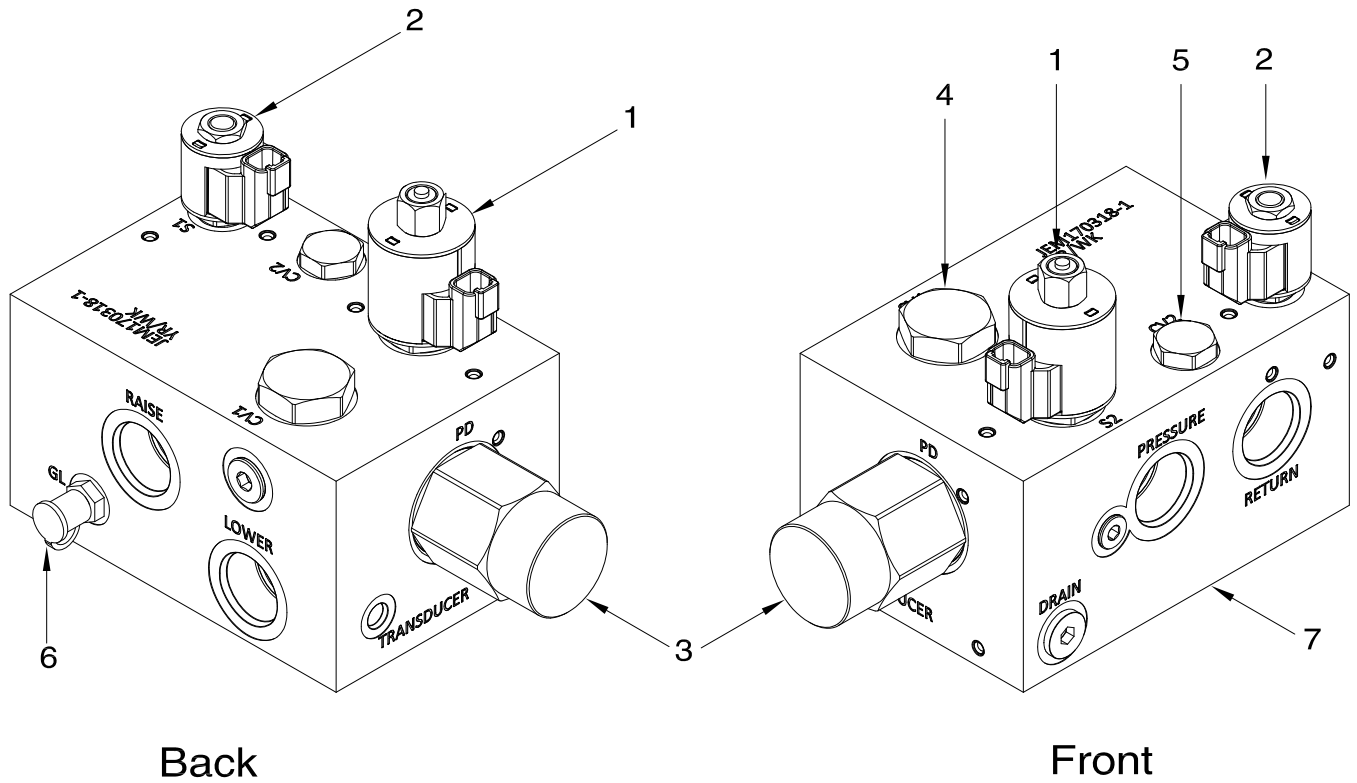

Item	Part No.	Description	Qty
1	S68008	Pressure Reducing/Relieving Proportional Valve - 2000 psi.....	1
	S68007	Valve ONLY - Pressure Reducing/Relieving Proportional Valve - 2000 psi	
2	S67317	Solenoid Valve.....	1
3	S67318	Pilot 4-Way. Valve.....	1
4	S67319	Check Valve - 5 psi.....	1
5	S67320	Check Valve - 2 psi.....	1
6	N64583	Coupler - Test Port - 7/16-20 (#4) MORB.....	1
7	S68006	Manifold - Opener Control - 2000 psi(Includes above Items).....	1

Hydraulic Cylinders Wing Lift Valve Block

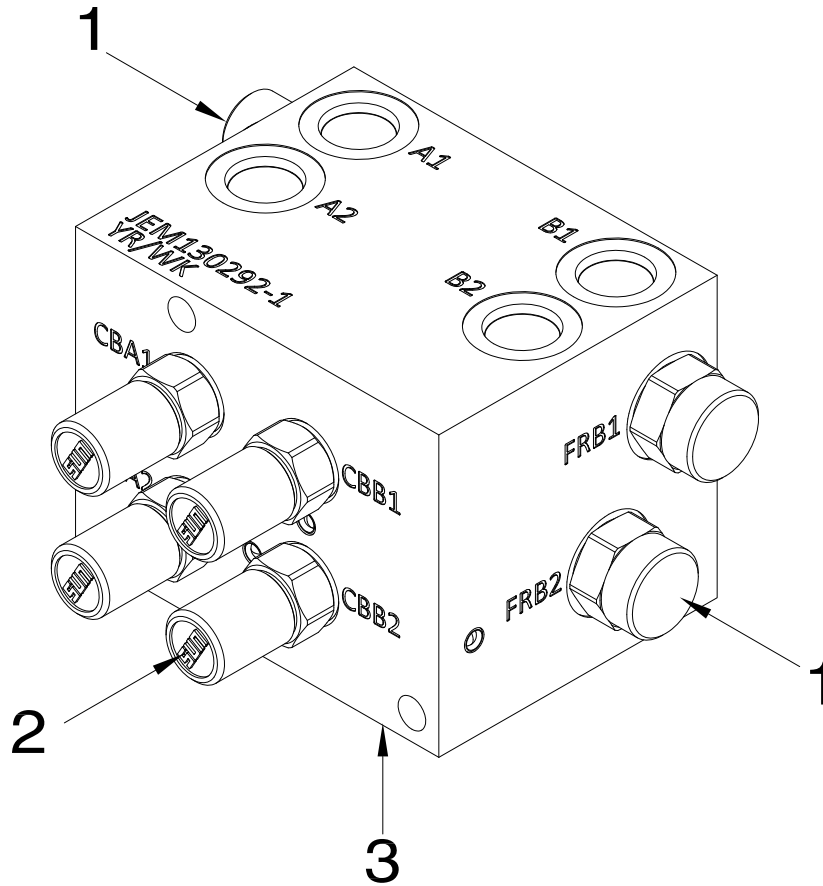

Item	Part No.	Description	Qty
1	C53847	Pressure Compensated Flow Control Cartridge - 5 gpm.....	4
2	C53848	Counterbalance Cartridge - 2700 psi	4
3	C53849	Counterbalance Winglift Manifold (Includes All Above Items)	

Section 6: Distribution - 8XL Series Carts

Section Contents

Single Shoot Tow Behind - 25 Ft and 31 Ft	6-2
Single Shoot Tow Behind - 41 to 51 ft.....	6-4
Single Shoot Tow Behind - 61 to 86 ft.....	6-6
Single Shoot Tow Between - 25 Ft and 31 Ft	6-8
Single Shoot Tow Between - 41 to 51 ft.....	6-10
Single Shoot Tow Between - 61 to 86 ft.....	6-12
Dual Shoot Tow Behind - 25 Ft and 31 Ft.....	6-14
Dual Shoot Tow Behind - 41 to 51 ft	6-16
Dual Shoot Tow Behind - 61 to 86 ft	6-18
Dual Shoot Tow Between - 25 Ft and 31 Ft.....	6-20
Dual Shoot Tow Between - 41 to 51 ft.....	6-22
Dual Shoot Tow Between - 61 to 86 ft.....	6-24

Distribution - 8XL Series Air Cart
 Single Shoot Tow Behind - 25 Ft and 31 Ft

8XL Series Air Cart Distribution

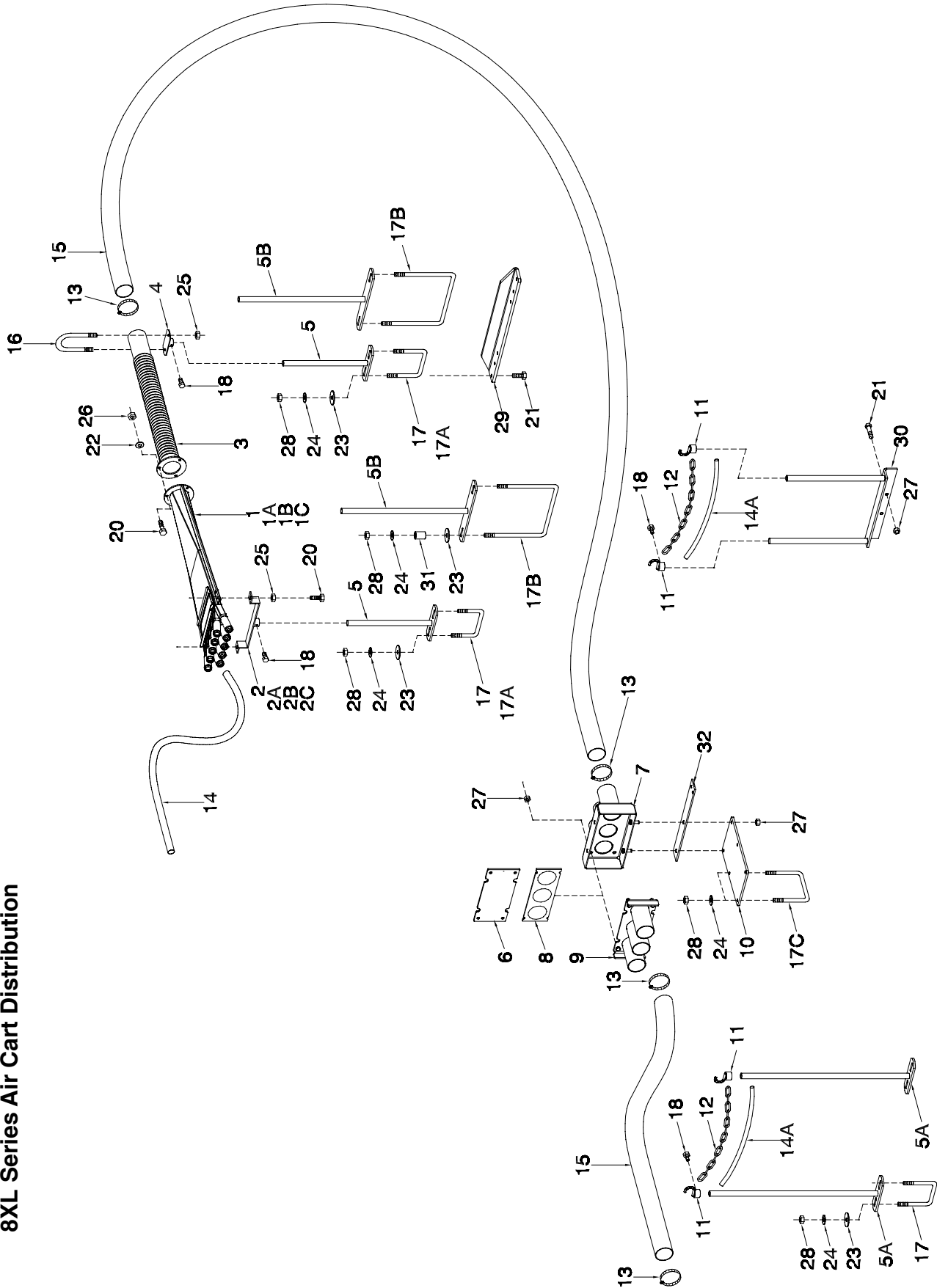

Distribution - Single Shoot Tow Behind - 25 Ft and 31 Ft

Item	Part No.	Description	No: Used			
			25 ft		31 ft	
			10	12	10	12
1	N42274	Divider Assembly - 11 Outlet	-	-	-	-
1A	N31190	Divider Assembly - 10 Outlet.....	-	-	-	-
1B	N31189	Divider Assembly - 9 Outlet.....	-	1	-	-
1C	N31188	Divider Assembly - 8 Outlet.....	2	2	1	3
1D	N31187	Divider Assembly - 7 Outlet.....	2	-	4	1
2	N40544	Support - 11 Outlet.....	-	-	-	-
2A	N19406	Support - 10 Outlet.....	-	-	-	-
2B	N15595	Support - 9 Outlet.....	-	1	-	-
2C	N15107	Support - 8 Outlet.....	2	2	1	3
2D	N15594	Support - 7 Outlet.....	2	-	4	1
3	N15135	Pipe - Corr Diff - Divider Head	4	3	5	4
4	N15102	Support - Rear	4	3	5	4
5	N15105	Support - Bottom - Rod 12"	8	4	8	8
5A	N19531	Support - Bottom - Rod 24"	2	2	2	2
5B	N45694	Support - Wide - Bottom - Rod 14"	-	2	2	-
6	N39876	Cover Plate - 3 Run.....	2	2	2	2
7	S39844	Coupler - 3 Run - Tillage	2	2	2	2
8	S39885	Gasket Seal - 3 Run.....	2	2	2	2
9	S39843	Coupler - 3 Run - Cart.....	2	2	2	2
10	S44463	Mount - Coupler	2	2	2	2
11	N19717	Hook - Chain	4	4	4	4
12	N19448	Chain - 80 Link.....	2	2	2	2
13	N11905	Hose Clamp - 2 1/2	16	12	20	16
14	R480034	Hose - .929 ID x 1.169 OD/ft (75 ft roll)	375	300	450	375
14A	R480034	Hose - .929 ID x 1.169 OD x 1.5 ft (75 ft roll)	2	2	2	2
15	R480055	Hose - 2 1/2 ID/ft (100 ft rolls)	75	50	100	75
16	N15096	U-Bolt - 1/4 x 2.5 x 3 1/4 lg	4	3	5	4
17	N15098	U-Bolt - 3/8 x 4 x 5	6	4	6	6
17A	N15097	U-Bolt - 3/8 x 2 x 5	4	4	4	4
17B	N40715	U-Bolt - 3/8 x 8 x 9 3/4	-	2	2	-
17C	N34025	U-Bolt - 3/8 x 5 x 8	4	4	4	4
18	N24396	Setscrew - 1/4 x 1/2	12	10	14	12
19	K-3830	Hex Bolt - 1/4 x 1/2 Lg	-	-	-	-
20	W-469	Hex Bolt - 1/4 x 3/4 Lg	20	18	25	20
21	W-187	Hex Bolt - 3/8 x 1 1/4 Lg	10	6	6	10
22	W-521	Lockwasher - 1/4	12	9	15	12
23	D-5579	Flatwasher - 3/8	36	16	36	36
24	W-523	Lockwasher - 3/8.....	36	16	36	36
25	D-5277	Serrated Locknut - 1/4.....	16	12	20	16
26	W-512	Hex Nut - 1/4	12	9	15	12
27	D-5279	Serrated Locknut - 3/8.....	14	14	14	14
28	W-514	Hex Nut - 3/8	36	16	36	36
29	S44308	Extension Bracket - Head Support.....	4	2	2	4
30	N45696	Hose Support.....	1	1	1	1
31	N11750	Bushing - 0.385 ID x 0.625 OD x 1 1/16 Lg	-	4	4	-
32	N45684	Bracket - Air Cart Hydraulic Quick Coupler Mount	1	1	1	1

Distribution - 8XL Series Air Cart Single Shoot Tow Behind - 41 to 51 ft

8XL Series Air Cart Distribution

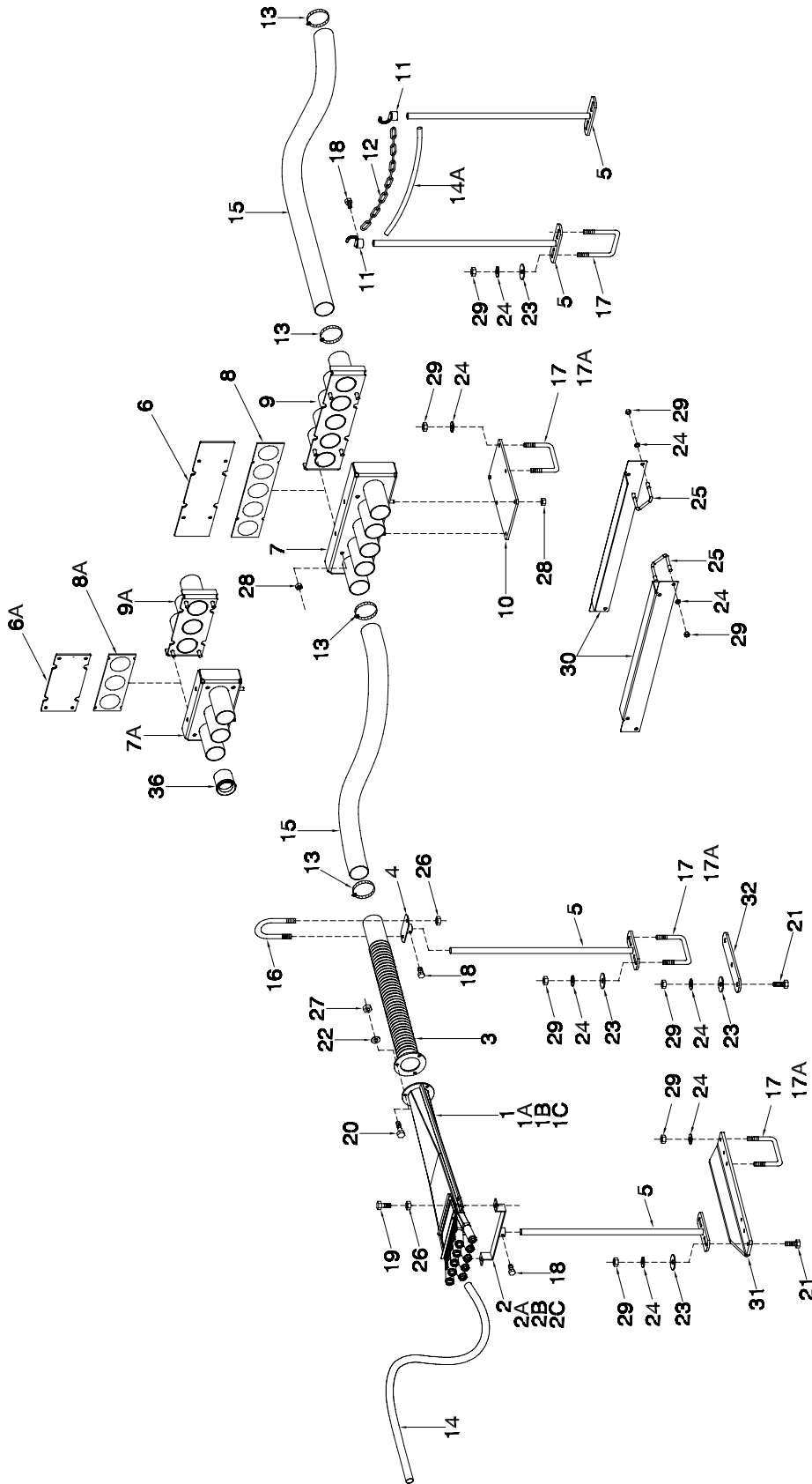

Distribution - Single Shoot Tow Behind - 41 to 51 ft

Item	Part No.	Description	No: Used			
			41 ft		51 ft	
			10	12	10	12
1	N42274	Divider Assembly - 11 Outlet	-	-	-	-
1A	N31190	Divider Assembly - 10 Outlet.....	-	-	-	-
1B	N31189	Divider Assembly - 9 Outlet.....	2	1	4	-
1C	N31188	Divider Assembly - 8 Outlet.....	4	4	3	2
1D	N31187	Divider Assembly - 7 Outlet.....	-	-	-	5
2	N40544	Support - 11 Outlet.....	-	-	-	-
2A	N19406	Support - 10 Outlet.....	2	-	-	-
2B	N15595	Support - 9 Outlet.....	4	1	4	-
2C	N15107	Support - 8 Outlet.....	-	4	3	2
2D	N15594	Support - 7 Outlet.....	-	-	-	5
3	N15135	Pipe - Corr Diff - Divider Head	6	5	7	7
4	N15102	Support - Rear	6	5	7	7
5	N19531	Support - Bottom - Rod 24".....	14	12	16	16
6	N39877	Cover Plate - 5 Run.....	0	0	4	4
6A	N39876	Cover Plate - 3 Run.....	4	4	0	0
7	S39743	Coupler - 5 Run - Tillage	0	0	2	2
7A	S39844	Coupler - 3 Run - Tillage	2	2	0	0
8	S39752	Gasket Seal - 5 Run.....	0	0	2	2
8A	S39885	Gasket Seal - 3 Run.....	2	2	0	0
9	S39747	Coupler - 5 Run - Cart.....	0	0	2	2
9A	S39843	Coupler - 3 Run - Cart	2	2	0	0
10	S44463	Mount - Coupler	2	2	2	2
11	N19717	Hook - Chain.....	2	2	2	2
12	N19448	Chain - 80 Link.....	1	1	1	1
13	N11905	Hose Clamp - 2 1/2	24	20	32	28
14	R480034	Hose - .929 ID x 1.169 OD/ft (75 ft roll)	450	375	600	600
14A	R480034	Hose - .929 ID x 1.169 OD/ft (75 ft roll)	1.5 ft	1.5 ft	1.5 ft	1.5 ft
15	R480055	Hose - 2 1/2 ID/ft (100 ft rolls)	125	100	75	75
16	N15096	U-Bolt - 1/4 x 2.5 x 3 1/4 lg	6	5	7	7
17	N15098	U-Bolt - 3/8 x 4 x 5	18	16	20	20
17A	N15097	U-Bolt - 3/8 x 2 x 5	14	12	16	16
18	N24396	Setscrew - 1/4 x 1/2	14	12	16	16
19	K-3830	Hex Bolt - 1/4 x 1/2 Lg.....	12	10	14	14
20	W-469	Hex Bolt - 1/4 x 3/4 Lg.....	18	15	21	21
21	W-187	Hex Bolt - 3/8 x 1 1/4 Lg.....	0	4	4	4
22	W-521	Lockwasher - 1/4.....	18	15	21	21
23	D-5579	Flatwasher - 3/8	28	24	32	32
24	W-523	Lockwasher - 3/8.....	52	52	60	60
25	D12714	U-Bolt - 3/8.....	8	8	8	8
26	D-5277	Serrated Locknut - 1/4.....	24	20	28	28
27	W-512	Hex Nut - 1/4	18	15	21	21
28	D-5279	Serrated Locknut - 3/8.....	12	12	12	12
29	W-514	Hex Nut - 3/8	52	52	60	60
30	S44307	Support Bracket - Distribution	4	4	4	4
31	S44308	Extension Bracket - Head Support.....	0	2	4	4
32	S44467	Head Support Plate	0	0	4	2

Distribution - 8XL Series Air Cart Single Shoot Tow Behind - 61 to 86 ft

8XL Series Air Cart Distribution

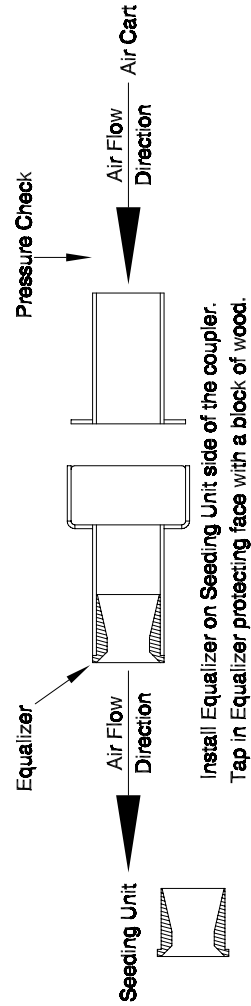
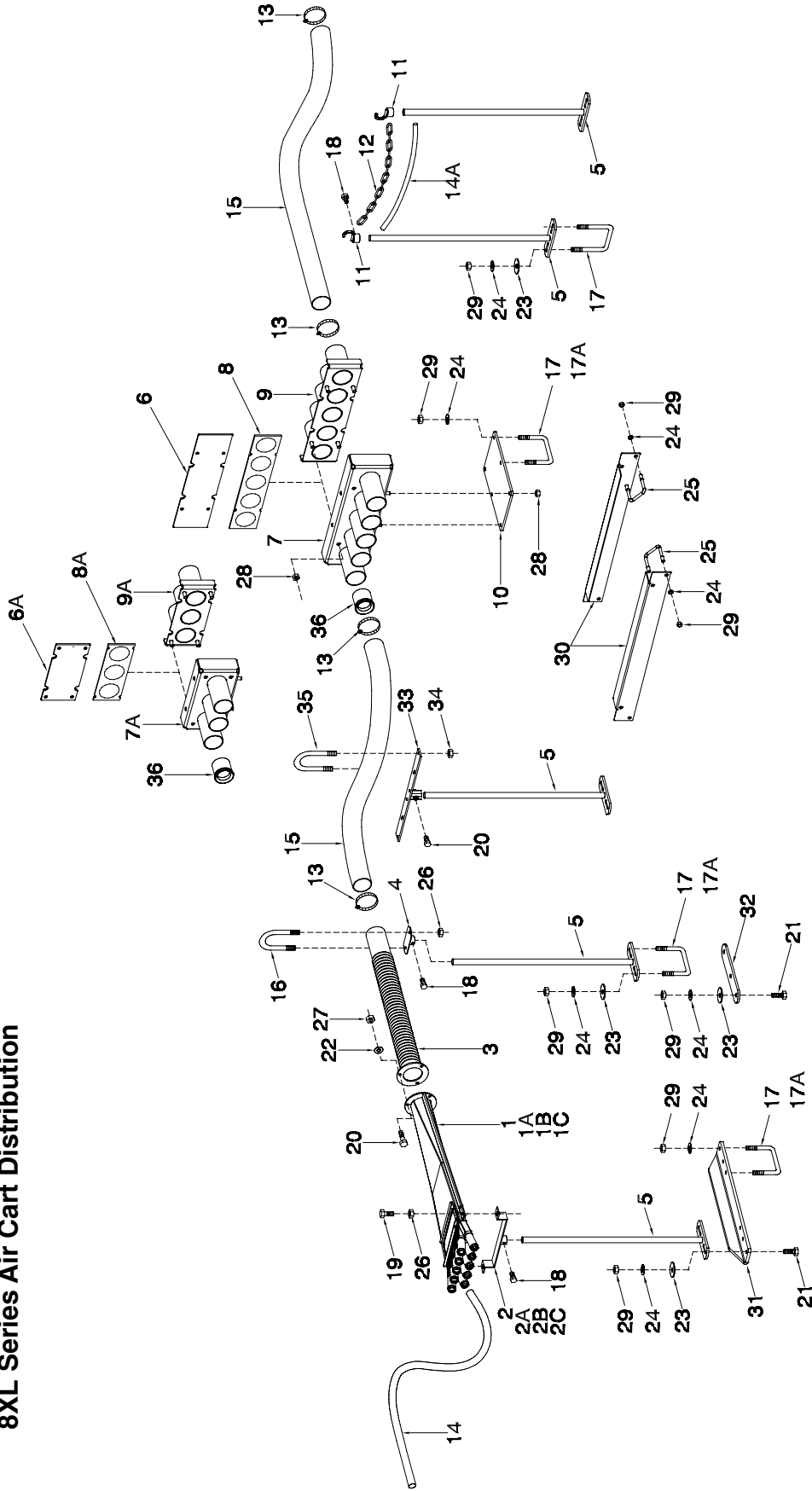

Distribution - Single Shoot Tow Behind - 61 to 86 ft

Item	Part No.	Description	No. Used							
			61 ft		71 ft		80 ft		86 ft	
			10	12	10	12	-	12	-	12
1	N42274	Divider Assembly - 11 Outlet	-	-	-	-	-	-	-	-
1A	N31190	Divider Assembly - 10 Outlet	-	-	3	-	-	-	-	5
1B	N31189	Divider Assembly - 9 Outlet	-	-	6	-	-	8	-	4
1C	N31188	Divider Assembly - 8 Outlet	9	5	-	8	-	1	-	-
1D	N31187	Divider Assembly - 7 Outlet	-	3	-	1	-	-	-	-
2	N40544	Support - 11 Outlet	-	-	-	-	-	-	-	-
2A	N19406	Support - 10 Outlet	-	-	3	-	-	-	-	5
2B	N15595	Support - 9 Outlet	-	-	6	-	-	8	-	4
2C	N15107	Support - 8 Outlet	9	5	-	8	-	1	-	-
2D	N15594	Support - 7 Outlet	-	3	-	1	-	-	-	-
3	N15135	Pipe - Corr Diff - Divider Head	9	8	9	9	-	9	-	9
4	N15102	Support - Rear	9	8	9	9	-	9	-	9
5	N19531	Support - Bottom - Rod 24"	20	18	20	20	-	20	-	20
6	N39877	Cover Plate - 5 Run	4	4	4	4	-	4	-	4
7	S39743	Coupler - 5 Run - Tillage	2	2	2	2	-	2	-	2
8	S39752	Gasket Seal - 5 Run	2	2	2	2	-	2	-	2
9	S39747	Coupler - 5 Run - Cart	2	2	2	2	-	2	-	2
10	S44463	Mount - Coupler	2	2	2	2	-	2	-	2
11	N19717	Hook - Chain	2	2	2	2	-	2	-	2
12	N19448	Chain - 80 Link	1	1	1	1	-	1	-	1
13	N11905	Hose Clamp - 2 1/2	36	32	36	36	-	36	-	36
14	R480034	Hose - .929 ID x 1.169 OD/ft (75 ft roll) ..	600	525	675	675	-	825	-	825
14A	R480034	Hose - .929 ID x 1.169 OD/ft (75 ft roll) ..	1.5 ft	1.5 ft	1.5 ft	1.5 ft	-	1.5 ft	-	1.5 ft
15	R480055	Hose - 2 1/2 ID/ft (100 ft rolls)	200	175	250	250	-	275	-	275
16	N15096	U-Bolt - 1/4 x 2.5 x 3 1/4 lg	9	8	9	9	-	9	-	9
17	N15098	U-Bolt - 3/8 x 4 x 5	24	22	24	24	-	24	-	24
17A	N15097	U-Bolt - 3/8 x 2 x 5	20	18	20	20	-	20	-	20
18	N24396	Setscrew - 1/4 x 1/2	20	18	20	20	-	20	-	20
19	K-3830	Hex Bolt - 1/4 x 1/2 Lg	18	16	18	18	-	18	-	18
20	W-469	Hex Bolt - 1/4 x 3/4 Lg	27	24	27	27	-	27	-	27
21	W-187	Hex Bolt - 3/8 x 1 1/4 Lg	15	6	15	15	-	15	-	15
22	W-521	Lockwasher - 1/4	27	24	27	27	-	27	-	27
23	D-5579	Flatwasher - 3/8	40	36	40	40	-	40	-	40
24	W-523	Lockwasher - 3/8	79	66	79	79	-	79	-	79
25	D12714	U-Bolt - 3/8	8	8	8	8	-	8	-	8
26	D-5277	Serrated Locknut - 1/4	36	32	36	36	-	36	-	36
27	W-512	Hex Nut - 1/4	27	24	27	27	-	27	-	27
28	D-5279	Serrated Locknut - 3/8	12	12	12	12	-	12	-	12
29	W-514	Hex Nut - 3/8	79	66	79	79	-	79	-	79
30	S44307	Support Bracket - Distribution	4	4	4	4	-	4	-	4
31	S44308	Extension Bracket - Head Support	2	4	7	7	-	7	-	7
32	S44467	Head Support Plate	0	0	1	1	-	1	-	1
33	N48297	Hose Support - 80 & 86	0	0	0	0	-	2	-	2
34	N22778	Locknut - 1/4 nylon insert	0	0	0	0	-	16	-	16
35	N37630	U-Bolt - 1/4 x 2 3/4 x 3 3/4	0	0	0	0	-	8	-	8
36	N37920	Equalizer	5	5	3	3	-	5	-	5

**Distribution - 8XL Series Air Cart
Single Shot Tow Between - 25 Ft and 31 Ft**

8XL Series Air Cart Distribution

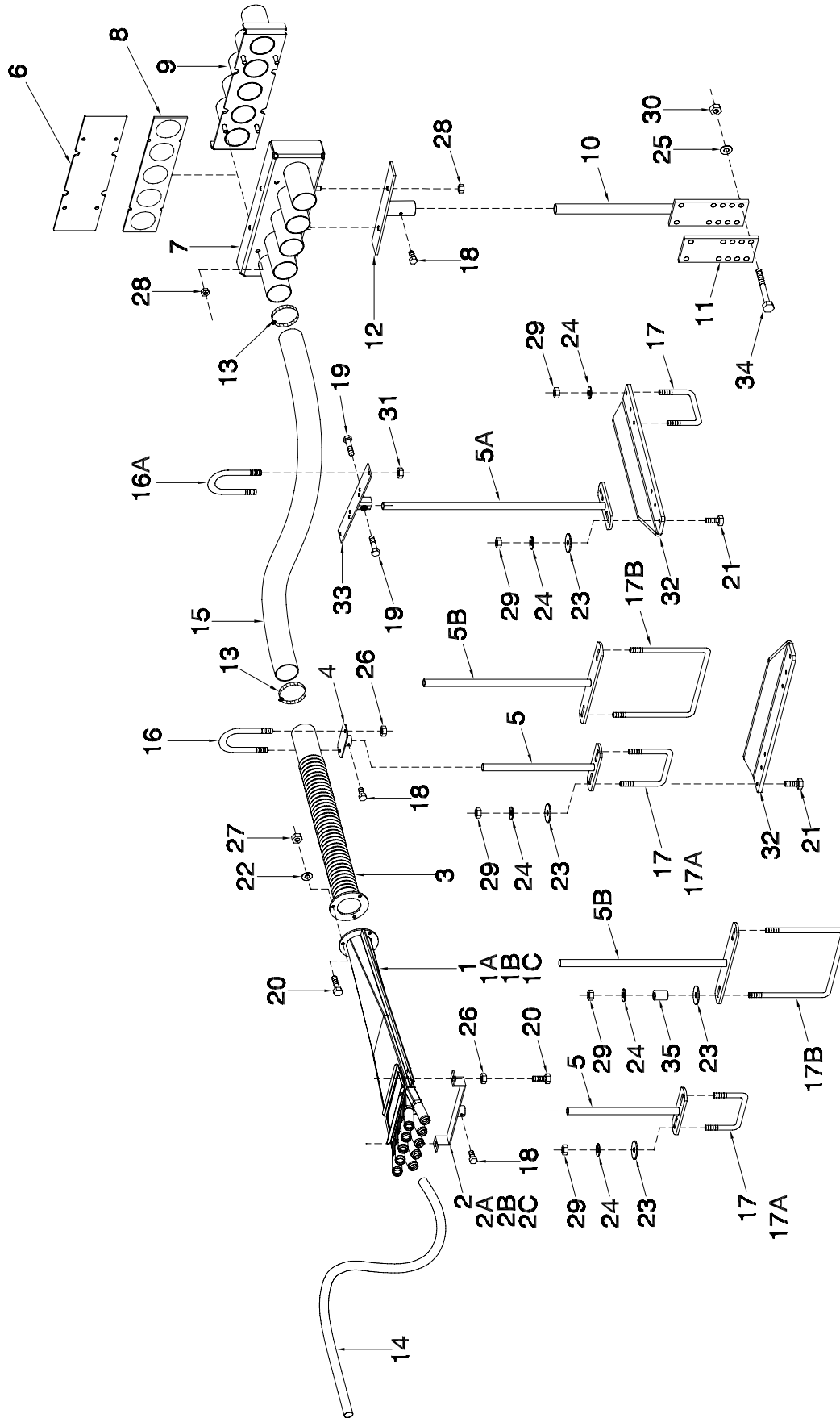

Distribtion - Single Shoot Tow Between - 25 Ft and 31 Ft

Item	Part No.	Description	No: Used			
			25 ft		31 ft	
			10	12	10	12
1	N42274	Divider Assembly - 11 Outlet	-	-	-	-
1A	N31190	Divider Assembly - 10 Outlet.....	-	-	-	-
1B	N31189	Divider Assembly - 9 Outlet.....	-	1	-	-
1C	N31188	Divider Assembly - 8 Outlet.....	2	2	1	3
1D	N31187	Divider Assembly - 7 Outlet.....	2	-	4	1
2	N40544	Support - 11 Outlet.....	-	-	-	-
2A	N19406	Support - 10 Outlet.....	-	-	-	-
2B	N15595	Support - 9 Outlet.....	-	1	-	-
2C	N15107	Support - 8 Outlet.....	2	2	1	3
2D	N15594	Support - 7 Outlet.....	2	-	4	1
3	N15135	Pipe - Corr Diff - Divider Head	4	3	5	4
4	N15102	Support - Rear	4	3	5	4
5	N15105	Support - Bottom - Rod 12"	8	4	8	8
5A	N19531	Support - Bottom - Rod 24"	2	2	2	2
5B	N45694	Support - Wide - Bottom - Rod 14"	-	2	2	-
6	N39877	Cover Plate - 5 Run.....	1	1	1	1
7	S39743	Coupler - 5 Run - Tillage	1	1	1	1
8	S39752	Gasket Seal - 5 Run	1	1	1	1
9	S39747	Coupler - 5 Run - Cart	1	1	1	1
10	N19575	Base - Hose Coupler.....	1	1	1	1
11	N19409	Plate - Mount.....	1	1	1	1
12	N39840	Mount - Coupler	1	1	1	1
13	N11905	Hose Clamp - 2 1/2.....	16	12	20	16
14	R480034	Hose - .929 ID x 1.169 OD/ft (75 ft roll)	375	300	450	375
15	R480055	Hose - 2 1/2 ID/ft (100 ft rolls)	75	50	100	75
16	N15096	U-Bolt - 1/4 x 2.5 x 3 1/4 lg	4	3	5	4
16A	N37630	U-Bolt - 1/4 x 2 3/4 x 3 3/4 Lg	4	2	4	4
17	N15098	U-Bolt - 3/8 x 4 x 5	6	4	6	6
17A	N15097	U-Bolt - 3/8 x 2 x 5	4	2	4	4
17B	N40715	U-Bolt - 3/8 x 8 x 9 3/4	-	2	2	-
18	N24396	Setscrew - 1/4 x 1/2	10	8	12	10
19	K-3830	Hex Bolt - 1/4 x 1/2 Lg	4	4	4	4
20	W-469	Hex Bolt - 1/4 x 3/4 Lg	20	15	25	20
21	W-187	Hex Bolt - 3/8 x 1 1/4 Lg	8	4	4	8
22	W-521	Lockwasher - 1/4	12	9	15	12
23	D-5579	Flatwasher - 3/8	20	16	24	20
24	W-523	Lockwasher - 3/8.....	28	24	28	28
25	W-525	Lockwasher - 1/2.....	4	4	4	4
26	D-5277	Serrated Locknut - 1/4.....	16	12	20	16
27	W-512	Hex Nut - 1/4	12	9	15	12
28	D-5279	Serrated Locknut - 3/8.....	6	6	6	6
29	W-514	Hex Nut - 3/8	28	20	28	28
30	W-516	Hex Nut - 1/2	4	4	4	4
31	N22778	Locknut Nylon Insert - 1/4	8	8	8	8
32	S44308	Extension Bracket - Head Support.....	4	2	2	4
33	N40704	Support - Hose.....	2	2	2	2
34	S-951	Hex Bolt - 1/2 x 4 1/2 Lg.....	4	4	4	4
35	N11750	Bushing - 0.385 ID x 0.625 OD x 1 1/16 Lg	-	4	4	-

Distribution - 8XL Series Air Cart Single Shoot Tow Between - 41 to 51 ft

8XL Series Air Cart Distribution

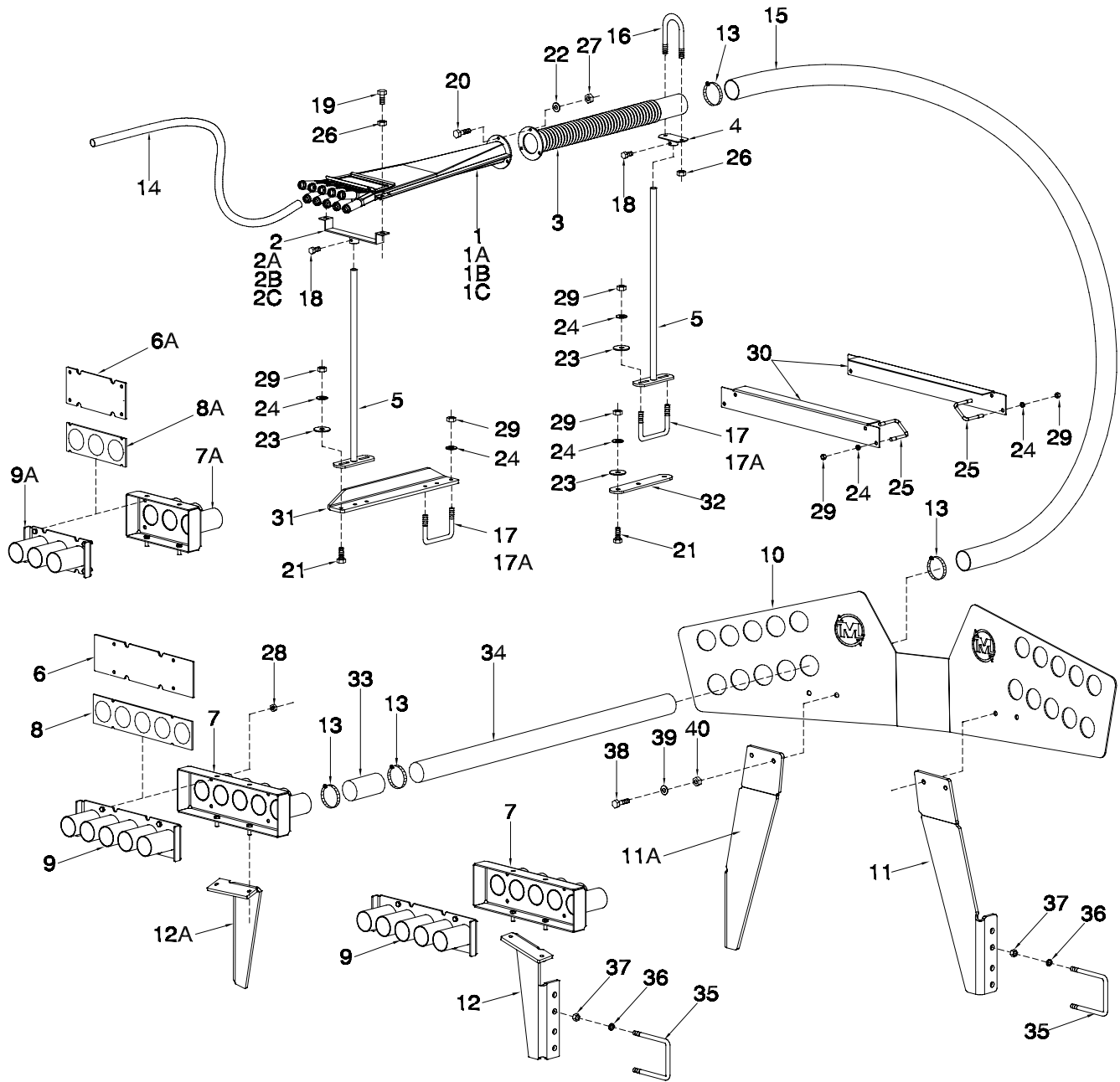

Distribtion - Single Shoot Tow Between - 41 to 51 ft

Item	Part No.	Description	No: Used			
			41 ft		51 ft	
			10	12	10	12
1	N42274	Divider Assembly - 11 Outlet	-	-	-	-
1A	N31190	Divider Assembly - 10 Outlet.....	-	-	-	-
1B	N31189	Divider Assembly - 9 Outlet.....	2	1	4	-
1C	N31188	Divider Assembly - 8 Outlet.....	4	4	3	2
1D	N31187	Divider Assembly - 7 Outlet.....	-	-	-	5
2	N40544	Support - 11 Outlet.....	-	-	-	-
2A	N19406	Support - 10 Outlet.....	2	-	-	-
2B	N15595	Support - 9 Outlet.....	4	1	4	-
2C	N15107	Support - 8 Outlet.....	-	4	3	2
2D	N15594	Support - 7 Outlet.....	-	-	-	5
3	N15135	Pipe - Corr Diff - Divider Head	6	5	7	7
4	N15102	Support - Rear	6	5	7	7
5	N19531	Support - Bottom - Rod 24".....	14	12	16	16
6	N39877	Cover Plate - 5 Run.....	0	0	2	2
6A	N39876	Cover Plate - 3 Run.....	4	4	0	0
7	S39743	Coupler - 5 Run - Tillage	0	0	2	2
7A	S39844	Coupler - 3 Run - Tillage	2	2	0	0
8	S39752	Gasket Seal - 5 Run.....	0	0	2	2
8A	S39885	Gasket Seal - 3 Run.....	2	2	0	0
9	S39747	Coupler - 5 Run - Cart.....	0	0	2	2
9A	S39843	Coupler - 3 Run - Cart	2	2	0	0
10	S39336	Carrier Plate - Distribution.....	1	1	1	1
11	S45821	Plate - Left.....	1	1	1	1
11A	S45822	Plate - Right	1	1	1	1
12	S45823	Plate - Left.....	1	1	1	1
12A	S45824	Plate - Right	1	1	1	1
13	N11905	Hose Clamp - 2 1/2	24	20	28	28
14	R480034	Hose - .929 ID x 1.169 OD/ft (75 ft roll)	450	375	600	600
15	R480055	Hose - 2 1/2 ID/ft (100 ft rolls)	125	100	100	100
16	N15096	U-Bolt - 1/4 x 2.5 x 3 1/4 lg	6	5	7	7
17	N15098	U-Bolt - 3/8 x 4 x 5	18	16	20	20
17A	N15097	U-Bolt - 3/8 x 2 x 5	14	12	16	16
18	N24396	Setscrew - 1/4 x 1/2	14	12	16	16
19	K-3830	Hex Bolt - 1/4 x 1/2 Lg.....	12	10	14	14
20	W-469	Hex Bolt - 1/4 x 3/4 Lg.....	18	15	21	21
21	W-187	Hex Bolt - 3/8 x 1 1/4 Lg.....	0	4	4	4
22	W-521	Lockwasher - 1/4.....	18	15	21	21
23	D-5579	Flatwasher - 3/8	28	24	32	32
24	W-523	Lockwasher - 3/8.....	52	52	60	60
25	D12714	U-Bolt - 3/8.....	8	8	8	8
26	D-5277	Serrated Locknut - 1/4.....	24	20	28	28
27	W-512	Hex Nut - 1/4.....	18	15	21	21
28	D-5279	Serrated Locknut - 3/8.....	12	12	12	12
29	W-514	Hex Nut - 3/8.....	52	52	60	60
30	S44307	Support Bracket - Distribution	4	4	4	4
31	S44308	Extension Bracket - Head Support.....	0	2	0	0
32	S44467	Head Support Plate	0	0	0	0
33	N19428	Hose - 2.54 ID x 2.79 OD x 5 Lg.....	6	5	7	7
34	N32498	Pipe - 2 1/2 OD x 14 Ga.....	6	5	7	7
35	C-219	U-Bolt - 5/8 x 4 x 5 9/16	4	4	4	4
36	W-526	Lockwasher - 5/8.....	4	4	4	4
37	W-517	Hex Nut - 5/8.....	4	4	4	4
38	W-485	Hex Bolt - 1/2 x 1 1/4 Lg	4	4	4	4
39	W-525	Lockwasher - 1/2	4	4	4	4
40	W-516	Hex Nut - 1/2	4	4	4	4

Distribution - 8XL Series Air Cart Single Shoot Tow Between - 61 to 86 ft

8XL Series Air Cart Distribution

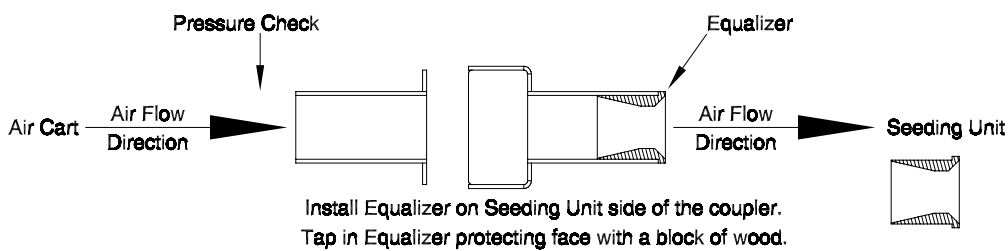
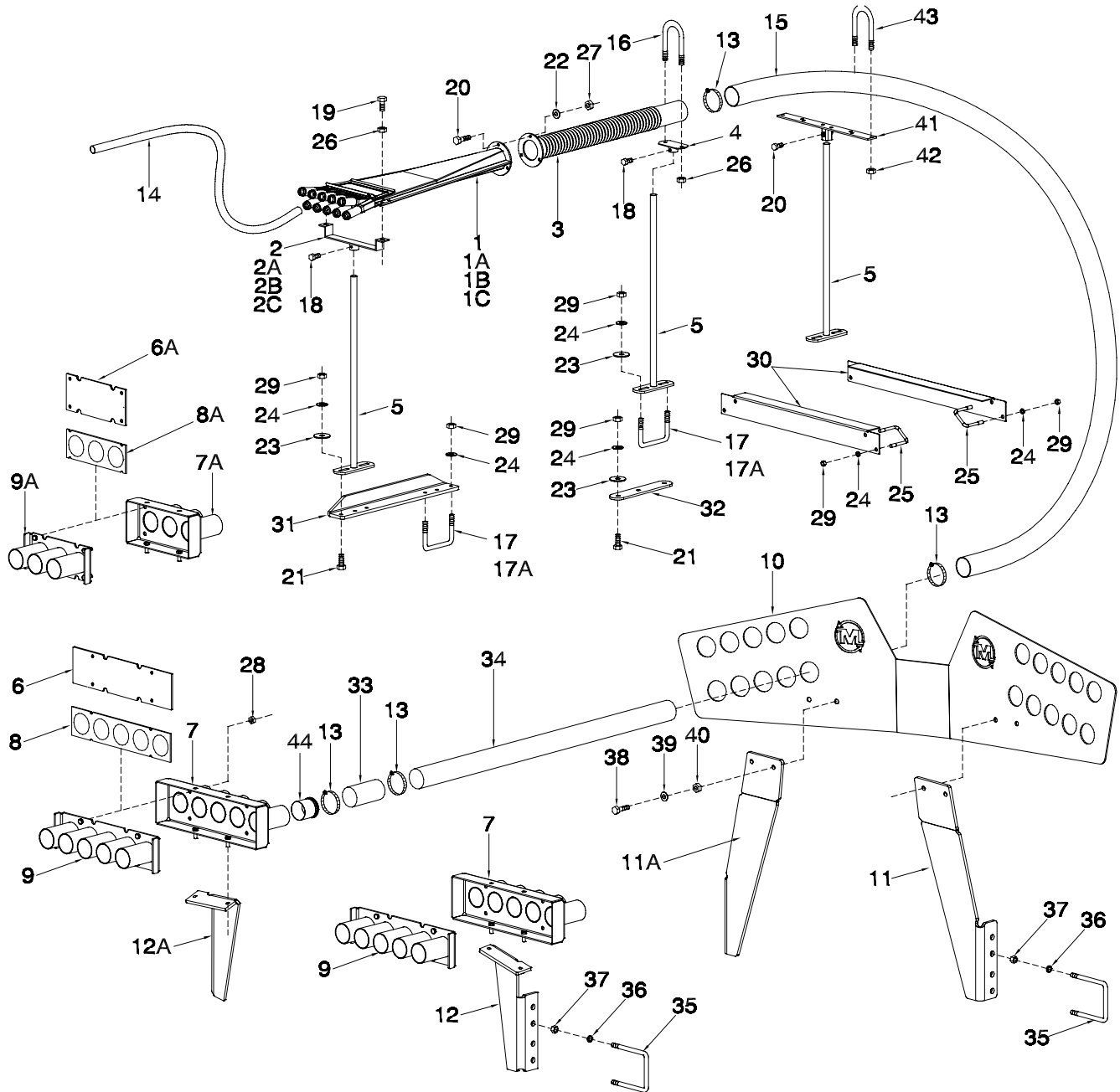

Distribtion - Single Shoot Tow Between - 61 to 86 ft

Item	Part No.	Description	No. Used								
			61 ft		71 ft		80 ft		86 ft		
			10	12	10	12	-	12	-	12	
1	N42274	Divider Assembly - 11 Outlet	-	-	-	-	-	-	-	-	-
1A	N31190	Divider Assembly - 10 Outlet	-	-	3	-	-	-	-	-	5
1B	N31189	Divider Assembly - 9 Outlet	-	-	6	-	-	8	-	-	4
1C	N31188	Divider Assembly - 8 Outlet	9	5	-	8	-	1	-	-	-
1D	N31187	Divider Assembly - 7 Outlet	-	3	-	1	-	-	-	-	-
2	N40544	Support - 11 Outlet	-	-	-	-	-	-	-	-	-
2A	N19406	Support - 10 Outlet	-	-	3	-	-	-	-	-	5
2B	N15595	Support - 9 Outlet	-	-	6	-	-	8	-	-	4
2C	N15107	Support - 8 Outlet	9	5	-	8	-	1	-	-	-
2D	N15594	Support - 7 Outlet	-	3	-	1	-	-	-	-	-
3	N15135	Pipe - Corr Diff - Divider Head.....	9	8	9	9	-	9	-	-	9
4	N15102	Support - Rear.....	9	8	9	9	-	9	-	-	9
5	N19531	Support - Bottom - Rod 24"	20	18	20	20	-	20	-	-	20
6	N39877	Cover Plate - 5 Run	4	4	4	4	-	4	-	-	4
7	S39743	Coupler - 5 Run - Tillage.....	2	2	2	2	-	2	-	-	2
8	S39752	Gasket Seal - 5 Run	2	2	2	2	-	2	-	-	2
9	S39747	Coupler - 5 Run - Cart	2	2	2	2	-	2	-	-	2
10	S39336	Carrier Plate - Distribution	1	1	1	1	-	1	-	-	1
11	S45821	Plate - Left	1	1	1	1	-	1	-	-	1
11A	S45822	Plate - Right.....	1	1	1	1	-	1	-	-	1
12	S45823	Plate - Left	1	1	1	1	-	1	-	-	1
12A	S45824	Plate - Right.....	1	1	1	1	-	1	-	-	1
13	N11905	Hose Clamp - 2 1/2	36	28	36	36	-	36	-	-	36
14	R480034	Hose - .929 ID x 1.169 OD/ft (75 ft roll)..	600	525	675	675	-	825	-	-	825
15	R480055	Hose - 2 1/2 ID/ft (100 ft rolls).....	225	200	275	275	-	275	-	-	275
16	N15096	U Bolt 1/4 x 2.5 x 3 1/4 lg	9	8	9	9	-	9	-	-	9
17	N15098	U-Bolt - 3/8 x 4 x 5.....	24	22	24	24	-	24	-	-	24
17A	N15097	U-Bolt - 3/8 x 2 x 5.....	20	18	20	20	-	20	-	-	20
18	N24396	Setscrew - 1/4 x 1/2.....	20	18	20	20	-	20	-	-	20
19	K-3830	Hex Bolt - 1/4 x 1/2 Lg.....	18	16	18	18	-	18	-	-	18
20	W-469	Hex Bolt - 1/4 x 3/4 Lg.....	27	24	27	27	-	27	-	-	27
21	W-187	Hex Bolt - 3/8 x 1 1/4 Lg.....	15	6	15	15	-	15	-	-	15
22	W-521	Lockwasher - 1/4	27	24	27	27	-	27	-	-	27
23	D-5579	Flatwasher - 3/8.....	40	36	40	40	-	40	-	-	40
24	W-523	Lockwasher - 3/8	79	66	79	79	-	79	-	-	79
25	D12714	U-Bolt - 3/8	8	8	8	8	-	8	-	-	8
26	D-5277	Serrated Locknut - 1/4	36	32	36	36	-	36	-	-	36
27	W-512	Hex Nut - 1/4	27	24	27	27	-	27	-	-	27
28	D-5279	Serrated Locknut - 3/8.....	12	12	12	12	-	12	-	-	12
29	W-514	Hex Nut - 3/8	79	66	79	79	-	79	-	-	79
30	S44307	Support Bracket - Distribution.....	4	4	4	4	-	4	-	-	4
31	S44308	Extension Bracket - Head Support	0	4	7	7	-	7	-	-	7
32	S44467	Head Support Plate	0	0	1	1	-	1	-	-	1
33	N19428	Hose - 2.54 ID x 2.79 OD x 5 Lg	9	8	9	9	-	9	-	-	9
34	N32498	Pipe - 2 1/2 OD x 14 Ga	9	8	9	9	-	9	-	-	9
35	C-219	U-Bolt - 5/8 x 4 x 5 9/16.....	4	4	4	4	-	4	-	-	4
36	W-526	Lockwasher - 5/8	4	4	4	4	-	4	-	-	4
37	W-517	Hex Nut - 5/8	4	4	4	4	-	4	-	-	4
38	W-485	Hex Bolt - 1/2 x 1 1/4 Lg	4	4	4	4	-	4	-	-	4
39	W-525	Lockwasher - 1/2	4	4	4	4	-	4	-	-	4
40	W-516	Hex Nut - 1/2	4	4	4	4	-	4	-	-	4
41	N48297	Hose Support - 80 & 86.....	0	0	0	0	-	2	-	-	2
42	N22778	Locknut - 1/4 nylon insert	0	0	0	0	-	16	-	-	16
43	N37630	U-Bolt - 1/4 x 2 3/4 x 3 3/4.....	0	0	0	0	-	8	-	-	8
44	N37920	Equalizer.....	5	5	3	3	-	5	-	-	5

Distribution - 8XL Series Air Cart
Dual Shot Tow Behind - 25 Ft and 31 Ft

8XL Series Air Cart Distribution

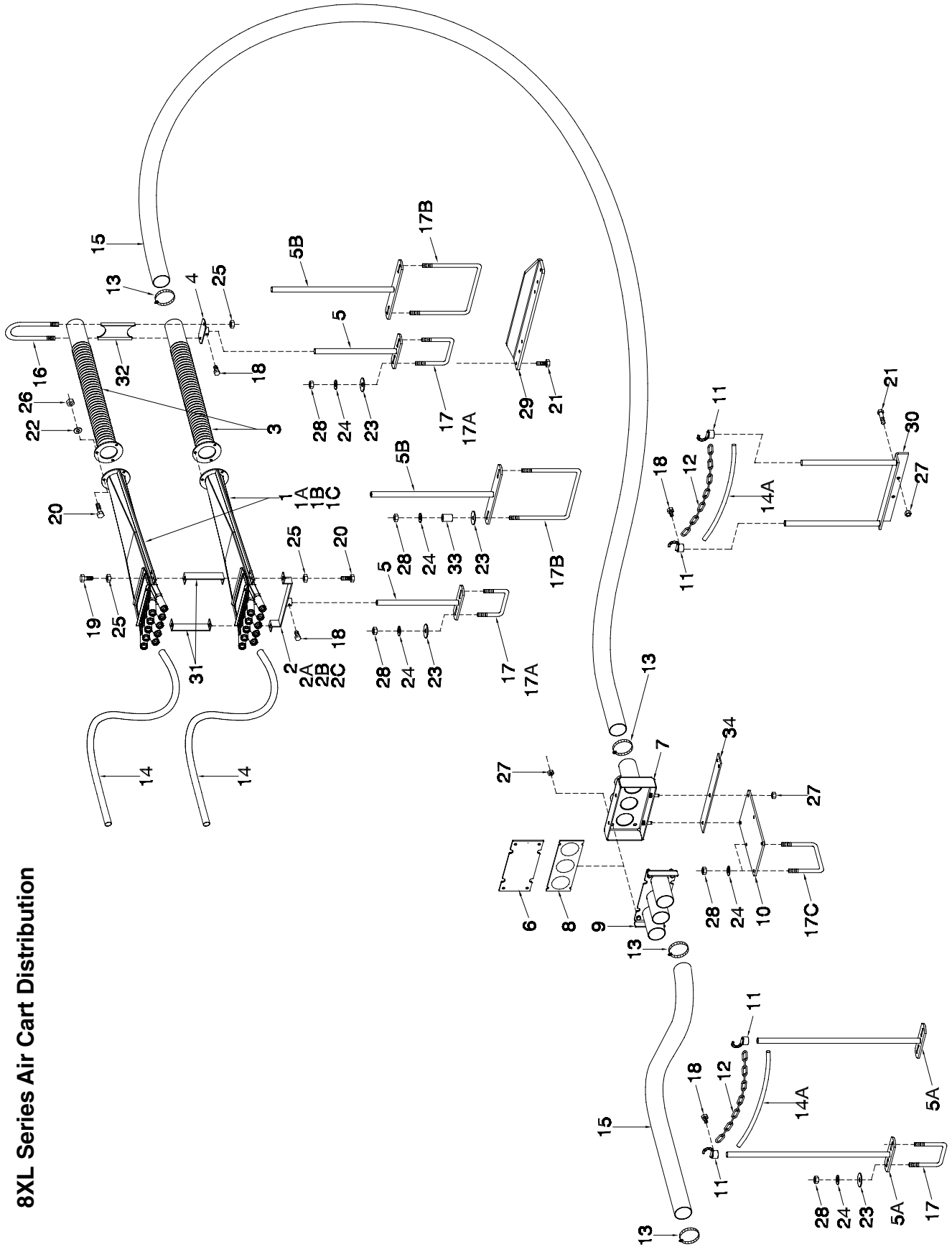

Distribution - Dual Shoot Tow Behind - 25 Ft and 31 Ft

Item	Part No.	Description	No: Used			
			25 ft		31 ft	
			10	12	10	12
1	N42274	Divider Assembly - 11 Outlet	-	-	-	-
1A	N31190	Divider Assembly - 10 Outlet.....	-	-	-	-
1B	N31189	Divider Assembly - 9 Outlet.....	-	2	-	-
1C	N31188	Divider Assembly - 8 Outlet.....	4	4	2	6
1D	N31187	Divider Assembly - 7 Outlet.....	4	-	8	2
2	N40544	Support - 11 Outlet.....	-	-	-	-
2A	N19406	Support - 10 Outlet.....	-	-	-	-
2B	N15595	Support - 9 Outlet.....	-	1	-	-
2C	N15107	Support - 8 Outlet.....	2	2	1	3
2D	N15594	Support - 7 Outlet.....	2	-	4	1
3	N15135	Pipe - Corr Diff - Divider Head	8	6	10	8
4	N15102	Support - Rear	4	3	5	4
5	N15105	Support - Bottom - Rod 12".....	8	6	8	8
5A	N19531	Support - Bottom - Rod 24".....	2	2	2	2
5B	N45694	Support - Wide - Bottom - Rod 14".....	-	2	2	-
6	N39876	Cover Plate - 3 Run.....	4	4	4	4
7	S39844	Coupler - 3 Run - Tillage	4	4	4	4
8	S39885	Gasket Seal - 3 Run.....	4	4	4	4
9	S39843	Coupler - 3 Run - Cart	4	4	4	4
10	S44463	Mount - Coupler	2	2	2	2
11	N19717	Hook - Chain	4	4	4	4
12	N19448	Chain - 80 Link.....	2	2	2	2
13	N11905	Hose Clamp - 2 1/2.....	32	24	40	32
14	R480034	Hose - .929 ID x 1.169 OD/ft (75 ft roll)	675	600	825	675
14A	R480034	Hose - .929 ID x 1.169 OD x 1.5 ft (75 ft roll)	2	2	2	2
15	R480055	Hose - 2 1/2 ID/ft (100 ft rolls)	150	100	200	150
16	N16504	U-Bolt - 1/4 x 2 9/16 x 9 1/2 Lg	4	3	5	4
17	N15098	U-Bolt - 3/8 x 4 x 5	6	4	6	6
17A	N15097	U-Bolt - 3/8 x 2 x 5	4	2	4	4
17B	N40715	U-Bolt - 3/8 x 8 x 9 3/4	-	2	2	-
17C	N34025	U-Bolt - 3/8 x 5 x 8	4	4	4	4
18	N24396	Setscrew - 1/4 x 1/2	12	10	14	12
19	K-3830	Hex Bolt - 1/4 x 1/2 Lg	8	6	10	8
20	W-469	Hex Bolt - 1/4 x 3/4 Lg	32	27	40	32
21	W-187	Hex Bolt - 3/8 x 1 1/4 Lg	10	6	6	10
22	W-521	Lockwasher - 1/4	24	18	30	24
23	D-5579	Flatwasher - 3/8	36	32	36	36
24	W-523	Lockwasher - 3/8.....	36	32	36	36
25	D-5277	Serrated Locknut - 1/4.....	24	20	30	24
26	W-512	Hex Nut - 1/4.....	24	18	30	24
27	D-5279	Serrated Locknut - 3/8.....	26	26	26	26
28	W-514	Hex Nut - 3/8.....	36	32	36	36
29	S44308	Extension Bracket - Head Support.....	4	2	2	4
30	N45696	Hose Support.....	1	1	1	1
31	N16689	Bracket Front - Dual Shoot Heads.....	8	6	10	8
32	N16507	Spacer - Rear - Dual Shoot Heads	4	3	5	4
33	N11750	Bushing - 0.385 ID x 0.625 OD x 1 1/16 Lg	-	4	4	-
34	N45684	Bracket - Air Cart Hydraulic Quick Coupler Mount	1	1	1	1

Distribution - 8XL Series Air Cart
Dual Shoot Tow Behind - 41 to 51 ft

8XL Series Air Cart Distribution

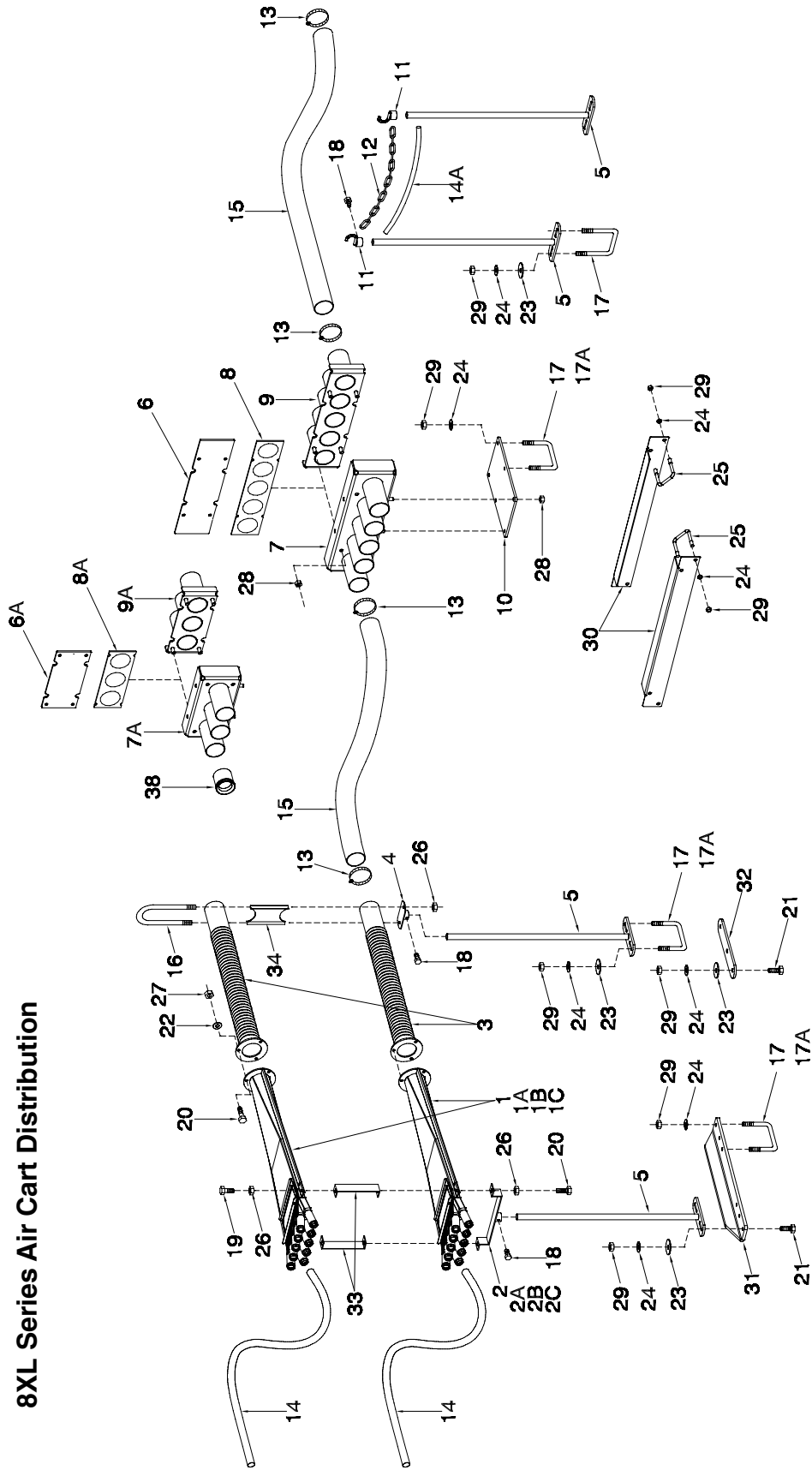

Distribution - Dual Shoot Tow Behind - 41 to 51 ft

Item	Part No.	Description	No: Used			
			41 ft		51 ft	
			10	12	10	12
1	N42274	Divider Assembly - 11 Outlet	-	-	-	-
1A	N31190	Divider Assembly - 10 Outlet.....	-	-	-	-
1B	N31189	Divider Assembly - 9 Outlet.....	4	2	8	-
1C	N31188	Divider Assembly - 8 Outlet.....	8	8	6	4
1D	N31187	Divider Assembly - 7 Outlet.....	-	-	-	10
2	N40544	Support - 11 Outlet.....	-	-	-	-
2A	N19406	Support - 10 Outlet.....	4	-	-	-
2B	N15595	Support - 9 Outlet.....	8	2	8	-
2C	N15107	Support - 8 Outlet.....	-	8	6	4
2D	N15594	Support - 7 Outlet.....	-	-	-	10
3	N15135	Pipe - Corr Diff - Divider Head	12	10	14	14
4	N15102	Support - Rear	6	5	7	7
5	N19531	Support - Bottom - Rod 24"	14	12	16	16
6	N39877	Cover Plate - 5 Run.....	0	0	8	8
6A	N39876	Cover Plate - 3 Run.....	8	8	0	0
7	S39743	Coupler - 5 Run - Tillage	0	0	4	4
7A	S39844	Coupler - 3 Run - Tillage	4	4	0	0
8	S39752	Gasket Seal - 5 Run.....	0	0	4	4
8A	S39885	Gasket Seal - 3 Run.....	4	4	0	0
9	S39747	Coupler - 5 Run - Cart.....	0	0	4	4
9A	S39843	Coupler - 3 Run - Cart	4	4	0	0
10	S44463	Mount - Coupler	2	2	2	2
11	N19717	Hook - Chain.....	2	2	2	2
12	N19448	Chain - 80 Link.....	1	1	1	1
13	N11905	Hose Clamp - 2 1/2.....	48	40	64	56
14	R480034	Hose - .929 ID x 1.169 OD/ft (75 ft roll)	900	750	1200	1200
14A	R480034	Hose - .929 ID x 1.169 OD/ft (75 ft roll)	1.5 ft	1.5 ft	1.5 ft	1.5 ft
15	R480055	Hose - 2 1/2 ID/ft (100 ft rolls)	250	200	150	150
16	N15096	U-Bolt 1/4 x 2.5 x 3 1/4 lg.....	6	5	7	7
17	N15098	U-Bolt - 3/8 x 4 x 5	18	16	20	20
17A	N15097	U-Bolt - 3/8 x 2 x 5	14	12	16	16
18	N24396	Setscrew - 1/4 x 1/2	14	12	16	16
19	K-3830	Hex Bolt - 1/4 x 1/2 Lg.....	12	10	14	14
20	W-469	Hex Bolt - 1/4 x 3/4 Lg.....	38	32	44	44
21	W-187	Hex Bolt - 3/8 x 1 1/4 Lg.....	0	4	4	4
22	W-521	Lockwasher - 1/4.....	36	30	42	42
23	D-5579	Flatwasher - 3/8	28	24	32	32
24	W-523	Lockwasher - 3/8.....	52	52	60	60
25	D12714	U-Bolt - 3/8.....	8	8	8	8
26	D-5277	Serrated Locknut - 1/4.....	24	20	28	28
27	W-512	Hex Nut - 1/4	36	30	42	42
28	D-5279	Serrated Locknut - 3/8.....	12	12	12	12
29	W-514	Hex Nut - 3/8.....	52	52	60	60
30	S44307	Support Bracket - Distribution	4	4	4	4
31	S44308	Extension Bracket - Head Support.....	0	2	4	4
32	S44467	Head Support Plate	0	0	4	2
33	N16689	Bracket Front - Dual Shoot Heads.....	12	10	16	14
34	N16507	Spacer - Rear - Dual Shoot Heads	6	5	8	7

**Distribution - 8XL Series Air Cart
Dual Shoot Tow Behind - 61 to 86 ft**

8XL Series Air Cart Distribution

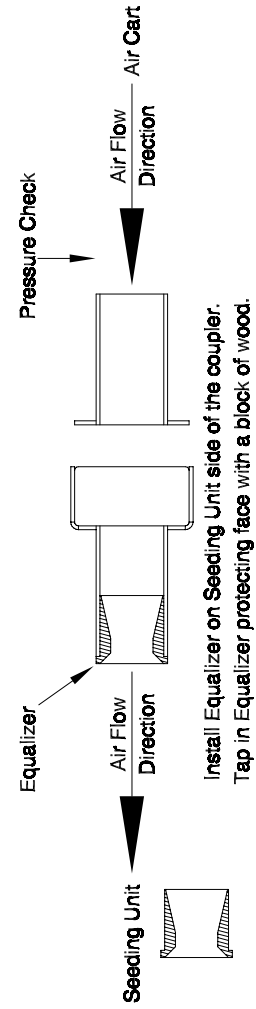
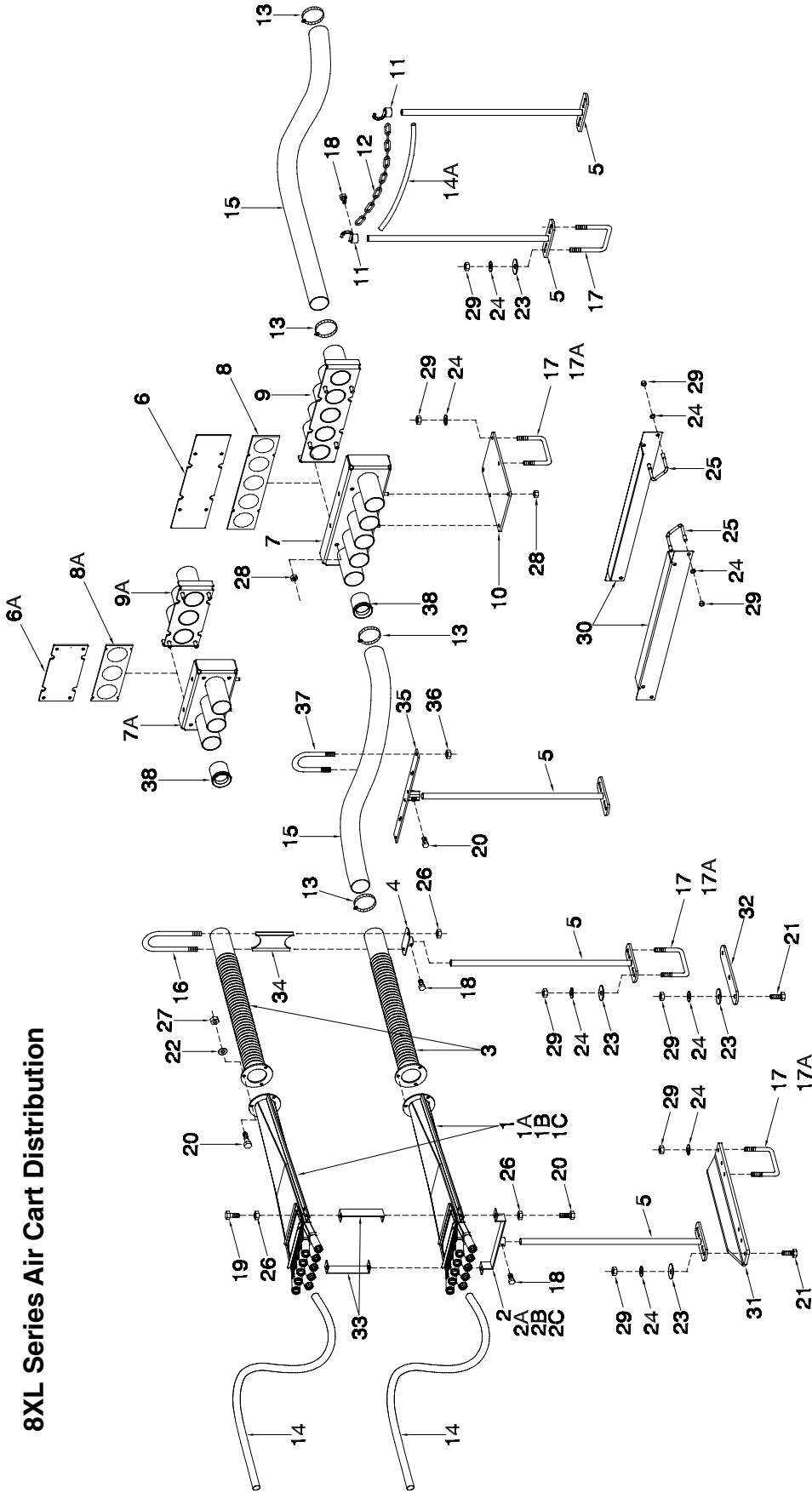

Distribution - Dual Shoot Tow Behind - 61 to 86 ft

Item	Part No.	Description	No. Used							
			61 ft		71 ft		80 ft		86 ft	
			10	12	10	12	-	12	-	12
1	N42274	Divider Assembly - 11 Outlet	-	-	-	-	-	-	-	-
1A	N31190	Divider Assembly - 10 Outlet	-	-	6	-	-	-	-	10
1B	N31189	Divider Assembly - 9 Outlet	-	-	12	-	-	16	-	8
1C	N31188	Divider Assembly - 8 Outlet	18	10	-	-	-	2	-	-
1D	N31187	Divider Assembly - 7 Outlet	-	6	-	-	-	-	-	-
2	N40544	Support - 11 Outlet	-	-	-	-	-	-	-	-
2A	N19406	Support - 10 Outlet	-	-	6	-	-	-	-	10
2B	N15595	Support - 9 Outlet	-	-	12	-	-	16	-	8
2C	N15107	Support - 8 Outlet	18	10	-	-	-	2	-	-
2D	N15594	Support - 7 Outlet	-	6	-	-	-	-	-	-
3	N15135	Pipe - Corr Diff - Divider Head	16	14	18	18	-	18	-	18
4	N15102	Support - Rear	8	7	9	9	-	9	-	9
5	N19531	Support - Bottom - Rod 24"	18	16	20	20	-	20	-	20
6	N39877	Cover Plate - 5 Run	4	4	4	4	-	4	-	4
7	S39743	Coupler - 5 Run - Tillage	4	4	4	4	-	4	-	4
8	S39752	Gasket Seal - 5 Run	4	4	4	4	-	4	-	4
9	S39747	Coupler - 5 Run - Cart	4	4	4	4	-	4	-	4
10	S44463	Mount - Coupler	2	2	2	2	-	2	-	2
11	N19717	Hook - Chain	2	2	2	2	-	2	-	2
12	N19448	Chain - 80 Link	1	1	1	1	-	1	-	1
13	N11905	Hose Clamp - 2 1/2	64	56	72	72	-	72	-	72
14	R480034	Hose - .929 ID x 1.169 OD/ft (75 ft roll) ..	1200	1050	1350	1350	-	1650	-	1650
14A	R480034	Hose - .929 ID x 1.169 OD/ft (75 ft roll) ..	1.5 ft	1.5 ft	1.5 ft	1.5 ft	1.5 ft	1.5 ft	1.5 ft	1.5 ft
15	R480055	Hose - 2 1/2 ID/ft (100 ft rolls)	450	400	550	550	-	550	-	550
16	N16504	U-Bolt - 1/4 x 2 9/16 x 9 1/2 Lg	8	7	9	9	-	9	-	9
17	N15098	U-Bolt - 3/8 x 4 x 5	22	20	24	24	-	24	-	24
17A	N15097	U-Bolt - 3/8 x 2 x 5	18	16	20	20	-	20	-	20
18	N24396	Setscrew - 1/4 x 1/2	18	16	20	20	-	20	-	20
19	K-3830	Hex Bolt - 1/4 x 1/2 Lg	16	14	18	18	-	18	-	18
20	W-469	Hex Bolt - 1/4 x 3/4 Lg	50	44	56	56	-	56	-	56
21	W-187	Hex Bolt - 3/8 x 1 1/4 Lg	6	4	15	15	-	15	-	15
22	W-521	Lockwasher - 1/4	48	42	54	54	-	54	-	54
23	D-5579	Flatwasher - 3/8	36	32	40	40	-	40	-	40
24	W-523	Lockwasher - 3/8	66	60	79	79	-	79	-	79
25	D12714	U-Bolt - 3/8	8	8	8	8	-	8	-	8
26	D-5277	Serrated Locknut - 1/4	34	30	38	38	-	38	-	38
27	W-512	Hex Nut - 1/4	48	42	54	54	-	54	-	54
28	D-5279	Serrated Locknut - 3/8	12	12	12	12	-	12	-	12
29	W-514	Hex Nut - 3/8	66	60	79	79	-	79	-	79
30	S44307	Support Bracket - Distribution	4	4	4	4	-	4	-	4
31	S44308	Extension Bracket - Head Support	2	4	7	7	-	7	-	7
32	S44467	Head Support Plate	0	0	1	1	-	1	-	1
33	N16689	Bracket Front - Dual Shoot Heads	16	14	18	18	-	18	-	18
34	N16507	Spacer - Rear - Dual Shoot Heads	8	7	9	9	-	9	-	9
35	N48297	Hose Support - 80 & 86	0	0	0	0	-	2	-	2
36	N22778	Locknut - 1/4 nylon insert	0	0	0	0	-	16	-	16
37	N37630	U-Bolt - 1/4 x 2 3/4 x 3 3/4	0	0	0	0	-	8	-	8
38	N37920	Equalizer	10	10	6	6	-	10	-	10

Distribution - 8XL Series Air Cart
Dual Shoot Tow Between - 25 Ft and 31 Ft

8XL Series Air Cart Distribution

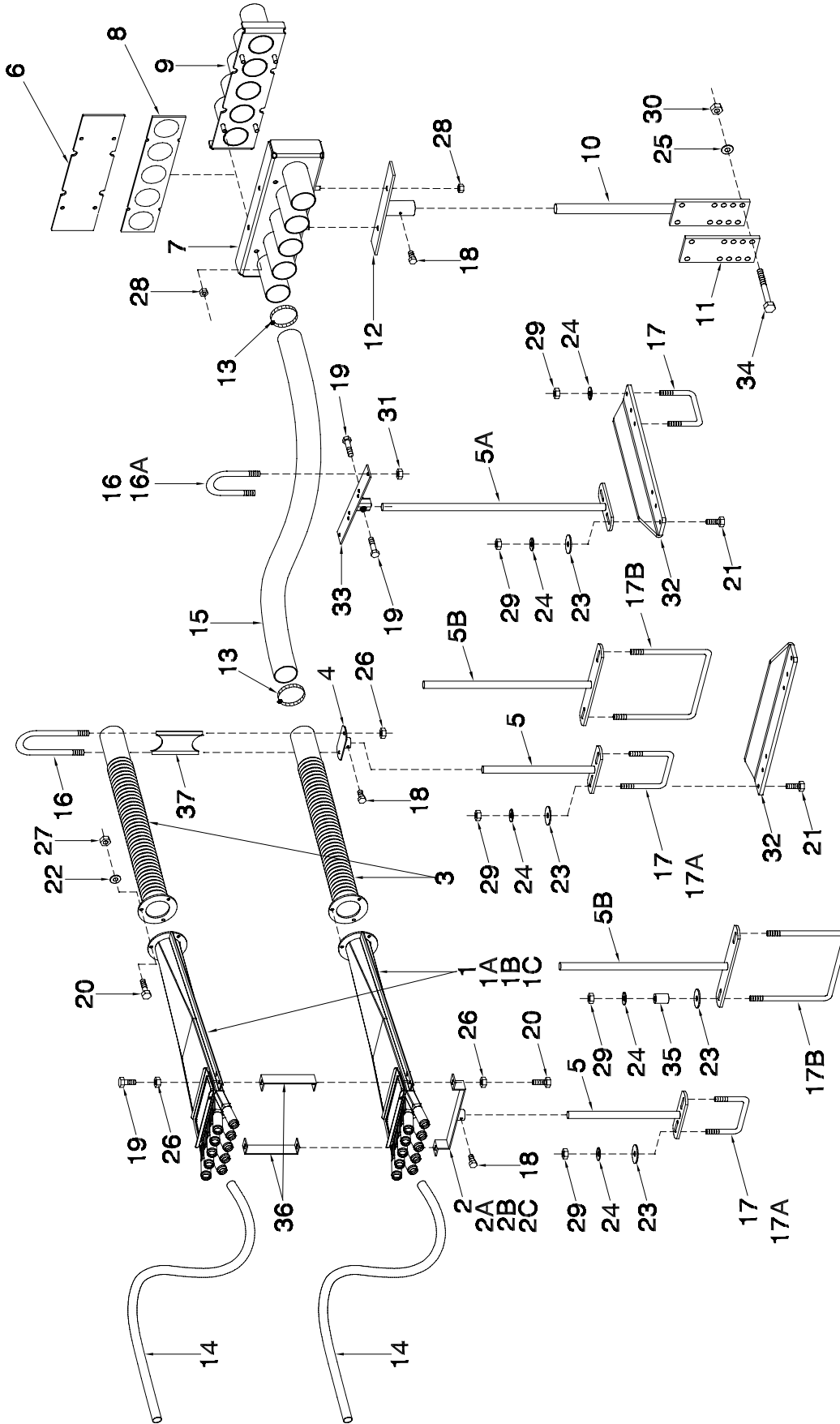

Distribution - Dual Shoot Tow Between - 25 Ft and 31 Ft

Item	Part No.	Description	No: Used			
			25 ft		31 ft	
			10	12	10	12
1	N42274	Divider Assembly - 11 Outlet	-	-	-	-
1A	N31190	Divider Assembly - 10 Outlet.....	-	-	-	-
1B	N31189	Divider Assembly - 9 Outlet.....	-	2	-	-
1C	N31188	Divider Assembly - 8 Outlet.....	4	4	2	6
1D	N31187	Divider Assembly - 7 Outlet.....	4	-	8	2
2	N40544	Support - 11 Outlet.....	-	-	-	-
2A	N19406	Support - 10 Outlet.....	-	-	-	-
2B	N15595	Support - 9 Outlet.....	-	1	-	-
2C	N15107	Support - 8 Outlet.....	3	2	1	3
2D	N15594	Support - 7 Outlet.....	1	-	4	1
3	N15135	Pipe - Corr Diff - Divider Head	8	6	10	8
4	N15102	Support - Rear	4	3	5	4
5	N15105	Support - Bottom - Rod 12"	8	6	8	8
5A	N19531	Support - Bottom - Rod 24"	2	2	2	2
5B	N45694	Support - Wide - Bottom - Rod 14"	-	2	2	-
6	N39877	Cover Plate - 5 Run.....	2	2	2	2
7	S39743	Coupler - 5 Run - Tillage	2	2	2	2
8	S39752	Gasket Seal - 5 Run	2	2	2	2
9	S39747	Coupler - 5 Run - Cart	2	2	2	2
10	N19575	Base - Hose Coupler.....	1	1	1	1
11	N19409	Plate - Mount.....	1	1	1	1
12	N39840	Mount - Coupler	1	1	1	1
13	N11905	Hose Clamp - 2 1/2	32	24	40	32
14	R480034	Hose - .929 ID x 1.169 OD/ft (75 ft roll)	675	600	825	675
15	R480055	Hose - 2 1/2 ID/ft (100 ft rolls)	150	100	200	150
16	N16504	U-Bolt - 1/4 x 2 9/16 x 9 1/2 Lg	8	3	9	8
16A	N37630	U-Bolt - 1/4 x 2 3/4 x 3 3/4 Lg	2	2	2	2
17	N15098	U-Bolt - 3/8 x 4 x 5	6	4	6	6
17A	N15097	U-Bolt - 3/8 x 2 x 5	4	2	4	4
17B	N40715	U-Bolt - 3/8 x 8 x 9 3/4	-	2	2	-
18	N24396	Setscrew - 1/4 x 1/2	8	6	12	8
19	K-3830	Hex Bolt - 1/4 x 1/2 Lg	12	10	14	12
20	W-469	Hex Bolt - 1/4 x 3/4 Lg	32	24	40	32
21	W-187	Hex Bolt - 3/8 x 1 1/4 Lg	8	4	4	8
22	W-521	Lockwasher - 1/4	24	18	30	24
23	D-5579	Flatwasher - 3/8	20	16	24	20
24	W-523	Lockwasher - 3/8.....	28	16	28	28
25	W-525	Lockwasher - 1/2.....	4	4	4	4
26	D-5277	Serrated Locknut - 1/4.....	24	18	30	24
27	W-512	Hex Nut - 1/4.....	24	18	30	24
28	D-5279	Serrated Locknut - 3/8.....	12	12	12	12
29	W-514	Hex Nut - 3/8.....	28	20	28	28
30	W-516	Hex Nut - 1/2.....	4	4	4	4
31	N22778	Locknut Nylon Insert - 1/4	8	4	8	8
32	S44308	Extension Bracket - Head Support.....	4	2	2	4
33	N40704	Support - Hose.....	2	2	2	2
34	S-951	Hex Bolt - 1/2 x 4 1/2 Lg.....	4	4	4	4
35	N11750	Bushing - 0.385 ID x 0.625 OD x 1 1/16 Lg	-	4	4	-
36	N16689	Bracket Front - Dual Shoot Heads.....	8	6	10	8
37	N16507	Spacer - Rear - Dual Shoot Heads	4	3	5	4

Distribution - 8XL Series Air Cart Dual Shoot Tow Between - 41 to 51 ft

8XL Series Air Cart Distribution

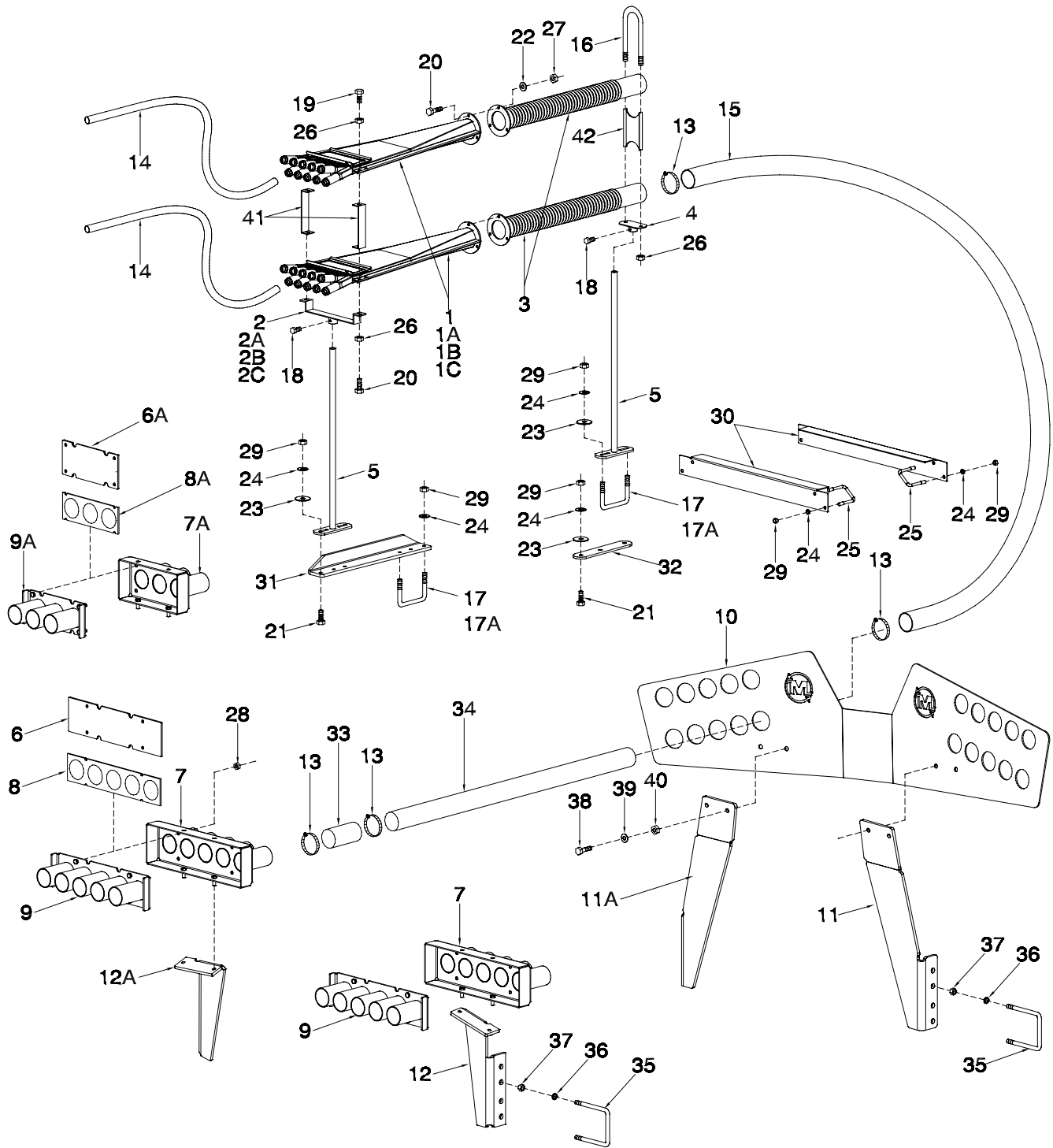

Distribution - Dual Shoot Tow Between - 41 to 51 ft

Item	Part No.	Description	No: Used			
			41 ft		51 ft	
			10	12	10	12
1	N42274	Divider Assembly - 11 Outlet	-	-	-	-
1A	N31190	Divider Assembly - 10 Outlet.....	-	-	-	-
1B	N31189	Divider Assembly - 9 Outlet.....	4	2	8	-
1C	N31188	Divider Assembly - 8 Outlet.....	8	8	6	4
1D	N31187	Divider Assembly - 7 Outlet.....	-	-	-	10
2	N40544	Support - 11 Outlet.....	-	-	-	-
2A	N19406	Support - 10 Outlet.....	4	-	-	-
2B	N15595	Support - 9 Outlet.....	8	2	8	-
2C	N15107	Support - 8 Outlet.....	-	8	6	4
2D	N15594	Support - 7 Outlet.....	-	-	-	10
3	N15135	Pipe - Corr Diff - Divider Head	12	10	16	14
4	N15102	Support - Rear	6	5	8	7
5	N19531	Support - Bottom - Rod 24".....	14	12	18	16
6	N39877	Cover Plate - 5 Run.....	0	0	4	4
6A	N39876	Cover Plate - 3 Run.....	4	4	0	0
7	S39743	Coupler - 5 Run - Tillage	0	0	4	4
7A	S39844	Coupler - 3 Run - Tillage	4	4	0	0
8	S39752	Gasket Seal - 5 Run	0	0	4	4
8A	S39885	Gasket Seal - 3 Run.....	4	4	0	0
9	S39747	Coupler - 5 Run - Cart	0	0	4	4
9A	S39843	Coupler - 3 Run - Cart	4	4	0	0
10	S39336	Carrier Plate - Distribution.....	1	1	1	1
11	S45821	Plate - Left.....	1	1	1	1
11A	S45822	Plate - Right	1	1	1	1
12	S45823	Plate - Left.....	1	1	1	1
12A	S45824	Plate - Right	1	1	1	1
13	N11905	Hose Clamp - 2 1/2	24	20	32	28
14	R480034	Hose - .929 ID x 1.169 OD/ft (75 ft roll)	900	750	1200	1050
15	R480055	Hose - 2 1/2 ID/ft (100 ft rolls)	250	200	200	200
16	N16504	U-Bolt - 1/4 x 2 9/16 x 9 1/2 Lg	6	5	8	7
17	N15098	U-Bolt - 3/8 x 4 x 5	18	16	22	20
17A	N15097	U-Bolt - 3/8 x 2 x 5	14	12	18	16
18	N24396	Setscrew - 1/4 x 1/2	14	12	18	16
19	K-3830	Hex Bolt - 1/4 x 1/2 Lg	12	10	16	14
20	W-469	Hex Bolt - 1/4 x 3/4 Lg	38	32	50	44
21	W-187	Hex Bolt - 3/8 x 1 1/4 Lg	0	4	6	4
22	W-521	Lockwasher - 1/4	36	30	48	42
23	D-5579	Flatwasher - 3/8	28	24	36	32
24	W-523	Lockwasher - 3/8.....	52	52	66	60
25	D12714	U-Bolt - 3/8.....	8	8	8	8
26	D-5277	Serrated Locknut - 1/4.....	26	22	34	30
27	W-512	Hex Nut - 1/4.....	36	30	48	42
28	D-5279	Serrated Locknut - 3/8.....	12	12	12	12
29	W-514	Hex Nut - 3/8.....	52	52	66	60
30	S44307	Support Bracket - Distribution	4	4	4	4
31	S44308	Extension Bracket - Head Support.....	0	2	2	4
32	S44467	Head Support Plate	0	0	0	0
33	N19428	Hose - 2.54 ID x 2.79 OD x 5 Lg.....	12	10	16	14
34	N32498	Pipe - 2 1/2 OD x 14 Ga.....	12	10	16	14
35	C-219	U-Bolt - 5/8 x 4 x 5 9/16	4	4	4	4
36	W-526	Lockwasher - 5/8.....	4	4	4	4
37	W-517	Hex Nut - 5/8.....	4	4	4	4
38	W-485	Hex Bolt - 1/2 x 1 1/4 Lg	4	4	4	4
39	W-525	Lockwasher - 1/2	4	4	4	4
40	W-516	Hex Nut - 1/2	4	4	4	4
41	N16689	Bracket Front - Dual Shoot Heads.....	12	10	16	14
42	N16507	Spacer - Rear - Dual Shoot Heads	6	5	8	7

Distribution - 8XL Series Air Cart Dual Shoot Tow Between - 61 to 86 ft

8XL Series Air Cart Distribution

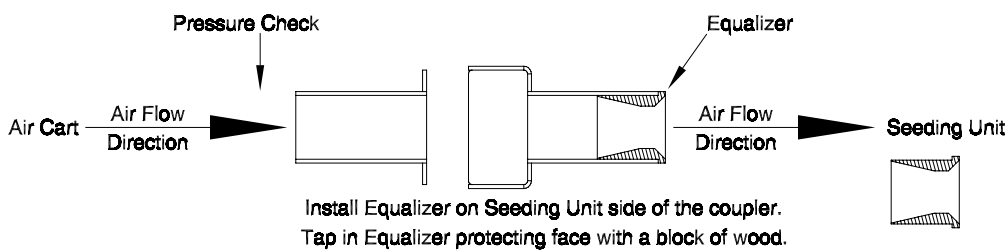
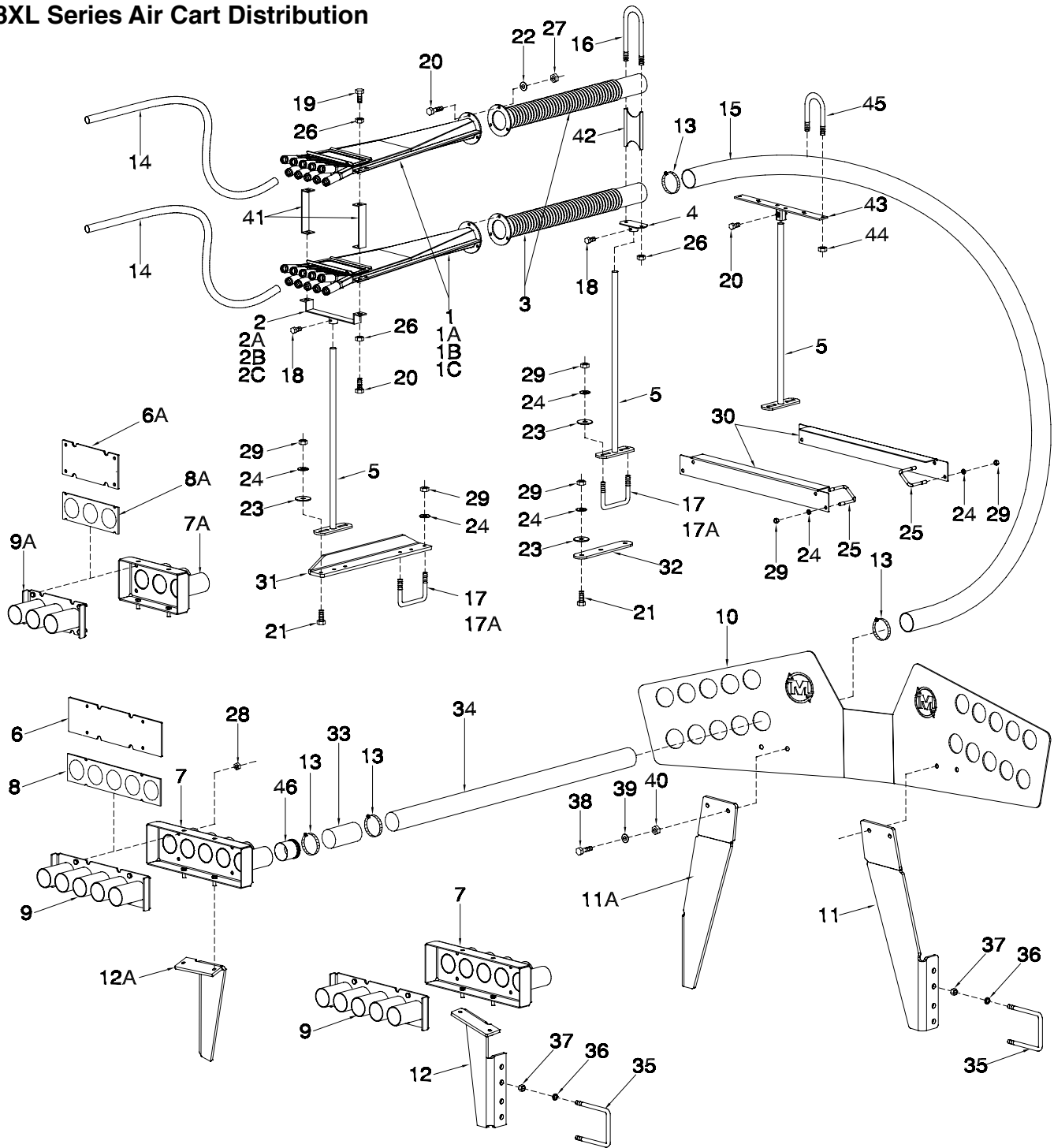

Distribution - Dual Shoot Tow Between - 61 to 86 ft

Item	Part No.	Description	No. Used							
			61 ft		71 ft		80ft		86ft	
			10	12	10	12	-	12	-	12
1	N42274	Divider Assembly - 11 Outlet	-	-	-	-	-	-	-	-
1A	N31190	Divider Assembly - 10 Outlet	-	-	6	-	-	-	-	10
1B	N31189	Divider Assembly - 9 Outlet	-	-	12	-	-	16	-	8
1C	N31188	Divider Assembly - 8 Outlet	18	10	-	-	-	2	-	-
1D	N31187	Divider Assembly - 7 Outlet	-	6	-	-	-	-	-	-
2	N40544	Support - 11 Outlet	-	-	-	-	-	-	-	-
2A	N19406	Support - 10 Outlet	-	-	6	-	-	-	-	10
2B	N15595	Support - 9 Outlet	-	-	12	-	-	16	-	8
2C	N15107	Support - 8 Outlet	18	10	-	-	-	2	-	-
2D	N15594	Support - 7 Outlet	-	6	-	-	-	-	-	-
3	N15135	Pipe - Corr Diff - Divider Head	16	14	18	18	-	18	-	18
4	N15102	Support - Rear	8	7	9	9	-	9	-	9
5	N19531	Support - Bottom - Rod 24"	18	16	20	20	-	20	-	20
6	N39877	Cover Plate - 5 Run	4	4	4	4	-	4	-	4
7	S39743	Coupler - 5 Run - Tillage	4	4	4	4	-	4	-	4
8	S39752	Gasket Seal - 5 Run	4	4	4	4	-	4	-	4
9	S39747	Coupler - 5 Run - Cart	4	4	4	4	-	4	-	4
10	S39336	Carrier Plate - Distribution	1	1	1	1	-	1	-	1
11	S45821	Plate - Left	1	1	1	1	-	1	-	1
11A	S45822	Plate - Right	1	1	1	1	-	1	-	1
12	S45823	Plate - Left	1	1	1	1	-	1	-	1
12A	S45824	Plate - Right	1	1	1	1	-	1	-	1
13	N11905	Hose Clamp - 2 1/2	32	28	36	36	-	36	-	36
14	R480034	Hose - .929 ID x 1.169 OD/ft (75 ft roll) ..	1200	1050	1350	1350	-	1650	-	1650
15	R480055	Hose - 2 1/2 ID/ft (100 ft rolls)	450	400	550	550	-	550	-	550
16	N16504	U-Bolt - 1/4 x 2 9/16 x 9 1/2 Lg	8	7	9	9	-	9	-	9
17	N15098	U-Bolt - 3/8 x 4 x 5	22	20	24	24	-	24	-	24
17A	N15097	U-Bolt - 3/8 x 2 x 5	18	16	20	20	-	20	-	20
18	N24396	Setscrew - 1/4 x 1/2	18	16	20	20	-	20	-	20
19	K-3830	Hex Bolt - 1/4 x 1/2 Lg	16	14	18	18	-	18	-	18
20	W-469	Hex Bolt - 1/4 x 3/4 Lg	50	44	56	56	-	56	-	56
21	W-187	Hex Bolt - 3/8 x 1 1/4 Lg	6	4	15	15	-	15	-	15
22	W-521	Lockwasher - 1/4	48	42	54	54	-	54	-	54
23	D-5579	Flatwasher - 3/8	36	32	40	40	-	40	-	40
24	W-523	Lockwasher - 3/8	66	60	79	79	-	79	-	79
25	D12714	U-Bolt - 3/8	8	8	8	8	-	8	-	8
26	D-5277	Serrated Locknut - 1/4	34	30	38	38	-	38	-	38
27	W-512	Hex Nut - 1/4	48	42	54	54	-	54	-	54
28	D-5279	Serrated Locknut - 3/8	12	12	12	12	-	12	-	12
29	W-514	Hex Nut - 3/8	66	60	79	79	-	79	-	79
30	S44307	Support Bracket - Distribution	4	4	4	4	-	4	-	4
31	S44308	Extension Bracket - Head Support	2	4	7	7	-	7	-	7
32	S44467	Head Support Plate	0	0	1	1	-	1	-	1
33	N19428	Hose - 2.54 ID x 2.79 OD x 5 Lg	16	14	18	18	-	18	-	18
34	N32498	Pipe - 2 1/2 OD x 14 Ga	16	14	18	18	-	18	-	18
35	C-219	U-Bolt - 5/8 x 4 x 5 9/16	4	4	4	4	-	4	-	4
36	W-526	Lockwasher - 5/8	4	4	4	4	-	4	-	4
37	W-517	Hex Nut - 5/8	4	4	4	4	-	4	-	4
38	W-485	Hex Bolt - 1/2 x 1 1/4 Lg	4	4	4	4	-	4	-	4
39	W-525	Lockwasher - 1/2	4	4	4	4	-	4	-	4
40	W-516	Hex Nut - 1/2	4	4	4	4	-	4	-	4
41	N16689	Bracket Front - Dual Shoot Heads	16	14	18	18	-	18	-	18
42	N16507	Spacer - Rear - Dual Shoot Heads	8	7	9	9	-	9	-	9
43	N48297	Hose Support - 80 & 86	0	0	0	0	-	2	-	2
44	N22778	Locknut - 1/4 nylon insert	0	0	0	0	-	16	-	16
45	N37630	U-Bolt - 1/4 x 2 3/4 x 3 3/4	0	0	0	0	-	8	-	8
46	N37920	Equalizer	10	10	6	6	-	10	-	10

Notes

Section 7: Distribution - 9 Series Carts

Section Contents

Quick Coupler	7-2
3 Outlet	7-2
5 Outlet	7-3
Single Shoot Tow Behind - 25 Ft and 31 Ft	7-4
Single Shoot Tow Behind - 41 to 51 ft.....	7-6
Single Shoot Tow Behind - 61 to 90 ft.....	7-8
Single Shoot Tow Between - 25 Ft and 31 Ft	7-10
Single Shoot Tow Between - 41 to 51 ft.....	7-12
Single Shoot Tow Between - 61 to 90 ft.....	7-14
Dual Shoot Tow Behind - 25 Ft and 31 Ft.....	7-16
Dual Shoot Tow Behind - 41 to 51 ft	7-18
Dual Shoot Tow Behind - 61 to 90 ft	7-20
Dual Shoot Tow Behind - 80 ft - 2021	7-22
Dual Shoot Tow Behind - 90 ft - 2018.....	7-24
Dual Shoot Tow Between - 25 Ft and 31 Ft.....	7-28
Dual Shoot Tow Between - 41 to 51 ft.....	7-30
Dual Shoot Tow Between - 61 to 90 ft.....	7-32
Broadcast - Mounting Brackets	7-34
Stainless Head Conversion Kits	7-36
Chart	7-36
Divider Head Mounting Stands	7-37
Divider Head Assembly.....	7-39

Quick Coupler 3 Outlet

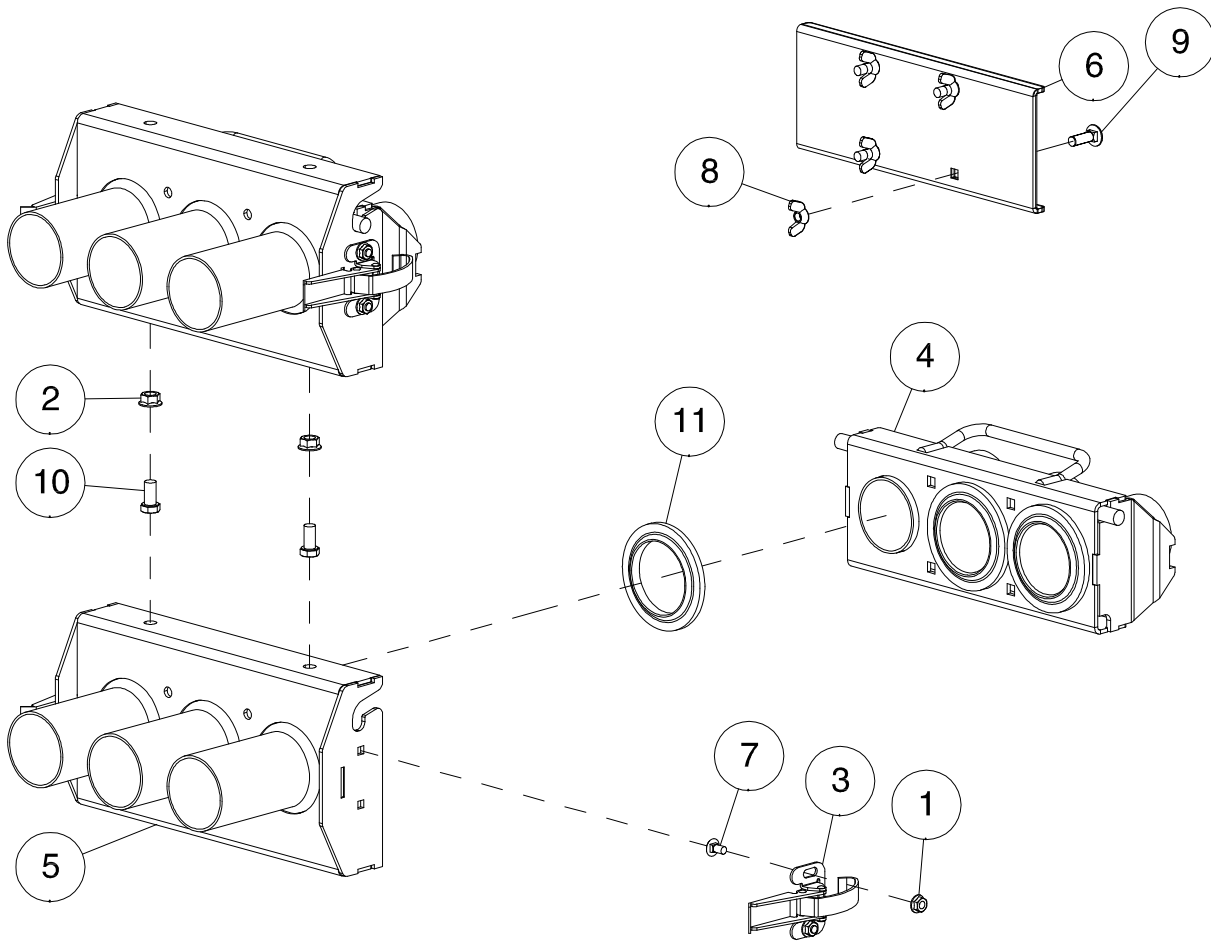

Item	Part No.	Description	Qty
1	D-5277	Flange Lock Nut - 1/4 Unc Serrated.....	8
2	D-5279	Flange Lock Nut - 3/8 Unc Serrated.....	2
3	N42213	Latch	4
4	N51983	Quick Coupler - 3 Run - Cart - Contains Item 11	2
5	N53200	Quick Coupler - 3 Run - Drill	2
6	N53207	Cover Plate - 3 Run.....	2
7	N53215	Carriage Bolt - 1/4 x 1/2 Lg	8
8	S-747	Wing Nut - 5/16	8
9	S33420	Carriage Bolt - 5/16 x 1 Lg	8
10	W-867	Hex Bolt - 3/8 x 3/4 Lg.....	2
11	N40735	Washer Seal.....	6
	N16170	Clear Silicon 305ml - used to assemble 11 to 4	AsReq

Quick Coupler 5 Outlet

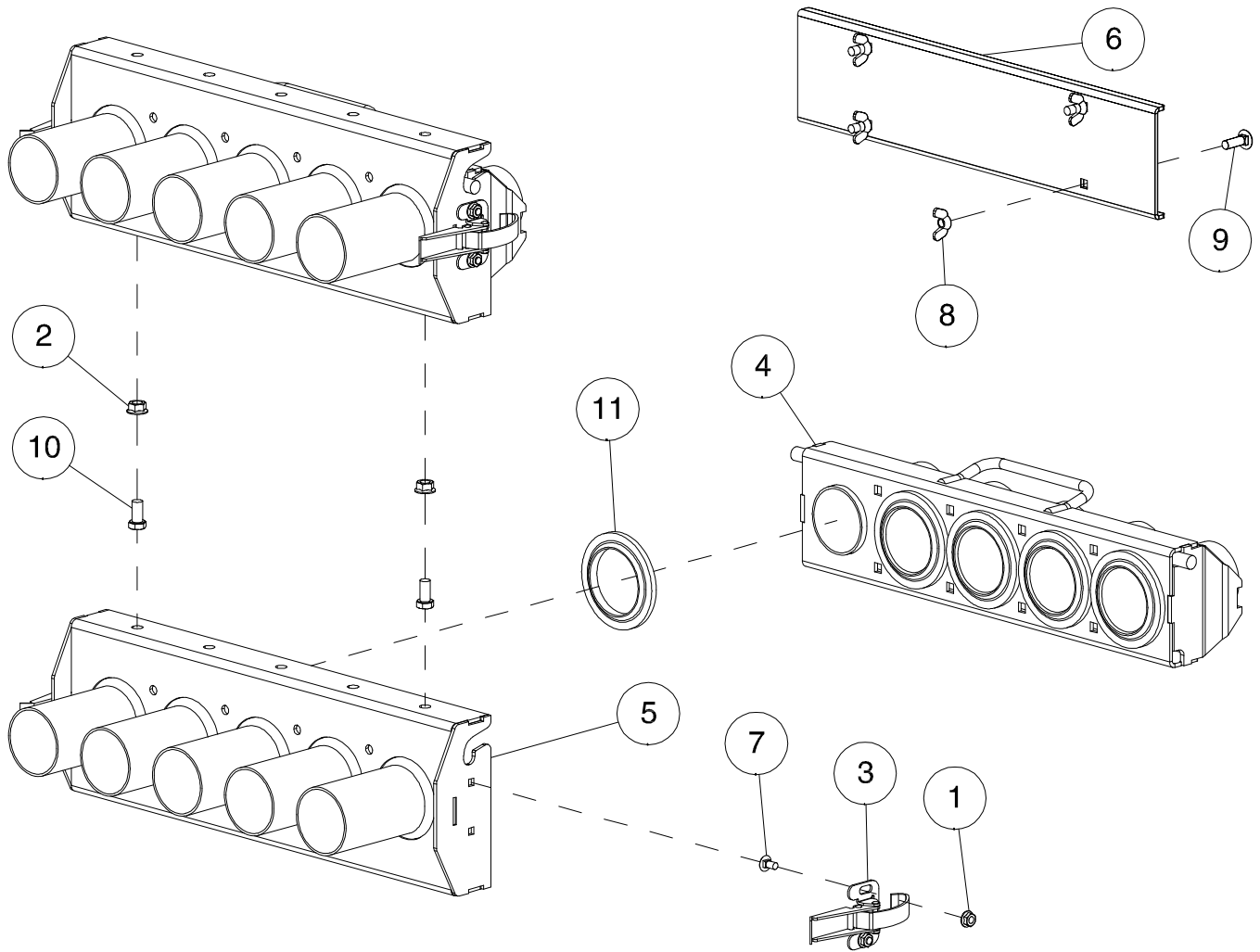

Item	Part No.	Description	Qty
1	D-5277	Flange Lock Nut - 1/4 Unc Serrated.....	8
2	D-5279	Flange Lock Nut - 3/8 Unc Serrated.....	2
3	N42213	Latch	4
4	N51955	Quick Coupler - 5 Run - Cart - Contains Item 11	2
5	N51960	Quick Coupler - 5 Run - Drill	2
6	N53209	Cover Plate - 5 Run.....	2
7	N53215	Carriage Bolt - 1/4 x 1/2 Lg	8
8	S-747	Wing Nut - 5/16	8
9	S33420	Carriage Bolt - 5/16 x 1 Lg	8
10	W-867	Hex Bolt - 3/8 x 3/4 Lg.....	2
11	N40735	Washer Seal.....	6
	N16170	Clear Silicon 305ml - used to assemble 11 to 4	AsReq

Distribution - 9 Series Air Cart Single Shoot Tow Behind - 25 Ft and 31 Ft

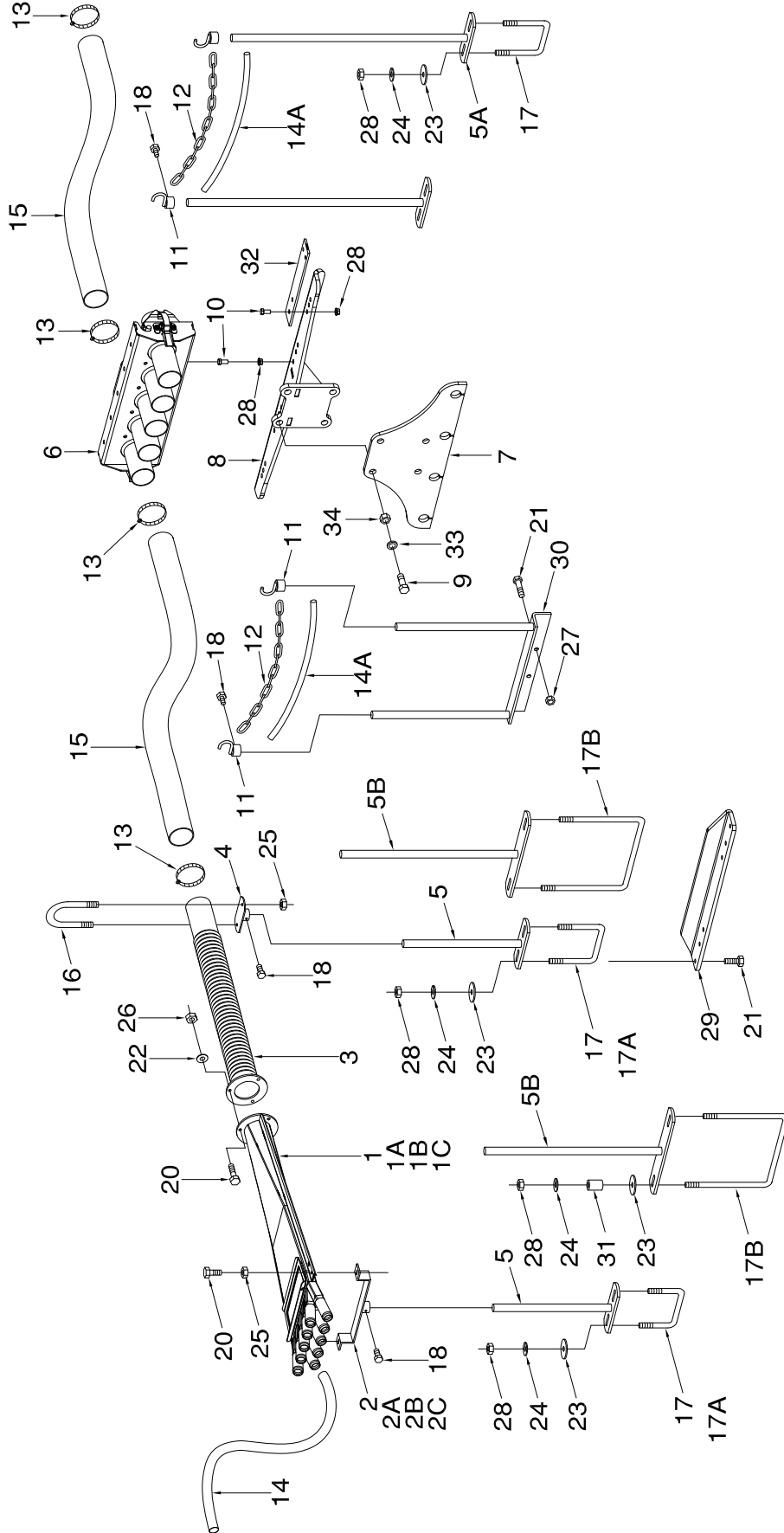

Distribution - Single Shoot Tow Behind - 25 Ft and 31 Ft

Item	Part No.	Description	No: Used			
			25 ft		31 ft	
			10	12	10	12
1	N42274	Divider Assembly - 11 Outlet	-	-	-	-
1A	N31190	Divider Assembly - 10 Outlet.....	-	-	-	-
1B	N31189	Divider Assembly - 9 Outlet.....	-	1	-	-
1C	N31188	Divider Assembly - 8 Outlet.....	2	2	1	3
1D	N31187	Divider Assembly - 7 Outlet.....	2	-	4	1
2	N40544	Support - 11 Outlet.....	-	-	-	-
2A	N19406	Support - 10 Outlet.....	-	-	-	-
2B	N15595	Support - 9 Outlet.....	-	1	-	-
2C	N15107	Support - 8 Outlet.....	2	2	1	3
2D	N15594	Support - 7 Outlet.....	2	-	4	1
3	N15135	Pipe - Corr Diff - Divider Head	4	3	5	4
4	N15102	Support - Rear	4	3	5	4
5	N15105	Support - Bottom - Rod 12".....	8	4	8	8
5A	N19531	Support - Bottom - Rod 24".....	2	2	2	2
5B	N45694	Support - Wide - Bottom - Rod 14".....	-	2	2	-
6	*****	Quick Coupler - 5 Run	1	1	1	1
7	N53930	Adaptor Plate	1	1	1	1
8	N53203	Coupler Tower - Behind	1	1	1	1
9	W-497	Bolt - 5/8 x 1 1/2 Lg.....	4	4	4	4
10	W-475	Hex Bolt - 3/8 x 1 Lg.....	4	4	4	4
11	N19717	Hook - Chain	4	4	4	4
12	N19448	Chain - 80 Link.....	2	2	2	2
13	N11905	Hose Clamp - 2 1/2.....	16	12	20	16
14	R480034	Hose - .929 ID x 1.169 OD/ft (75 ft roll)	375	300	450	375
14A	R480034	Hose - .929 ID x 1.169 OD x 1.5 ft (75 ft roll)	2	2	2	2
15	R480055	Hose - 2 1/2 ID/ft (100 ft rolls)	75	50	100	75
16	N15096	U-Bolt - 1/4 x 2.5 x 3 1/4 lg	4	3	5	4
17	N15098	U-Bolt - 3/8 x 4 x 5	6	4	6	6
17A	N15097	U-Bolt - 3/8 x 2 x 5	4	4	4	4
17B	N40715	U-Bolt - 3/8 x 8 x 9 3/4	-	2	2	-
17C	N34025	U-Bolt - 3/8 x 5 x 8	4	4	4	4
18	N24396	Setscrew - 1/4 x 1/2	12	10	14	12
19	K-3830	Hex Bolt - 1/4 x 1/2 Lg	-	-	-	-
20	W-469	Hex Bolt - 1/4 x 3/4 Lg	20	15	25	20
21	W-187	Hex Bolt - 3/8 x 1 1/4 Lg	10	6	6	10
22	W-521	Lockwasher - 1/4	12	9	15	12
23	D-5579	Flatwasher - 3/8	36	16	36	36
24	W-523	Lockwasher - 3/8.....	36	16	36	36
25	D-5277	Serrated Locknut - 1/4.....	16	12	20	16
26	W-512	Hex Nut - 1/4.....	12	9	15	12
27	D-5279	Serrated Locknut - 3/8.....	14	14	14	14
28	W-514	Hex Nut - 3/8.....	36	16	36	36
29	S44308	Extension Bracket - Head Support.....	4	2	2	4
30	N45696	Hose Support.....	1	1	1	1
31	N11750	Bushing - 0.385 ID x 0.625 OD x 1 1/16 Lg	-	4	4	-
32	N55257	Bracket - Air Cart Hydraulic Quick Coupler Mount	1	1	1	1
33	W-526	Lockwasher - 5/8.....	4	4	4	4
34	W-517	Hex Nut - 5/8.....	4	4	4	4

Distribution - 9 Series Air Cart Single Shoot Tow Behind - 41 to 51 ft

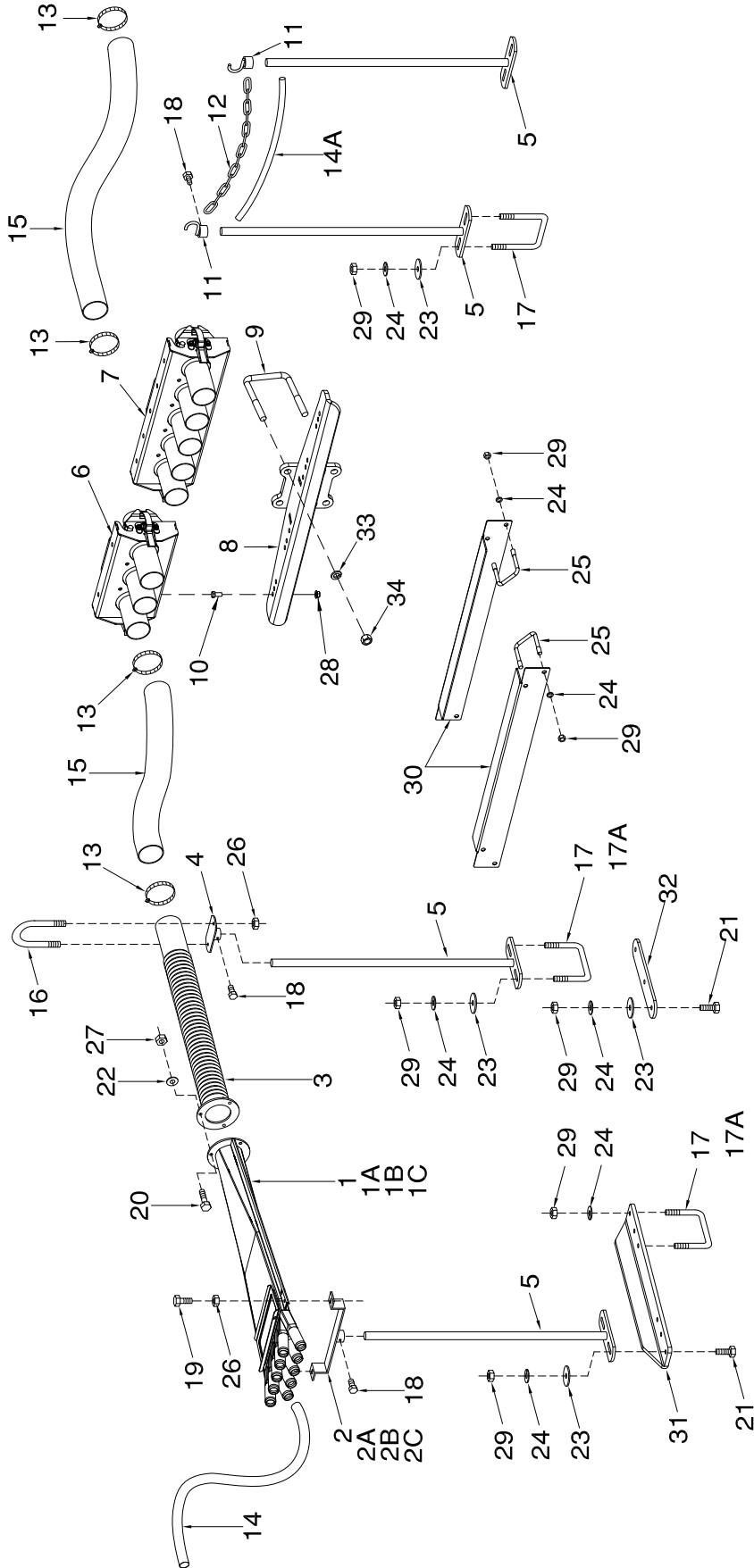

Distribution - Single Shoot Tow Behind - 41 to 51 ft

Item	Part No.	Description	No: Used			
			41 ft		51 ft	
			10	12	10	12
1	N42274	Divider Assembly - 11 Outlet	-	-	-	-
1A	N31190	Divider Assembly - 10 Outlet.....	-	-	-	-
1B	N31189	Divider Assembly - 9 Outlet.....	2	1	4	-
1C	N31188	Divider Assembly - 8 Outlet.....	4	4	3	2
1D	N31187	Divider Assembly - 7 Outlet.....	-	-	-	5
2	N40544	Support - 11 Outlet.....	-	-	-	-
2A	N19406	Support - 10 Outlet.....	2	-	-	-
2B	N15595	Support - 9 Outlet.....	4	1	4	-
2C	N15107	Support - 8 Outlet.....	-	4	3	2
2D	N15594	Support - 7 Outlet.....	-	-	-	5
3	N15135	Pipe - Corr Diff - Divider Head	6	5	7	7
4	N15102	Support - Rear	6	5	7	7
5	N19531	Support - Bottom - Rod 24".....	14	12	16	16
6	*****	Quick Coupler - 3 Run	2	2	0	0
7	*****	Quick Coupler - 5 Run	0	0	2	2
8	N53203	Coupler Tower - Behind	1	1	1	1
9	C-219	U-Bolt - 5/8 x 4 x 5 9/16 Lg	2	2	2	2
10	W-475	Hex Bolt - 3/8 x 1 Lg.....	4	4	4	4
11	N19717	Hook - Chain.....	2	2	2	2
12	N19448	Chain - 80 Link.....	1	1	1	1
13	N11905	Hose Clamp - 2 1/2.....	24	20	32	28
14	R480034	Hose - .929 ID x 1.169 OD/ft (75 ft roll)	450	450	600	600
14A	R480034	Hose - .929 ID x 1.169 OD/ft (75 ft roll)	1.5 ft	1.5 ft	1.5 ft	1.5 ft
15	R480055	Hose - 2 1/2 ID/ft (100 ft rolls)	125	100	75	75
16	N15096	U-Bolt - 1/4 x 2.5 x 3 1/4 lg	6	5	7	7
17	N15098	U-Bolt - 3/8 x 4 x 5	18	16	20	20
17A	N15097	U-Bolt - 3/8 x 2 x 5	14	12	16	16
18	N24396	Setscrew - 1/4 x 1/2 Lg	14	12	16	16
19	W-469	Hex Bolt - 1/4 x 3/4 Lg.....	12	10	14	14
20	W-469	Hex Bolt - 1/4 x 3/4 Lg.....	18	15	21	21
21	W-187	Hex Bolt - 3/8 x 1 1/4 Lg.....	0	4	4	4
22	W-521	Lockwasher - 1/4.....	18	15	21	21
23	D-5579	Flatwasher - 3/8	28	24	32	32
24	W-523	Lockwasher - 3/8.....	52	52	60	60
25	D12714	U-Bolt - 3/8.....	8	8	8	8
26	D-5277	Serrated Locknut - 1/4.....	24	20	28	28
27	W-512	Hex Nut - 1/4.....	18	15	21	21
28	D-5279	Serrated Locknut - 3/8.....	12	12	12	12
29	W-514	Hex Nut - 3/8.....	52	52	60	60
30	S44307	Support Bracket - Distribution	4	4	4	4
31	S44308	Extension Bracket - Head Support	0	2	5	5
32	S44467	Head Support Plate	0	0	4	2
33	W-526	Lockwasher - 5/8.....	4	4	4	4
34	W-517	Hex Nut - 5/8.....	4	4	4	4

Distribution - 9 Series Air Cart Single Shoot Tow Behind - 61 to 90 ft

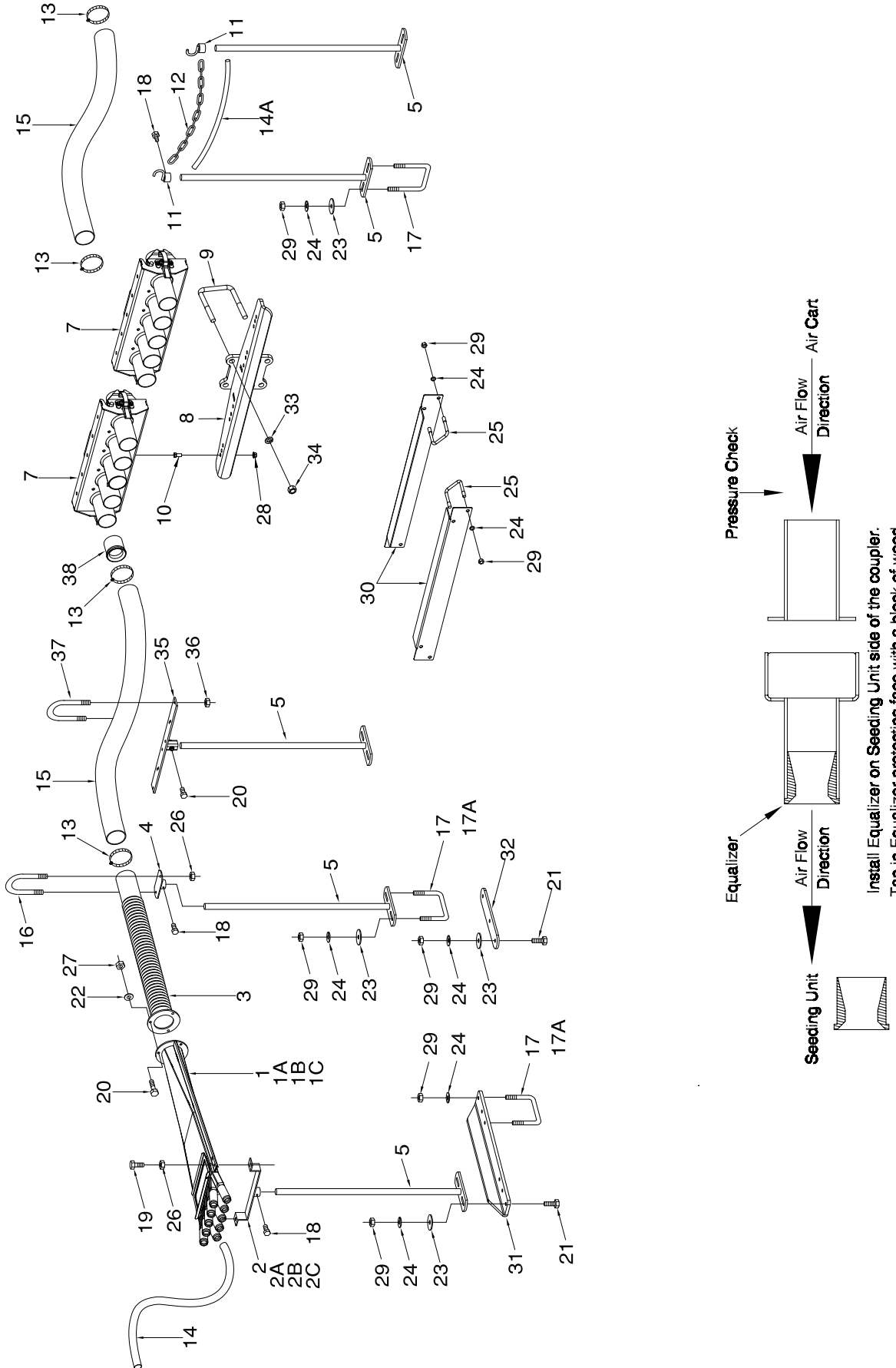

Distribution - Single Shoot Tow Behind - 61 to 90 ft

Item	Part No.	Description	No. Used						
			61 ft		71 ft		80ft	86ft	90ft
			10	12	10	12	12	12	12
1	N42274	Divider Assembly - 11 Outlet	-	-	-	-	-	-	-
1A	N31190	Divider Assembly - 10 Outlet	-	-	3	-	-	5	9
1B	N31189	Divider Assembly - 9 Outlet	-	-	6	-	8	4	-
1C	N31188	Divider Assembly - 8 Outlet	9	5	-	8	1	-	-
1D	N31187	Divider Assembly - 7 Outlet	-	3	-	1	-	-	-
2	N40544	Support - 11 Outlet	-	-	-	-	-	-	-
2A	N19406	Support - 10 Outlet	-	-	3	-	-	5	9
2B	N15595	Support - 9 Outlet	-	-	6	-	8	4	-
2C	N15107	Support - 8 Outlet	9	5	-	8	1	-	-
2D	N15594	Support - 7 Outlet	-	3	-	1	-	-	-
3	N15135	Pipe - Corr Diff - Divider Head	9	8	9	9	9	9	9
4	N15102	Support - Rear	9	8	9	9	9	9	9
5	N19531	Support - Bottom - Rod 24"	20	18	20	20	20	20	20
6	*****	Quick Coupler - 3 Run	-	-	-	-	-	-	-
7	*****	Quick Coupler - 5 Run	2	2	2	2	2	2	2
8	N53203	Coupler Tower - Behind	1	1	1	1	1	1	1
9	C-219	U-Bolt - 5/8 x 4 x 5 9/16 Lg	2	2	2	2	2	2	2
10	W-475	Hex Bolt - 3/8 x 1 Lg	4	4	4	4	4	4	4
11	N19717	Hook - Chain	2	2	2	2	2	2	2
12	N19448	Chain - 80 Link	1	1	1	1	1	1	1
13	N11905	Hose Clamp - 2 1/2	36	32	36	36	36	36	36
14	R480034	Hose - .929 ID x 1.169 OD/ft (75 ft roll)	600	525	825	750	825	825	900
14A	R480034	Hose - .929 ID x 1.169 OD/ft (75 ft roll)	1.5 ft	1.5 ft	1.5 ft	1.5 ft	1.5 ft	1.5 ft	1.5
15	R480055	Hose - 2 1/2 ID/ft (100 ft rolls)	200	175	250	250	275	275	275
16	N15096	U-Bolt - 1/4 x 2.5 x 3 1/4 Lg	9	8	9	9	9	9	9
17	N15098	U-Bolt - 3/8 x 4 x 5	24	22	24	24	24	24	24
17A	N15097	U-Bolt - 3/8 x 2 x 5	20	18	20	20	20	20	20
18	N24396	Setscrew - 1/4 x 1/2	20	18	20	20	20	20	20
19	W-469	Hex Bolt - 1/4 x 3/4 Lg	18	16	18	18	18	18	18
20	W-469	Hex Bolt - 1/4 x 3/4 Lg	27	24	27	27	27	27	27
21	W-187	Hex Bolt - 3/8 x 1 1/4 Lg	15	6	15	15	15	15	15
22	W-521	Lockwasher - 1/4	27	24	27	27	27	27	27
23	D-5579	Flatwasher - 3/8	40	36	40	40	40	40	40
24	W-523	Lockwasher - 3/8	79	66	79	79	79	79	79
25	D12714	U-Bolt - 3/8	8	8	8	8	8	8	8
26	D-5277	Serrated Locknut - 1/4	36	32	36	36	36	36	36
27	W-512	Hex Nut - 1/4	27	24	27	27	27	27	27
28	D-5279	Serrated Locknut - 3/8	12	12	12	12	12	12	12
29	W-514	Hex Nut - 3/8	79	66	79	79	79	79	79
30	S44307	Support Bracket - Distribution	4	4	4	4	4	4	4
31	S44308	Extension Bracket - Head Support	2	4	9	7	7	7	7
32	S44467	Head Support Plate	2	2	3	3	1	1	1
33	W-526	Lockwasher - 5/8	4	4	4	4	4	4	4
34	W-517	Hex Nut - 5/8	4	4	4	4	4	4	4
35	N48297	Hose Support - 80 & 90	0	0	0	0	2	2	2
36	N22778	Locknut - 1/4 nylon insert	0	0	0	0	16	16	16
37	N37630	U-Bolt - 1/4 x 2 3/4 x 3 3/4	0	0	0	0	8	8	8
38	N37920	Equalizer	7	5	3	3	5	5	5

Distribution - 9 Series Air Cart Single Shot Tow Between - 25 Ft and 31 Ft

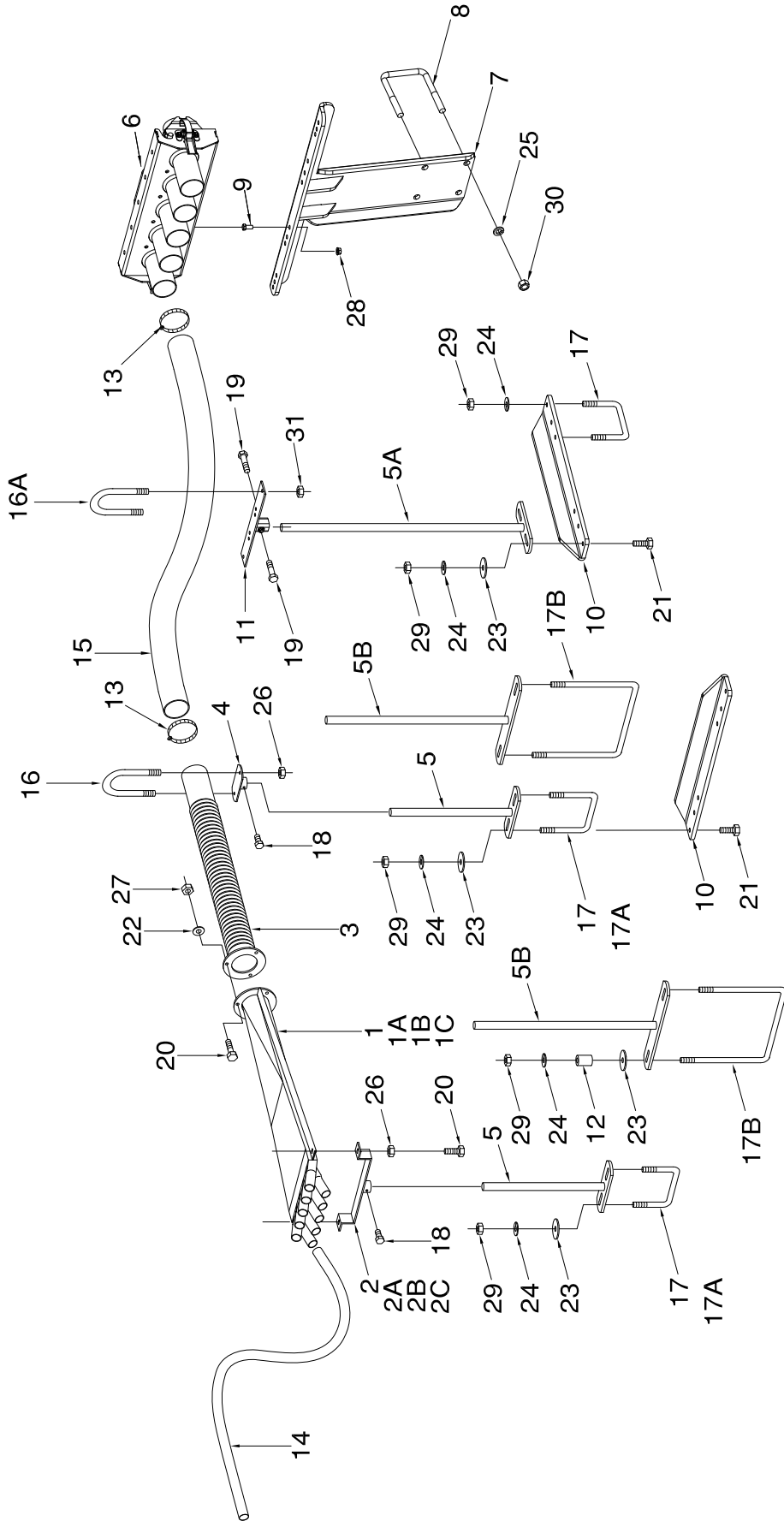

Distribtion - Single Shoot Tow Between - 25 Ft and 31 Ft

Item	Part No.	Description	No: Used			
			25 ft		31 ft	
			10	12	10	12
1	N42274	Divider Assembly - 11 Outlet	-	-	-	-
1A	N31190	Divider Assembly - 10 Outlet.....	-	-	-	-
1B	N31189	Divider Assembly - 9 Outlet.....	-	1	-	-
1C	N31188	Divider Assembly - 8 Outlet.....	2	2	1	3
1D	N31187	Divider Assembly - 7 Outlet.....	2	-	4	1
2	N40544	Support - 11 Outlet.....	-	-	-	-
2A	N19406	Support - 10 Outlet.....	-	-	-	-
2B	N15595	Support - 9 Outlet.....	-	1	-	-
2C	N15107	Support - 8 Outlet.....	2	2	1	3
2D	N15594	Support - 7 Outlet.....	2	-	4	1
3	N15135	Pipe - Corr Diff - Divider Head	4	3	5	4
4	N15102	Support - Rear	4	3	5	4
5	N15105	Support - Bottom - Rod 12".....	8	4	8	8
5A	N19531	Support - Bottom - Rod 24".....	2	2	2	2
5B	N45694	Support - Wide - Bottom - Rod 14".....	-	2	2	-
6	*****	Quick Coupler - 5 Run	1	1	1	1
7	N51962	Coupler Tower - Between - Short.....	1	1	1	1
8	C-219	U-Bolt - 5/8 x 4 x 5 9/16 Lg	2	2	2	2
9	W-867	Hex Bolt - 3/8 x 3/4 Lg.....	2	2	2	2
10	S44308	Extension Bracket - Head Support.....	4	2	2	4
11	N40704	Support - Hose.....	2	2	2	2
12	N11750	Bushing - 0.385 ID x 0.625 OD x 1 1/16 Lg	-	4	4	-
13	N11905	Hose Clamp - 2 1/2.....	16	12	20	16
14	R480034	Hose - .929 ID x 1.169 OD/ft (75 ft roll)	375	300	450	375
15	R480055	Hose - 2 1/2 ID/ft (100 ft rolls)	75	50	100	75
16	N15096	U-Bolt - 1/4 x 2.5 x 3 1/4 lg	4	3	5	4
16A	N37630	U-Bolt - 1/4 x 2 3/4 x 3 3/4 Lg	4	2	4	4
17	N15098	U-Bolt - 3/8 x 4 x 5	6	4	6	6
17A	N15097	U-Bolt - 3/8 x 2 x 5	4	2	4	4
17B	N40715	U-Bolt - 3/8 x 8 x 9 3/4	-	2	2	-
18	N24396	Setscrew - 1/4 x 1/2	10	8	12	10
19	K-3830	Hex Bolt - 1/4 x 1/2 Lg	4	4	4	4
20	W-469	Hex Bolt - 1/4 x 3/4 Lg	20	15	25	20
21	W-187	Hex Bolt - 3/8 x 1 1/4 Lg	8	4	4	8
22	W-521	Lockwasher - 1/4	12	9	15	12
23	D-5579	Flatwasher - 3/8	20	16	24	20
24	W-523	Lockwasher - 3/8.....	28	24	28	28
25	W-526	Lockwasher - 5/8.....	4	4	4	4
26	D-5277	Serrated Locknut - 1/4.....	16	12	20	16
27	W-512	Hex Nut - 1/4.....	12	9	15	12
28	D-5279	Serrated Locknut - 3/8.....	6	6	6	6
29	W-514	Hex Nut - 3/8.....	28	20	28	28
30	W-517	Hex Nut - 5/8.....	4	4	4	4
31	N22778	Locknut Nylon Insert - 1/4	8	8	8	8

**Distribution - 9 Series Air Cart
Single Shoot Tow Between - 41 to 51 ft**

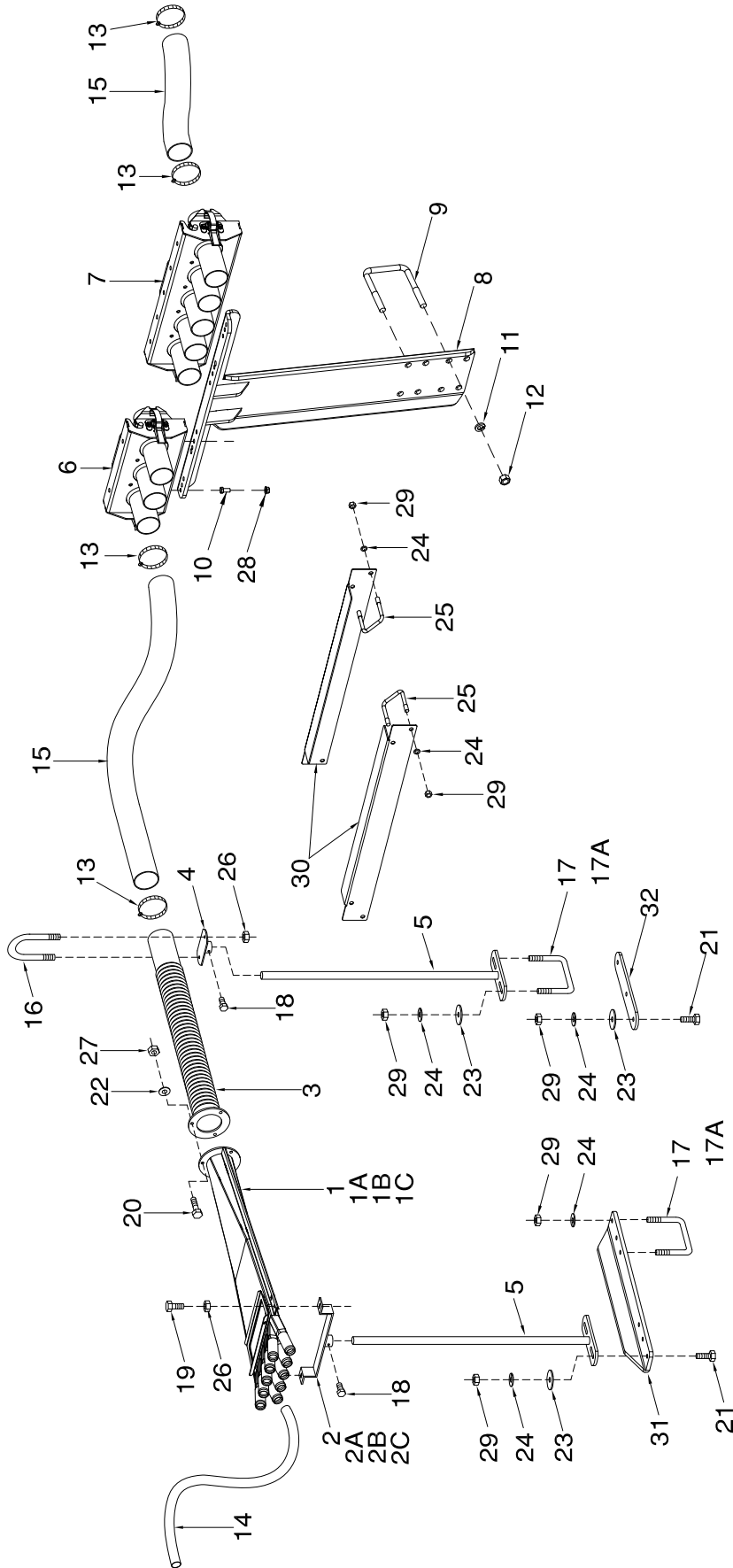

Distribtion - Single Shoot Tow Between - 41 to 51 ft

Item	Part No.	Description	No: Used			
			41 ft		51 ft	
			10	12	10	12
1	N42274	Divider Assembly - 11 Outlet	-	-	-	-
1A	N31190	Divider Assembly - 10 Outlet.....	-	-	-	-
1B	N31189	Divider Assembly - 9 Outlet.....	2	1	4	-
1C	N31188	Divider Assembly - 8 Outlet.....	4	4	3	2
1D	N31187	Divider Assembly - 7 Outlet.....	-	-	-	5
2	N40544	Support - 11 Outlet.....	-	-	-	-
2A	N19406	Support - 10 Outlet.....	2	-	-	-
2B	N15595	Support - 9 Outlet.....	4	1	4	-
2C	N15107	Support - 8 Outlet.....	-	4	3	2
2D	N15594	Support - 7 Outlet.....	-	-	-	5
3	N15135	Pipe - Corr Diff - Divider Head	6	5	7	7
4	N15102	Support - Rear	6	5	7	7
5	N19531	Support - Bottom - Rod 24".....	14	12	16	16
6	*****	Quick Coupler - 3 Run	2	2	0	0
7	*****	Quick Coupler - 5 Run	0	0	2	2
8	N51967	Coupler Tower - Between - Tall	1	1	1	1
9	C-219	U-Bolt - 5/8 x 4 x 5 9/16 Lg	2	2	2	2
10	W-867	Hex Bolt - 3/8 x 3/4 Lg.....	4	4	4	4
11	W-526	Lockwasher - 5/8.....	4	4	4	4
12	W-517	Hex Nut - 5/8.....	4	4	4	4
13	N11905	Hose Clamp - 2 1/2	24	20	28	28
14	R480034	Hose - .929 ID x 1.169 OD/ft (75 ft roll)	450	450	600	600
15	R480055	Hose - 2 1/2 ID/ft (100 ft rolls)	125	100	100	100
16	N15096	U-Bolt - 1/4 x 2 1/2 x 3 1/4 lg	6	5	7	7
17	N15098	U-Bolt - 3/8 x 4 x 5	18	16	20	20
17A	N15097	U-Bolt - 3/8 x 2 x 5	14	12	16	16
18	N24396	Setscrew - 1/4 x 1/2	14	12	16	16
19	K-3830	Hex Bolt - 1/4 x 1/2 Lg.....	12	10	14	14
20	W-469	Hex Bolt - 1/4 x 3/4 Lg.....	18	15	21	21
21	W-187	Hex Bolt - 3/8 x 1 1/4 Lg.....	0	4	4	4
22	W-521	Lockwasher - 1/4.....	18	15	21	21
23	D-5579	Flatwasher - 3/8	28	24	32	32
24	W-523	Lockwasher - 3/8.....	52	52	60	60
25	D12714	U-Bolt - 3/8.....	8	8	8	8
26	D-5277	Serrated Locknut - 1/4.....	24	20	28	28
27	W-512	Hex Nut - 1/4.....	18	15	21	21
28	D-5279	Serrated Locknut - 3/8.....	12	12	12	12
29	W-514	Hex Nut - 3/8.....	52	52	60	60
30	S44307	Support Bracket - Distribution	4	4	4	4
31	S44308	Extension Bracket - Head Support.....	0	2	0	0
32	S44467	Head Support Plate	0	0	0	0

Distribution - 9 Series Air Cart Single Shoot Tow Between - 61 to 90 ft

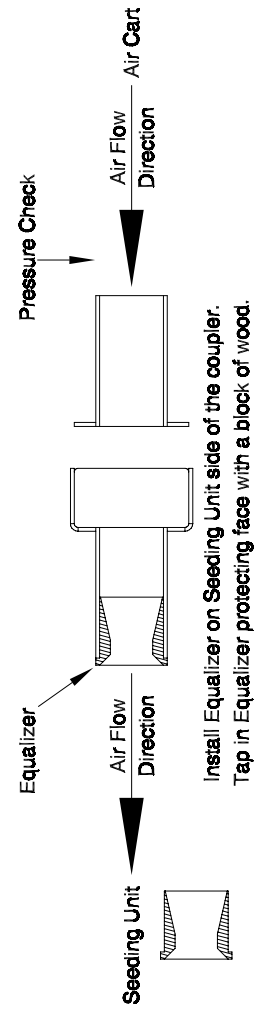
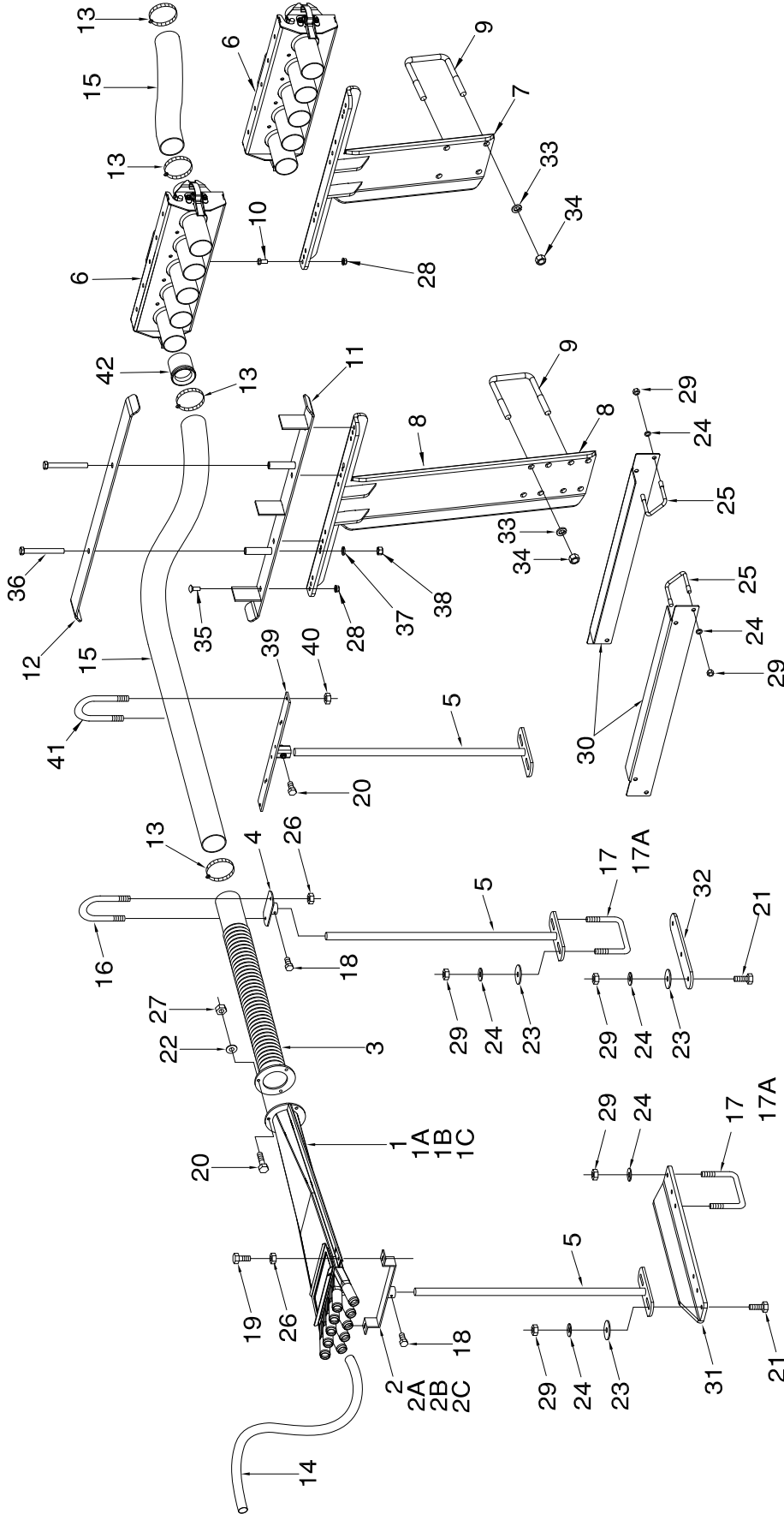

Distribtion - Single Shoot Tow Between - 61 to 90 ft

Item	Part No.	Description	No. Used						
			61 ft		71 ft		80ft	86ft	90ft
			10	12	10	12	12	12	12
1	N42274	Divider Assembly - 11 Outlet	-	-	-	-	-	-	-
1A	N31190	Divider Assembly - 10 Outlet	-	-	3	-	-	5	9
1B	N31189	Divider Assembly - 9 Outlet	-	-	6	-	8	4	-
1C	N31188	Divider Assembly - 8 Outlet	9	5	-	8	1	-	-
1D	N31187	Divider Assembly - 7 Outlet	-	3	-	1	-	-	-
2	N40544	Support - 11 Outlet	-	-	-	-	-	-	-
2A	N19406	Support - 10 Outlet	-	-	3	-	-	5	9
2B	N15595	Support - 9 Outlet	-	-	6	-	8	4	-
2C	N15107	Support - 8 Outlet	9	5	-	8	1	-	-
2D	N15594	Support - 7 Outlet	-	3	-	1	-	-	-
3	N15135	Pipe - Corr Diff - Divider Head	9	8	9	9	9	9	9
4	N15102	Support - Rear	9	8	9	9	9	9	9
5	N19531	Support - Bottom - Rod 24"	20	18	20	20	20	20	20
6	*****	Quick Coupler - 5 Run	2	2	2	2	2	2	2
7	N51962	Coupler Tower - Between - Short	1	1	1	1	1	1	1
8	N51967	Coupler Tower - Between - Tall	1	1	1	1	1	1	1
9	C-219	U-Bolt - 5/8 x 4 x 5 9/16 Lg	2	2	2	2	2	2	2
10	W-867	Hex Bolt - 3/8 x 3/4 Lg	4	4	4	4	4	4	4
11	N51979	Hose Clamp Strap	1	1	1	1	1	1	1
12	N51977	Clamp Plate	1	1	1	1	1	1	1
13	N11905	Hose Clamp - 2 1/2	36	28	36	36	36	36	36
14	R480034	Hose - .929 ID x 1.169 OD/ft (75 ft roll)	750	525	825	750	825	825	900
15	R480055	Hose - 2 1/2 ID/ft (100 ft rolls)	250	225	300	300	325	325	325
16	N15096	U Bolt 1/4 x 2 1/2 x 3 1/4 lg	9	8	9	9	9	9	9
17	N15098	U-Bolt - 3/8 x 4 x 5	24	22	24	24	24	24	24
17A	N15097	U-Bolt - 3/8 x 2 x 5	20	18	20	20	20	20	20
18	N24396	Setscrew - 1/4 x 1/2	20	18	20	20	20	20	20
19	K-3830	Hex Bolt - 1/4 x 1/2 Lg	18	16	18	18	18	18	18
20	W-469	Hex Bolt - 1/4 x 3/4 Lg	27	24	27	27	27	27	27
21	W-187	Hex Bolt - 3/8 x 1 1/4 Lg	15	6	15	15	15	15	15
22	W-521	Lockwasher - 1/4	27	24	27	27	27	27	27
23	D-5579	Flatwasher - 3/8	40	36	40	40	40	40	40
24	W-523	Lockwasher - 3/8	79	66	79	79	79	79	79
25	D12714	U-Bolt - 3/8	8	8	8	8	8	8	8
26	D-5277	Serrated Locknut - 1/4	36	32	36	36	36	36	36
27	W-512	Hex Nut - 1/4	27	24	27	27	27	27	27
28	D-5279	Serrated Locknut - 3/8	12	12	12	12	12	12	12
29	W-514	Hex Nut - 3/8	79	66	79	79	79	79	79
30	S44307	Support Bracket - Distribution	4	4	4	4	4	4	4
31	S44308	Extension Bracket - Head Support	0	4	7	7	7	7	7
32	S44467	Head Support Plate	2	2	1	1	1	1	1
33	W-526	Lockwasher - 5/8	4	4	4	4	4	4	4
34	W-517	Hex Nut - 5/8	4	4	4	4	4	4	4
35	P7C616	Carriage Bolt - 3/8 x 1	4	4	4	4	4	4	4
36	C-3684	Hex Bolt - 1/2 x 4 1/2 Lg	2	2	2	2	2	2	2
37	W-525	Lockwasher - 1/2	2	2	2	2	2	2	2
38	W-516	Hex Nut - 1/2	2	2	2	2	2	2	2
39	N48297	Hose Support - 80 & 86	0	0	0	0	2	2	2
40	N22778	Locknut - 1/4 nylon insert	0	0	0	0	16	16	16
41	N37630	U-Bolt - 1/4 x 2 3/4 x 3 3/4	0	0	0	0	8	8	8
42	N37920	Equalizer	7	5	3	3	5	5	5

Distribution - 9 Series Air Cart Dual Shot Tow Behind - 25 Ft and 31 Ft

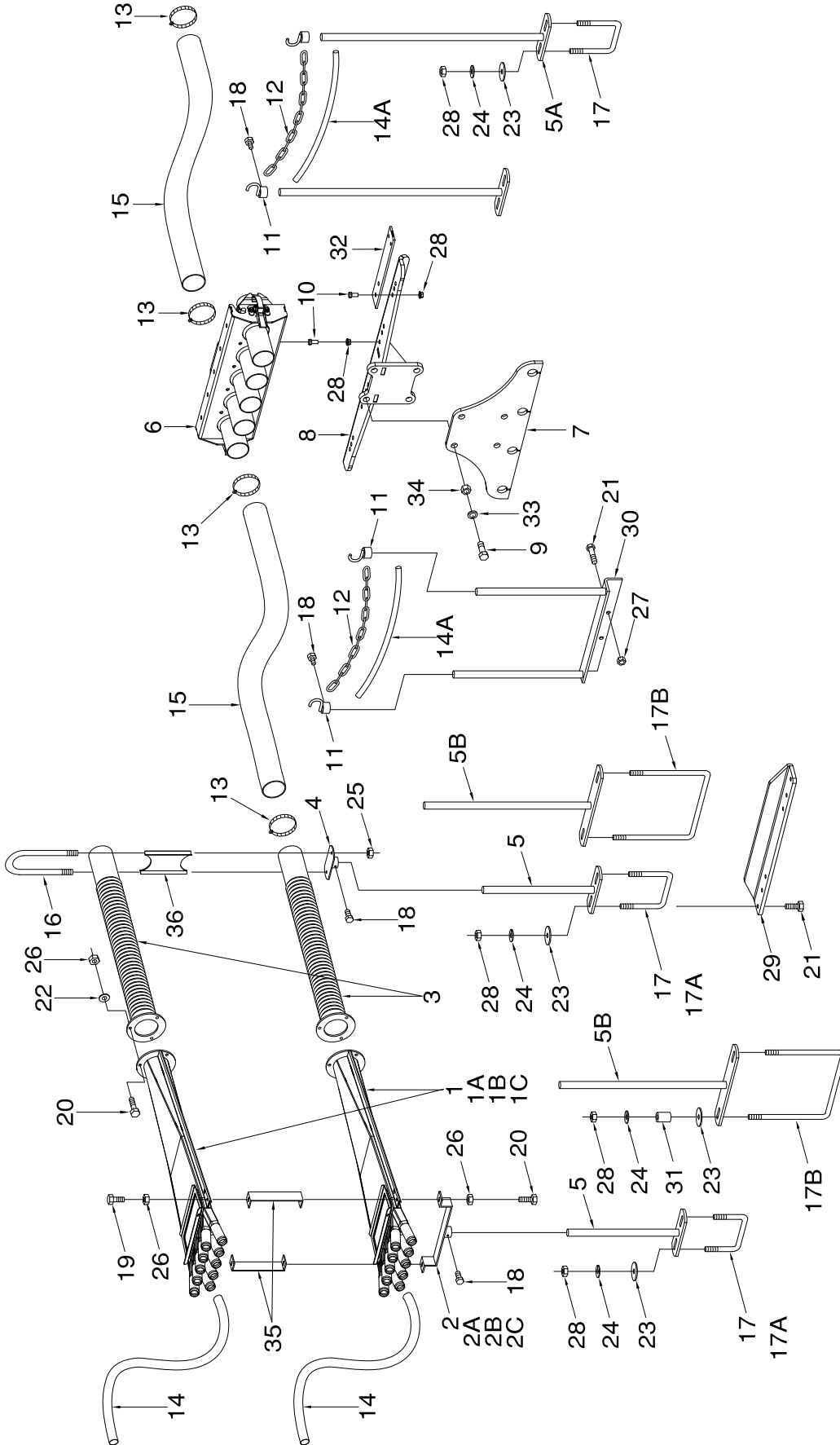

Distribution - Dual Shoot Tow Behind - 25 Ft and 31 Ft

Item	Part No.	Description	No: Used			
			25 ft		31 ft	
			10	12	10	12
1	N42274	Divider Assembly - 11 Outlet	-	-	-	-
1A	N31190	Divider Assembly - 10 Outlet.....	-	-	-	-
1B	N31189	Divider Assembly - 9 Outlet.....	-	2	-	-
1C	N31188	Divider Assembly - 8 Outlet.....	4	4	2	6
1D	N31187	Divider Assembly - 7 Outlet.....	4	-	8	2
2	N40544	Support - 11 Outlet.....	-	-	-	-
2A	N19406	Support - 10 Outlet.....	-	-	-	-
2B	N15595	Support - 9 Outlet.....	-	1	-	-
2C	N15107	Support - 8 Outlet.....	2	2	1	3
2D	N15594	Support - 7 Outlet.....	2	-	4	1
3	N15135	Pipe - Corr Diff - Divider Head	8	6	10	8
4	N15102	Support - Rear	4	3	5	4
5	N15105	Support - Bottom - Rod 12".....	8	6	8	8
5A	N19531	Support - Bottom - Rod 24".....	2	2	2	2
5B	N45694	Support - Wide - Bottom - Rod 14".....	-	2	2	-
6	*****	Quick Coupler - 5 Run	2	2	2	2
7	N53930	Adaptor Plate	1	1	1	1
8	N53203	Coupler Tower - Behind	1	1	1	1
9	W-497	Bolt - 5/8 x 1 1/2 Lg.....	4	4	4	4
10	W-867	Hex Bolt - 3/8 x 3/4 Lg.....	4	4	4	4
11	N19717	Hook - Chain	4	4	4	4
12	N19448	Chain - 80 Link.....	2	2	2	2
13	N11905	Hose Clamp - 2 1/2.....	32	24	40	32
14	R480034	Hose - .929 ID x 1.169 OD/ft (75 ft roll)	675	600	825	675
14A	R480034	Hose - .929 ID x 1.169 OD x 1.5 ft (75 ft roll)	2	2	2	2
15	R480055	Hose - 2 1/2 ID/ft (100 ft rolls)	150	100	200	150
16	N16504	U-Bolt - 1/4 x 2 9/16 x 9 1/2 Lg	4	3	5	4
17	N15098	U-Bolt - 3/8 x 4 x 5	6	4	6	6
17A	N15097	U-Bolt - 3/8 x 2 x 5	4	2	4	4
17B	N40715	U-Bolt - 3/8 x 8 x 9 3/4	-	2	2	-
17C	N34025	U-Bolt - 3/8 x 5 x 8	4	4	4	4
18	N24396	Setscrew - 1/4 x 1/2	12	10	14	12
19	K-3830	Hex Bolt - 1/4 x 1/2 Lg	8	6	10	8
20	W-469	Hex Bolt - 1/4 x 3/4 Lg	32	27	40	32
21	W-187	Hex Bolt - 3/8 x 1 1/4 Lg	10	6	6	10
22	W-521	Lockwasher - 1/4	24	18	30	24
23	D-5579	Flatwasher - 3/8	36	32	36	36
24	W-523	Lockwasher - 3/8.....	36	32	36	36
25	D-5277	Serrated Locknut - 1/4.....	24	20	30	24
26	W-512	Hex Nut - 1/4.....	24	18	30	24
27	D-5279	Serrated Locknut - 3/8.....	26	26	26	26
28	W-514	Hex Nut - 3/8.....	36	32	36	36
29	S44308	Extension Bracket - Head Support.....	4	2	2	4
30	N45696	Hose Support.....	1	1	1	1
31	N11750	Bushing - 0.385 ID x 0.625 OD x 1 1/16 Lg	-	4	4	-
32	N55257	Bracket - Air Cart Hydraulic Quick Coupler Mount	1	1	1	1
33	W-526	Lockwasher - 5/8.....	4	4	4	4
34	W-517	Hex Nut - 5/8.....	4	4	4	4
35	N16689	Bracket Front - Dual Shoot Heads.....	8	6	10	8
36	N16507	Spacer - Rear - Dual Shoot Heads	4	3	5	4

Distribution - 9 Series Air Cart Dual Shoot Tow Behind - 41 to 51 ft

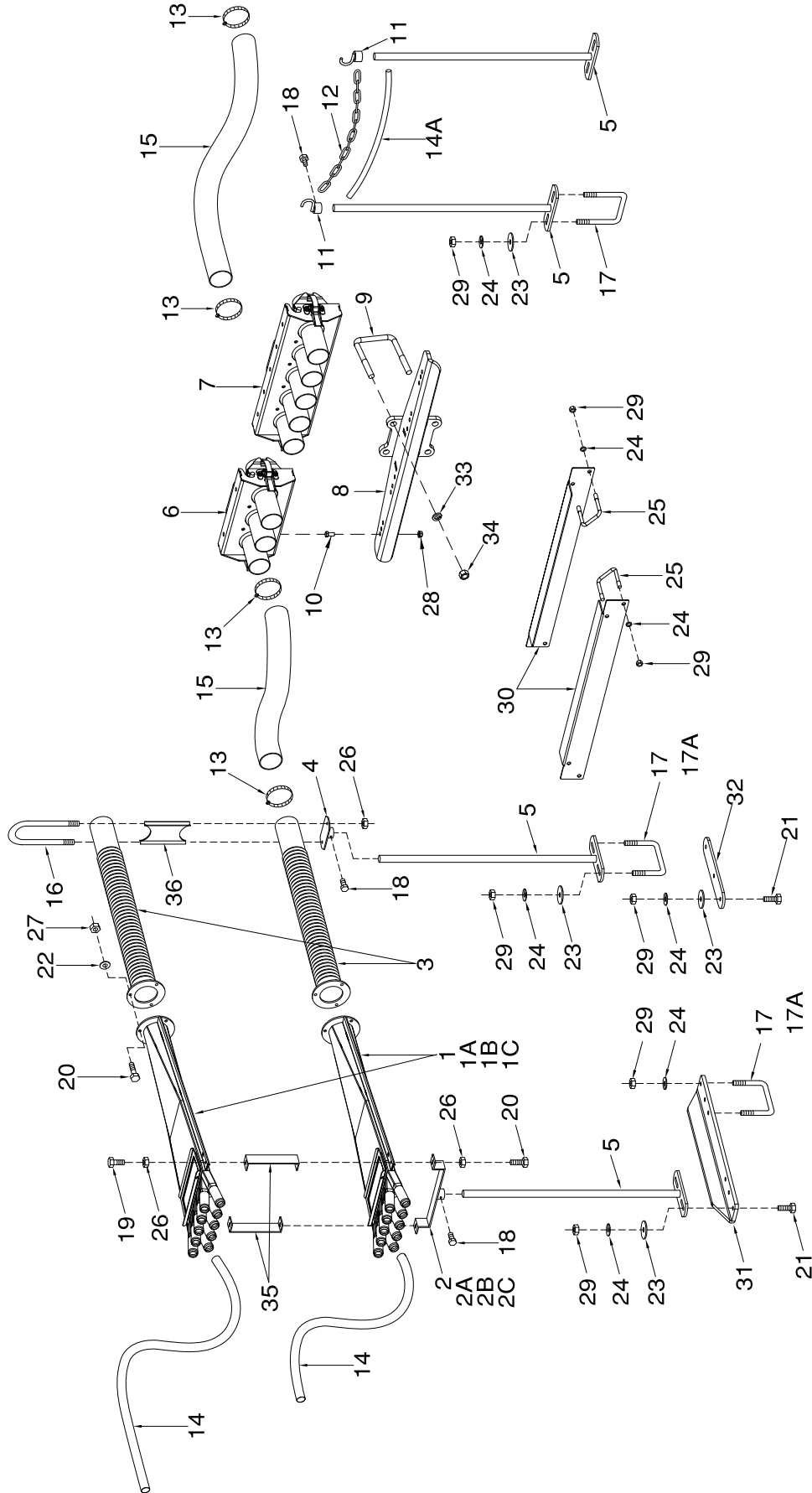

Distribution - Dual Shoot Tow Behind - 41 to 51 ft

Item	Part No.	Description	No: Used			
			41 ft		51 ft	
			10	12	10	12
1	N42274	Divider Assembly - 11 Outlet	-	-	-	-
1A	N31190	Divider Assembly - 10 Outlet.....	-	-	-	-
1B	N31189	Divider Assembly - 9 Outlet.....	4	2	8	-
1C	N31188	Divider Assembly - 8 Outlet.....	8	8	6	4
1D	N31187	Divider Assembly - 7 Outlet.....	-	-	-	10
2	N40544	Support - 11 Outlet.....	-	-	-	-
2A	N19406	Support - 10 Outlet.....	4	-	-	-
2B	N15595	Support - 9 Outlet.....	8	2	8	-
2C	N15107	Support - 8 Outlet.....	-	8	6	4
2D	N15594	Support - 7 Outlet.....	-	-	-	10
3	N15135	Pipe - Corr Diff - Divider Head	12	10	14	14
4	N15102	Support - Rear	6	5	7	7
5	N19531	Support - Bottom - Rod 24".....	14	12	16	16
6	*****	Quick Coupler - 3 Run	4	4	0	0
7	*****	Quick Coupler - 5 Run	0	0	4	4
8	N53203	Coupler Tower - Behind	1	1	1	1
9	C-219	U-Bolt - 5/8 x 4 x 5 9/16 Lg	2	2	2	2
10	W-867	Hex Bolt - 3/8 x 3/4 Lg.....	8	8	8	8
11	N19717	Hook - Chain.....	2	2	2	2
12	N19448	Chain - 80 Link.....	1	1	1	1
13	N11905	Hose Clamp - 2 1/2.....	48	40	64	56
14	R480034	Hose - .929 ID x 1.169 OD/ft (75 ft roll)	900	900	1200	1200
14A	R480034	Hose - .929 ID x 1.169 OD/ft (75 ft roll)	1.5 ft	1.5 ft	1.5 ft	1.5 ft
15	R480055	Hose - 2 1/2 ID/ft (100 ft rolls)	250	200	150	150
16	N16504	U-Bolt - 1/4 x 2 9/16 x 9 1/2 Lg	6	5	7	7
17	N15098	U-Bolt - 3/8 x 4 x 5	18	16	20	20
17A	N15097	U-Bolt - 3/8 x 2 x 5	14	12	16	16
18	N24396	Setscrew - 1/4 x 1/2	14	12	16	16
19	K-3830	Hex Bolt - 1/4 x 1/2 Lg.....	12	10	14	14
20	W-469	Hex Bolt - 1/4 x 3/4 Lg.....	38	32	44	44
21	W-187	Hex Bolt - 3/8 x 1 1/4 Lg.....	0	4	4	4
22	W-521	Lockwasher - 1/4.....	36	30	42	42
23	D-5579	Flatwasher - 3/8	28	24	32	32
24	W-523	Lockwasher - 3/8.....	52	52	60	60
25	D12714	U-Bolt - 3/8.....	8	8	8	8
26	D-5277	Serrated Locknut - 1/4.....	24	20	28	28
27	W-512	Hex Nut - 1/4.....	36	30	42	42
28	D-5279	Serrated Locknut - 3/8.....	12	12	12	12
29	W-514	Hex Nut - 3/8.....	52	52	60	60
30	S44307	Support Bracket - Distribution	4	4	4	4
31	S44308	Extension Bracket - Head Support.....	0	2	4	4
32	S44467	Head Support Plate	0	0	4	2
33	W-526	Lockwasher - 5/8.....	4	4	4	4
34	W-517	Hex Nut - 5/8.....	4	4	4	4
35	N16689	Bracket Front - Dual Shoot Heads.....	12	10	16	14
36	N16507	Spacer - Rear - Dual Shoot Heads	6	5	8	7

Distribution - 9 Series Air Cart Dual Shot Tow Behind - 61 to 90 ft

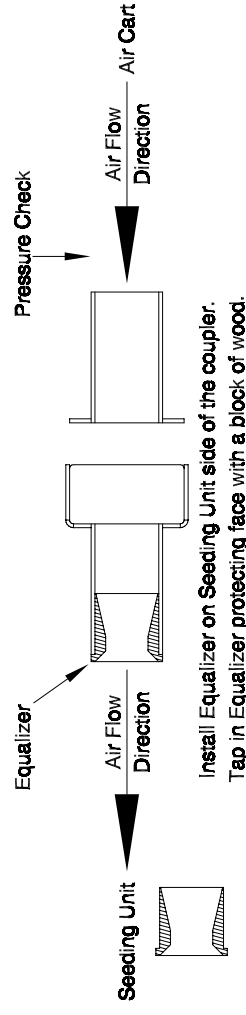
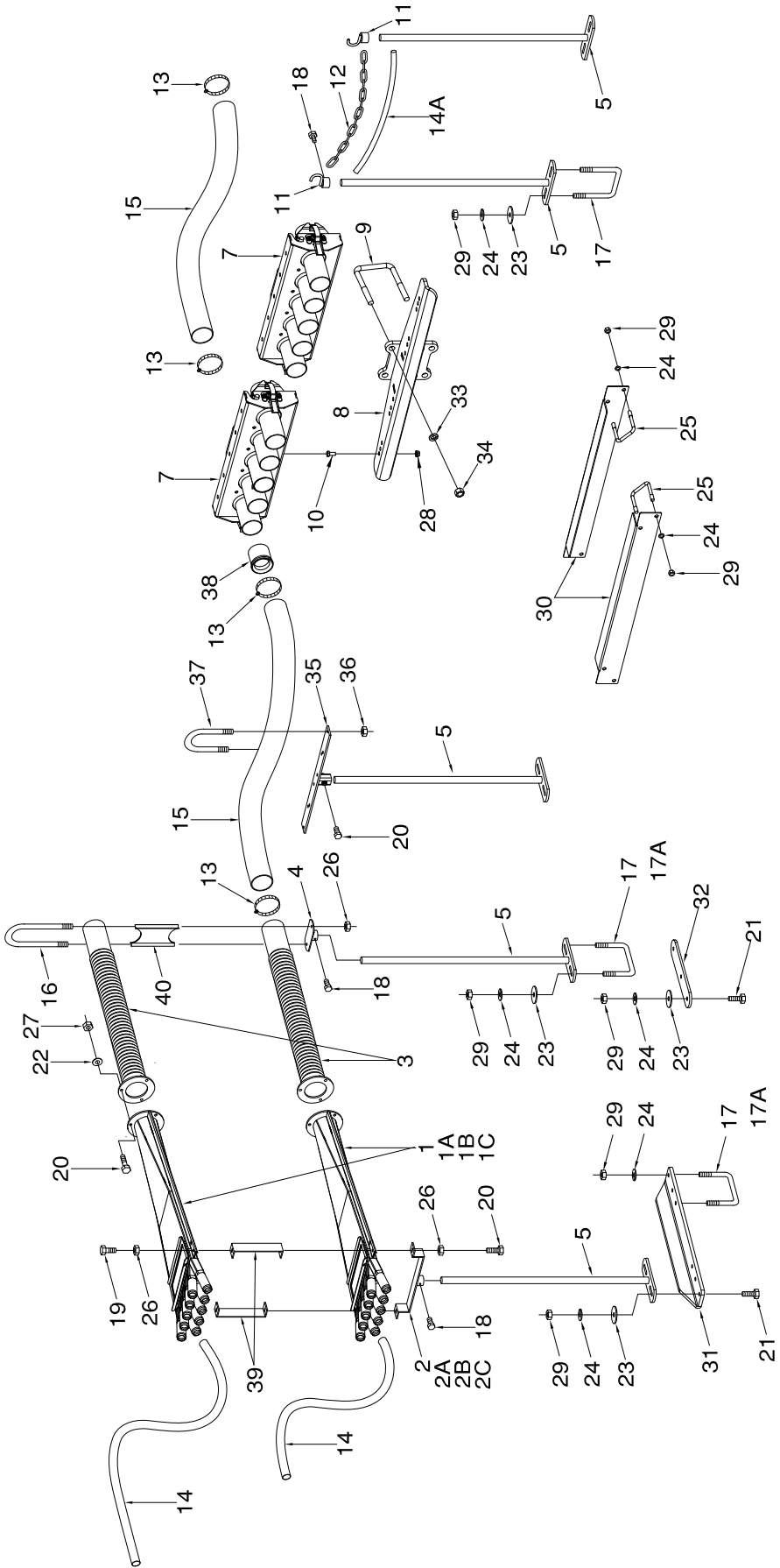

Install Equalizer on Seeding Unit side of the coupler.
Tap in Equalizer protecting face with a block of wood.

Distribution - Dual Shoot Tow Behind - 61 to 90 ft

Item	Part No.	Description	No. Used						
			61 ft		71 ft		80ft	86ft	90ft
			10	12	10	12	12	12	12
1	N42274	Divider Assembly - 11 Outlet	-	-	-	-	-	-	-
1A	N31190	Divider Assembly - 10 Outlet	-	-	6	-	-	10	18
1B	N31189	Divider Assembly - 9 Outlet	-	-	12	-	16	8	-
1C	N31188	Divider Assembly - 8 Outlet	18	10	-	16	2	-	-
1D	N31187	Divider Assembly - 7 Outlet	-	6	-	2	-	-	-
2	N40544	Support - 11 Outlet	-	-	-	-	-	-	-
2A	N19406	Support - 10 Outlet	-	-	6	-	-	10	18
2B	N15595	Support - 9 Outlet	-	-	12	-	16	8	-
2C	N15107	Support - 8 Outlet	18	10	-	16	2	-	-
2D	N15594	Support - 7 Outlet	-	6	-	2	-	-	-
3	N15135	Pipe - Corr Diff - Divider Head	16	14	18	18	18	18	18
4	N15102	Support - Rear	9	8	9	9	9	9	9
5	N19531	Support - Bottom - Rod 24"	20	18	20	20	20	20	20
6	*****	Quick Coupler - 3 Run	-	-	-	-	-	-	-
7	*****	Quick Coupler - 5 Run	2	2	2	2	2	2	2
8	N53203	Coupler Tower - Behind	1	1	1	1	1	1	1
9	C-219	U-Bolt - 5/8 x 4 x 5 9/16 Lg	2	2	2	2	2	2	2
10	W-475	Hex Bolt - 3/8 x 1 Lg	8	8	8	8	8	8	8
11	N19717	Hook - Chain	2	2	2	2	2	2	2
12	N19448	Chain - 80 Link	1	1	1	1	1	1	1
13	N11905	Hose Clamp - 2 1/2	72	64	72	72	72	72	72
14	R480034	Hose - .929 ID x 1.169 OD/ft (75 ft roll)	1500	1050	1650	1500	1650	1650	1800
14A	R480034	Hose - .929 ID x 1.169 OD/ft (75 ft roll)	1.5 ft	1.5 ft	1.5 ft	1.5 ft	1.5 ft	1.5 ft	1.5
15	R480055	Hose - 2 1/2 ID/ft (100 ft rolls)	450	400	550	550	550	550	550
16	N16504	U-Bolt - 1/4 x 2 9/16 x 9 1/2 Lg	9	8	9	9	9	9	9
17	N15098	U-Bolt - 3/8 x 4 x 5	24	22	24	24	24	24	24
17A	N15097	U-Bolt - 3/8 x 2 x 5	20	18	20	20	20	20	20
18	N24396	Setscrew - 1/4 x 1/2	20	18	20	20	20	20	20
19	W-469	Hex Bolt - 1/4 x 3/4 Lg	18	16	18	18	18	18	18
20	W-469	Hex Bolt - 1/4 x 3/4 Lg	54	48	54	54	54	54	54
21	W-187	Hex Bolt - 3/8 x 1 1/4 Lg	15	6	15	15	15	15	15
22	W-521	Lockwasher - 1/4	54	48	54	54	54	54	54
23	D-5579	Flatwasher - 3/8	40	36	40	40	40	40	40
24	W-523	Lockwasher - 3/8	79	66	79	79	79	79	79
25	D12714	U-Bolt - 3/8	8	8	8	8	8	8	8
26	D-5277	Serrated Locknut - 1/4	54	48	54	54	54	54	54
27	W-512	Hex Nut - 1/4	54	48	54	54	54	54	54
28	D-5279	Serrated Locknut - 3/8	12	12	12	12	12	12	12
29	W-514	Hex Nut - 3/8	79	66	79	79	79	79	79
30	S44307	Support Bracket - Distribution	4	4	4	4	4	4	4
31	S44308	Extension Bracket - Head Support	2	4	9	7	7	7	7
32	S44467	Head Support Plate	2	2	3	3	1	1	1
33	W-526	Lockwasher - 5/8	4	4	4	4	4	4	4
34	W-517	Hex Nut - 5/8	4	4	4	4	4	4	4
35	N48297	Hose Support - 80 & 90	0	0	0	0	2	2	2
36	N22778	Locknut - 1/4 nylon insert	0	0	0	0	16	16	16
37	N37630	U-Bolt - 1/4 x 2 3/4 x 3 3/4	0	0	0	0	8	8	8
38	N37920	Equalizer	14	10	6	6	10	10	10
39	N16689	Bracket Front - Dual Shoot Heads	18	16	18	18	18	18	18
40	N16507	Spacer - Rear - Dual Shoot Heads	9	8	9	9	9	9	9

Distribution - 9 Series Air Cart Dual Shot Tow Behind - 80 ft - 2021

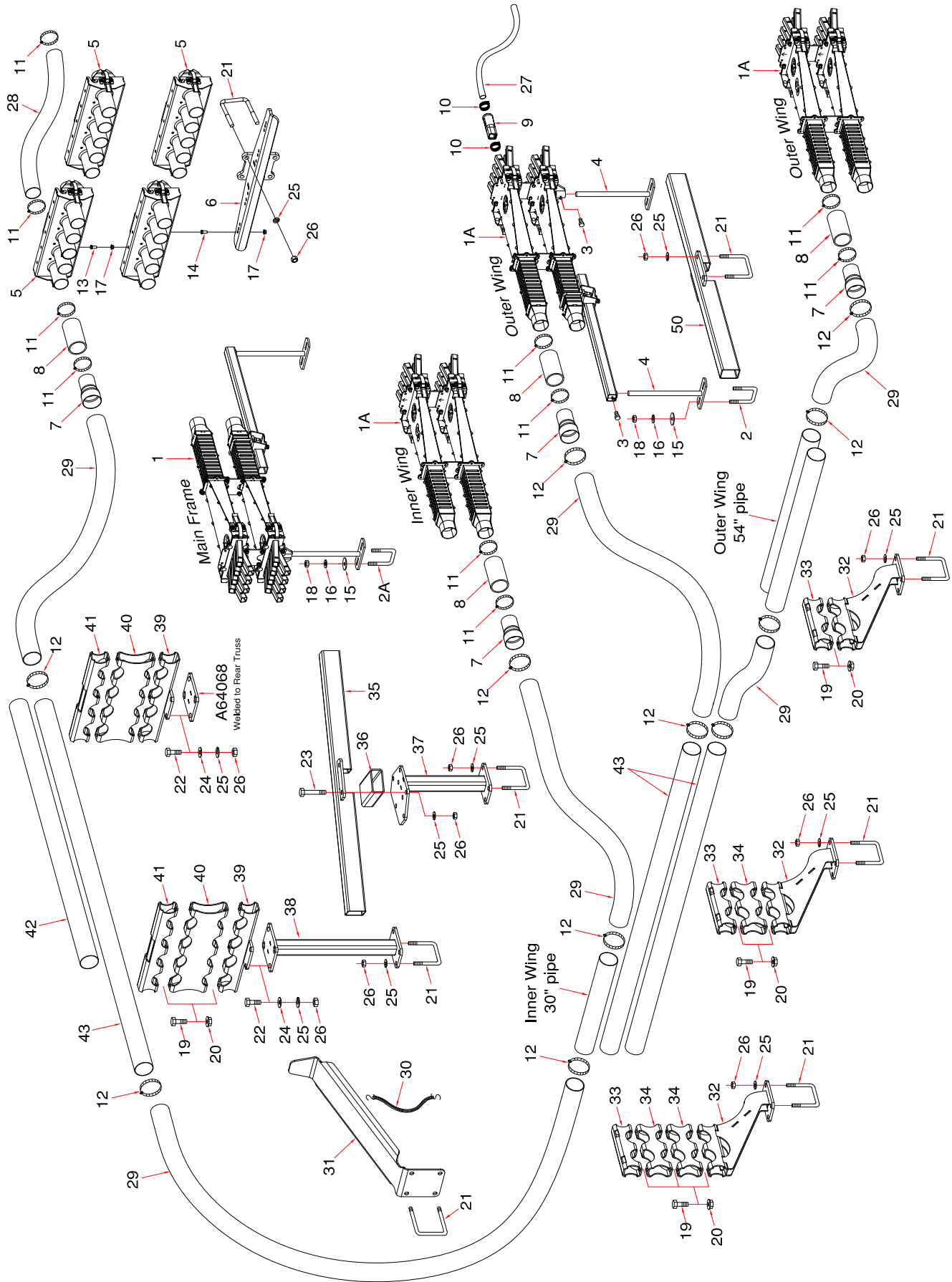

Distribution - Dual Shoot Tow Behind - 80 ft - 2021

Item	Part No.	Description	Qty
1	N69274	Double Shoot Assembly - 8 Outlet (See "Stainless Head Conversion Kits" page 7-36 to 7-40)	1
1A	N68276	Double Shoot Assembly - 9 Outlet (See "Stainless Head Conversion Kits" page 7-36 to 7-40)	8
2	N15097	U-Bolt - 3/8 x 2 x 5	16
2A	N15098	U-Bolt - 3/8 x 4 x 5	2
3	N24396	Setscrew - 1/4 x 1/2	18
4	N19531	Support - Bottom - Rod 24"	18
5	*****	Quick Coupler - 5 Run	2
6	N53203	Coupler Tower - Behind	1
7	N64095	Primary Hose Adapter	36
8	N19428	Hose - 2.54"ID.x 2.79"OD.x 5"	36
9	N65131	Secondary Hose Finger Adapter	160
10	N11470	Hose Clamp - 1 - HC5-20	320
11	N11905	Hose Clamp - 2 1/2 - HC5-44	72
12	N64099	Hose Clamp - 3 - SSTCH5-400	98
13	W-867	Hex Bolt - 3/8 x 3/4 Lg.	4
14	W-187	Hex Bolt - 3/8 x 1 1/4 Lg.	4
15	D-5579	Flatwasher - 3/8	36
16	W-523	Lockwasher - 3/8	36
17	D-5279	Locknut - 3/8 Serrated	8
18	W-514	Hex Nut - 3/8	36
19	W-485	Hex Bolt - 1/2 x 1 1/4 Lg.	60
20	D14565	Locknut - 1/2 Serrated	60
21	C-219	U-Bolt- 5/8 Dia x 4 x 5.563 UL	44
22	W-498	Hex Bolt - 5/8 x 1 3/4 Lg.	16
23	W-503	Hex Bolt - 5/8 x 3 1/2 Lg.	8
24	W-629	Washer - .656 ID x 1.312 OD - 13Ga.	16
25	W-526	Lockwasher - 5/8	112
26	W-517	Nut - 5/8	112
27	R480034	Hose - .929 ID x 1.169 OD/ft (75 ft roll)	1650
28	R480055	Hose - 2 1/2 ID/ft Goodyear (100 ft rolls)	450
29	R480060	Hose - 3 ID/ft (100 ft rolls)	314
30	N64399	Tarp Strap - 31"	2
31	N64081	Primary Hose Support	2
32	N64060	Pipe Clamp Bracket	12
33	N64061	Pipe Clamp - Wing	12
34	N64056	Pipe Clamp Spacer - Wing	10
35	N64071	Head Stand Support	6
36	N64074	Spacer Tube - 2 x 4 x 6 1/2 Lg.	2
37	N64075	Divider Head Stand - Main	2
38	N64070	Pipe Stand - Main	2
39	N64065	Pipe Clamp Bracket - Main	4
40	N64062	Pipe Clamp Spacer - Main	4
41	N64064	Pipe Clamp - Main	4
42	N64092	Primary Pipe SS - 3 x 72 Lg.	4
43	N64094	Primary Pipe SS - 3 x 96 Lg.	20
44	N64096	Primary Pipe SS - 3 x 120 Lg - (Cut to Length for 30" and 54" pipes on wings)	3



Distribution - 9 Series Air Cart Dual Shot Tow Behind - 90 ft - 2018

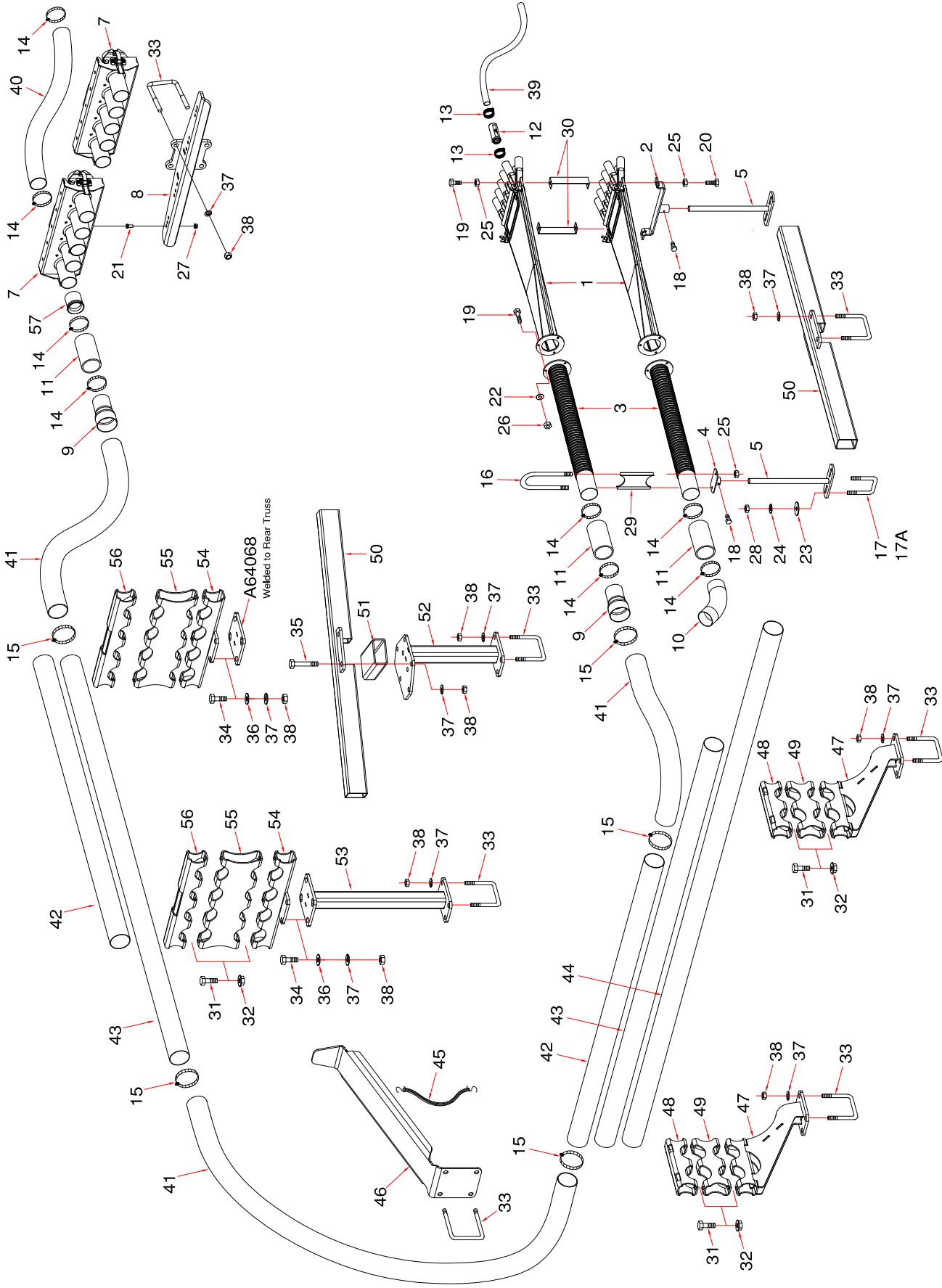

Distribution - Dual Shoot Tow Behind - 90 ft - 2018

Item	Part No.	Description	Qty
1	N42257	Divider Assembly - 10 Outlet.....	18
2	N42244	Support - 10 Outlet - 1 1/8 ID.....	9
3	N15135	Pipe - Corr Diff - Divider Head.....	18
4	N40995	Support - Rear.....	9
5	N19531	Support - Bottom - Rod 24".....	18
7	*****	Quick Coupler - 5 Run.....	2
8	N53203	Coupler Tower - Behind.....	1
9	N64095	Primary Hose Adapter.....	36
10	N64082	Primary Elbow - 45 Degree.....	2
11	N19428	Hose - 2.54"ID.x 2.79"OD.x 5".....	36
12	N62351	Adaptor - Secondary Hose.....	180
13	N11470	Hose Clamp - 1 - HC5-20.....	360
14	N11905	Hose Clamp - 2 1/2 - HC5-44.....	72
15	N64099	Hose Clamp - 3 - SSTCH5-400.....	98
16	N16504	U-Bolt - 1/4 x 2.5 x 9 1/2 Lg.....	9
17	N15097	U-Bolt - 3/8 x 2 x 5.....	16
17A	N15098	U-Bolt - 3/8 x 4 x 5.....	2
18	N24396	Setscrew - 1/4 x 1/2.....	18
19	W-469	Hex Bolt - 1/4 x 3/4 Lg.....	90
20	W-469	Hex Bolt - 1/4 x 1 Lg.....	18
21	W-187	Hex Bolt - 3/8 x 1 1/4 Lg.....	4
22	W-521	Lockwasher - 1/4.....	54
23	D-5579	Flatwasher - 3/8.....	36
24	W-523	Lockwasher - 3/8.....	36
25	D-5277	Serrated Locknut - 1/4.....	54
26	W-512	Hex Nut - 1/4.....	54
27	D-5279	Locknut - 3/8 Serrated.....	4
28	W-514	Hex Nut - 3/8.....	36
29	N16507	Spacer - Rear - Dual Shoot Heads.....	9
30	N16689	Bracket Front - Dual Shoot Heads.....	18
31	W-485	Hex Bolt - 1/2 x 1 1/4 Lg.....	60
32	D14565	Locknut - 1/2 Serrated.....	60
33	C-219	U-Bolt- 5/8 Dia x 4 x 5.563 UL.....	44
34	W-498	Hex Bolt - 5/8 x 1 3/4 Lg.....	16
35	W-503	Hex Bolt - 5/8 x 3 1/2 Lg.....	8
36	W-629	Washer - .656 ID x 1.312 OD-13Ga.....	16
37	W-526	Lockwasher - 5/8.....	112
38	W-517	Nut - 5/8.....	112
39	R480034	Hose - .929 ID x 1.169 OD/ft (75 ft roll).....	1800
40	R480055	Hose - 2 1/2 ID/ft Goodyear (100 ft rolls).....	450
41	R480060	Hose - 3 ID/ft (100 ft rolls).....	362
42	N64092	Primary Pipe SS - 3 x 72 Lg.....	8
43	N64094	Primary Pipe SS - 3 x 96 Lg.....	16
44	N64096	Primary Pipe SS - 3 x 120 Lg.....	8
45	N64399	Tarp Strap - 31".....	2
46	N64081	Primary Hose Support.....	2
47	N64060	Pipe Clamp Bracket.....	12
48	N64061	Pipe Clamp - Wing.....	12
49	N64056	Pipe Clamp Spacer - Wing.....	10
50	N64071	Head Stand Support.....	6
51	N64074	Spacer Tube - 2 x 4 x 6 1/2 Lg.....	2
52	N64075	Divider Head Stand - Main.....	2
53	N64070	Pipe Stand - Main.....	2
54	N64065	Pipe Clamp Bracket - Main.....	4
55	N64062	Pipe Clamp Spacer - Main.....	4
56	N64064	Pipe Clamp - Main.....	4
57	N37920	Equalizer.....	6

Distribution - Dual Shoot Tow Behind - 90 ft - 2018

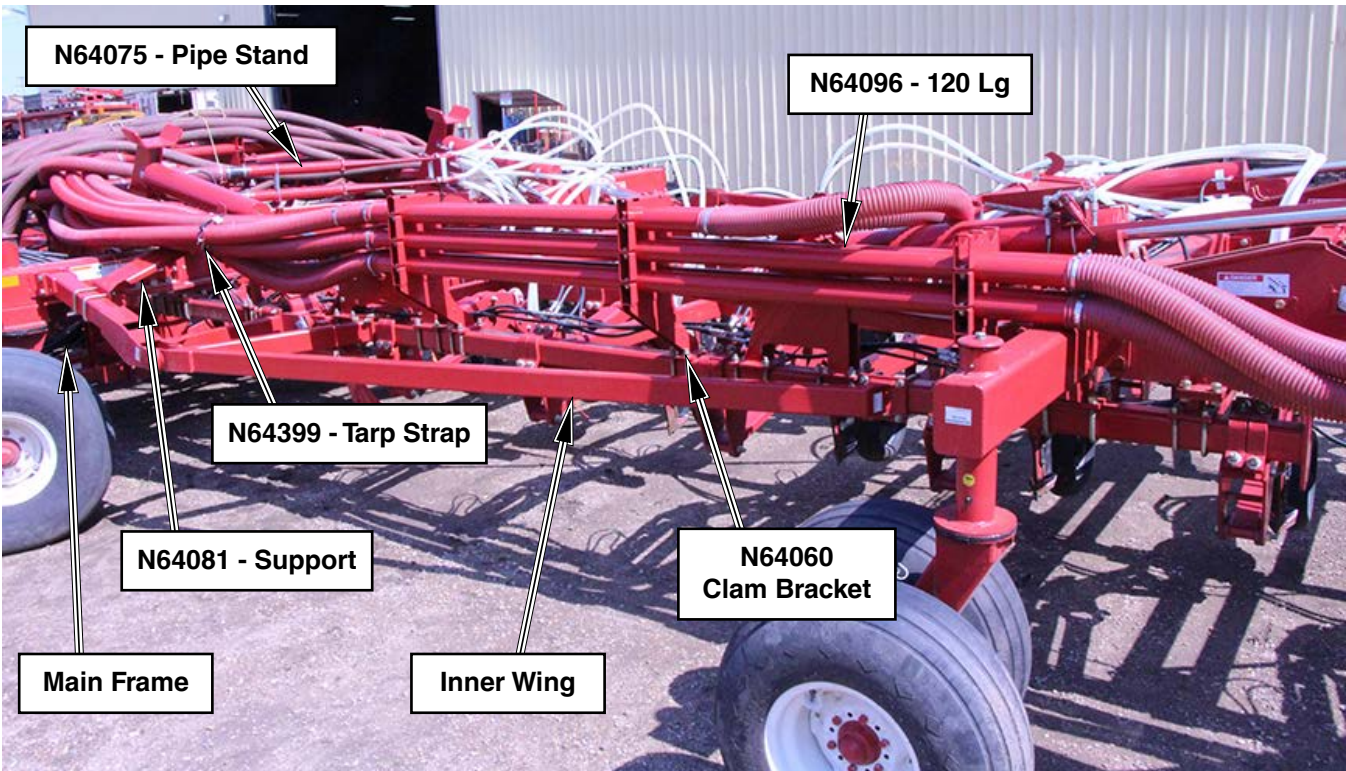
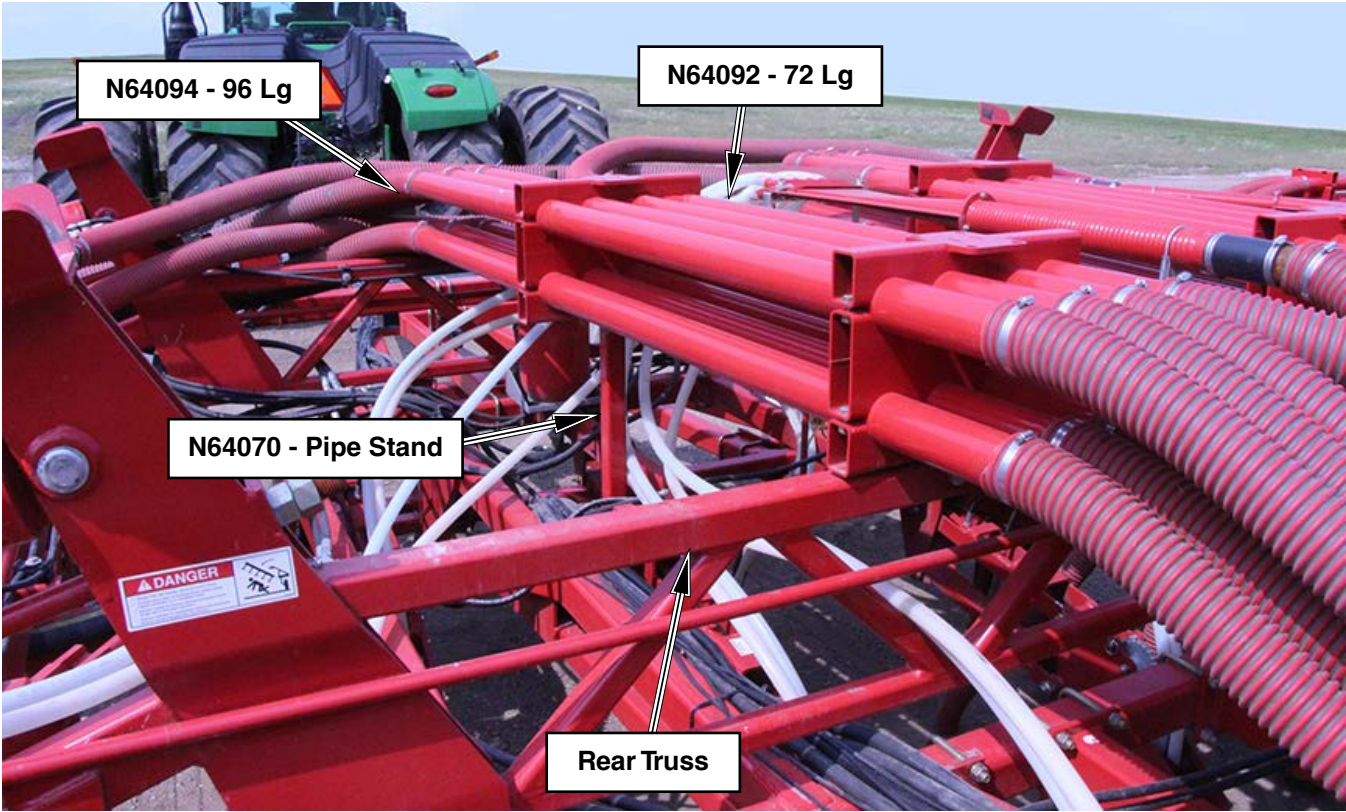

Distribution - Dual Shoot Tow Behind - 90 ft - 2018

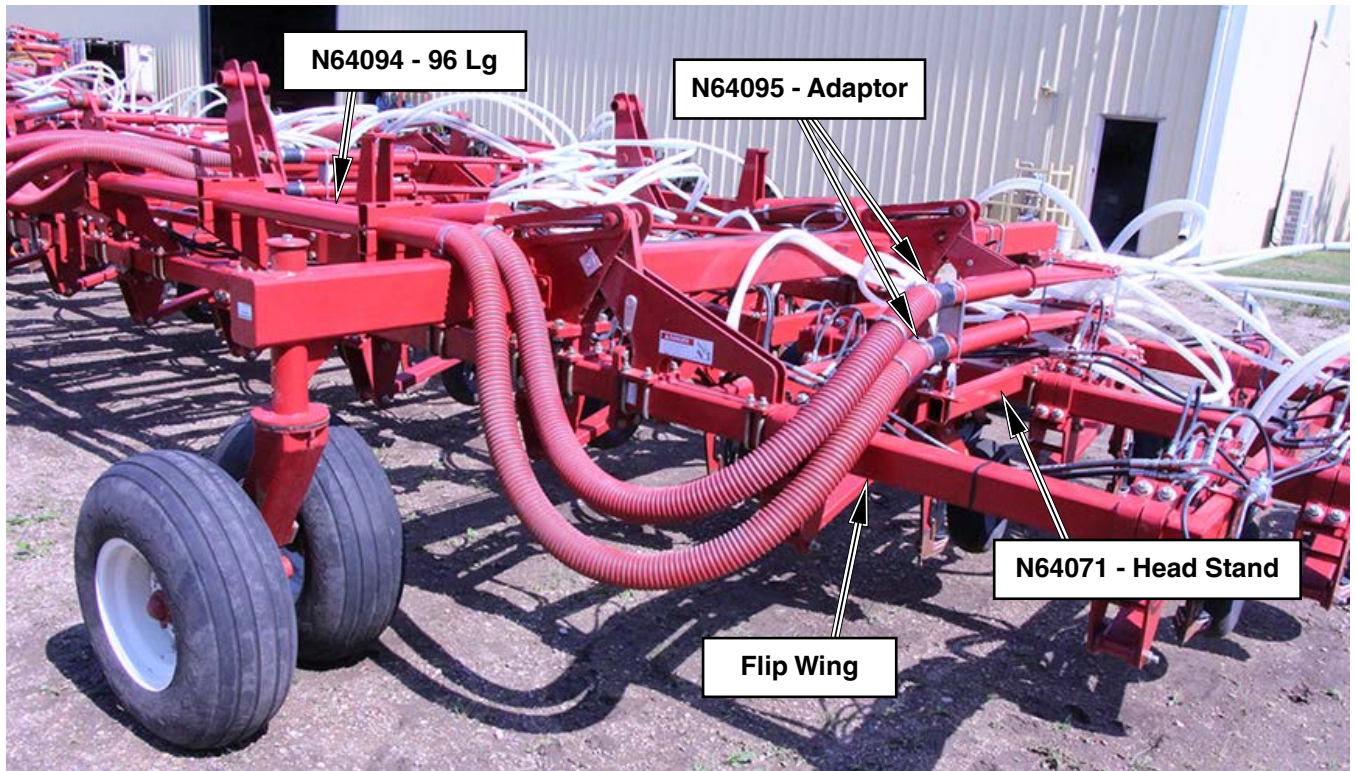
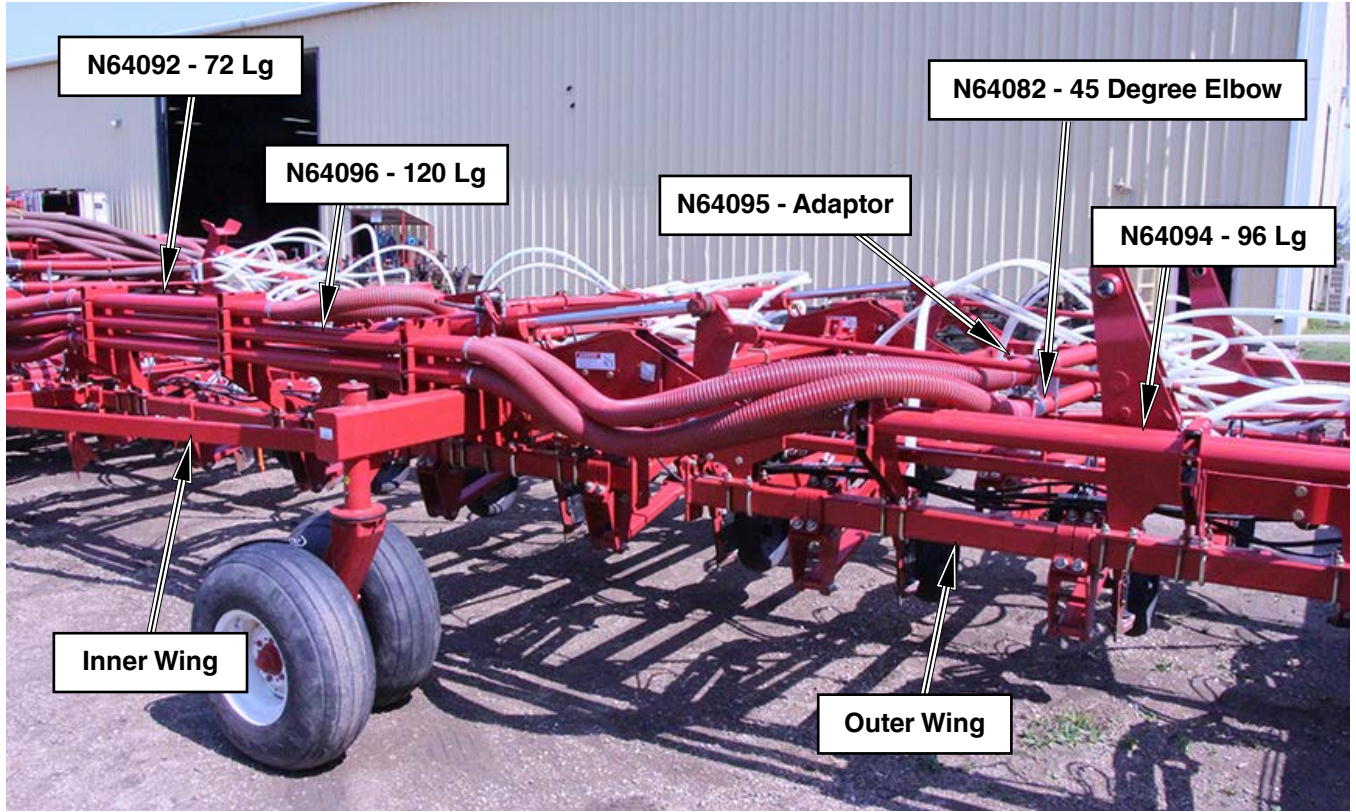

Distribution - 9 Series Air Cart Dual Shoot Tow Between - 25 Ft and 31 Ft

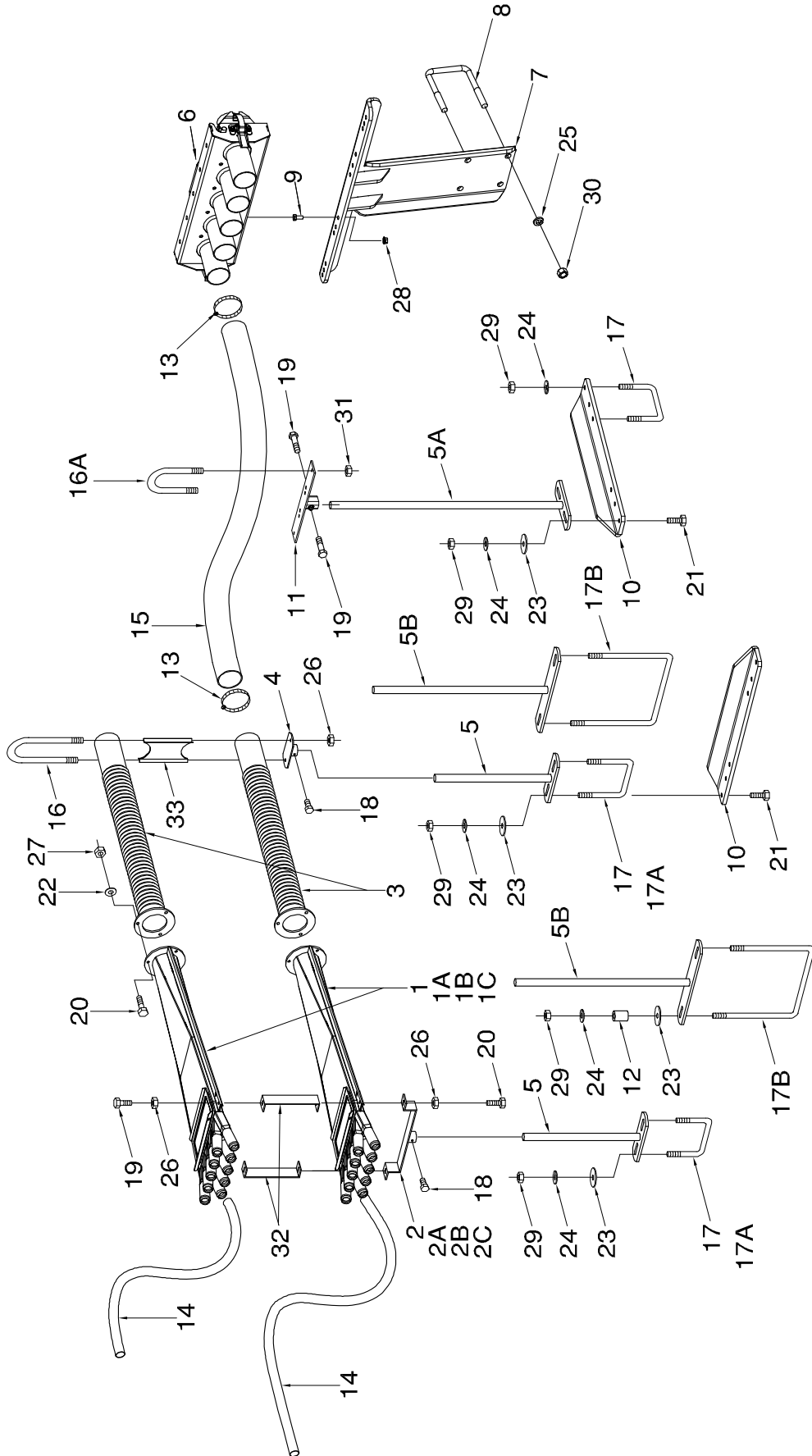

Distribution - Dual Shoot Tow Between - 25 Ft and 31 Ft

Item	Part No.	Description	No: Used			
			25 ft		31 ft	
			10	12	10	12
1	N42274	Divider Assembly - 11 Outlet	-	-	-	-
1A	N31190	Divider Assembly - 10 Outlet.....	-	-	-	-
1B	N31189	Divider Assembly - 9 Outlet.....	-	2	-	-
1C	N31188	Divider Assembly - 8 Outlet.....	4	4	2	6
1D	N31187	Divider Assembly - 7 Outlet.....	4	-	8	2
2	N40544	Support - 11 Outlet.....	-	-	-	-
2A	N19406	Support - 10 Outlet.....	-	-	-	-
2B	N15595	Support - 9 Outlet.....	-	1	-	-
2C	N15107	Support - 8 Outlet.....	3	2	1	3
2D	N15594	Support - 7 Outlet.....	1	-	4	1
3	N15135	Pipe - Corr Diff - Divider Head	8	6	10	8
4	N15102	Support - Rear	4	3	5	4
5	N15105	Support - Bottom - Rod 12".....	8	6	8	8
5A	N19531	Support - Bottom - Rod 24".....	2	2	2	2
5B	N45694	Support - Wide - Bottom - Rod 14".....	-	2	2	-
6	*****	Quick Coupler - 5 Run	2	2	2	2
7	N51962	Coupler Tower - Between - Short.....	1	1	1	1
8	C-219	U-Bolt - 5/8 x 4 x 5 9/16 Lg	2	2	2	2
9	W-867	Hex Bolt - 3/8 x 3/4 Lg.....	4	4	4	4
10	S44308	Extension Bracket - Head Support.....	4	2	2	4
11	N40704	Support - Hose.....	2	2	2	2
12	N11750	Bushing - 0.385 ID x 0.625 OD x 1 1/16 Lg	-	4	4	-
13	N11905	Hose Clamp - 2 1/2.....	32	24	40	32
14	R480034	Hose - .929 ID x 1.169 OD/ft (75 ft roll)	675	600	825	675
15	R480055	Hose - 2 1/2 ID/ft (100 ft rolls)	150	100	200	150
16	N16504	U-Bolt - 1/4 x 2 9/16 x 9 1/2 Lg	8	3	9	8
16A	N37630	U-Bolt - 1/4 x 2 3/4 x 3 3/4 Lg	2	2	2	2
17	N15098	U-Bolt - 3/8 x 4 x 5	6	4	6	6
17A	N15097	U-Bolt - 3/8 x 2 x 5	4	2	4	4
17B	N40715	U-Bolt - 3/8 x 8 x 9 3/4	-	2	2	-
18	N24396	Setscrew - 1/4 x 1/2	8	6	12	8
19	K-3830	Hex Bolt - 1/4 x 1/2 Lg	12	10	14	12
20	W-469	Hex Bolt - 1/4 x 3/4 Lg	32	24	40	32
21	W-187	Hex Bolt - 3/8 x 1 1/4 Lg	8	4	4	8
22	W-521	Lockwasher - 1/4	24	18	30	24
23	D-5579	Flatwasher - 3/8	20	16	24	20
24	W-523	Lockwasher - 3/8.....	28	16	28	28
25	W-526	Lockwasher - 5/8.....	4	4	4	4
26	D-5277	Serrated Locknut - 1/4.....	24	18	30	24
27	W-512	Hex Nut - 1/4.....	24	18	30	24
28	D-5279	Serrated Locknut - 3/8.....	12	12	12	12
29	W-514	Hex Nut - 3/8.....	28	20	28	28
30	W-517	Hex Nut - 5/8.....	4	4	4	4
31	N22778	Locknut Nylon Insert - 1/4	8	4	8	8
32	N16689	Bracket Front - Dual Shoot Heads.....	8	6	10	8
33	N16507	Spacer - Rear - Dual Shoot Heads	4	3	5	4

**Distribution - 9 Series Air Cart
Dual Shot Tow Between - 41 to 51 ft**

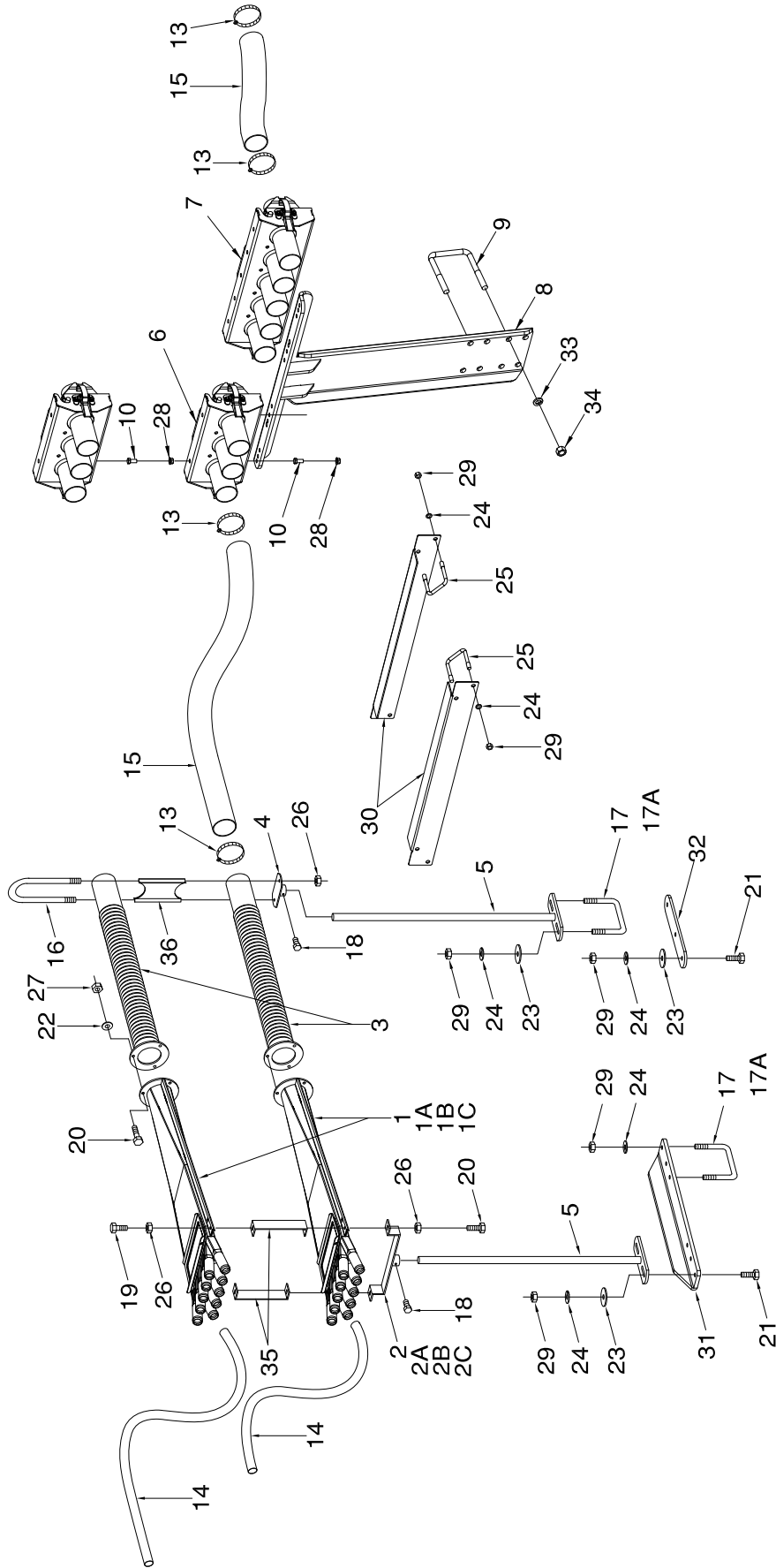

Distribution - Dual Shoot Tow Between - 41 to 51 ft

Item	Part No.	Description	No: Used			
			41 ft		51 ft	
			10	12	10	12
1	N42274	Divider Assembly - 11 Outlet	-	-	-	-
1A	N31190	Divider Assembly - 10 Outlet.....	-	-	-	-
1B	N31189	Divider Assembly - 9 Outlet.....	4	2	8	-
1C	N31188	Divider Assembly - 8 Outlet.....	8	8	6	4
1D	N31187	Divider Assembly - 7 Outlet.....	-	-	-	10
2	N40544	Support - 11 Outlet.....	-	-	-	-
2A	N19406	Support - 10 Outlet.....	4	-	-	-
2B	N15595	Support - 9 Outlet.....	8	2	8	-
2C	N15107	Support - 8 Outlet.....	-	8	6	4
2D	N15594	Support - 7 Outlet.....	-	-	-	10
3	N15135	Pipe - Corr Diff - Divider Head	12	10	16	14
4	N15102	Support - Rear	6	5	8	7
5	N19531	Support - Bottom - Rod 24".....	14	12	18	16
6	*****	Quick Coupler - 3 Run	2	2	0	0
7	*****	Quick Coupler - 5 Run	0	0	2	2
8	N51967	Coupler Tower - Between - Tall	1	1	1	1
9	C-219	U-Bolt - 5/8 x 4 x 5 9/16 Lg	2	2	2	2
10	W-867	Hex Bolt - 3/8 x 3/4 Lg.....	8	8	8	8
11	W-526	Lockwasher - 5/8.....	4	4	4	4
12	W-517	Hex Nut - 5/8.....	4	4	4	4
13	N11905	Hose Clamp - 2 1/2	24	20	32	28
14	R480034	Hose - .929 ID x 1.169 OD/ft (75 ft roll)	900	900	1200	1050
15	R480055	Hose - 2 1/2 ID/ft (100 ft rolls)	250	200	200	200
16	N16504	U-Bolt - 1/4 x 2 9/16 x 9 1/2 Lg	6	5	8	7
17	N15098	U-Bolt - 3/8 x 4 x 5	18	16	22	20
17A	N15097	U-Bolt - 3/8 x 2 x 5	14	12	18	16
18	N24396	Setscrew - 1/4 x 1/2	14	12	18	16
19	K-3830	Hex Bolt - 1/4 x 1/2 Lg	12	10	16	14
20	W-469	Hex Bolt - 1/4 x 3/4 Lg	38	32	50	44
21	W-187	Hex Bolt - 3/8 x 1 1/4 Lg	0	4	6	4
22	W-521	Lockwasher - 1/4	36	30	48	42
23	D-5579	Flatwasher - 3/8	28	24	36	32
24	W-523	Lockwasher - 3/8.....	52	52	66	60
25	D12714	U-Bolt - 3/8.....	8	8	8	8
26	D-5277	Serrated Locknut - 1/4.....	26	22	34	30
27	W-512	Hex Nut - 1/4.....	36	30	48	42
28	D-5279	Serrated Locknut - 3/8.....	12	12	12	12
29	W-514	Hex Nut - 3/8.....	52	52	66	60
30	S44307	Support Bracket - Distribution	4	4	4	4
31	S44308	Extension Bracket - Head Support.....	0	2	2	4
32	S44467	Head Support Plate	0	0	0	0
35	N16689	Bracket Front - Dual Shoot Heads.....	12	10	16	14
36	N16507	Spacer - Rear - Dual Shoot Heads	6	5	8	7

Distribution - 9 Series Air Cart Dual Shot Tow Between - 61 to 90 ft

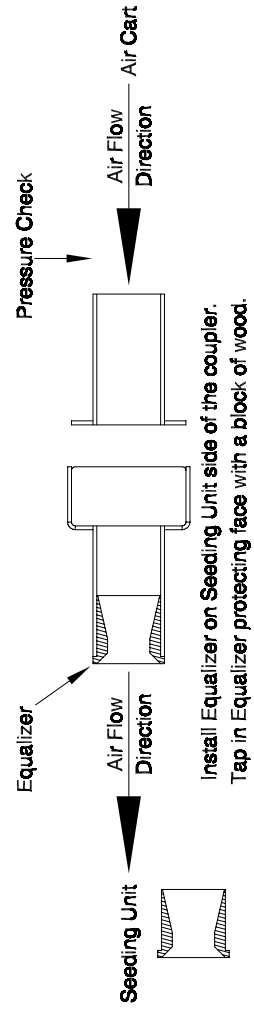
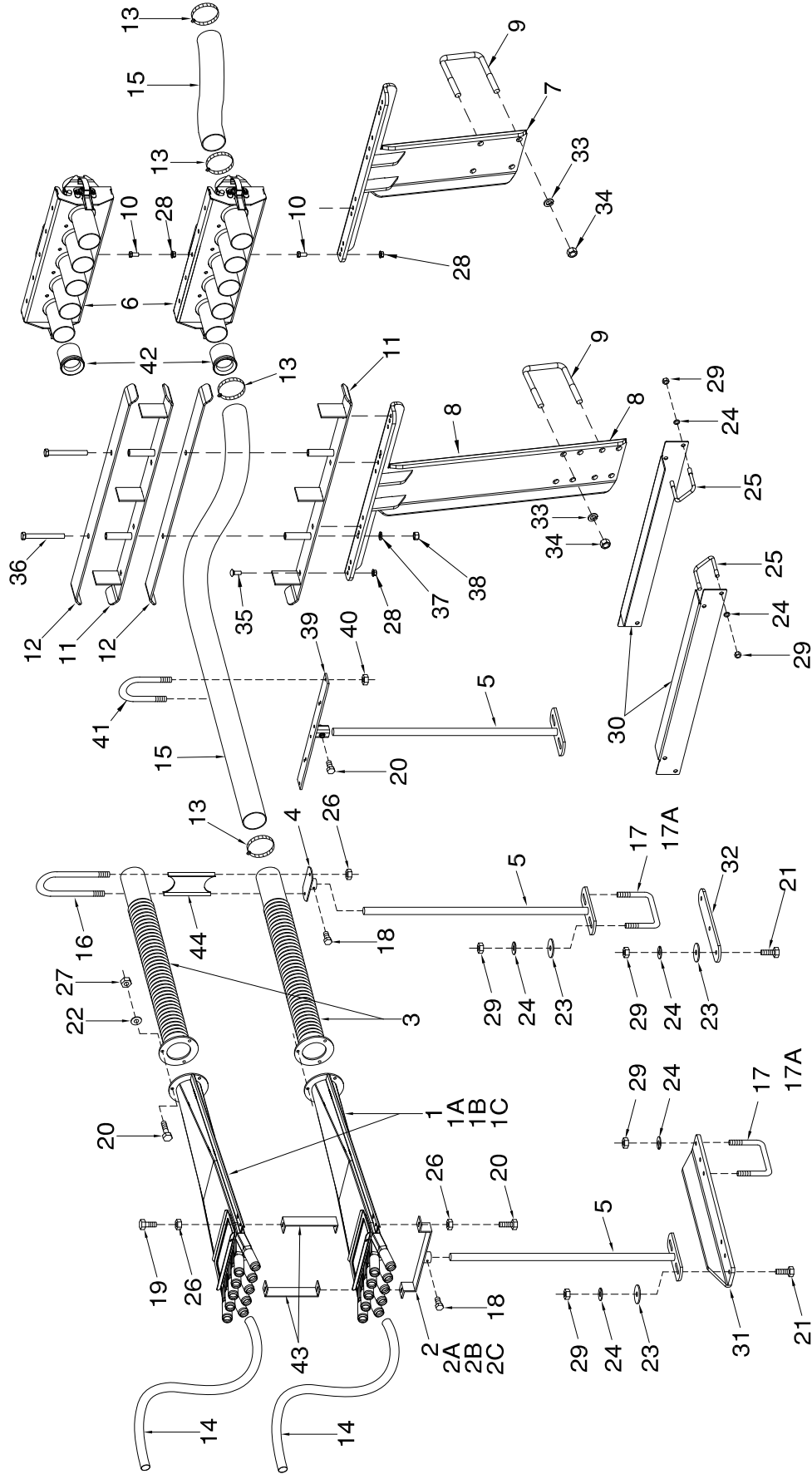

Install Equalizer on Seeding Unit side of the coupler.
Tap in Equalizer protecting face with a block of wood.

Distribution - Dual Shoot Tow Between - 61 to 90ft

Item	Part No.	Description	No. Used						
			61 ft		71 ft		80ft	86ft	90ft
			10	12	10	12	12	12	12
1	N42274	Divider Assembly - 11 Outlet	-	-	-	-	-	-	-
1A	N31190	Divider Assembly - 10 Outlet	-	-	6	-	-	10	18
1B	N31189	Divider Assembly - 9 Outlet	-	-	12	-	16	8	-
1C	N31188	Divider Assembly - 8 Outlet	18	10	-	16	2	-	-
1D	N31187	Divider Assembly - 7 Outlet	-	6	-	2	-	-	-
2	N40544	Support - 11 Outlet	-	-	-	-	-	-	-
2A	N19406	Support - 10 Outlet	-	-	6	-	-	10	18
2B	N15595	Support - 9 Outlet	-	-	12	-	16	8	-
2C	N15107	Support - 8 Outlet	18	10	-	16	2	-	-
2D	N15594	Support - 7 Outlet	-	6	-	2	-	-	-
3	N15135	Pipe - Corr Diff - Divider Head.....	16	14	18	18	18	18	18
4	N15102	Support - Rear	9	8	9	9	9	9	9
5	N19531	Support - Bottom - Rod 24"	20	18	20	20	20	20	20
6	*****	Quick Coupler - 5 Run	2	2	2	2	2	2	2
7	N51962	Coupler Tower - Between - Short	1	1	1	1	1	1	1
8	N51967	Coupler Tower - Between - Tall	1	1	1	1	1	1	1
9	C-219	U-Bolt - 5/8 x 4 x 5 9/16 Lg.....	2	2	2	2	2	2	2
10	W-867	Hex Bolt - 3/8 x 3/4 Lg.....	4	4	4	4	4	4	4
11	N51979	Hose Clamp Strap	1	1	1	1	1	1	1
12	N51977	Clamp Plate	1	1	1	1	1	1	1
13	N11905	Hose Clamp - 2 1/2	36	28	36	36	36	36	36
14	R480034	Hose - .929 ID x 1.169 OD/ft (75 ft roll)	1200	1050	1650	1500	1650	1650	1800
15	R480055	Hose - 2 1/2 ID/ft (100 ft rolls).....	500	450	600	600	650	650	650
16	N16504	U-Bolt - 1/4 x 2 9/16 x 9 1/2 Lg.....	9	8	9	9	9	9	9
17	N15098	U-Bolt - 3/8 x 4 x 5.....	24	22	24	24	24	24	24
17A	N15097	U-Bolt - 3/8 x 2 x 5.....	20	18	20	20	20	20	20
18	N24396	Setscrew - 1/4 x 1/2.....	20	18	20	20	20	20	20
19	K-3830	Hex Bolt - 1/4 x 1/2 Lg.....	18	16	18	18	18	18	18
20	W-469	Hex Bolt - 1/4 x 3/4 Lg.....	54	48	54	54	54	54	54
21	W-187	Hex Bolt - 3/8 x 1 1/4 Lg.....	15	6	15	15	15	15	15
22	W-521	Lockwasher - 1/4	54	48	54	54	54	54	54
23	D-5579	Flatwasher - 3/8.....	40	36	40	40	40	40	40
24	W-523	Lockwasher - 3/8	79	66	79	79	79	79	79
25	D12714	U-Bolt - 3/8	8	8	8	8	8	8	8
26	D-5277	Serrated Locknut - 1/4	54	48	54	54	54	54	54
27	W-512	Hex Nut - 1/4	54	48	54	54	54	54	54
28	D-5279	Serrated Locknut - 3/8	12	12	12	12	12	12	12
29	W-514	Hex Nut - 3/8	79	66	79	79	79	79	79
30	S44307	Support Bracket - Distribution.....	4	4	4	4	4	4	4
31	S44308	Extension Bracket - Head Support	2	4	7	7	7	7	7
32	S44467	Head Support Plate	2	2	1	1	1	1	1
33	W-526	Lockwasher - 5/8	4	4	4	4	4	4	4
34	W-517	Hex Nut - 5/8	4	4	4	4	4	4	4
35	P7C616	Carriage Bolt - 3/8 x 1 Lg.....	4	4	4	4	4	4	4
36	W-3687	Hex Bolt - 1/2 x 8 Lg.....	2	2	2	2	2	2	2
37	W-525	Lockwasher - 1/2	2	2	2	2	2	2	2
38	W-516	Hex Nut - 1/2	2	2	2	2	2	2	2
39	N48297	Hose Support - 80 to 90	0	0	0	0	2	2	2
40	N22778	Locknut - 1/4 nylon insert	0	0	0	0	16	16	16
41	N37630	U-Bolt - 1/4 x 2 3/4 x 3 3/4.....	0	0	0	0	8	8	8
42	N37920	Equalizer.....	14	10	6	6	10	10	10
43	N16689	Bracket Front - Dual Shoot Heads	18	16	18	18	18	18	18
44	N16507	Spacer - Rear - Dual Shoot Heads	9	8	9	9	9	9	9

Distribution Broadcast - Mounting Brackets

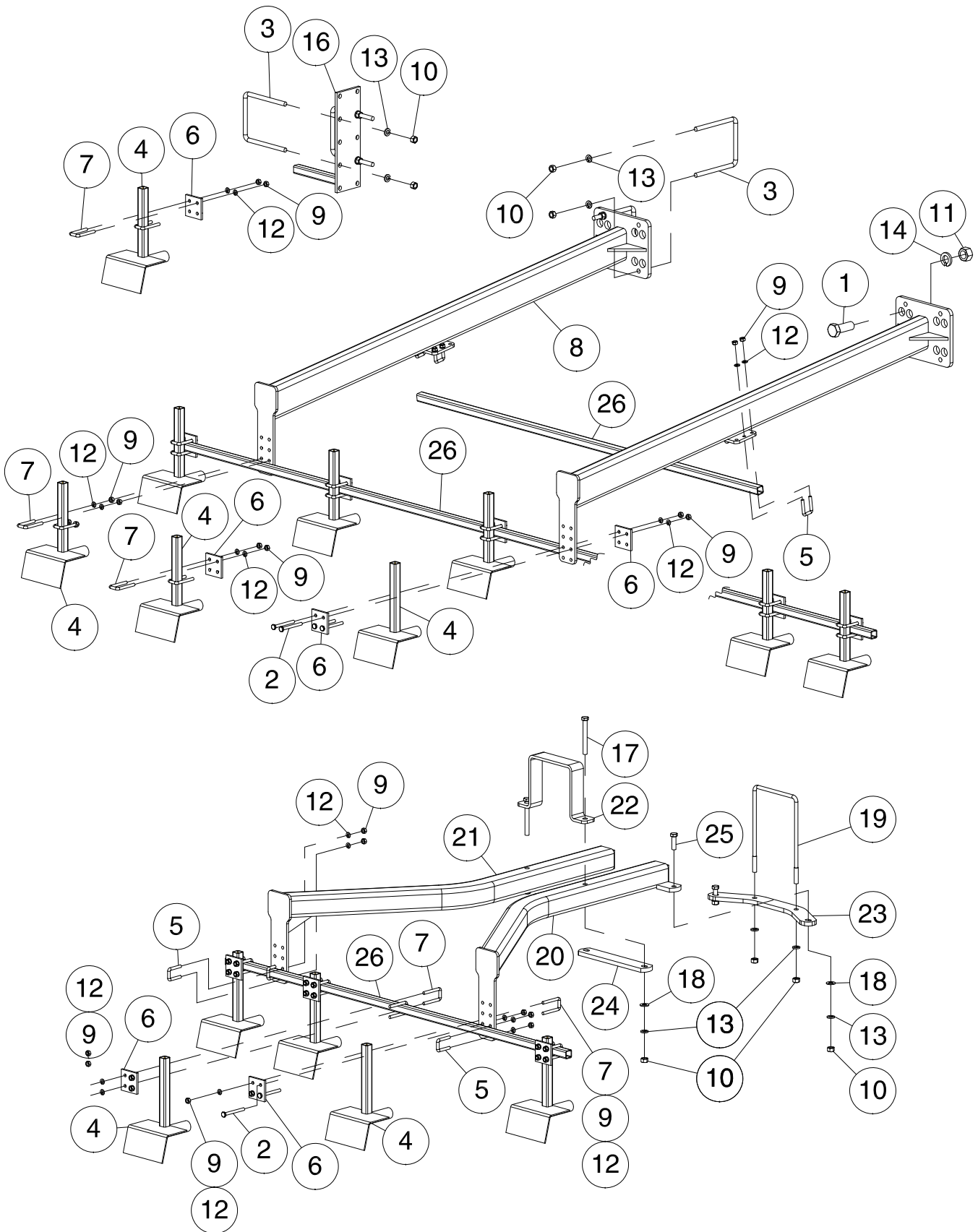

Distribution - Broadcast - Mounting Brackets

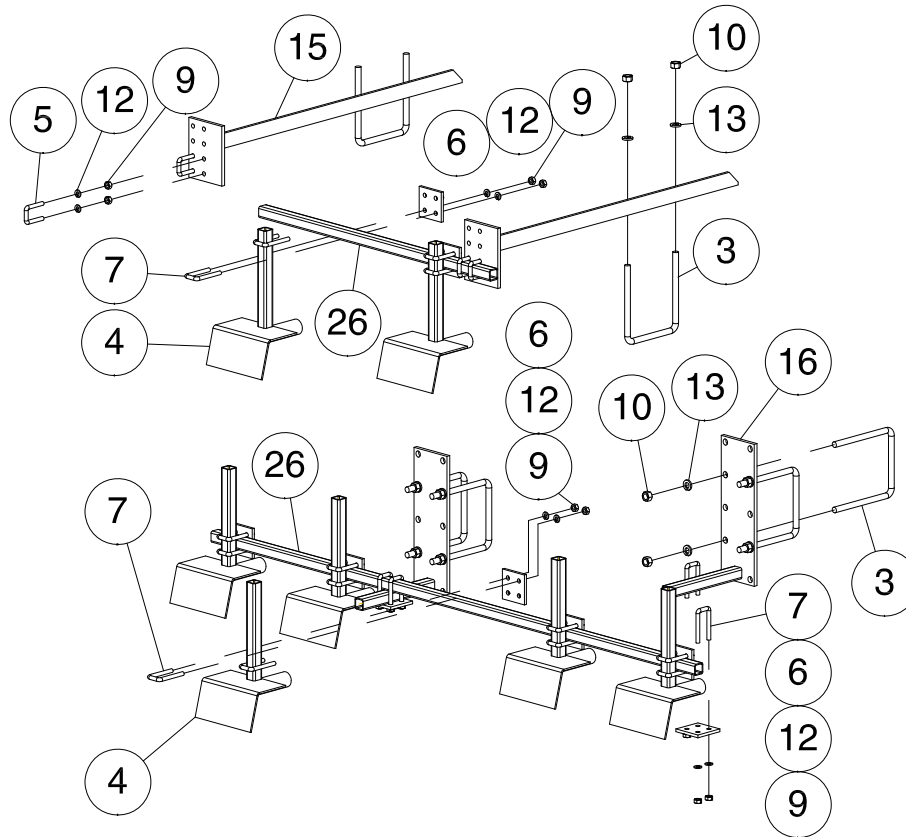

Item	Part No.	Description	Qty
1	C-695	Hex Bolt - 3/4 x 2 Lg.....	2
2	C15319	Hex Bolt - 1/4 x 2 1/2 Lg.....	4
3	N15098	U-Bolt - 3/8 x 4 x 5 UL.....	2
4	N19770	Deflector - 1" Outlet Heads.....	8
	N45690	Deflector - 1 1/4" Outlet Heads	
5	N21055	U-Bolt - 1/4 x 3/4 x 1 3/8 UL.....	4
6	N21060	Clamp Plate	8
7	N21061	U-Bolt - 1/4 x 3/4 x 2	14
8	N60330	Deflector Bracket.....	2
9	W-512	Hex Nut - 1/4	40
10	W-514	Hex Nut - 3/8	4
11	W-518	Hex Nut - 3/4	2
12	W-521	Lockwasher - 1/4.....	40
13	W-523	Lockwasher - 3/8.....	4
14	W-527	Lockwasher - 3/4.....	2
15	N19769	Deflector Bracket.....	1
16	N24308	Deflector Mount "B"	1
17	D-5249	Hex Bolt - 3/8 x 3 1/4 Lg.....	2
18	D-5489	Washer - 13/32 ID x 13/16 OD x 16 Ga.....	4
19	N34025	U-Bolt - 3/8 x 5 x 8 UL.....	1
20	N45036	Mount Bracket.....	1
21	N45037	Mount Bracket.....	1
22	N45042	Mounting Bracket	1
23	N60331	Anchor Strap	1
24	N60332	Anchor Strap	1
25	W-187	Hex Bolt - 3/8 x 1 1/4 Lg.....	2
26	N21080	Mounting Tube	1

Stainless Head Conversion Kits Chart

Morris has introduced Kits to convert older Morris Seeding Units to the new stainless steel divider heads which were introduced on the QUANTUM Air Drill. Below is a chart of the kits available and the components in each kit.

To view pricing and to place an order, please see BPI (Online Ordering System). Kits are made as ordered.

Stainless Steel Divider Head Conversion Kits									
Part No.	Description	Kit Numbers							
		N69271 7OUT-SS	N69272 7OUT-DS	N69273 8OUT-SS	N69274 8OUT-DS	N69275 9OUT-SS	N69276 9OUT-DS	N69277 10OUT-SS	N69278 10OUT-DS
N66507	Stainless Divider Head Assy - 7	1	2	--	--	--	--	--	--
N66508	Stainless Divider Head Assy - 8	--	--	1	2	--	--	--	--
N66509	Stainless Divider Head Assy - 9	--	--	--	--	1	2	--	--
N66510	Stainless Divider Head Assy - 10	--	--	--	--			1	2
N66662	Diffuser - Straight	1	2	1	2	1	2	1	2
N65131	Hose Finger Adapter	7	14	8	16	9	18	10	20
N66140	Dual Head Mounting Plate - LOW	--	2	--	2	--	2	--	2
N69290	Head Conversion Bracket	1	1	1	1	1	1	1	1
N69296	Adapter Insert Tube	1	1	1	1	1	1	1	1
N69295	Extension Tube	1	1	1	1	1	1	1	1
N36148	U-Bolt - 3/8 X 3 X 4	1	1	1	1	1	1	1	1
W-475	Bolt - 3/8 X 1	1	1	1	1	1	1	1	1
W-523	Lock Washer - 3/8	2	2	2	2	2	2	2	2
W-514	Hex Nut - 3/8	2	2	2	2	2	2	2	2
W-469	Hex Bolt - 1/4 X 3/4	4	8	4	8	4	8	4	8
W-1552	Hex Bolt - 1/4 X 1	2	6	2	6	2	6	2	6
D-5277	Serrated Lock Nut - 1/4	6	14	6	14	6	14	6	14
K24396	Set Screw - 1/4	2	2	2	2	2	2	2	2
N11470	Hose Clamp - 1-1/4"	14	28	16	32	18	36	20	40
N11905	Hose Clamp - 2-1/2"	1	2	1	2	1	2	1	2

SS - Single Shoot

DS - Double Shoot

Head Assemblies mount directly to existing Head Stands.

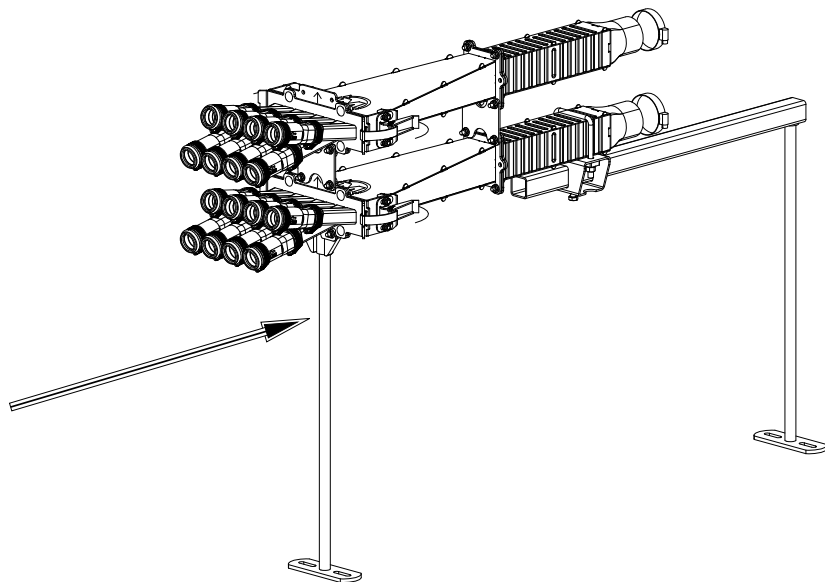

Stainless Head Conversion Kits Divider Head Mounting Stands

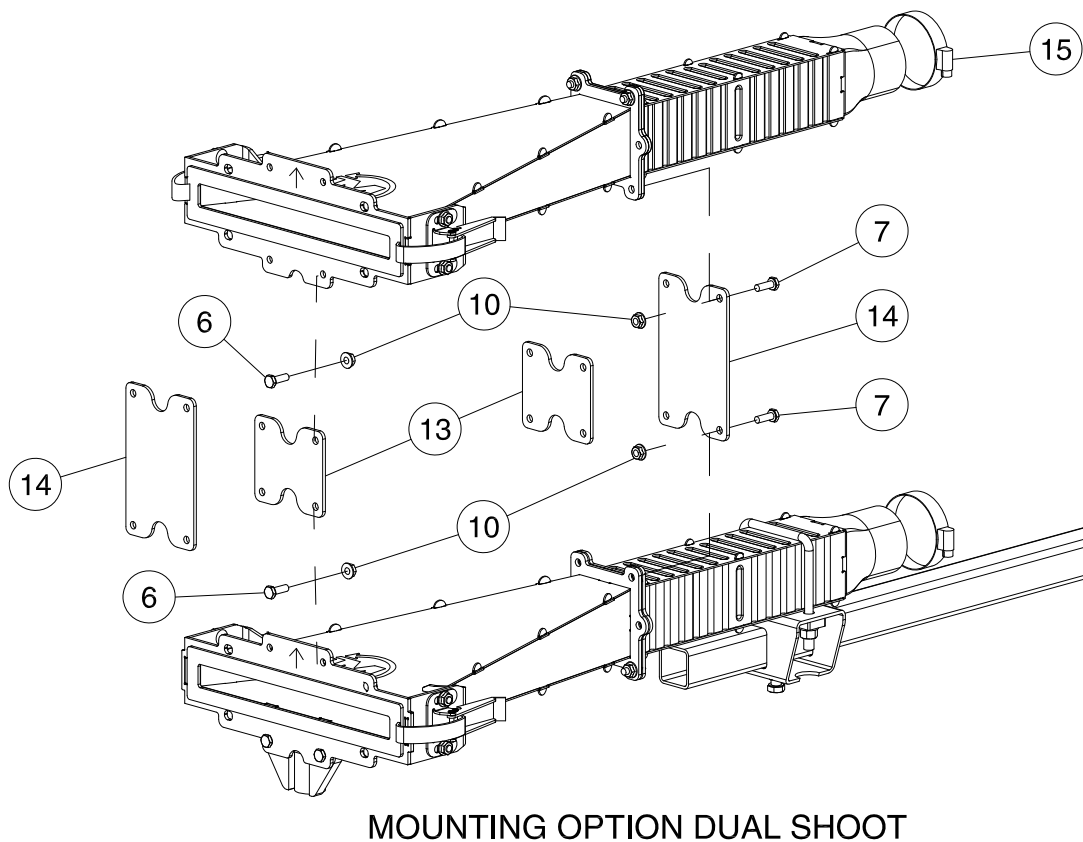
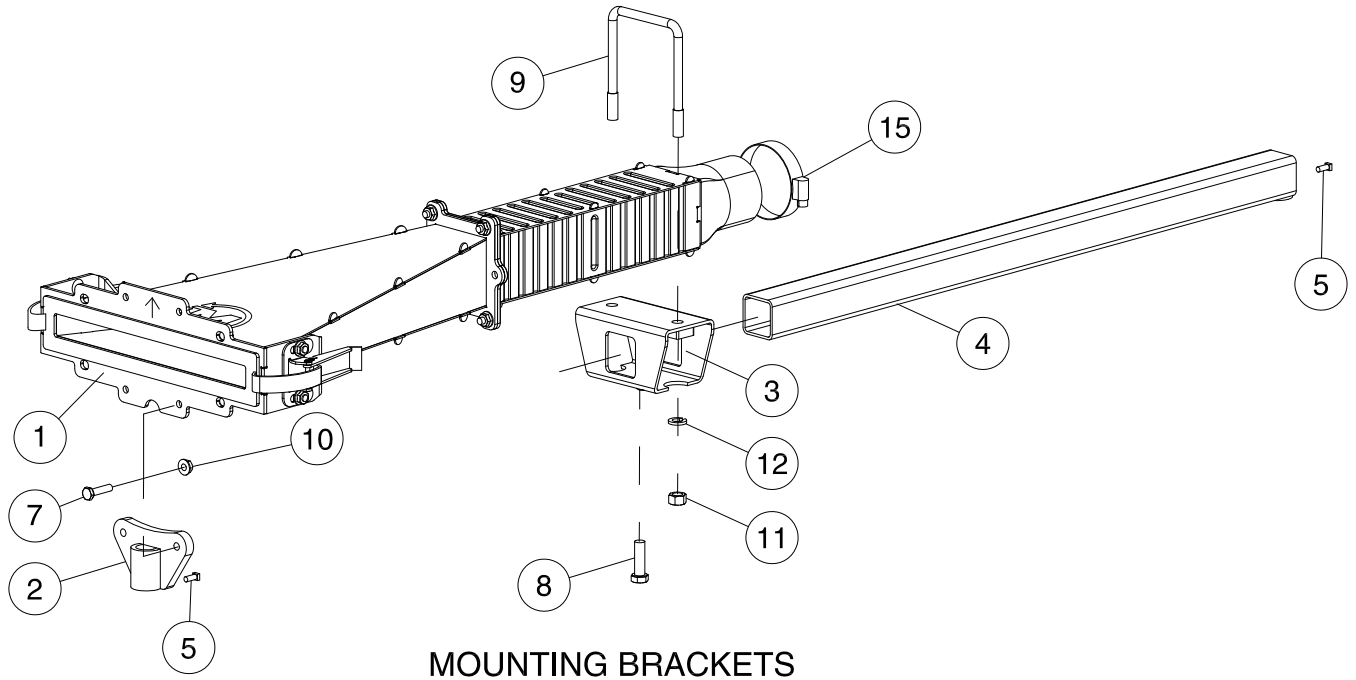

Stainless Head Conversion Kits - Divider Head Mounting Stands

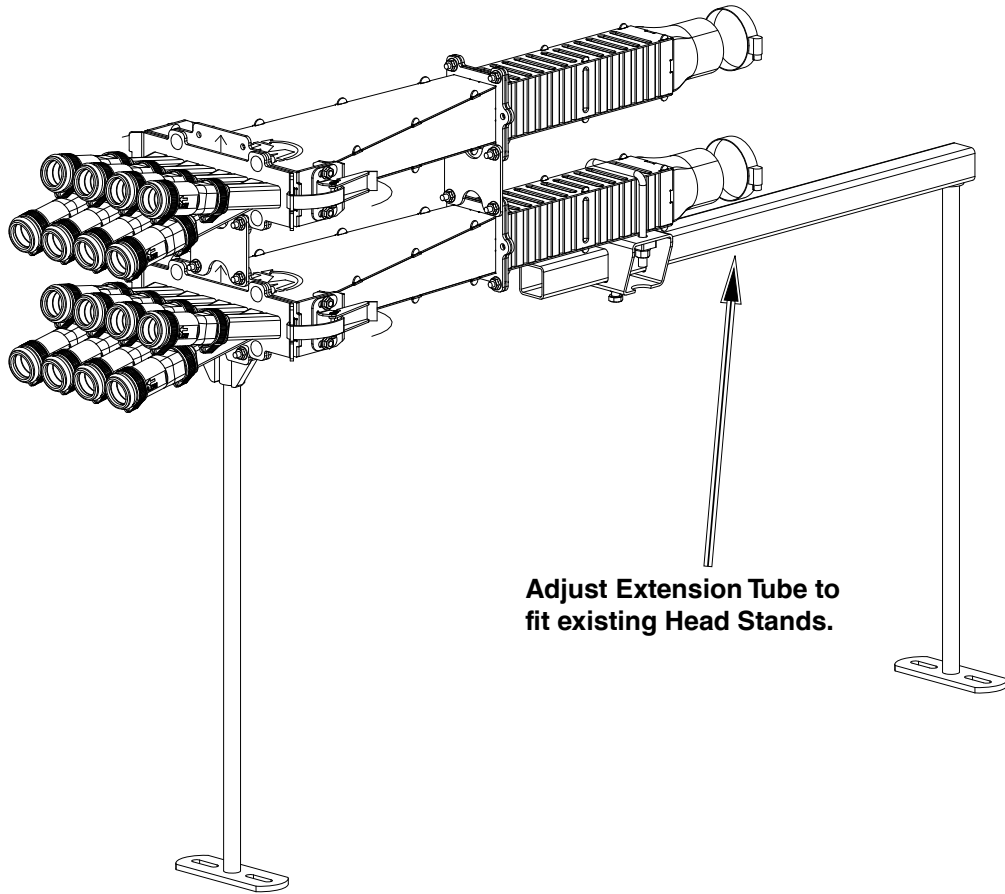

Item	Part No.	Description	Qty
1	*****	Divider Head and Diffuser Tube Assembly - See next page	1
2	N69290	Bracket Head Adapter Stand	1
3	N69296	Adapter Insert Tube	1
4	N69295	Extension Tube	1
5	N24396	Set Screw - 1/4 x 1/2 Lg.....	2
6	W-469	Hex Head - 1/4 x 3/4 Lg	4
7	W-1552	Hex Bolt - 1/4 x 1 Lg.....	2
8	W-475	Hex Bolt - 3/8 x 1 Lg	1
9	N36148	U-Bolt - 3/8 x 3 x 4 UL.....	2
10	D-5277	Lock Nut - 1/4 Serrated Flange	10
11	W-514	Hex Nut - 3/8.....	2
12	W-523	Lockwasher - 3/8.....	2
13	N66140	Dual Head Mounting Plate Low Profile	2
14	N66141	Dual Head Mounting Plate High Profile (Optional)	2
15	N11905	Hose Clamp - 2 1/2 - HC5-44	1

Stainless Head Conversion Kits Divider Head Assembly

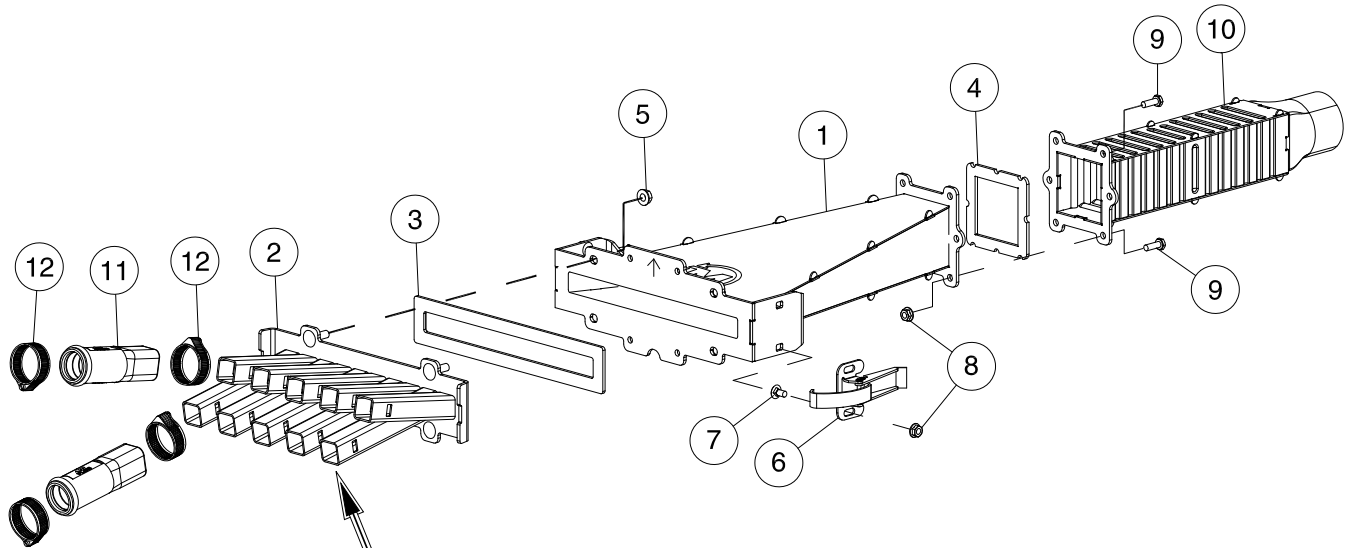

Note: Assemble with long fingers to bottom.

Item	Part No.	Description	Qty
SEVEN OUTLET DIVIDER HEAD			
1	N66557	7 Outlet Divider Head - Main Body	1
2	N66517	7 Outlet Flange	1
3	N66177	Seal - 7 Outlet	1
4	N66175	Diffuser Seal	1
5	D-5278	Flange Lock Nut - 5/16	4
6	N42213	Over-Center Catch	2
7	N53215	Carriage Bolt - 1/4 x 1/2 Lg	4
8	D-5277	Flange Lock Nut - 1/4 Serrated	4
	N66507	Divider Head Assembly - 7 Outlet (Includes All Above Items)	4
11	N65131	Secondary Hose Finger Adapter	7
12	N11470	Hose Clamp - HC5-20 - 20mm Diameter	14
EIGHT OUTLET DIVIDER HEAD			
1	N66558	8 Outlet Divider Head - Main Body	1
2	N66518	8 Outlet Flange - 1 inch Square Fingers	1
3	N66178	Seal - 8 Outlet	1
4	N66175	Diffuser Seal	1
5	D-5278	Flange Lock Nut - 5/16	4
6	N42213	Over-Center Catch	2
7	N53215	Carriage Bolt - 1/4 x 1/2 Lg	4
8	D-5277	Flange Lock Nut - 1/4 Serrated	4
	N66508	Divider Head Assembly - 8 Outlet (Includes All Above Items)	4
11	N65131	Secondary Hose Finger Adapter	8
12	N11470	Hose Clamp - HC5-20 - 20mm Diameter	16

Stainless Head Conversion Kits - Divider Head Assembly

Item	Part No.	Description	Qty
NINE OUTLET DIVIDER HEAD			
1	N66559	9 Outlet Divider Head - Main Body	1
2	N66519	9 Outlet Flange - 1 inch Square Fingers	1
3	N66179	Seal - 9 Outlet	1
4	N66175	Diffuser Seal	1
5	D-5278	Flange Lock Nut - 5/16.....	4
6	N42213	Over-Center Catch	2
7	N53215	Carriage Bolt - 1/4 x 1/2 Lg	4
8	D-5277	Flange Lock Nut - 1/4 Serrated	4
	N66509	Divider Head Assembly - 9 Outlet (Includes All Above Items)	
11	N65131	Secondary Hose Finger Adapter	9
12	N11470	Hose Clamp - HC5-20 - 20mm Diameter	18
TEN OUTLET DIVIDER HEAD			
1	N66560	10 Outlet Divider Head - Main Body.....	1
2	N66520	10 Outlet Flange - 1 inch Square Fingers	1
3	N66180	Seal - 10 Outlet (Not Shown)	1
4	N66175	Diffuser Seal	1
5	D-5278	Flange Lock Nut - 5/16.....	4
6	N42213	Over-Center Catch	2
7	N53215	Carriage Bolt - 1/4 x 1/2 Lg	4
8	D-5277	Flange Lock Nut - 1/4 Serrated	4
	N66510	Divider Head Assembly - 10 Outlet (Includes All Above Items)	
11	N65131	Secondary Hose Finger Adapter	10
12	N11470	Hose Clamp - HC5-20 - 20mm Diameter	20
DIFFUSER PIPE			
8	D-5277	Flange Lock Nut - 1/4 Serrated	4
9	W-469	Hex Head - 1/4 x 3/4 Lg	2
10	N66662	Diffuser - Straight	1

Section 8: Options

Section Contents

Weight Kit.....	8-2
Rear Tow Hitch	8-3
Hitch Truss Kit - 61 and 71 Foot.....	8-4
Wing Lift Brace Kit - 81, 86 & 90 Foot	8-6
Remote Clutch Switch - Prior to September 2012	8-8
Remote Clutch Switch - September 2012 to 2014	8-9
Remote Clutch Switch - September 2014 to Present.....	8-10

Options Weight Kit

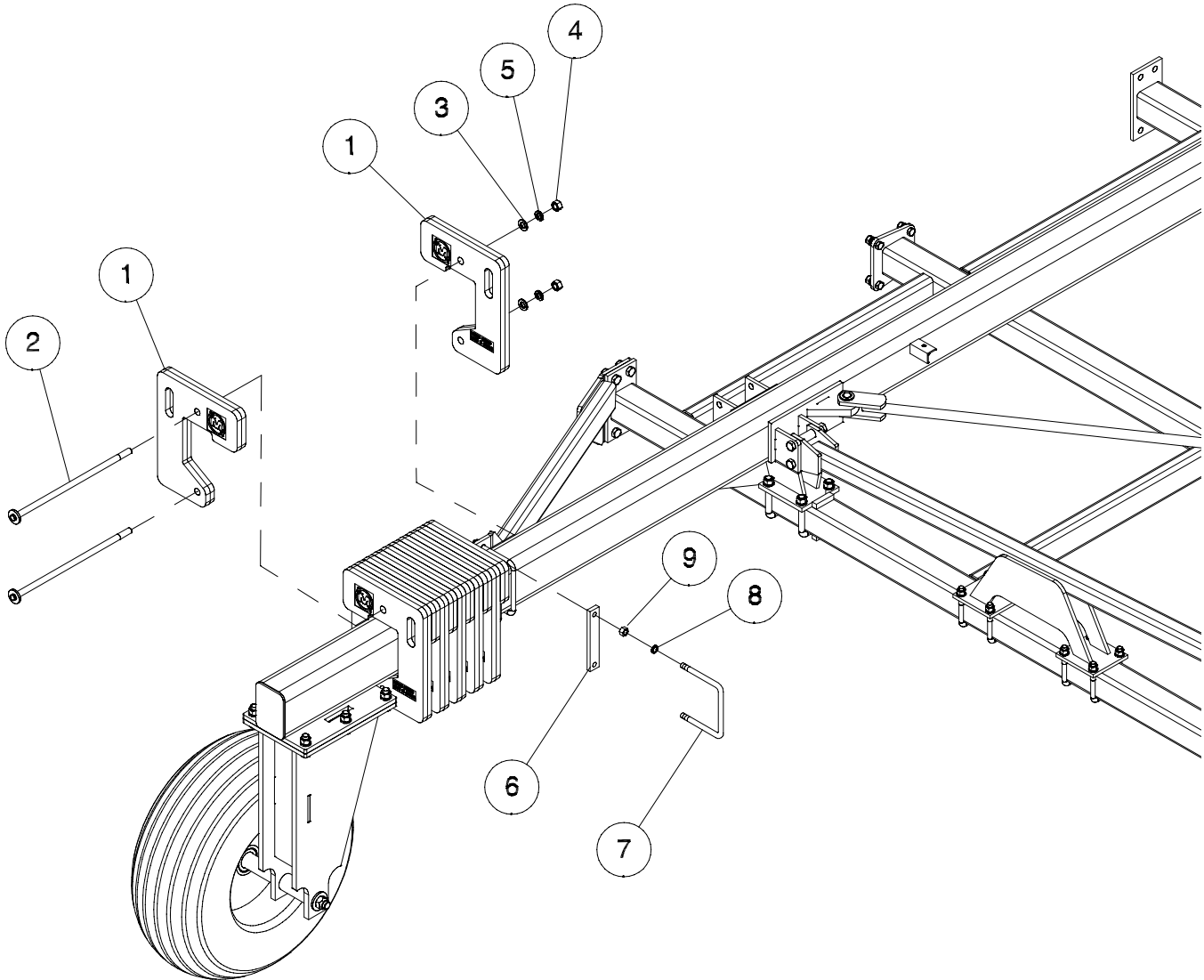

Note: Wrap Weights (1) around beam alternating left to right.

Item	Part No.	Description	Qty
1	N37523	Weight - 50lb	12
2	S44449	Rod - 3/4 Dia x 20 Lg	2
3	W-476	Flat Washer - 3/4.....	2
4	W-518	Hex Nut - 3/4.....	2
5	W-527	Lockwasher - 3/4.....	2
6	S47530	Plate - Weight Kit Stop	1
7	N33342	U-Bolt - 5/8 x 7 x 6 1/2	1
8	W-526	Lockwasher - 5/8.....	2
9	W-517	Hex Nut - 5/8.....	2
	S43741	Weight Kit (Includes all above items)	

Options Rear Tow Hitch

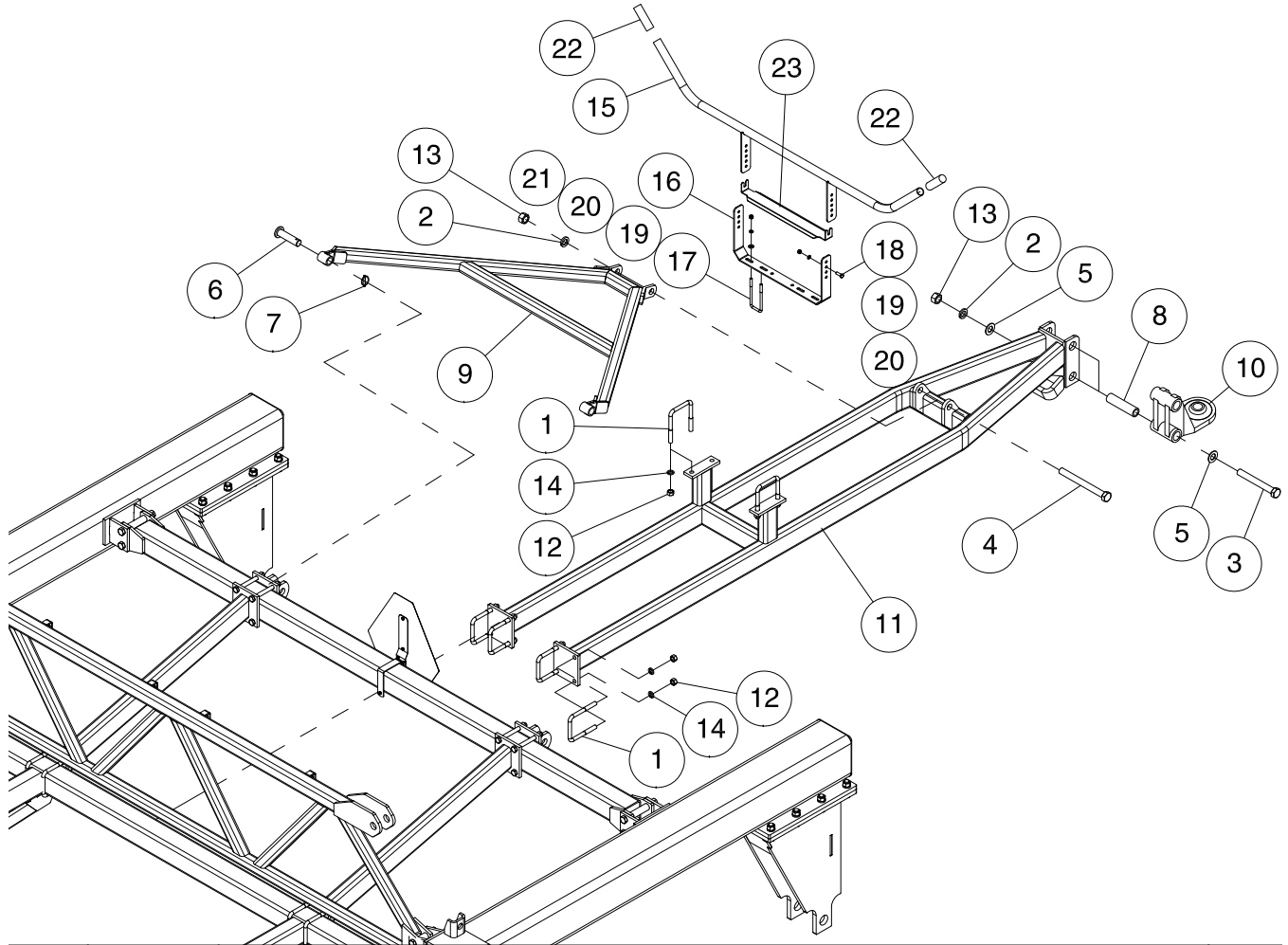

Item	Part No.	Description	Qty
1	C-219	U-Bolt - 5/8 x 4 x 5 9/16	6
2	C-705	Lockwasher - 1	3
3	C18597	Hex Bolt - 1 x 8 Lg.....	2
4	C18756	Hex Bolt - 1 x 10 Lg.....	1
5	F-4490	Washer - 1 1/16 ID x 1 7/8 OD x 1/4 Thick	4
6	N16226	Hitch Pin 1 1/8 Dia x 3 11/16 UL	2
7	N19307	Klik Pin - 1/4 x 1 3/4 Lg.....	2
8	S44370	Bushing - 1 1/2 OD x 1 ID	2
9	S55035	HD Brace - Hitch - (2 1/2 x 2 1/2 tubing)	1
10	S56135	Clevis - Hitch	1
11	S55040	Hitch Beam - Quad Steer - (3 x 4 Beam)	1
12	W-517	Hex Nut - 5/8.....	12
13	W-520	Hex Nut - 1	3
14	W-526	Lockwasher - 5/8.....	12
15	N56370	Bracket - Hose Holder.....	1
16	N56371	Strap - Hose Holder	1
17	N15097	U-Bolt - 3/8 x 2 x 5 UL.....	2
18	W-475	Hex Bolt - 3/8 x 1 Lg.....	4
19	W-514	Hex Nut - 3/8.....	8
20	W-523	Lockwasher - 3/8.....	8
21	D-5489	Flatwasher - 13/32 ID x 13/16 OD x 16 Ga	4
22	N37049	Rubber Grip	2
23	N69148	Support - Hydraulic Hoses	1
	S46506	HD Kit - Quad Steer - C2 - (Includes all items Except 15 - 23)	

Hitch Truss Kit - 61 and 71 Foot

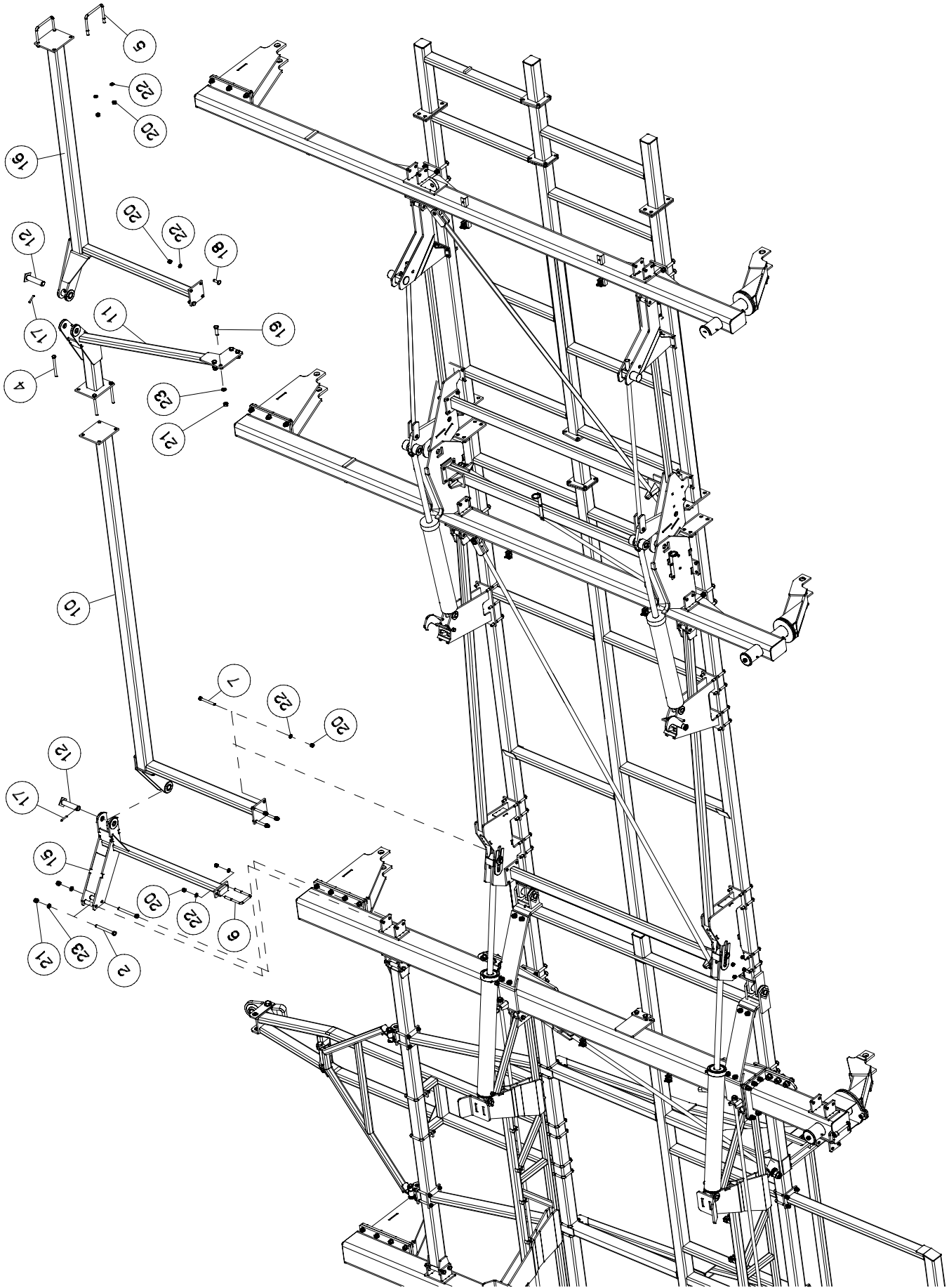

Hitch Truss Kit - 61 and 71 Foot

Item	Part No.	Description	Qty
1	C-219	U-Bolt - 5/8 x 4 x 5-9/16	4
2	C-3917	Hex Bolt - 3/4 x 7 Lg.....	4
3	D-4931	U-Bolt - 1/2 x 5 1/2.....	4
4	J12181	Hex Bolt - 5/8 x 7 Lg.....	8
5	N33342	U-Bolt - 5/8 x 7 x 6 1/2	4
6	N37512	U-Bolt - 5/8 x 4 x 6 1/4	2
7	S-1344	Hex Bolt - 5/8 x 5 1/2 Lg.....	12
8	S42905	Hitch Cross Member	1
9	*****		
10	S49822	Rear Truss - Inner To Main - 61 ft - Left.....	1
	S45936	Rear Truss - Inner To Main - 71 ft - Left.....	1
	S49824	Rear Truss - Inner To Main - 61 ft - Right	1
	S47520	Rear Truss - Inner To Main - 71 ft - Right	1
11	S45945	Rear Truss - Inner To Outer - 61 & 71 ft - Left	1
	S47521	Rear Truss - Inner To Outer - 61 & 71 ft - Right.....	1
12	S47518	Hinge Pin - 1 1/2 Dia x 5 5/8 UL	4
13	S47589	Spacer.....	2
14	*****		
15	S47634	Rear Main Hinge Assembly - 61 & 71 ft - Left	1
	S47637	Rear Main Hinge Assembly - 61 & 71 ft - Right.....	1
16	S49826	Rear Truss - Outer - 61 ft - Left	1
	S47635	Rear Truss - Outer 71' - Left	1
	S49828	Rear Truss - Outer - 61 ft - Right.....	1
	S47640	Rear Truss - Outer 71' - Right.....	1
17	T-5245	Spiral Pin - 3/8 x 2 1/2 Lg.....	6
18	T-5268	Carriage Bolt - 5/8 x 2 Lg	4
19	W-509	Hex Bolt - 3/4 x 2 1/2 Lg.....	8
20	W-517	Hex Nut - 5/8.....	34
21	W-518	Hex Nut - 3/4.....	12
22	W-526	Lockwasher - 5/8.....	34
23	W-527	Lockwasher - 3/4.....	12

Wing Lift Brace Kit - 81, 86 & 90 Foot

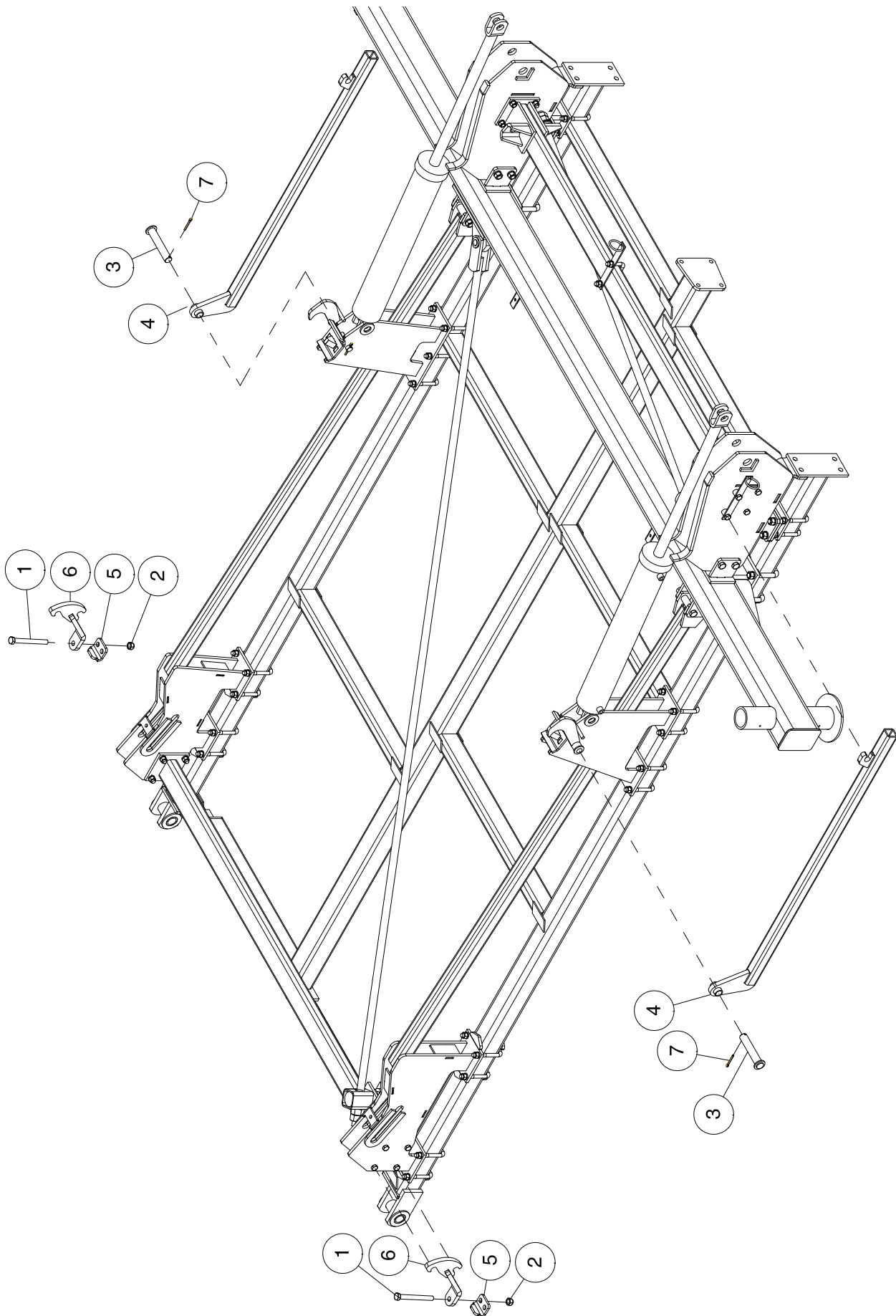

Wing Lift Brace Kit - 81, 86 & 90 Foot

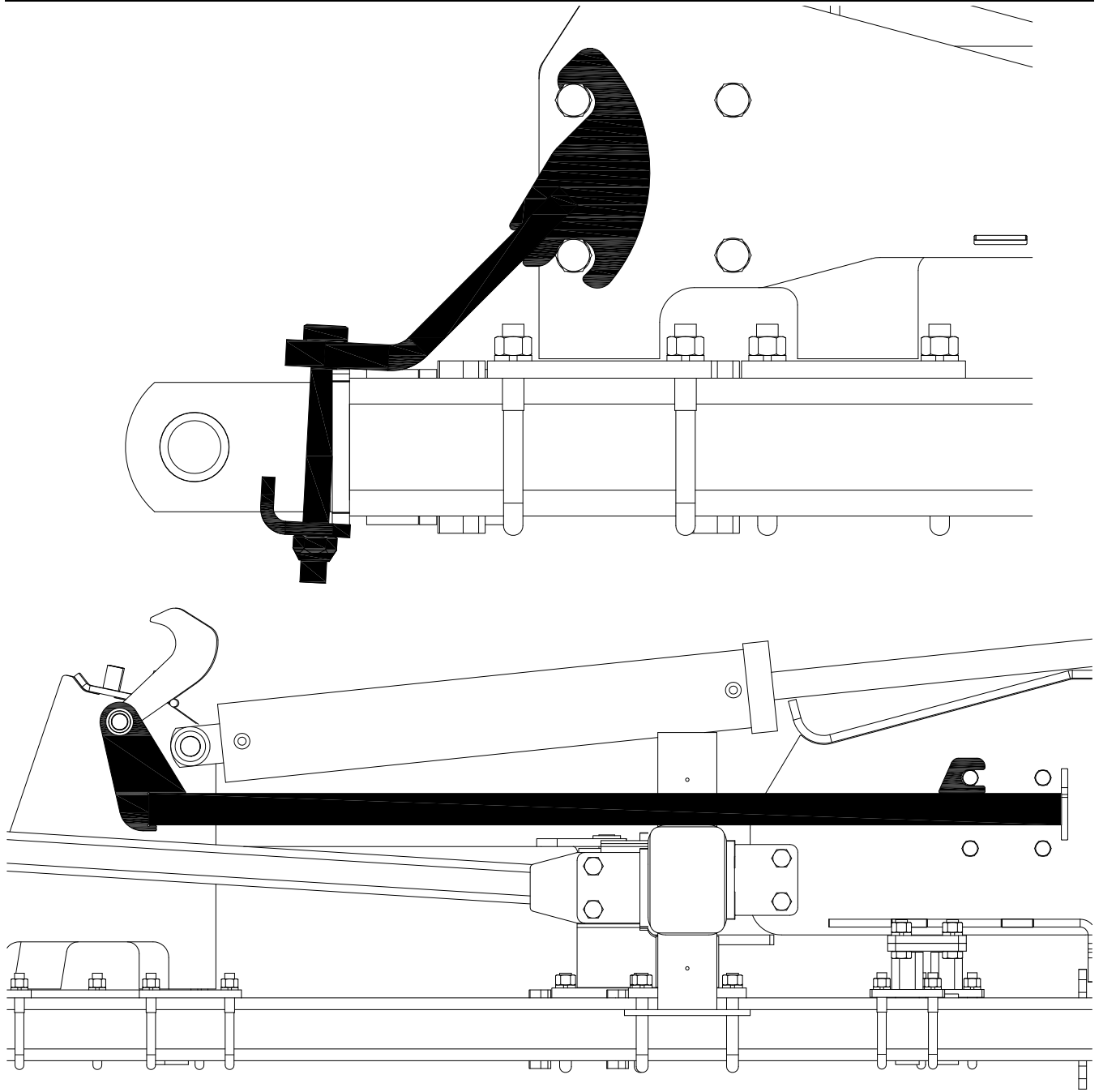

Item	Part No.	Description	Qty
1	C-3917	Hex Bolt - 3/4 x 7 LG.....	4
2	D-5273	Locknut - 3/4 Unitorque.....	4
3	C26844	Pin - 1 Dia x 6 1/8 UL.....	4
4	S55945	Outer Winglift Brace	4
5	S55299	Inner Hing Brace Backing Plate	4
6	S55335	Inner Hinge Brace	4
7	W-535	Cotter Pin - 1/4 x 1 1/2	4
	S55697	Winglift Update Kit - Includes Items (1, 2, 4, 5, & 6) applies to the entire Machine	
		Note: Quantiries are for the entire Machine	

Options Remote Clutch Switch - Prior to September 2012

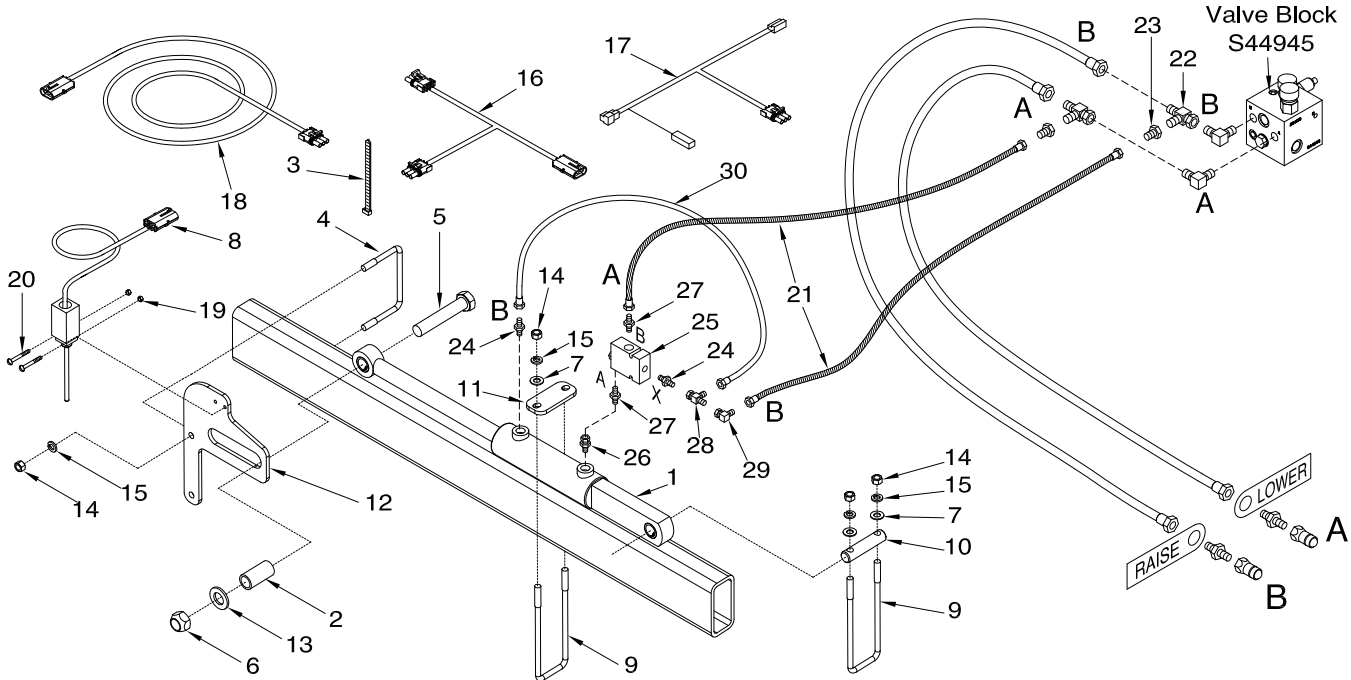

Item	Part No.	Description	Qty
1	C42912	Hydraulic Cylinder - 1 3/4 Bore x 3 1/4 Stroke	1
2	C33727	Spacer - 0.760 ID x 1 OD x 2 Lg	1
3	S13336	Tie Strap.....	6
4	D-4932	U-bolt - 3/8 Dia x 4 x 3	1
5	D-5256	Hex Bolt - 3/8 x 4 Lg.....	1
6	D-5273	Unitorque Locknut - 3/4.....	1
7	D-5489	Washer - 13/32 ID x 13/16 OD x 16 Ga.....	4
8	N32481	Work Switch	1
9	N34423	U-bolt - 3/8 Dia x 2 x 7	2
10	S44423	Pin - 3/4 Dia	1
11	S44426	Clamp.....	1
12	S44427	Mounting Plate - Work Switch	1
13	W-476	Flatwasher - 3/4	1
14	W-514	Hex Nut - 3/8	6
15	W-523	Lockwasher - 3/8.....	6
16	N32482	Connector - 'Y' Wire - Tow Behind ONLY - Weather Pak Ends	1
17	N32483	Connector - 'Y' Wire - Tow Between ONLY - Weather Pak Ends	1
18	N32457	Wire - Clutch Extension (Main) - 37 1/2 ft - Weather Pak Ends.....	1
19	N32102	Nut - 3/16	2
20	N32101	Stove Bolt - 3/16 x 1 1/2 Lg	2
21	S22406	Hydraulic Hose - 1/4 x 72 Lg - 9/16-18 FJIC.....	2
22	H18746	Tee - Swivel - (2) 7/8-14 MJIC x (1) 7/8-14 FJIC.....	2
23	F10384	Reducer - 9/16-18 MJIC x 7/8-14 FJIC	2
24	N29358	Connector - 9/16-18 MJIC x 9/16-18 MORB.....	2
25	S55320	Check Valve - Pilot Operated	1
26	S51156	Connector - 9/16-18 FJIC x 9/16-18 MORB - Swivel.....	1
27	C15348	Connector - 9/16-18 MJIC x 3/4-16 MORB	2
28	C-4403	Tee - (2) 9/16-18 MJIC x (1) 9/16-18 FJIC.....	1
29	S29967	90 Elbow - 9/16-18 FJIC x 9/16-18 MJIC	1
30	C-4467	Hydraulic Hose - 1/4 x 16 Lg - 9/16-18 FJIC.....	1
	S46924	Kit - Work Switch Pilot Check (Includes Items 24 to 30)	

Options Remote Clutch Switch - September 2012 to 2014

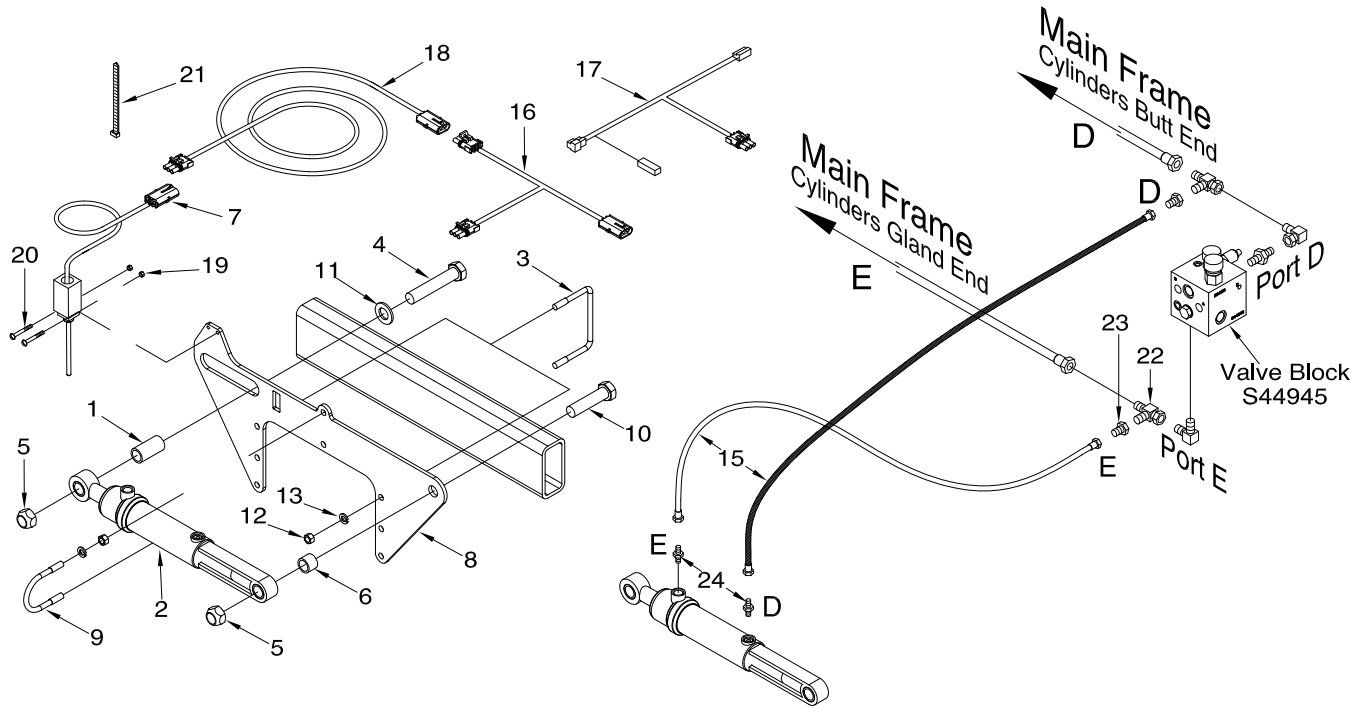

Item	Part No.	Description	Qty
1	C33727	Spacer - 0.760 ID x 1 OD x 2 Lg.....	1
2	C51153	Cylinder - 1 3/4 Bore x 4 Stroke.....	1
3	D-4932	U-Bolt - 3/8 x 4 x 3.....	2
4	D-5256	Hex Bolt - 3/4 x 4 Lg.....	1
5	D-5273	Locknut - 3/4 Unitorque.....	2
6	J11333	Spacer - 0.760 ID x 1 OD x 3/4 Lg.....	1
7	N32481	Work Switch.....	1
8	S50463	Mounting Plate - Work Switch.....	1
9	S50464	U-bolt - 3/8 x 2-1/16 x 3.....	1
10	W-63	Hex Bolt - 3/4 x 3 Lg.....	1
11	W-476	Flat Washer - 3/4.....	1
12	W-514	Hex Nut - 3/8.....	6
13	W-523	Lockwasher - 3/8.....	6
14	*****		
15	S22406	Hydraulic Hose - 1/4 x 72 Lg - 9/16-18 FJIC.....	2
16	N32482	Connector - 'Y' Wire - Tow Behind ONLY - Weather Pak Ends.....	1
17	N32483	Connector - 'Y' Wire - Tow Between ONLY - Weather Pak Ends.....	1
18	N32457	Wire - Clutch Extension (Main) - 37 1/2 ft - Weather Pak Ends.....	1
19	N32102	Nut - 3/16.....	2
20	N32101	Stove Bolt - 3/16 x 1 1/2 Lg.....	2
21	S13336	Tie Strap.....	6
22	H18746	Tee - Swivel - (2) 7/8-14 MJIC x (1) 7/8-14 FJIC.....	2
23	F10384	Reducer - 9/16-18 MJIC x 7/8-14 FJIC.....	2
24	N29358	Connector - 9/16-18 MJIC x 9/16-18 MORB.....	2

Options
Remote Clutch Switch - September 2014 to Present

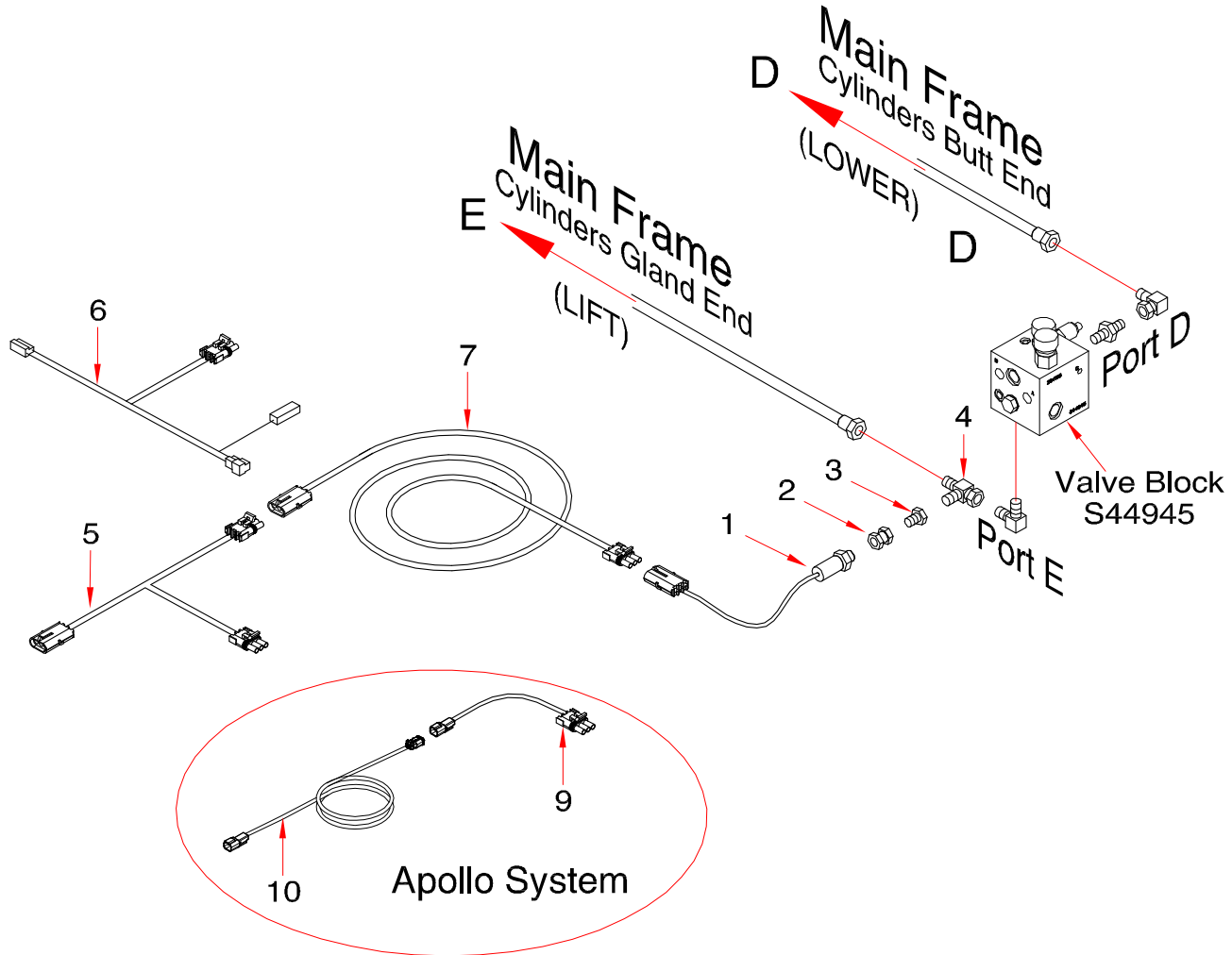

Item	Part No.	Description	Qty
Ground Drive and Base X20 and X30 Systems			
1	S56558	Pressure Switch	1
2	S42998	Connector - 1/4 FNPT x 9/16-18 FJIC	1
3	F10384	Connector - 9/16-18 MJIC x 7/8-14 FJIC	1
4	H18746	Tee - Swivel - (2) 7/8-14 MJIC x (1) 7/8-14 FJIC.....	1
5	N32482	Connector - 'Y' Wire - Tow Behind ONLY - Weather Pak Ends.....	1
6	N32483	Connector - 'Y' Wire - Tow Between ONLY - Weather Pak Ends	1
7	N32457	Wire - Clutch Extension (Main) - 37 1/2 ft - Weather Pak Ends.....	1
8	S13336	Tie Strap.....	4
	S54297	Tow Between - Work Switch Kit (Includes Items 1, 2, 3, 4, 6, 7, and 8)	
	S54298	Tow Behind - Work Switch Kit (Includes Items 1, 2, 3, 4, 5, 7, and 8)	
Apollo System - 2016			
1	S56558	Pressure Switch	1
2	S42998	Connector - 1/4 FNPT x 9/16-18 FJIC	1
3	F10384	Connector - 9/16-18 MJIC x 7/8-14 FJIC	1
4	H18746	Tee - Swivel - (2) 7/8-14 MJIC x (1) 7/8-14 FJIC.....	1
9	N60323	Harness Adaptor - Pressure Work Switch.....	1
10	N59010	Harness - Work Switch - 5 m.....	1

Options Remote Clutch Switch

The "Y" adaptor and extension cable attach to the Air Cart clutch harness as illustrated below.

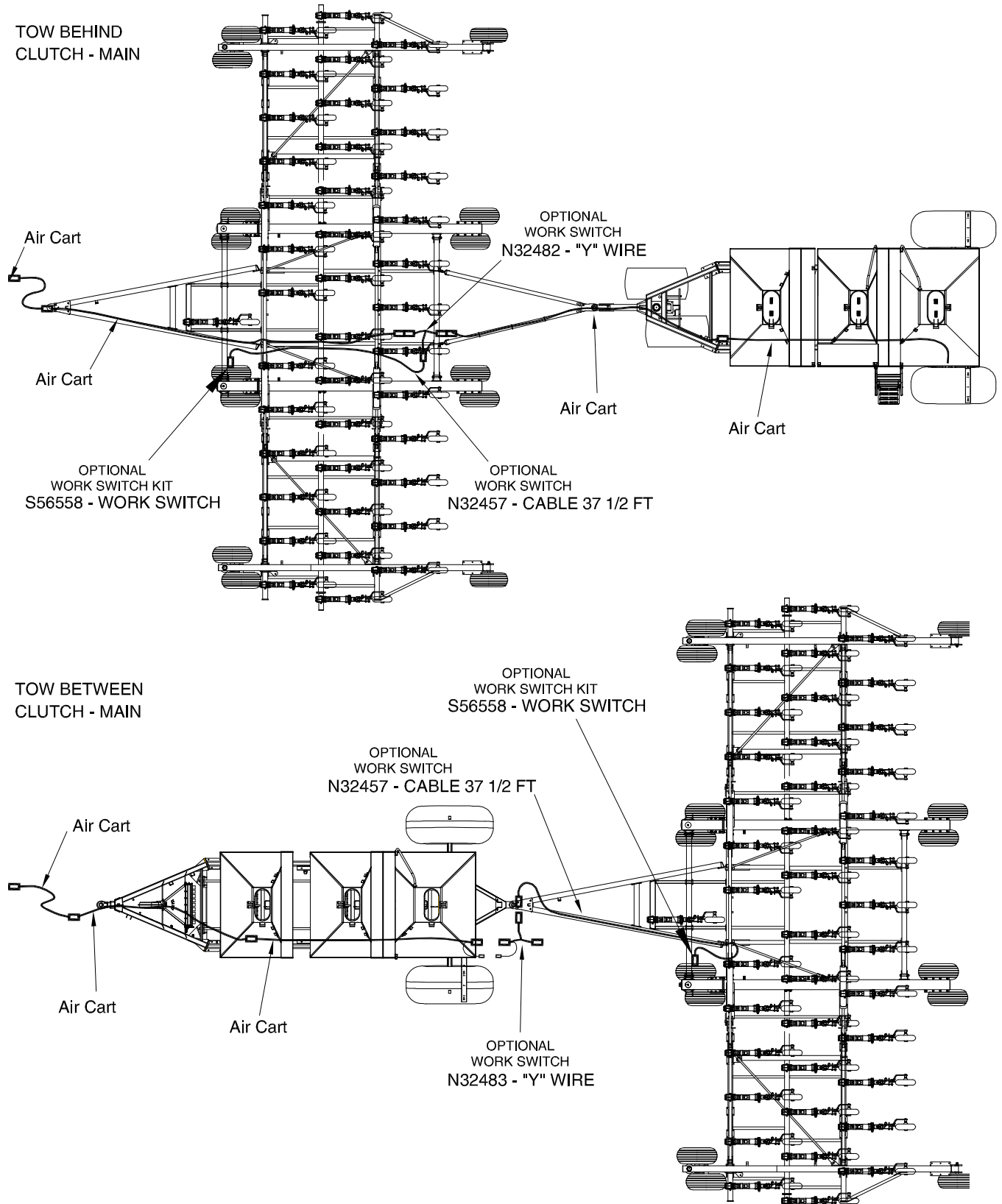

Notes

Section 9: Optional 4th Row Kits

Section Contents

4 th Row - Wing Frame - 41 ft to 71 ft	9-2
4 th Row - OuterWing - 61 ft and 71 ft	9-3
4 th Row - 80 ft	9-4
4 th Row - 90 ft	9-6
4 th Row - Hydraulics	9-8

4th Row - Wing Frame - 41 ft to 71 ft

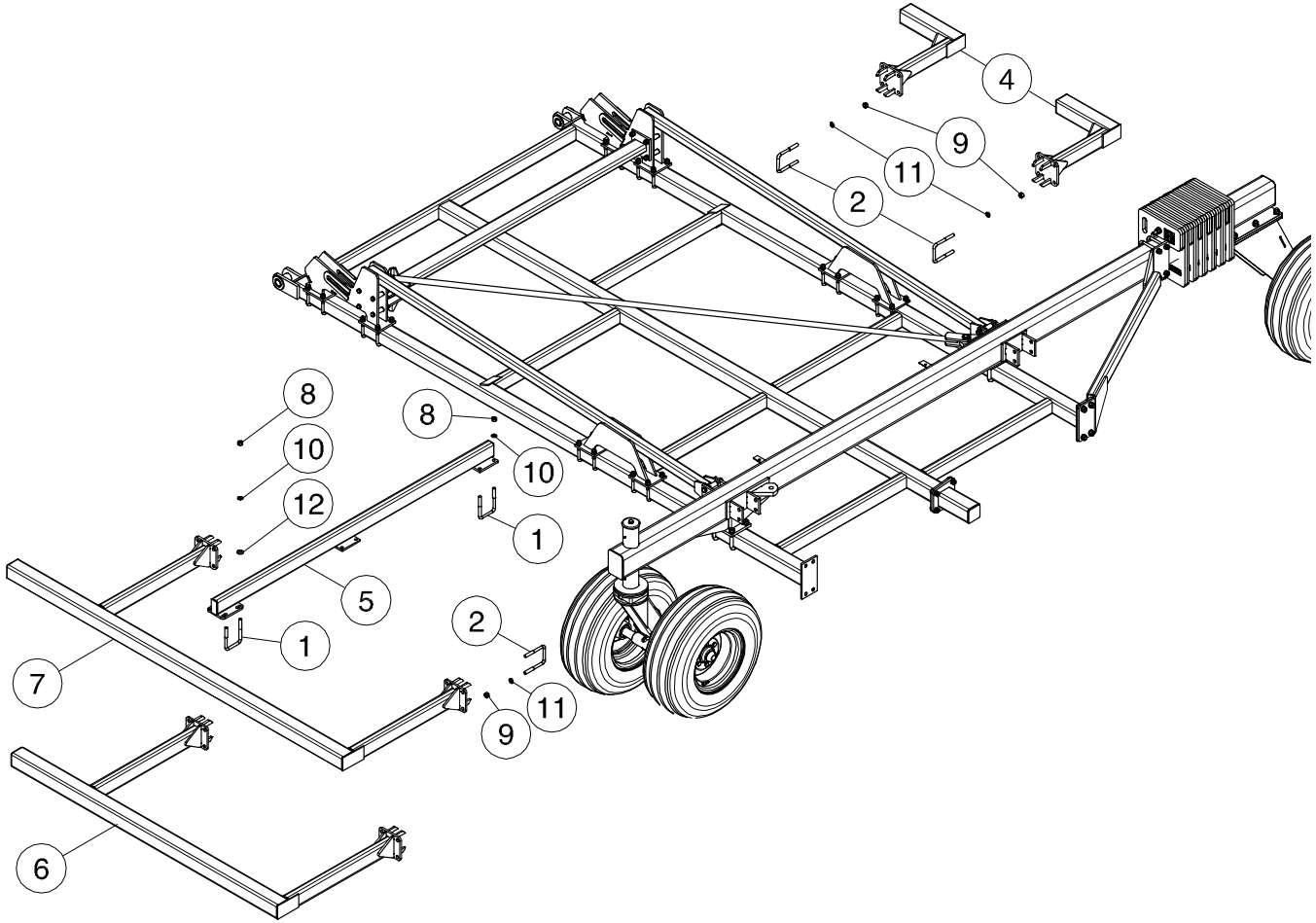

Item	Part No.	Description	Qty
1	C-219	U-Bolt - 5/8 x 4 x 5 9/16	12
2	C-5561	U-Bolt - 3/4 x 4 x 5 9/16	42
3	S42963	Extension Frame	2
4	S56720	Extension Frame	4
5	S56724	Mounting Arm.....	1
6	S45265	Trip Mounting Frame - 41Ft, 51 Ft & 61 Ft	2
7	S45264	Trip Mounting Frame - 71 Ft	2
8	W-517	Hex Nut - 5/8	24
9	W-518	Hex Nut - 3/4.....	84
10	W-526	Lockwasher - 5/8.....	24
11	W-527	Lockwasher - 3/4.....	84
12	W-629	Flat Washer - 5/8.....	8

4th Row - OuterWing - 61 ft and 71 ft

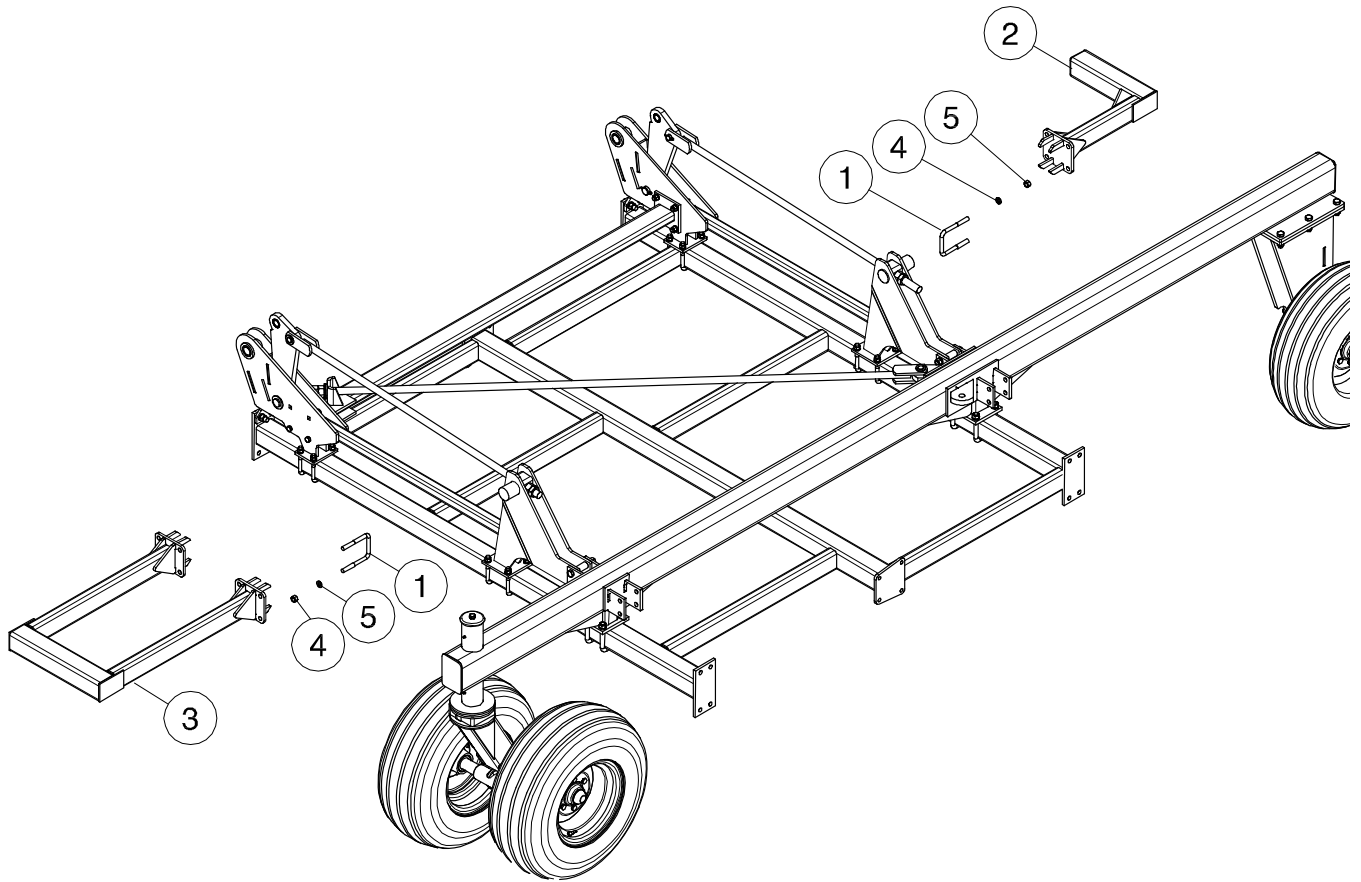

Item	Part No.	Description	Qty
1	C-5561	U-Bolt - 3/4 x 4 x 5 9/16	12
2	S56720	Extension Frame	1
3	S42963	Extension Frame	1
4	W-518	Hex Nut - 3/4	24
5	W-527	Lockwasher - 3/4.....	24

4th Row - 80 ft

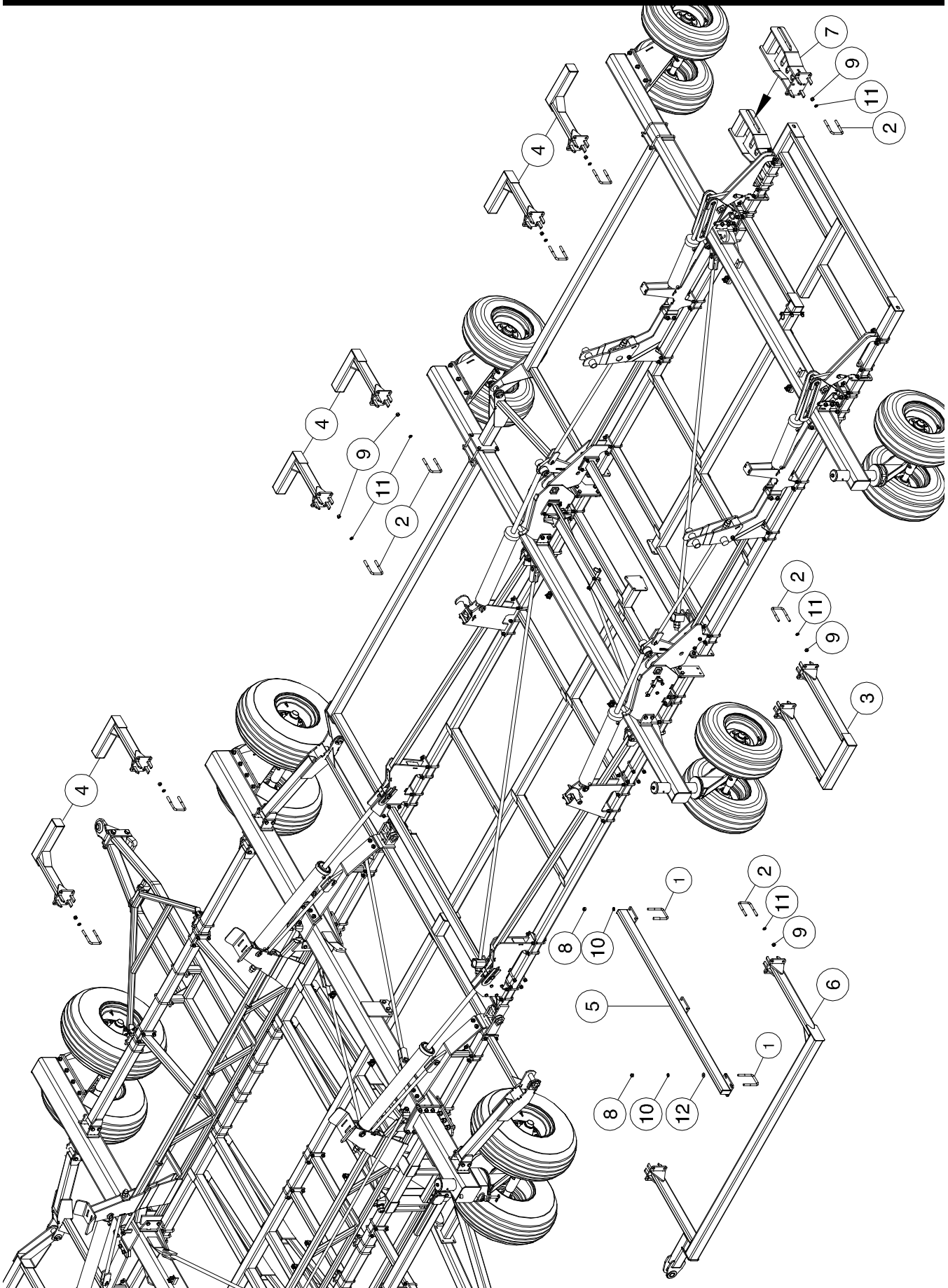

4th Row - 80 ft

Item	Part No.	Description	Qty
1	C-219	U-Bolt - 5/8 x 4 x 5 9/16	12
2	C-5561	U-Bolt - 3/4 x 4 x 5 9/16	42
3	S42963	Extension Frame	2
4	S56720	Extension Frame	10
5	S56724	Mounting Arm.....	2
6	S59855	Trip Mounting Frame - 80 ft to 90 ft.....	2
7	S59865	Stub - Rear Offset	2
8	W-517	Hex Nut - 5/8	24
9	W-518	Hex Nut - 3/4.....	84
10	W-526	Lockwasher - 5/8.....	24
11	W-527	Lockwasher - 3/4.....	84
12	W-629	Flat Washer - 5/8.....	8
	S42969	Hyd Hose - 3/8 x 36 Lg w/ #6 9/16-18 FJIC.....	24
	S44353	Hyd Hose - 3/8 x 48 Lg w/ #6 9/16-18 FJIC.....	12
	F-3867	90 Elbow - 9/16-18 MJIC.....	12
	H18269	Connector - 9/16-18 MJIC.....	24
	S54767	Kit - 4th Rank - 80 FT	

4th Row - 90 ft

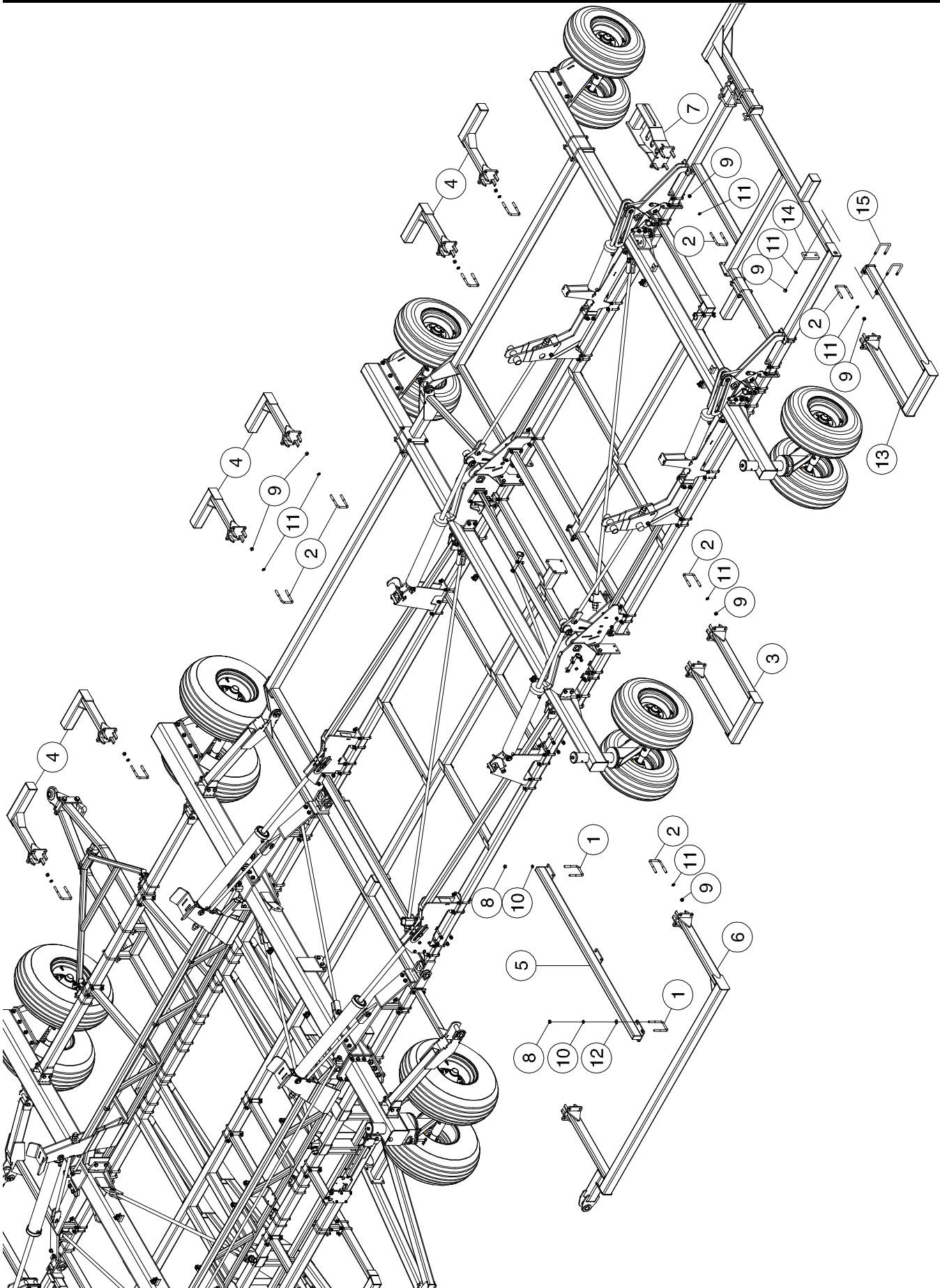

4th Row - 90 ft

Item	Part No.	Description	Qty
1	C-219	U-Bolt - 5/8 x 4 x 5 9/16	12
2	C-5561	U-Bolt - 3/4 x 4 x 5 9/16	42
3	S42963	Extension Frame	2
4	S56720	Extension Frame	10
5	S56724	Mounting Arm.....	2
6	S59855	Trip Mounting Frame - 80 ft to 90 ft.....	2
7	S59865	Stub - Rear Offset	2
8	W-517	Hex Nut - 5/8	24
9	W-518	Hex Nut - 3/4.....	92
10	W-526	Lockwasher - 5/8.....	24
11	W-527	Lockwasher - 3/4.....	92
12	W-629	Flat Washer - 5/8.....	8
13	S59850	Trip Mounting Frame - Outer Frame - 90 ft.....	2
14	C29194	Clamp Plate	4
15	C26447	U-Bolt - 3/4 x 4 x 7 UL.....	4
	S42969	Hyd Hose - 3/8 x 36 Lg w/ #6 9/16-18 FJIC.....	24
	S44353	Hyd Hose - 3/8 x 48 Lg w/ #6 9/16-18 FJIC.....	12
	F-3867	90 Elbow - 9/16-18 MJIC.....	12
	H18269	Connector - 9/16-18 MJIC.....	24
	S54768	Kit - 4th Rank - 80 FT	

4th Row - Hydraulics

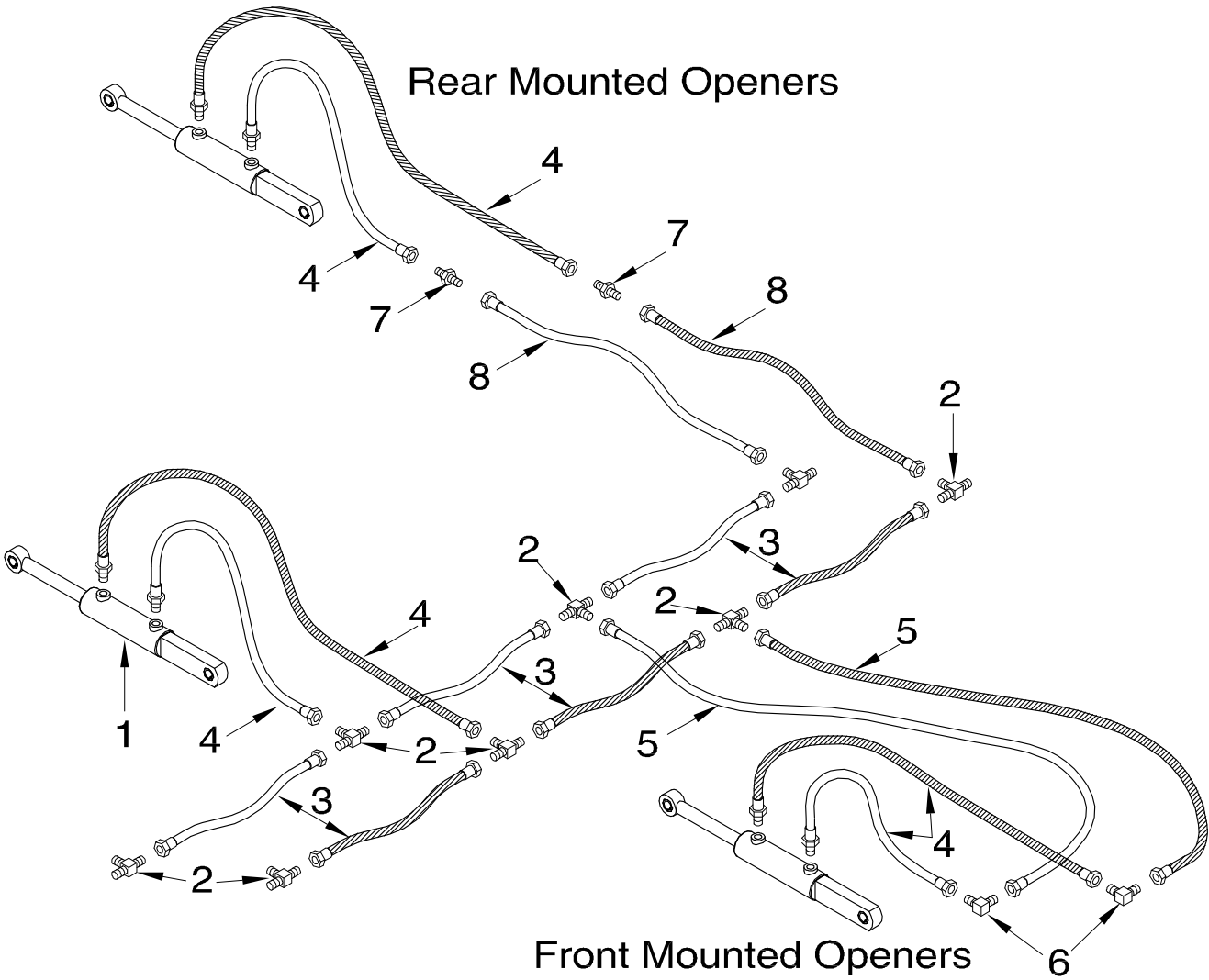

Item	Part No.	Description	Qty
1	C42912	Cylinder	AsReq
2	C-4393	Tee - (3) 9/16-18 MJIC.....	AsReq
3	S42969	Hyd Hose - 3/8 x 36 Lg w/ #6 9/16-18 FJIC.....	AsReq
4	S44352	Hyd Hose - 1/4 x 24 Lg w/ #6 9/16-18 FJIC x #6 9/16-18 MORB	AsReq
5	S44353	Hyd Hose - 3/8 x 48 Lg w/ #6 9/16-18 FJIC - Per Opener moved Forward.....	2
6	F-3867	90 Elbow - 9/16-18 MJIC - Per Opener moved Forward.....	2
7	H18269	Connector - 9/16-18 MJIC - Per Opener moved Rearward	2
8	S42969	Hyd Hose - 3/8 x 36 Lg w/ #6 9/16-18 FJIC - Per Opener moved Rearward	2
9	D-4838	Nylon Tie Strap - 1/2 x 14 1/2 Lg.....	AsReq
9A	D-4951	Nylon Tie Strap - 7 3/8 Lg.....	AsReq
(Kit Includes Items 5 and 6 for each Opener moved Forward) (Kit Includes Items 7 and 8 for each Opener moved Rearward)			

Section 10: Lighting and Safety Signs

Section Contents

Lighting	10-2
25 and 31 Ft Contour Air Drill.....	10-2
41 to 90 Ft Contour Air Drill.....	10-4
Safety Signs.....	10-6
25 and 31 Ft Contour Air Drill.....	10-6
41, 47 and 51 Ft Contour Air Drill.....	10-7
61 and 71 Ft Contour Air Drill.....	10-8
80, 86 and 90 Ft Contour Air Drill.....	10-9

Lighting 25 and 31 Ft Contour Air Drill

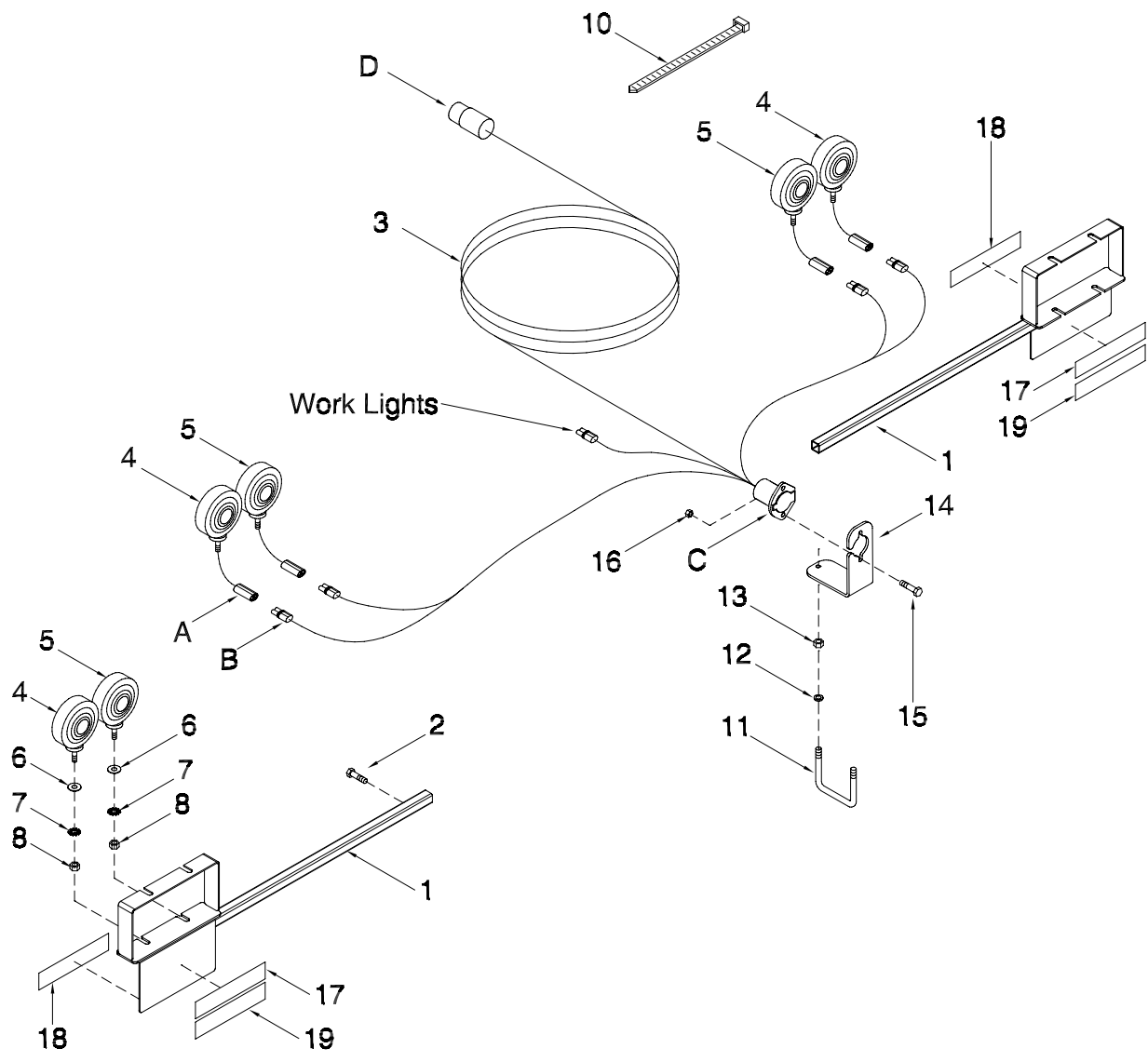

Lighting - Contour Air Drill - 25 and 31 Ft

Item	Part No.	Description	Qty
1	C31498	Tube - Mounting - Main - Lighting.....	2
2	W-484	Hex Bolt - 1/2 x 1.....	2
3	C31438	Wiring Harness - Safety Lights.....	1
4	C32765	Light - Amber.....	2
5	C32766	Light - Red	2
6	W-539	Flatwasher - 1/2.....	4
7	D-5280	Starwasher - 1/2.....	4
8	W-516	Hex Nut - 1/2.....	4
9			
10	D-4951	Nylon Tie Strap - 7 3/8 lg.....	20
	S13336	Nylon Tie Strap - 28 1/4 lg.....	10
11	N34025	U-Bolt - 3/8 x 5 x 8	1
12	W-523	Lockwasher - 3/8.....	2
13	W-514	Hex Nut - 3/8.....	2
14	N32001	Bracket - Mounting	1
15	N29048	Carriage Head Bolt - 5/16 x 1 lg.....	2
16	D-5278	Serrated Nut - 5/16.....	2
17	N34476	Reflector - Red	2
18	N34477	Reflector - Amber	2
19	N34478	Reflector - Orange.....	2
	C32761	Red Acrylic Lens	
	C32762	Amber Acrylic Lens	
	C32515	Bulb - #1156 (Amber Light)	
	C32656	Bulb - #1157 (Red Light)	
A	C32681	Receptacle Connector Assembly - GRAY - 2 Pin	
B	C32682	Plug Connector Assembly - GRAY - 2 Pin	
C	C32686	Connector Assembly - 7 Pin Socket	
	C32684	Interior - Socket - 7 Pin Connector	
	C32685	Protective Boot - Socket - 7 Pin Connector	
D	C32690	Connector Assembly - 7 Pin Plug (Complete with Cable Protector Spring)	
	C32688	Interior - Plug - 7 Pin Connector	
	C32689	Cable Protector Spring - Plug - 7 Pin Connector	
	N46139	Kit Lighting - Contour Air Drill ORDER KIT THROUGH WHOLE GOODS ONLY	

Lighting 41 to 90 Ft Contour Air Drill

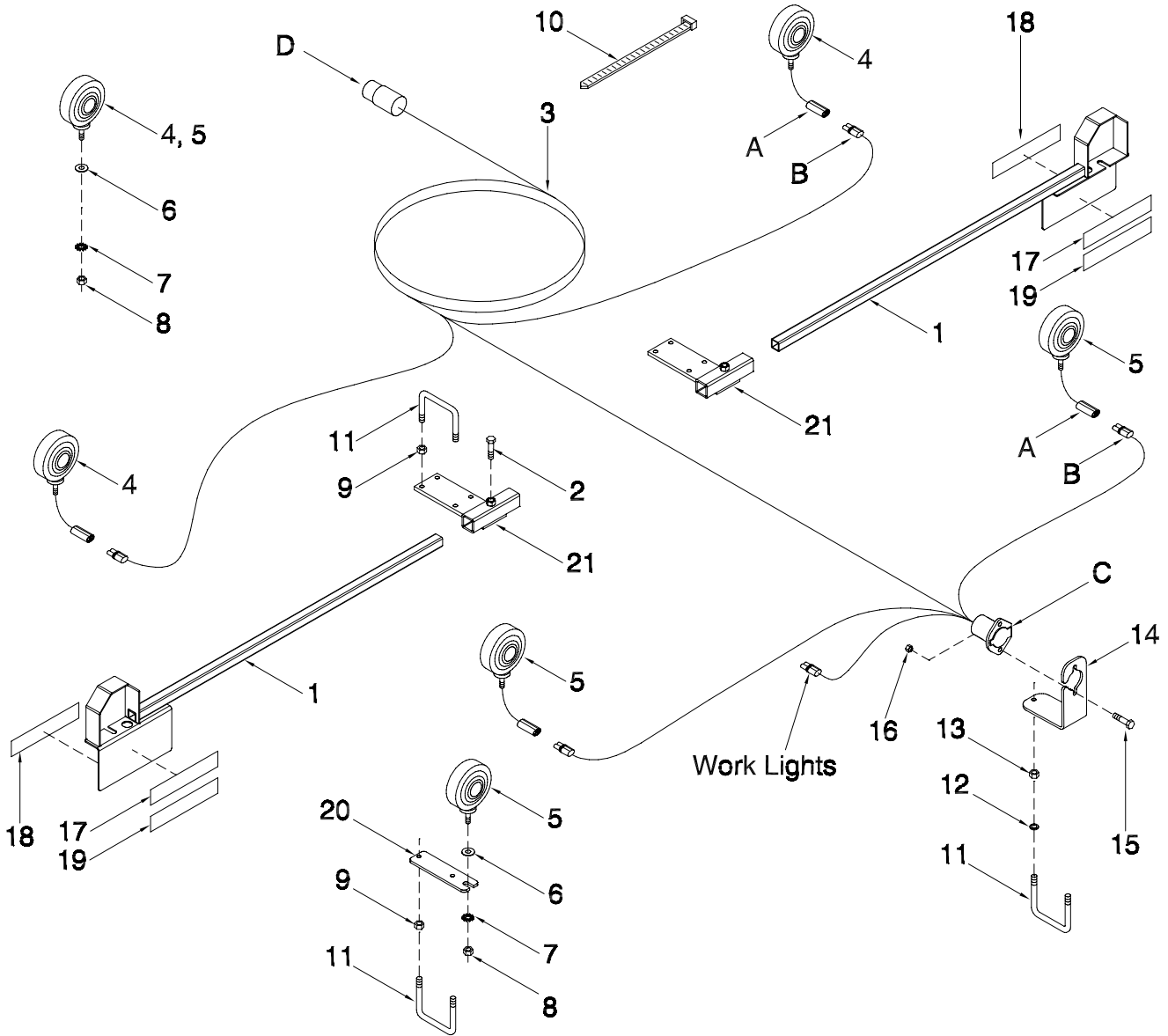

Lighting - Contour Air Drill - 41 to 90 Ft

Item	Part No.	Description	Qty
1	S34464	Tube - Mounting - Main - Lighting.....	2
2	W-484	Hex Bolt - 1/2 x 1.....	2
3	S34466	Wiring Harness - Safety Lights.....	1
4	C32765	Light - Amber.....	2
5	C32766	Light - Red	2
6	W-539	Flatwasher - 1/2.....	4
7	D-5280	Starwasher - 1/2.....	4
8	W-516	Hex Nut - 1/2.....	4
9	D-5279	Flange Locknut - 3/8	12
10	D-4951	Nylon Tie Strap - 7 3/8 lg.....	20
	S13336	Nylon Tie Strap - 28 1/4 lg.....	10
11	N15098	U-Bolt - 3/8 x 4 x 5	7
12	W-523	Lockwasher - 3/8.....	2
13	W-514	Hex Nut - 3/8.....	2
14	N32001	Bracket - Mounting	1
15	N29048	Carriage Head Bolt - 5/16 x 1 lg.....	2
16	D-5278	Serrated Nut - 5/16.....	2
17	N34476	Reflector - Red	2
18	N34477	Reflector - Amber	2
19	N34478	Reflector - Orange.....	2
20	S34465	Bracket - Mounting.....	2
21	S44325	Bracket - Mounting.....	2
	C32761	Red Acrylic Lens	
	C32762	Amber Acrylic Lens	
	C32515	Bulb - #1156 (Amber Light)	
	C32656	Bulb - #1157 (Red Light)	
A	C32681	Receptacle Connector Assembly - GRAY - 2 Pin	
B	C32682	Plug Connector Assembly - GRAY - 2 Pin	
C	C32686	Connector Assembly - 7 Pin Socket	
	C32684	Interior - Socket - 7 Pin Connector	
	C32685	Protective Boot - Socket - 7 Pin Connector	
D	C32690	Connector Assembly - 7 Pin Plug (Complete with Cable Protector Spring)	
	C32688	Interior - Plug - 7 Pin Connector	
	C32689	Cable Protector Spring - Plug - 7 Pin Connector	
	N43681	Kit Lighting - Contour Air Drill ORDER KIT THROUGH WHOLE GOODS ONLY	

**Safety Signs
25 and 31 Ft Contour Air Drill**

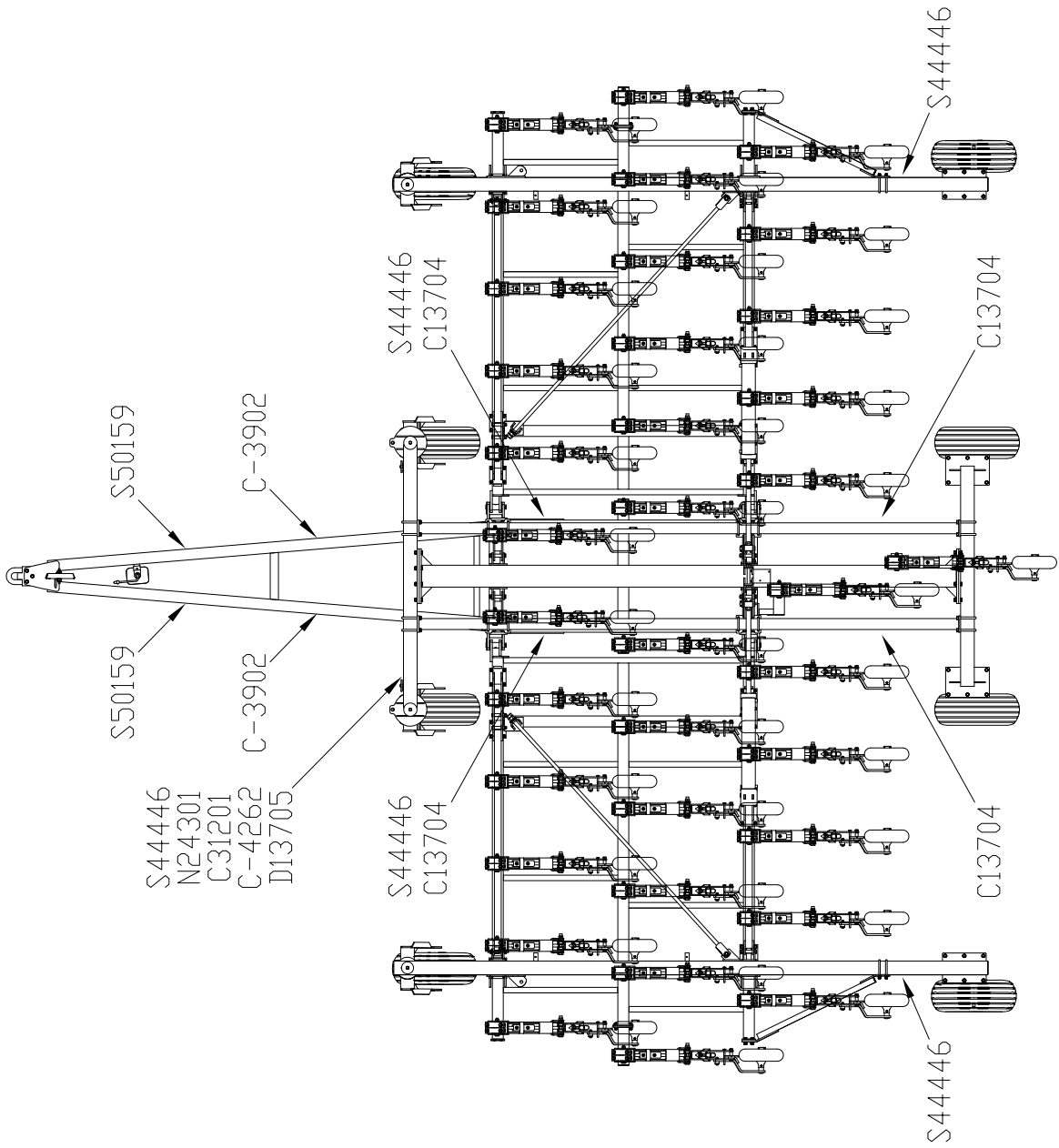

Safety Signs 41, 47 and 51 Ft Contour Air Drill

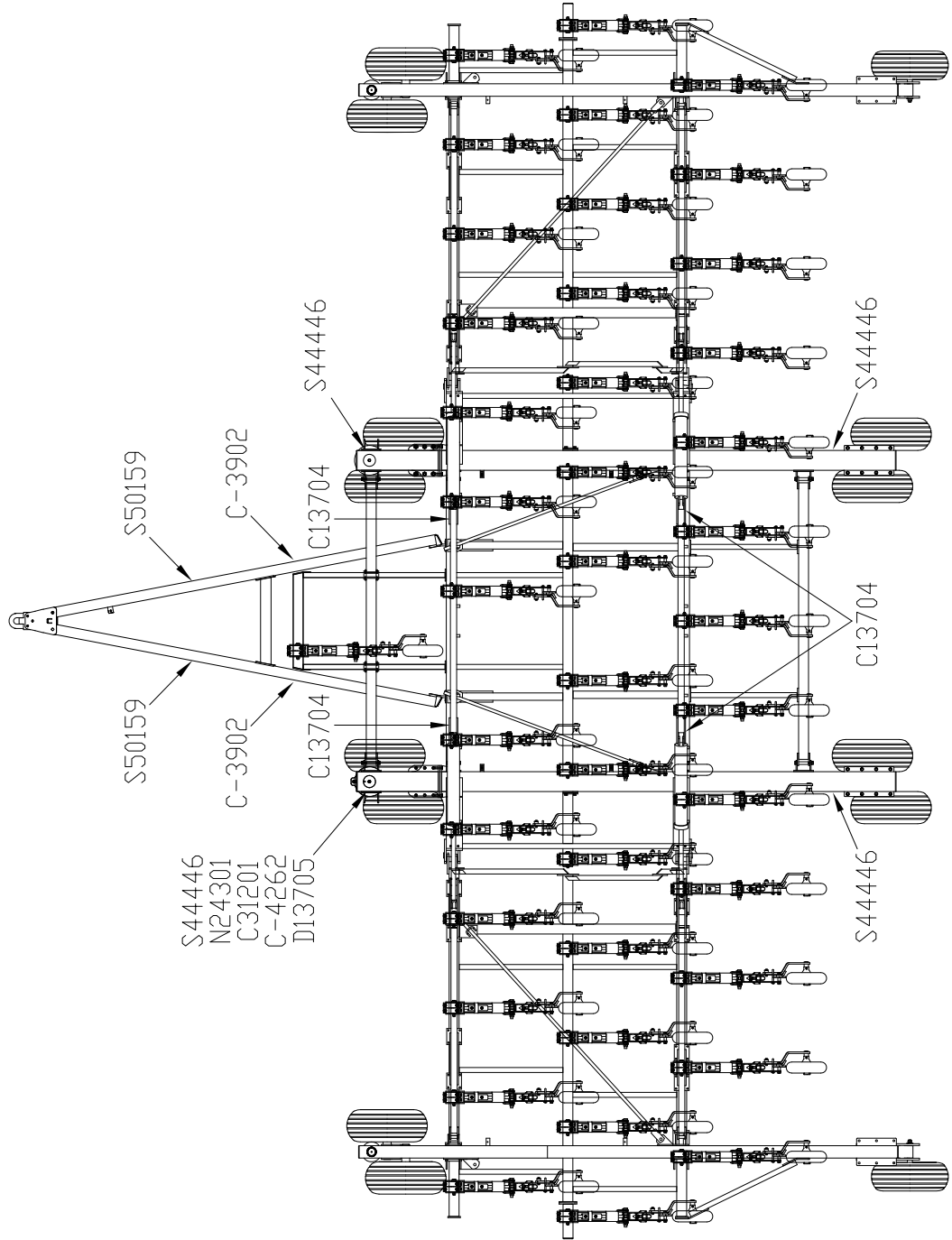

Safety Signs 80, 86 and 90 Ft Contour Air Drill

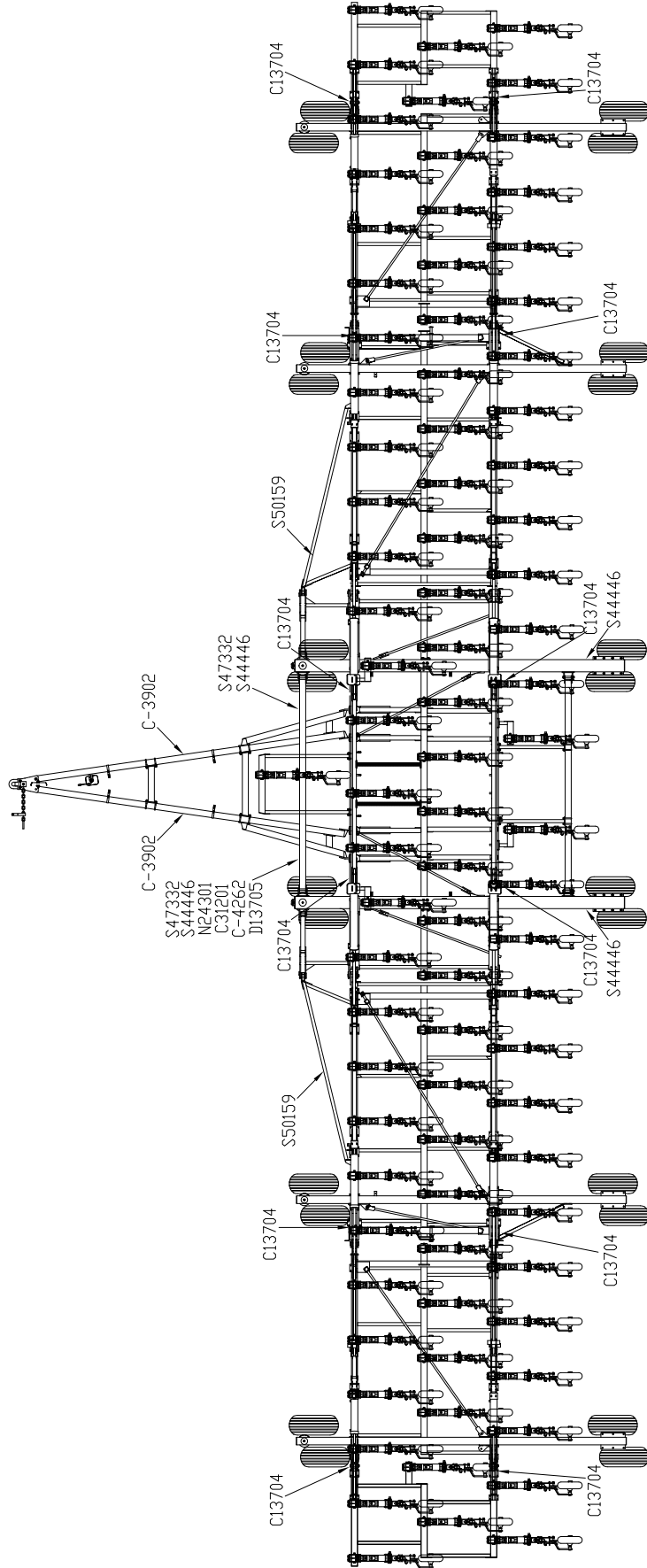

Notes

Index

11576 1-5, 1-9	21, 1-37, 8-5, 1-39	11, 4-13, 4-15, 4-17, 4-37, 4-39, 4-41, 4-43, 4-45, 4-47, 4-49, 4-51, 4-53, 4-55	19, 4-21, 4-23, 4-25, 4-27, 4-29, 4-31, 4-32, 4-35
A	C-3918 4-3, 4-5, 4-7, 4-9, 4-11, 4-13, 4-15, 4-17, 4-37, 4-39, 4-41, 4-43, 4-45, 4-47, 4-49, 4-51, 4-53, 4-55	C14835 4-11, 4-13, 4-15, 4-17	C26082 2-3, 2-4, 2-5, 2-9, 2-11
A28898 3-30	C-3919 1-13, 1-24, 1-27, 1-31, 1-33, 1-37, 1-39, 1-41, 1-43, 1-45, 1-47, 1-49, 1-51, 1-53, 1-55	C14840 4-3, 4-5, 4-7, 4-9, 4-11, 4-13, 4-15, 4-17, 4-21, 4-23, 4-25, 4-27, 4-29, 4-31, 4-32, 4-35, 4-56, 4-57	C26085 2-9, 2-11
B	C-4262 4-21, 4-23, 4-25, 4-27, 4-29, 4-31	C14901 4-37, 4-39, 4-41, 4-43, 4-45, 4-47, 4-49, 4-51, 4-53, 4-55	C26086 2-3, 2-5, 2-9, 2-11
BW-11 1-11, 1-13	C-4393 4-7, 9-8, 4-9, 4-11, 4-13, 4-15, 4-17, 4-37, 4-39, 4-41, 4-43, 4-47, 4-49, 4-51, 4-53, 4-55, 4-45	C15318 4-31	C26190 5-3
C	C-4394 4-37, 4-39, 4-41, 4-43, 4-45, 4-47, 4-49, 4-51, 4-53, 4-55	C15319 4-23, 4-29, 7-35, 4-35	C26259 4-9, 4-13
C-219 1-3, 1-9, 1-13, 1-17, 1-19, 1-20, 1-21, 1-23, 7-25, 1-30, 1-33, 1-41, 1-43, 1-45, 1-47, 1-49, 1-53, 1-7, 1-35, 1-39, 1-51, 7-7, 7-9, 7-11, 7-13, 7-15, 7-19, 7-21, 1-22, 7-29, 7-31, 7-33, 1-55, 8-3, 8-5, 7-23, 9-2, 9-5, 9-7	C-4401 4-37, 4-39, 4-41, 4-43, 4-45, 4-47, 4-49, 4-51, 4-53, 4-55	C15348 4-3, 4-5, 4-7, 8-8, 4-9, 4-11, 4-13, 4-15, 4-17, 4-37, 4-39, 4-41, 4-43, 4-47, 4-49, 4-51, 4-53, 4-55, 4-45	C26266 2-3, 2-5, 2-9, 2-11
C-507 1-7, 1-9, 1-20, 1-21	C-4403 4-5, 8-8, 4-11, 4-13, 4-15, 4-17, 4-37, 4-39, 4-41, 4-43, 4-47, 4-49, 4-51, 4-53, 4-55, 4-45	C15767 1-17, 1-20, 1-21, 1-37, 1-39	C26321 1-3, 1-5, 1-7, 1-9, 1-10
C-508 1-37, 1-39	C-4404 4-25	C15768 1-57	C26337 4-3, 4-5, 4-7, 4-9, 4-11, 4-13, 4-21, 4-23, 4-25, 4-56
C-695 1-13, 1-15, 1-17, 1-27, 1-31, 1-33, 7-35, 1-37, 1-39, 1-41, 1-43, 1-45, 1-47, 1-49, 1-51, 1-53, 1-55	C-4438 1-3, 1-5, 1-7, 1-9, 1-10	C16609 2-2, 2-3, 2-4, 2-5	C26339 4-5
C-705 1-13, 1-14, 1-19, 8-3	C-4467 8-8	C16611 2-8, 2-9, 2-10, 2-11, 2-12, 2-13	C26341 4-21, 4-23, 4-25, 4-27, 4-29, 4-56, 4-57
C-852 1-39, 1-41, 1-43, 1-45, 1-58	C-4468 4-5, 4-21, 4-23, 4-25, 4-27, 4-29, 4-31	C16637 5-2	C26343 4-3, 4-5
C-1429 1-23	C-4552 4-11, 4-13, 4-15, 4-17, 4-37, 4-39, 4-41, 4-43, 4-47, 4-49, 4-51, 4-53, 4-55	C16652 4-11, 4-13, 4-37, 4-39, 4-41, 4-43, 4-45, 4-47, 4-49, 4-51, 4-53, 4-55	C26347 4-11, 4-13, 4-15, 4-17
C-1463 2-8, 2-9, 2-10, 2-11, 2-13	C-4569 4-21, 4-25, 1-43, 1-47, 1-49, 1-53, 4-23, 4-27, 4-29, 4-31, 1-37, 1-39, 4-41, 4-47, 4-49, 4-51, 4-53, 4-55	C17348 2-2, 2-3, 2-4, 2-5, 2-6, 2-7, 2-8, 2-9, 2-10, 2-11, 2-12, 2-13	C26436 4-11, 4-15, 4-13
C-1471 4-59	C-4698 4-3, 4-5, 4-7, 4-9, 4-11, 4-13, 4-15, 4-17, 4-37, 4-39, 4-41, 4-43, 4-45, 4-47, 4-49, 4-51, 4-53, 4-55	C17355 2-2, 2-3, 2-4, 2-5, 2-6, 2-7	C26437 5-2
C-1521 2-8, 2-9, 2-10, 2-11, 2-13	C-5561 1-13, 1-15, 1-17, 1-19, 1-27, 1-31, 1-37, 1-41, 1-43, 1-45, 9-2, 9-3, 9-7, 1-39	C18531 1-3, 1-7, 1-10	C26438 4-7, 4-9
C-1522 2-8, 2-9, 2-10, 2-11, 2-13	C12375 2-13	C18597 1-13, 8-3	C26447 1-53, 1-55
C-1550 4-11, 4-13, 4-15, 4-17	C12836 5-3, 5-4	C18657 1-27, 2-12	C26506 3-3
C-2007 5-2	C12849 5-3, 5-4	C18662 1-27, 1-31, 1-37, 1-39, 1-41, 1-43, 1-45, 1-58	C26525 3-30
C-2008 5-2	C13282 5-3, 5-4	C18756 8-3	C26697 1-35, 1-39
C-2017 5-2	C13763 5-3, 5-4	C18758 1-3, 1-5, 1-7, 1-9, 1-10	C26820 4-5
C-2023 5-2	C14411 4-3, 4-5, 4-7, 4-9, 4-11, 4-13, 4-15, 4-17, 4-19, 4-21, 4-23, 4-25, 4-27, 4-29, 4-31, 4-32, 4-35, 4-56, 4-57	C18761 1-3, 1-5, 1-7, 1-10	C26840 2-2, 2-3, 2-4, 2-5, 2-6, 2-7
C-2026 5-2		C18781 1-11, 1-13, 1-58	C26844 , 1-35, 1-39
C-2030 5-2		C18782 1-27, 1-31, 1-37, 1-39, 1-41, 1-43, 1-45, 1-58	C26846 5-2
C-2135 5-3, 5-4		C20449 5-2	C28505 4-23, 4-29, 4-35
C-2136 5-3, 5-4		C24562 2-8, 2-9, 2-10, 2-11, 2-13	C29194 1-53, 1-55
C-2154 5-3, 5-4		C24585 4-3, 4-5, 4-7, 4-9, 4-11, 4-13, 4-15, 4-17, 4-19, 4-21, 4-23, 4-25, 4-27, 4-29, 4-31, 4-32, 4-35	C29565 4-3, 4-5
C-2155 5-3, 5-4			C29960 4-5
C-2164 5-3, 5-4			C29961 4-5
C-2187 5-2			C31361 1-15, 1-17, 1-20, 1-21, 1-37, 1-39
C-2215 5-2, 5-3, 5-4			C31438 10-3
C-3258 2-8, 2-9, 2-10, 2-11, 2-13			C31498 10-3
C-3684 7-15			C32025 5-2
C-3917 8-7, 1-19, 1-20, 1-			C32515 10-3, 10-5

C32925 1-23
 C33727 8-8, 8-9
 C33957 3-3
 C33958 3-3
 C34441 5-3
 C34442 1-34, 1-57, 4-7, 4-9, 4-11, 4-13, 1-22, 4-5
 C34592 5-5, 5-6
 C34596 5-5, 5-6
 C34598 5-5, 5-6
 C34599 5-5, 5-6
 C36064 5-3
 C39027 5-4
 C39029 5-4
 C39030 1-57, 4-11, 4-13
 C39031 5-4
 C39432 1-3, 1-5, 1-7, 1-9, 1-10
 C39490 4-11, 1-57, 4-13, 4-15, 1-57, 4-13
 C39892 5-5, 5-6
 C39900 5-5, 5-6
 C39904 5-5, 5-6
 C39906 5-5, 5-6
 C39910 5-6
 C39913 5-5, 5-6
 C39916 5-5, 5-6
 C39919 5-6
 C42311 4-21, 4-23, 4-25, 4-27, 4-29, 4-31
 C42312 4-21, 4-23, 4-25, 4-27, 4-29, 4-31
 C42313 4-21, 4-23, 4-25, 4-27, 4-29, 4-31
 C42314 4-21, 4-23, 4-25, 4-27, 4-29, 4-31
 C42912 9-8, 8-8
 C45675 5-5
 C47594 1-57, 4-15, 4-18, 5-5
 C50179 5-5
 C51033 3-9, 3-11, 5-8
 C51153 , 1-25, 1-24, 4-5, 8-9
 C53250 , 4-17, 5-7, 1-57
 C53255 1-57, 4-17, 4-18
 C53260 4-17
 C53847 5-12
 C53848 5-12
 C53849 , 4-5, 4-7, 4-9, 4-11, 4-13, 4-15, 4-17, 5-12
 C55803 4-17, 5-7
 C60599 4-17
 C64546 3-13, 5-8
 C68272 3-15, 5-8
 C71900 , 5-8, 3-15
 C72090 3-15
 C72720 3-15, 5-8

D
 D-4825 1-20, 1-24
 D-4837 2-12
 D-4838 4-3, 4-5, 4-7, 4-9, 4-21, 4-23, 4-25, 4-27, 4-29, 4-31
 D-4931 1-19, 1-21, 8-5
 D-4932 8-8, 8-9
 D-4947 2-12
 D-4951 4-3, 4-5, 4-7, 4-9, 4-11, 4-13, 4-15, 4-17, 4-35, 4-37, 4-41, 4-43, 4-47, 4-49, 4-51, 4-55, 4-56, 4-57, 4-53, 4-39, 4-45
 D-5054 4-19
 D-5238 2-12
 D-5239 2-2, 2-3, 2-4, 2-5, 2-6, 2-7, 2-8, 2-10
 D-5243 3-26, 3-27, 3-28, 3-29
 D-5244 1-3, 4-18, 1-22, 1-33, 1-34, 1-47, 1-49, 1-51, 1-53, 1-55, 1-57, 1-24
 D-5249 7-35
 D-5256 8-8, 8-9
 D-5260 3-24, 3-25
 D-5261 3-26, 3-27, 3-28, 3-29
 D-5272 3-5, 3-7
 D-5273 , 3-9, 3-11, 1-35, 1-9, 1-25, 1-39, 8-8, 8-9, 1-24
 D-5274 1-13, 3-7, 3-9, 3-11, 2-13
 D-5275 3-13, 3-15
 D-5277 6-3, 6-5, 6-7, 6-9, 6-11, 6-13, 6-15, 6-17, 6-19, 6-21, 6-23, 6-25, 7-2, 7-3, 7-5, 7-7, 7-9, 7-11, 7-13, 7-15, 7-17, 7-19, 7-21, 7-25, 7-29, 7-31, 7-33, 7-38, 7-39, 7-40
 D-5278 , 3-13, 7-39, 7-40
 D-5279 1-20, 1-21, 6-3, 6-5, 6-7, 7-11, 6-11, 6-13, 6-15, 6-17, 6-19, 6-21, 6-23, 6-25, 7-2, 7-3, 7-5, 7-7, 7-9, 7-13, 7-15, 7-17, 7-19, 7-21, 7-25, 7-29, 7-31, 7-33, 4-61, 4-63, 7-23
 D-5280 10-3, 10-5
 D-5402 2-12
 D-5489 7-35, 8-3, 8-8
 D-5498 2-12, 1-33, 1-47, 1-49, 1-53, 1-51, 1-55
 D-5519 1-3, 1-5, 1-7, 1-9, 1-10
 D-5558 1-33, 1-45, 1-47, 1-

49, 1-51, 1-53, 1-55
 D-5579 6-3, 6-5, 6-7, 6-9, 6-11, 6-13, 6-15, 6-17, 6-19, 6-21, 6-23, 6-25, 7-5, 7-7, 7-9, 7-11, 7-13, 7-15, 7-17, 7-19, 7-21, 7-23, 7-25, 7-29, 7-31, 7-33
 D12714 4-3, 4-7, 4-11, 4-15, 4-21, 4-25, 4-5, 6-5, 6-7, 4-9, 4-13, 4-17, 4-23, 4-32, 7-7, 7-9, 7-13, 7-15, 7-19, 7-21, 7-31, 7-33
 D12942 , 1-33
 D14565 7-23, 7-25
 D15435 4-5
 D17585 4-11, 4-13
 D17845 4-11, 4-13
F
 F-1713 1-24
 F-1767 3-15
 F-3009 2-6
 F-3056 2-2, 2-4, 2-8, 2-10
 F-3405 1-3, 2-5, 2-7, 1-10, 2-2, 2-4, 1-5, 1-7, 2-8, 1-9, 2-9, 2-10, 2-11
 F-3645 1-3, 1-33, 1-47, 1-49, 1-51, 1-53, 1-55
 F-3867 4-41, 4-47, 4-49, 4-51, 4-55, 9-7, 9-8, 4-53
 F-4490 3-5, 8-3
 F-4565 4-7, 4-11, 4-21, 4-23, 4-25, 4-27, 4-29, 4-31, 4-35, 4-37, 4-39, 4-41, 4-43, 4-45, 4-47, 4-49, 4-51, 4-53, 4-55
 F10384 4-5, 4-17, 4-21, 4-23, 4-25, 4-27, 4-29, 4-31, 4-37, 4-39, 4-41, 4-43, 4-45, 4-47, 4-49, 4-51, 4-53, 4-55, 4-56, 4-57, 8-8, 8-9, 8-10
 F10542 1-41, 1-43, 1-45
 F14658 4-11, 4-13
 F14659 4-23, 4-29
 F24559 4-5, 4-21, 4-23, 4-25, 4-27, 4-29, 4-31
H
 H-4408 4-27, 4-29, 4-31
 H-4410 4-25, 4-27, 4-29, 4-31
 H-4696 4-56
 H18266 4-15, 4-17, 4-49, 4-53, 4-55
 H18267 4-3, 4-5, 4-11, 4-13, 4-15, 4-17, 4-41, 4-

47, 4-49, 4-51, 4-53, 4-55
 H18268 1-24, 1-25
 H18269 , 9-7, 9-8, 4-17
 H18746 4-5, 4-21, 4-23, 4-25, 4-27, 4-29, 4-31, 4-55, 4-56, 4-57, 8-8, 8-9, 8-10
 H27972 1-37, 1-39
J
 J11333 8-9
 J12181 1-39, 8-5
 J12281 1-3, 1-7, 1-10
 J12344 1-13, 1-14, 1-19
K
 K-3830 1-20, 1-21, 6-3, 6-5, 6-7, 6-9, 6-11, 6-13, 6-15, 6-17, 6-19, 6-21, 6-23, 6-25, 7-5, 7-9, 7-11, 7-13, 7-15, 7-17, 7-19, 7-29, 7-31, 7-33
 K-5478 1-13
 K-5685 4-21, 4-23, 4-37, 4-39, 4-41, 4-43, 4-45, 4-47, 4-49, 4-51, 4-53, 4-55
 K-5806 4-3, 4-5, 4-7, 4-9, 4-11, 4-13, 4-15, 4-17, 4-21, 4-23, 4-25, 4-27, 4-29, 4-31, 4-32, 4-56, 4-57
 K50834 4-23, 4-29, 4-35
 K62977 4-23, 4-29, 4-31, 4-32, 4-58, 4-59, 4-61, 4-63
 K62978 4-23, 4-29
M
 M-3388 4-7, 4-11, 4-15, 1-33, 1-47, 4-37, 4-43, 1-49, 4-5, 4-9, 4-13, 3-15, 4-17, 3-18, 3-19, 4-39, 4-41, 4-45, 4-47, 4-49, 4-51, 1-51, 4-53, 1-53, 4-55, 1-55
N
 N11470 3-24, 3-25, 3-26, 3-27, 3-28, 3-29, 7-23, 7-25, 7-39, 7-40
 N11750 6-3, 6-9, 6-15, 6-21, 7-5, 7-11, 7-17, 7-29
 N11905 6-3, 6-5, 6-7, 6-9, 6-11, 6-13, 6-15, 6-17, 6-19, 6-21, 6-23, 6-25, 7-5, 7-7, 7-9, 7-11, 7-13, 7-15, 7-17, 7-19, 7-21, 7-23, 7-25, 7-29, 7-31, 7-33, 7-38
 N13962 1-34, 1-57, 2-2, 2-

4, 2-5, 2-6, 2-7, 2-8, 4-18, 1-22, 2-10	11, 4-13, 4-15, 4-17	17, 7-19, 7-21, 7-23, 7-25, 7-29, 7-31, 7-33	7, 7-9, 7-11, 7-13, 7-15, 7-17, 7-19, 7-21, 7-29, 7-31, 7-33
N14009 3-16, 3-17, 3-18, 3-19	N16226 8-3	N19575 6-9, 6-21	N31190 6-3, 6-5, 6-7, 6-9, 6-11, 6-13, 6-15, 6-17, 6-19, 6-21, 6-23, 6-25, 7-5, 7-7, 7-9, 7-11, 7-13, 7-15, 7-17, 7-19, 7-21, 7-29, 7-31, 7-33
N14011 3-16, 3-17, 3-18, 3-19	N16257 4-3, 4-5, 4-7, 4-9, 4-11, 4-13, 4-15, 4-17	N19578 4-39, 4-45, 4-51, 4-53	N31908 4-7, 4-9, 4-11, 4-13, 4-15, 4-17
N15096 6-3, 6-5, 6-7, 6-9, 6-11, 6-13, 6-17, 7-5, 7-7, 7-9, 7-11, 7-13, 7-15	N16504 6-15, 6-19, 6-21, 6-23, 6-25, 7-17, 7-19, 7-21, 7-25, 7-29, 7-31, 7-33	N19586 2-2, 2-3, 2-4, 2-5, 2-6, 2-7	N32001 10-3, 10-5
N15097 4-37, 4-43, 7-11, 4-23, 4-27, 4-39, 4-41, 1-41, 1-43, 1-45, 4-47, 4-49, 4-51, 1-51, 4-53, 4-55, 1-55, 7-5, 7-7, 7-9, 7-13, 7-15, 7-17, 7-19, 7-21, 7-23, 7-25, 7-29, 7-31, 7-33, 4-45, 8-3	N16507 6-15, 6-17, 6-19, 6-21, 6-23, 6-25, 7-17, 7-19, 7-21, 7-25, 7-29, 7-31, 7-33	N19717 6-3, 6-5, 6-7, 6-15, 6-17, 6-19, 7-5, 7-7, 7-9, 7-17, 7-19, 7-21	N32101 8-8, 8-9
N15098 1-20, 1-21, 4-15, 4-25, 6-5, 6-7, 7-11, 6-11, 6-13, 6-15, 6-17, 6-19, 6-23, 4-27, 4-29, 7-35, 7-5, 7-7, 7-9, 7-13, 7-15, 7-17, 4-17, 7-19, 7-21, 7-25, 7-29, 7-31, 4-31, 4-32, 7-33, 7-23	N16564 4-58	N19723 4-32	N32102 8-8, 8-9
N15102 6-3, 6-5, 6-7, 6-9, 6-11, 6-13, 6-15, 6-17, 6-19, 6-21, 6-23, 6-25, 7-5, 7-7, 7-9, 7-11, 7-13, 7-15, 7-17, 7-19, 7-21, 7-29, 7-31, 7-33	N16608 4-56	N19727 2-2, 2-3, 2-4, 2-5, 2-6, 2-7	N32457 8-8, 8-9, 8-10
N15105 6-3, 7-5, 7-17, 7-23, 7-29	N16610 1-24	N19769 7-35	N32481 8-8, 8-9
N15107 6-3, 6-5, 6-7, 6-9, 6-11, 6-13, 6-15, 6-17, 6-19, 6-21, 6-23, 6-25, 7-5, 7-7, 7-9, 7-11, 7-13, 7-15, 7-17, 7-19, 7-21, 7-29, 7-31, 7-33	N16689 6-15, 6-17, 6-19, 6-21, 6-23, 6-25, 7-17, 7-19, 7-21, 7-25, 7-29, 7-31, 7-33	N19770 7-35	N32482 8-8, 8-9, 8-10
N15135 6-3, 6-5, 6-7, 6-9, 6-11, 6-13, 6-15, 6-17, 6-19, 6-21, 6-23, 6-25, 7-5, 7-7, 7-9, 7-11, 7-13, 7-15, 7-17, 7-19, 7-21, 7-29, 7-31, 7-33	N19155 4-5	N21055 7-35	N32483 8-8, 8-9, 8-10
N15135 6-3, 6-5, 6-7, 6-9, 6-11, 6-13, 6-15, 6-17, 6-19, 6-21, 6-23, 6-25, 7-5, 7-7, 7-9, 7-11, 7-13, 7-15, 7-17, 7-19, 7-21, 7-29, 7-31, 7-33	N19164 2-12	N21060 7-35	N32498 6-11, 6-13, 6-23, 6-25
N15135 6-3, 6-5, 6-7, 6-9, 6-11, 6-13, 6-15, 6-17, 6-19, 6-21, 6-23, 6-25, 7-5, 7-7, 7-9, 7-11, 7-13, 7-15, 7-17, 7-19, 7-21, 7-29, 7-31, 7-33	N19165 2-12	N21061 7-35	N33342 1-31, 1-37, 1-45, 8-5, 1-39
N15135 6-3, 6-5, 6-7, 6-9, 6-11, 6-13, 6-15, 6-17, 6-19, 6-21, 6-23, 6-25, 7-5, 7-7, 7-9, 7-11, 7-13, 7-15, 7-17, 7-19, 7-21, 7-29, 7-31, 7-33	N19167 2-2, 2-3, 2-4, 2-5, 2-7	N21080 7-35	N33594 1-41, 1-43, 1-45
N15135 6-3, 6-5, 6-7, 6-9, 6-11, 6-13, 6-15, 6-17, 6-19, 6-21, 6-23, 6-25, 7-5, 7-7, 7-9, 7-11, 7-13, 7-15, 7-17, 7-19, 7-21, 7-29, 7-31, 7-33	N19168 2-2, 2-3, 2-4, 2-5, 2-7	N22778 1-20, 1-21, 6-9, 6-21, 7-9, 7-11, 7-15, 7-21, 7-29, 7-33	N33796 1-33, 1-47, 1-49, 1-51, 1-53, 1-55
N15135 6-3, 6-5, 6-7, 6-9, 6-11, 6-13, 6-15, 6-17, 6-19, 6-21, 6-23, 6-25, 7-5, 7-7, 7-9, 7-11, 7-13, 7-15, 7-17, 7-19, 7-21, 7-29, 7-31, 7-33	N19169 2-2, 2-3, 2-4, 2-5, 2-7	N24308 7-35	N33797 1-33, 1-47, 1-49, 1-51, 1-53, 1-55
N15135 6-3, 6-5, 6-7, 6-9, 6-11, 6-13, 6-15, 6-17, 6-19, 6-21, 6-23, 6-25, 7-5, 7-7, 7-9, 7-11, 7-13, 7-15, 7-17, 7-19, 7-21, 7-29, 7-31, 7-33	N19170 2-2, 2-3, 2-4, 2-5, 2-7	N24396 6-3, 6-5, 6-7, 6-9, 6-11, 6-13, 6-15, 6-17, 6-19, 6-21, 6-23, 6-25, 7-5, 7-7, 7-9, 7-11, 7-13, 7-15, 7-17, 7-19, 7-21, 7-23, 7-25, 7-29, 7-31, 7-33, 7-38	N33874 1-57
N15135 6-3, 6-5, 6-7, 6-9, 6-11, 6-13, 6-15, 6-17, 6-19, 6-21, 6-23, 6-25, 7-5, 7-7, 7-9, 7-11, 7-13, 7-15, 7-17, 7-19, 7-21, 7-29, 7-31, 7-33	N19171 2-2, 2-3, 2-4, 2-5, 2-7	N27609 4-58	N33998 2-13
N15135 6-3, 6-5, 6-7, 6-9, 6-11, 6-13, 6-15, 6-17, 6-19, 6-21, 6-23, 6-25, 7-5, 7-7, 7-9, 7-11, 7-13, 7-15, 7-17, 7-19, 7-21, 7-29, 7-31, 7-33	N19172 2-2, 2-3, 2-4, 2-5, 2-7	N27709 3-30	N34025 6-3, 6-15, 7-5, 7-35, 7-17
N15135 6-3, 6-5, 6-7, 6-9, 6-11, 6-13, 6-15, 6-17, 6-19, 6-21, 6-23, 6-25, 7-5, 7-7, 7-9, 7-11, 7-13, 7-15, 7-17, 7-19, 7-21, 7-29, 7-31, 7-33	N19173 2-2, 2-3, 2-4, 2-5, 2-7	N28988 1-34	N34319 4-3, 4-5, 4-7, 4-9, 4-11, 4-13, 4-15, 4-17, 4-19, 4-21, 4-23, 4-25, 4-27, 4-29, 4-31, 4-37, 4-39, 4-41, 4-43, 4-45, 4-47, 4-49, 4-51, 4-53, 4-55, 4-58
N15135 6-3, 6-5, 6-7, 6-9, 6-11, 6-13, 6-15, 6-17, 6-19, 6-21, 6-23, 6-25, 7-5, 7-7, 7-9, 7-11, 7-13, 7-15, 7-17, 7-19, 7-21, 7-29, 7-31, 7-33	N19173 2-2, 2-3, 2-4, 2-5, 2-7	N28994 1-57	N34423 8-8
N15135 6-3, 6-5, 6-7, 6-9, 6-11, 6-13, 6-15, 6-17, 6-19, 6-21, 6-23, 6-25, 7-5, 7-7, 7-9, 7-11, 7-13, 7-15, 7-17, 7-19, 7-21, 7-29, 7-31, 7-33	N19173 2-2, 2-3, 2-4, 2-5, 2-7	N28998 1-22, 1-57	N34443 4-3, 4-5, 4-7, 4-9, 4-11, 4-13, 4-15, 4-17, 4-21, 4-23, 4-25, 4-27, 4-29, 4-31, 4-32, 4-35, 4-56, 4-57
N15135 6-3, 6-5, 6-7, 6-9, 6-11, 6-13, 6-15, 6-17, 6-19, 6-21, 6-23, 6-25, 7-5, 7-7, 7-9, 7-11, 7-13, 7-15, 7-17, 7-19, 7-21, 7-29, 7-31, 7-33	N19203 1-19, 1-20, 1-21	N29048 10-3, 10-5	N34475 1-20, 1-21
N15135 6-3, 6-5, 6-7, 6-9, 6-11, 6-13, 6-15, 6-17, 6-19, 6-21, 6-23, 6-25, 7-5, 7-7, 7-9, 7-11, 7-13, 7-15, 7-17, 7-19, 7-21, 7-29, 7-31, 7-33	N19307 8-3	N29358 4-5, 8-8, 4-37, 4-43, 4-45, 4-51, 4-53, 8-9, 4-39	N34476 10-3, 10-5
N15135 6-3, 6-5, 6-7, 6-9, 6-11, 6-13, 6-15, 6-17, 6-19, 6-21, 6-23, 6-25, 7-5, 7-7, 7-9, 7-11, 7-13, 7-15, 7-17, 7-19, 7-21, 7-29, 7-31, 7-33	N19345 4-11, 4-13, 4-15, 4-17	N29384 4-58	N34477 10-3, 10-5
N15135 6-3, 6-5, 6-7, 6-9, 6-11, 6-13, 6-15, 6-17, 6-19, 6-21, 6-23, 6-25, 7-5, 7-7, 7-9, 7-11, 7-13, 7-15, 7-17, 7-19, 7-21, 7-29, 7-31, 7-33	N19406 6-3, 6-5, 6-7, 6-9, 6-11, 6-13, 6-15, 6-17, 6-19, 6-21, 6-23, 6-25, 7-5, 7-7, 7-9, 7-11, 7-13, 7-15, 7-17, 7-19, 7-21, 7-29, 7-31, 7-33	N29385 4-58	N34478 10-3, 10-5
N15135 6-3, 6-5, 6-7, 6-9, 6-11, 6-13, 6-15, 6-17, 6-19, 6-21, 6-23, 6-25, 7-5, 7-7, 7-9, 7-11, 7-13, 7-15, 7-17, 7-19, 7-21, 7-29, 7-31, 7-33	N19409 6-9, 6-21	N29486 4-58	N34488 4-21, 4-25, 4-27, 4-31, 4-35, 4-56, 4-57
N15135 6-3, 6-5, 6-7, 6-9, 6-11, 6-13, 6-15, 6-17, 6-19, 6-21, 6-23, 6-25, 7-5, 7-7, 7-9, 7-11, 7-13, 7-15, 7-17, 7-19, 7-21, 7-29, 7-31, 7-33	N19428 6-11, 6-13, 6-23, 6-25, 7-23, 7-25	N31012 3-13	N34498 4-56, 4-57
N15135 6-3, 6-5, 6-7, 6-9, 6-11, 6-13, 6-15, 6-17, 6-19, 6-21, 6-23, 6-25, 7-5, 7-7, 7-9, 7-11, 7-13, 7-15, 7-17, 7-19, 7-21, 7-29, 7-31, 7-33	N19448 6-3, 6-5, 6-7, 6-15, 6-17, 6-19, 7-5, 7-7, 7-9, 7-17, 7-19, 7-21	N31016 3-3	N34505 4-31, 4-35
N15135 6-3, 6-5, 6-7, 6-9, 6-11, 6-13, 6-15, 6-17, 6-19, 6-21, 6-23, 6-25, 7-5, 7-7, 7-9, 7-11, 7-13, 7-15, 7-17, 7-19, 7-21, 7-29, 7-31, 7-33	N19458 4-56	N31187 6-3, 6-5, 6-7, 6-9, 6-11, 6-13, 6-15, 6-17, 6-19, 6-21, 6-23, 6-25, 7-5, 7-7, 7-9, 7-11, 7-13, 7-15, 7-17, 7-19, 7-21, 7-29, 7-31, 7-33	N34576 4-35
N15135 6-3, 6-5, 6-7, 6-9, 6-11, 6-13, 6-15, 6-17, 6-19, 6-21, 6-23, 6-25, 7-5, 7-7, 7-9, 7-11, 7-13, 7-15, 7-17, 7-19, 7-21, 7-29, 7-31, 7-33	N19484 2-2, 2-3, 2-4, 2-5, 2-6, 2-7, 2-8, 2-10	N31189 6-3, 6-5, 6-7, 6-9, 6-11, 6-13, 6-15, 6-17, 6-19, 6-21, 6-23, 6-25, 7-5, 7-7, 7-9, 7-11, 7-13, 7-15, 7-17, 7-19, 7-21, 7-29, 7-31, 7-33	N34577 4-35
N15135 6-3, 6-5, 6-7, 6-9, 6-11, 6-13, 6-15, 6-17, 6-19, 6-21, 6-23, 6-25, 7-5, 7-7, 7-9, 7-11, 7-13, 7-15, 7-17, 7-19, 7-21, 7-29, 7-31, 7-33	N19531 6-3, 6-5, 6-7, 6-9, 6-11, 6-13, 6-15, 6-17, 6-19, 6-21, 6-23, 6-25, 7-5, 7-7, 7-9, 7-11, 7-13, 7-15, 7-17, 7-19, 7-21, 7-29, 7-31, 7-33	N31189 6-3, 6-5, 6-7, 6-9, 6-11, 6-13, 6-15, 6-17, 6-19, 6-21, 6-23, 6-25, 7-5, 7-7, 7-9, 7-11, 7-13, 7-15, 7-17, 7-19, 7-21, 7-29, 7-31, 7-33	N34578 4-35
N15757 3-30	N16143 4-3, 4-5, 4-7, 4-9, 4-11, 4-13, 4-15, 4-17	N31189 6-3, 6-5, 6-7, 6-9, 6-11, 6-13, 6-15, 6-17, 6-19, 6-21, 6-23, 6-25, 7-5, 7-7, 7-9, 7-11, 7-13, 7-15, 7-17, 7-19, 7-21, 7-29, 7-31, 7-33	N34620 4-21, 4-25, 4-27, 4-56, 4-57
N16143 4-3, 4-5, 4-7, 4-9, 4-11, 4-13, 4-15, 4-17		N31189 6-3, 6-5, 6-7, 6-9, 6-11, 6-13, 6-15, 6-17, 6-19, 6-21, 6-23, 6-25, 7-5, 7-7, 7-9, 7-11, 7-13, 7-15, 7-17, 7-19, 7-21, 7-29, 7-31, 7-33	N34626 1-13

N34646 4-23, 4-29, 4-31, 4-35	21, 4-23, 4-25, 4-27, 4-29, 4-31, 4-32	N62355 1-24	N67798 4-61
N34714 1-20, 1-21	N43681 10-5	N62356 1-24	N68000 4-61
N36148 7-38	N44710 1-3, 1-5, 1-7, 1-9	N64056 7-23, 7-25	N68001 4-61, 4-63
N36489 4-56	N44955 4-35	N64060 7-23, 7-25	N68950 4-61
N37018 4-58	N45036 7-35	N64061 7-23, 7-25	N69148 8-3
N37020 4-58	N45037 7-35	N64062 7-23, 7-25	N69290 7-38
N37035 4-35	N45042 7-35	N64064 7-23, 7-25	N69295 7-38
N37036 4-35	N45644 4-59	N64065 7-23, 7-25	N69296 7-38
N37049 8-3	N45690 7-35	N64070 7-23, 7-25	N72180 4-59
N37512 1-19, 8-5	N45694 6-3, 6-9, 6-15, 6-21, 7-5, 7-11, 7-17, 7-29	N64071 7-23, 7-25	N72181 4-59
N37523 8-2	N45696 6-3, 6-15, 7-5, 7-17	N64074 7-23, 7-25	N74006 4-58
N37630 6-9, 6-21, 7-9, 7-11, 7-15, 7-21, 7-29, 7-33	N46098 4-58	N64075 7-23, 7-25	N74222 4-63
N37787 3-26, 3-27, 3-28, 3-29	N46139 10-3	N64081 7-23, 7-25	N74270 4-63
N37914 4-35	N47712 1-23	N64082 7-25	
N37915 4-35	N47903 4-31, 4-32	N64092 7-23, 7-25	P
N37920 6-7, 6-13, 7-9, 7-15, 7-21, 7-25, 7-33	N48297 7-9, 7-15, 7-21, 7-33	N64094 7-23, 7-25	P1C10120 1-37, 1-39
N39840 6-9, 6-21	N49111 4-5	N64095 7-23, 7-25	P7C616 7-15, 7-33
N39876 6-3, 6-5, 6-11, 6-15, 6-17, 6-23	N50088 4-35	N64096 7-23, 7-25	P61D20 1-3, 1-5, 1-7, 1-9, 1-10, 1-17, 1-20, 1-21, 1-27, 1-31, 1-37, 1-39, 1-41, 1-43, 1-45, 1-57
N39877 6-5, 6-7, 6-9, 6-11, 6-13, 6-17, 6-19, 6-21, 6-23, 6-25	N50099 4-35	N64099 7-23, 7-25	
N40544 6-3, 6-5, 6-7, 6-9, 6-11, 6-13, 6-15, 6-17, 6-19, 6-21, 6-23, 6-25, 7-5, 7-7, 7-9, 7-11, 7-13, 7-15, 7-17, 7-19, 7-21, 7-29, 7-31, 7-33	N51955 7-3	N64399 7-23, 7-25	
N40704 6-9, 6-21, 7-11, 7-29	N51960 7-3	N64583 5-11	
N40715 6-3, 6-9, 6-15, 6-21, 7-5, 7-11, 7-17, 7-29	N51962 7-11, 7-15, 7-29, 7-33	N64671 4-61	
N40735 7-2, 7-3	N51967 7-13, 7-15, 7-31, 7-33	N65131 7-23, 7-39, 7-40	
N40995 7-25	N51977 7-15, 7-33	N65140 4-59	
N42091 1-23	N51979 7-15, 7-33	N65141 4-59	
N42098 3-3	N51983 7-2	N65142 4-59	
N42213 7-2, 7-3, 7-39, 7-40	N53200 7-2	N65143 4-59	
N42244 7-25	N53203 7-5, 7-7, 7-9, 7-17, 7-19, 7-21, 7-23, 7-25	N65145 4-59	
N42257 7-25	N53207 7-2	N65146 4-59	
N42274 6-3, 6-5, 6-7, 6-9, 6-11, 6-13, 6-15, 6-17, 6-19, 6-21, 6-23, 6-25, 7-5, 7-7, 7-9, 7-11, 7-13, 7-15, 7-17, 7-19, 7-21, 7-29, 7-31, 7-33	N53209 7-3	N65147 4-59	
N42880 4-3, 4-5, 4-7, 4-9, 4-11, 4-13, 4-15, 4-17, 4-19, 4-21, 4-23, 4-25, 4-27, 4-29, 4-31, 4-32, 4-37, 4-39, 4-41, 4-43, 4-45, 4-47, 4-49, 4-51, 4-53, 4-55	N53215 7-2, 7-3, 7-39, 7-40	N65148 4-59	
N42881 4-3, 4-5, 4-7, 4-9, 4-11, 4-13, 4-15, 4-17, 4-21, 4-23, 4-25, 4-27, 4-29, 4-31, 4-32, 4-37, 4-39, 4-41, 4-43, 4-45, 4-47, 4-49, 4-51, 4-53, 4-55	N53935 7-5, 7-17	N65149 4-59	
	N55257 7-5, 7-17	N66140 7-38	
	N55806 4-35	N66141 7-38	
	N56370 8-3	N66175 7-39, 7-40	
	N56371 8-3	N66177 7-39	
	N58340 4-35	N66178 7-39	
	N58341 4-35	N66179 7-40	
	N58342 4-35	N66180 7-40	
	N58343 4-35	N66507 7-39	
	N58670 4-23, 4-29, 4-35	N66508 7-39	
	N58671 1-5, 1-9, 4-23, 4-29, 4-35	N66509 7-40	
	N58963 4-23, 4-29, 4-58	N66510 7-40	
	N59010 4-61, 8-10	N66517 7-39	
	N60323 8-10	N66518 7-39	
	N60330 7-35	N66519 7-40	
	N60331 7-35	N66520 7-40	
	N60332 7-35	N66557 7-39	
	N60885 1-24, 1-25	N66558 7-39	
	N60900 4-3	N66559 7-40	
	N62238 4-5	N66560 7-40	
	N62351 7-25	N66662 7-40	
		N67037 4-61	
		N67038 4-61, 4-63	
		N67045 4-61, 4-63	
		N67046 4-61, 4-63	
		N67051 4-61	
		N67052 4-61	
			R
			R480034 6-3, 6-5, 6-7, 6-9, 6-11, 6-13, 6-15, 6-17, 6-19, 6-21, 6-23, 6-25, 7-5, 7-7, 7-9, 7-11, 7-13, 7-15, 7-17, 7-19, 7-21, 7-23, 7-25, 7-29, 7-31, 7-33
			R480045 4-37, 4-39, 4-41, 4-43, 4-45, 4-47, 4-49, 4-51, 4-53, 4-55
			R480055 6-3, 6-5, 6-7, 6-9, 6-11, 6-13, 6-15, 6-17, 6-19, 6-21, 6-23, 6-25, 7-5, 7-7, 7-9, 7-11, 7-13, 7-15, 7-17, 7-19, 7-21, 7-23, 7-25, 7-29, 7-31, 7-33
			R480060 7-23, 7-25
			S
			S-531 1-23
			S-711 1-17, 1-29
			S-747 7-2, 7-3
			S-752 2-9, 2-12, 1-13, 3-16, 1-27, 1-31, 1-41, 1-43, 2-8, 1-11, 2-13, 3-17, 1-37, 1-39, 2-10, 2-11, 3-18, 3-19
			S-951 6-9, 6-21
			S-1175 1-25
			S-1191 1-17, 1-28, 1-29
			S-1197 3-17, 3-30, 1-5, 1-9
			S-1198 4-5
			S-1292 1-23
			S-1311 2-8, 2-9, 2-10, 2-11, 2-12, 2-13

S-1344 1-31, 1-39, 1-41, 1-43, 1-45, 8-5	S39543 1-22, 1-34	S42849 1-37, 1-39	S44325 10-5
S-1925 1-23	S39545 1-24	S42861 1-30, 1-35, 1-41, 1-43	S44336 1-43, 1-45, 1-47, 1-49, 1-51, 1-53, 1-55
S13317 4-11, 4-13, 4-15, 4-17	S39546 4-5, 4-37, 4-39, 4-41, 4-43, 4-45, 4-47, 4-49, 4-51, 4-53, 4-55	S42862 1-27, 1-30, 1-43, 1-45, 1-47, 1-49, 1-51, 1-53, 1-55	S44337 1-43, 1-45, 1-47, 1-49, 1-51, 1-53, 1-55
S13336 4-3, 4-7, 4-9, 4-21, 4-25, 4-27, 4-29, 4-5, 8-8, 8-9, 4-23, 4-31, 8-10	S39548 4-19	S42865 3-24, 3-25	S44348 1-43
S22073 4-5	S39549 4-19	S42900 1-15, 2-4, 2-5	S44350 4-58
S22406 4-3, 4-5, 4-7, 4-9, 4-11, 4-13, 4-37, 4-39, 4-43, 4-45, 4-49, 4-51, 4-53, 4-55, 8-8, 8-9	S39559 1-24, 1-25	S42905 1-20, 1-21, 8-5	S44352 9-8, 4-37, 4-41, 4-43, 4-47, 4-49, 4-55
S27987 3-16, 3-17, 3-21, 3-22, 3-23, 3-24, 3-25, 3-26, 3-27, 3-28, 3-29	S39565 1-13, 4-3, 4-5, 4-7, 4-9, 4-11, 4-13, 4-15, 4-17	S42914 1-30, 1-33	S44353 4-41, 4-43, 4-47, 4-49, 4-51, 4-55, 9-7, 4-45, 4-53
S29958 4-21, 4-23, 4-25, 4-27, 4-29, 4-31, 4-32	S39567 1-57	S42918 1-27, 1-31, 1-37, 1-39	S44355 4-21, 4-23, 4-25, 4-27, 4-29, 4-31
S29959 4-21, 4-23, 4-25, 4-27, 4-29, 4-31, 4-32	S39570 1-57	S42919 1-27, 1-31, 1-37, 1-39	S44361 1-29
S29960 4-3, 4-7, 4-9, 4-11, 4-13, 4-15, 4-17	S39665 1-3, 1-5, 1-7, 1-9, 1-10	S42921 2-13	S44367 1-37
S29961 4-3, 4-7, 4-9, 4-11, 4-13, 4-15, 4-17	S39666 1-3, 1-5, 1-7, 1-9, 1-10	S42927 1-41, 1-43	S44370 8-3
S29967 8-8, 4-15, 4-17, 4-21, 4-23, 4-25, 4-27, 4-29, 4-31, 4-37, 4-39, 4-41, 4-43, 4-47, 4-49, 4-51, 4-53, 4-55, 4-45	S39669 1-3, 1-5, 1-7, 1-9, 1-10	S42942 1-3	S44402 3-3
S31980 3-25	S39728 1-11, 1-13, 1-58	S42943 1-3	S44404 3-20
S32545 2-8, 2-9, 2-10, 2-11	S39743 6-5, 6-7, 6-9, 6-11, 6-13, 6-17, 6-19, 6-21, 6-23, 6-25	S42944 1-3	S44405 3-20
S32556 2-2, 2-3, 2-4, 2-5, 2-7	S39747 6-5, 6-7, 6-9, 6-11, 6-13, 6-17, 6-19, 6-21, 6-23, 6-25	S42952 3-5, 3-7, 3-9, 3-11	S44406 3-20
S33404 1-11, 1-13	S39752 6-5, 6-7, 6-9, 6-11, 6-13, 6-17, 6-19, 6-21, 6-23, 6-25	S42956 1-30	S44407 3-20
S33420 7-2, 7-3	S39843 6-3, 6-5, 6-11, 6-15, 6-17, 6-23	S42957 1-30	S44423 8-8
S34115 4-21, 4-23, 4-25, 4-27, 4-29, 4-31	S39844 6-3, 6-5, 6-11, 6-15, 6-17, 6-23	S42963 9-2, 9-3, 9-5, 9-7	S44426 8-8
S34182 4-18	S39885 6-3, 6-5, 6-11, 6-15, 6-17, 6-23	S42964 1-19, 1-20, 1-21	S44427 8-8
S34428 4-3, 4-5, 4-7, 4-9, 4-11, 4-13, 4-15, 4-17	S39991 2-3, 2-4, 2-5	S42965 3-26, 3-27	S44440 3-30
S34464 10-5	S42294 3-3, 3-5, 3-7, 3-30	S42967 4-37, 4-39, 4-41, 4-47, 4-49, 4-51, 4-53, 4-55	S44444 3-30
S34465 10-5	S42320 4-21, 4-23, 4-25, 4-27, 4-29, 4-31	S42969 9-8, 4-37, 4-39, 4-41, 4-43, 4-47, 4-49, 4-51, 4-53, 4-55, 9-5, 9-7, 9-8, 4-45	S44445 3-30
S34466 10-5	S42434 1-39, 1-45, 1-58	S42976 1-31, 1-37	S44449 8-2
S39336 6-11, 6-13, 6-23, 6-25	S42440 1-39, 1-45, 1-58	S42977 1-31, 1-37	S44463 6-3, 6-5, 6-7, 6-15, 6-17, 6-19
S39380 4-19	S42622 1-15	S42982 1-27, 1-31, 1-33, 1-41, 1-43, 1-45, 1-47	S44464 4-58
S39391 1-3, 1-5, 1-7, 1-9, 1-10	S42649 1-17, 1-20, 1-21	S42986 2-13	S44465 1-29
S39440 2-9, 2-11	S42659 3-3	S42987 1-37, 1-39	S44467 6-5, 6-7, 6-11, 6-13, 6-17, 6-19, 6-23, 6-25, 7-7, 7-9, 7-13, 7-15, 7-19, 7-21, 7-31, 7-33
S39443 1-35, 1-39	S42673 3-9	S42998 4-21, 4-23, 4-25, 4-27, 4-29, 4-31, 8-10	S44468 4-21, 4-23, 4-25, 4-27, 4-29, 4-35, 4-56, 4-57
S39503 4-7, 4-9, 4-11, 4-13, 4-15, 4-17	S42674 3-9, 3-11	S42999 4-58	S44489 1-13
S39504 4-55	S42675 3-9, 3-11	S43741 8-2	S44491 1-13
S39523 4-11, 4-13, 4-15, 4-17, 4-25, 4-27, 4-29, 4-31	S42703 1-28	S44300 3-20	S44493 1-13
S39537 4-31	S42707 1-30	S44301 3-20	S44495 1-13
S39539 4-9, 4-13, 4-27, 4-29, 4-31	S42714 1-17, 1-19	S44307 6-5, 6-7, 6-11, 6-13, 6-17, 6-19, 6-23, 6-25, 7-7, 7-9, 7-13, 7-15, 7-19, 7-21, 7-31, 7-33	S44496 1-10
	S42725 1-19, 1-22, 1-31, 1-35, 1-39	S44308 6-3, 6-5, 6-7, 6-9, 6-11, 6-13, 6-15, 6-17, 6-19, 6-21, 6-23, 6-25, 7-5, 7-7, 7-9, 7-11, 7-13, 7-15, 7-17, 7-19, 7-21, 7-29, 7-31, 7-33	S44715 1-3, 1-5, 1-7, 1-9, 1-10
	S42802 1-37, 1-39	S44309 1-11, 2-2, 2-3	S44716 1-3, 1-5, 1-7, 1-9, 1-10
	S42812 1-41	S44311 1-57	S44717 1-3, 1-5, 1-7, 1-9, 1-10
	S42813 1-45, 1-57	S44313 1-37, 1-39, 4-41, 4-47, 4-49, 4-51, 4-53, 4-55	S44900 3-20
	S42815 1-57	S44314 1-19, 1-41, 1-43	S44902 1-13
	S42822 1-41, 1-43, 1-45		S44922 1-22
	S42828 1-57		S44929 4-25, 4-27, 4-29, 4-31
			S44930 4-21, 4-23, 4-25, 4-27, 4-29, 4-31
			S44932 4-21, 4-23, 4-25, 4-

27,4-29,4-31	S45796 1-33,1-47,1-49,1-51,1-53,1-55	S47506 1-17	S48842 3-16,3-17,3-18,3-19
S44945 4-21,4-25,4-27,4-29,4-23	S45797 1-14	S47509 2-2,2-3,2-4,2-5	S48843 3-16,3-17,3-18,3-19
S44959 1-43	S45821 6-11,6-13,6-23,6-25	S47510 2-2,2-3,2-4,2-5	S48844 3-18,3-19
S44962 1-13	S45822 6-11,6-13,6-23,6-25	S47512 2-2,2-3,2-4,2-5	S48845 4-21,4-23,4-25,4-27,4-29,4-31
S44963 1-13	S45823 6-11,6-13,6-23,6-25	S47517 1-19	S48846 3-16,3-17,3-18,3-19
S44965 1-13,2-6	S45824 6-11,6-13,6-23,6-25	S47518 1-19,1-39,1-45,8-5	S48847 3-16,3-17,3-18,3-19
S44969 1-13	S45902 1-14,1-19	S47520 1-39,8-5	S48848 3-16,3-18,3-19
S44971 1-13	S45903 1-14,1-19	S47521 1-39,8-5	S48849 3-16,3-17,3-18,3-19
S44976 3-29	S45913 1-17	S47522 1-45	S48850 3-15,3-16,3-17,3-18,3-19
S44977 3-28	S45915 1-17	S47527 3-9	S48852 3-9
S44979 1-22	S45917 1-17	S47530 8-2	S48853 3-9
S44981 1-22,1-30,1-33,1-35,1-39,1-41,1-43,1-45	S45921 1-19	S47531 1-47,1-49	S48883 4-47
S44983 1-27,1-57	S45922 1-19	S47533 1-23	S49250 3-9
S44984 1-27,1-31,1-37,1-39,1-41,1-43,1-45	S45926 1-39	S47534 1-23	S49260 3-3,3-5,3-7
S44985 1-27	S45936 1-39,8-5	S47537 1-23	S49290 3-9
S44991 1-27,1-31	S45941 1-19	S47540 1-23	S49299 3-16
S44993 1-27	S45945 1-39,8-5	S47542 1-23	S49500 3-3,3-16
S45250 1-13,4-21,4-23	S46181 3-26,3-28,3-29	S47543 1-23	S49516 3-3
S45254 2-6	S46334 3-30	S47557 2-8,2-9,2-10,2-11,2-12,2-13	S49536 3-28
S45257 2-6	S46384 3-27	S47589 1-19,1-21,8-5	S49537 3-29
S45258 2-6	S46506 8-3	S47591 4-18	S49545 4-21,4-23,4-25,4-27,4-29,4-31,4-58
S45259 2-6	S46595 3-3	S47592 4-19	S49800 1-29
S45260 2-6	S46924 8-8	S47595 1-57,4-18	S49804 1-22,1-35
S45261 2-6	S47050 1-45	S47597 4-18,4-19	S49811 1-35,1-39
S45262 2-6	S47059 1-33,1-45,1-49	S47600 1-45,1-57	S49815 1-37
S45264 9-2	S47060 1-33,1-45,1-47,1-49,1-51,1-53,1-55	S47627 2-3,2-5	S49817 1-43
S45265 9-2	S47061 1-30,1-33	S47629 2-3,2-5	S49819 1-41
S45269 3-25	S47064 1-30,1-33	S47630 1-14	S49822 8-5
S45276 1-45,1-47,1-49,1-51,1-53,1-55	S47067 1-31	S47634 8-5	S49824 8-5
S45277 1-13	S47070 1-14,1-19	S47635 8-5	S49826 8-5
S45278 2-6	S47076 3-21,3-22,3-23,3-26,3-27,3-28,3-29	S47637 8-5	S49828 8-5
S45289 1-17	S47080 1-15,1-19,2-4,2-5	S47640 8-5	S49835 1-19,1-20,1-21
S45290 1-58	S47084 1-27,1-31,1-37,1-39,1-41,1-43,1-45	S47642 4-3,4-5,4-7,4-9,4-11,4-13,4-15,4-17,4-21,4-23,4-25,4-27,4-29	S49841 1-33,1-47,1-49,1-51
S45297 1-19	S47093 3-20	S47644 1-47,1-49,1-53	S49842 1-33
S45312 3-26,3-27,3-28,3-29	S47094 4-21,4-23,4-25,4-27,4-29,4-31	S47655 1-31,1-37,1-39,1-41,1-43,1-45	S49843 1-20
S45313 3-26,3-27,3-28,3-29	S47095 4-25,4-27,4-29,4-31	S47656 1-47,1-49,1-51	S49845 1-22
S45470 3-26,3-27	S47110 3-3,3-5,3-7,3-17,3-30	S47687 3-30	S49850 1-33,1-47,1-49,1-51,1-53,1-55
S45720 2-9,1-31,1-37,1-41,1-43,1-45,2-8,1-39	S47128 3-26,3-27,3-28,3-29	S47692 3-30	S49853 1-41
S45750 1-39	S47139 5-9	S47693 3-30	S49855 1-53,1-55
S45759 1-33,1-45,1-47,1-49,1-51,1-53,1-55	S47140 5-9	S47694 3-30	S49886 1-13
S45767 1-45,1-47,1-49,1-51,1-53,1-55	S47141 5-9	S47695 3-30	S50205 1-3,1-5,1-7
S45771 1-33,1-47,1-49,1-51,1-53,1-55	S47142 5-9	S47749 1-33,1-45,1-47,1-49,1-51,1-53,1-55,4-41,4-47,4-49,4-51,4-53,4-55	S50210 3-9
S45779 1-57	S47143 5-9	S47799 4-43,4-45,4-49,4-51,4-53,4-55	S50245 3-26,3-27,3-28,3-29
S45780 1-45,1-47,1-49,1-51,1-53,1-55	S47334 4-31	S47976 3-3,4-37,4-41,4-43,4-47,4-49,4-55	S50246 3-3,3-5,3-7,3-16,3-17,3-18,3-19
S45791 1-17	S47337 3-25	S47980 3-26,3-27,3-28,3-29	S50247 3-3,3-5,3-7,3-16,3-17,3-18,3-19
S45792 1-37,1-39	S47395 3-30	S48813 3-27	
S45794 1-45		S48814 3-21,3-22,3-23,3-27	

S50463 8-9	S55905 1-35	S64076 1-41, 1-43, 1-45, 1-51, 1-55	S69573 3-15
S50464 8-9	S55909 1-5, 1-9	S64080 1-41, 1-43, 1-45, 1-51, 1-55	S69574 3-15
S50470 1-41	S55910 1-9	S64119 3-13	S69598 3-15
S50761 3-16, 3-17	S55913 1-5, 1-15	S64172 3-13	S71902 3-13
S51004 3-9, 3-11	S55914 1-9, 1-17, 1-19	S64194 3-3, 3-5, 3-20	S71912 3-5
S51005 3-9	S55915 1-35	S64195 3-3, 3-5, 3-20	S71913 3-5
S51006 3-9, 3-11	S55920 1-35, 1-39	S64672 3-13	S72042 3-13, 3-13
S51009 1-27, 1-31, 1-37, 1-39	S55925 1-35, 1-39	S64673 3-5, 3-18	S72046 3-15, 5-8
S51010 1-14	S55935 1-5	S64698 3-5	S72060 3-15, 3-19
S51011 1-27, 1-31, 1-37, 1-39	S55945 1-39, 1-35	S64759 3-13	S72061 3-13, 3-15
S51013 1-13, 2-7	S56135 8-3	S64940 4-61	S72065 3-15, 3-19
S51014 1-13, 2-7	S56450 1-7	S65000 3-5	S72070 3-5, 4-37, 4-39, 4-41, 4-43, 4-45, 4-47, 4-49, 4-51, 4-53, 4-55
S51015 1-27, 1-31, 1-33, 1-41, 1-43, 1-45, 1-47, 1-49, 1-51, 1-53, 1-55	S56454 1-7	S65009 3-13, 3-15	S72075 3-20
S51020 1-15, 2-4, 2-5	S56455 1-7	S65037 3-13	S72185 3-21
S51022 1-19, 1-33, 1-41, 1-43	S56482 3-22	S65038 3-13	S72297 3-7
S51023 1-13	S56483 3-23	S65039 3-13	S72302 3-7
S51024 1-41	S56485 3-21	S65048 3-13	S72303 3-7
S51025 1-27, 1-31, 1-37, 1-39, 1-41, 1-43, 1-45, 2-13	S56550 3-16	S65061 3-5, 3-7	S72306 3-21
S51040 3-17	S56558 8-10	S65070 3-5	S72308 3-23
S51041 3-17	S56720 9-2, 9-3, 9-5, 9-7	S65074 3-21, 3-22, 3-23	S72309 3-22
S51156 8-8	S56724 9-2, 9-5, 9-7	S65121 3-3, 3-5	S72310 3-24, 3-25, 3-26, 3-27, 3-28, 3-29
S51160 3-17	S57774 1-24	S65122 3-3, 3-5	S72321 3-7, 3-21
S51179 1-58	S58157 4-32	S65123 3-3, 3-16	S72322 3-7, 3-21
S51330 3-3	S58158 4-32	S65821 3-5	S72323 3-7, 3-23
S51335 4-19	S58700 4-31, 5-10	S65851 3-5	S72324 3-7, 3-22
S51336 4-18, 4-19	S58730 3-11	S65852 3-5	S72325 3-7, 3-24
S51463 3-3	S58744 3-11	S66171 3-5, 3-7	S72399 2-8, 2-9, 2-10, 2-11, 2-13
S51464 3-3, 3-5, 3-7	S58746 3-11	S66243 4-39, 4-45, 4-51, 4-53	S72410 5-8
S51466 3-3, 3-5, 3-7	S58747 3-11	S66245 3-7	S73071 3-13, 3-15
S51469 3-28	S58748 3-11	S66251 3-13, 3-15	S73086 3-20
S51470 3-29	S59800 3-9, 3-11	S66337 3-5, 3-7	S73260 3-13
S51494 3-9, 3-11, 5-8	S59801 3-11	S66338 3-5, 3-7	S73284 3-15
S53145 1-53, 1-55	S59802 3-11	S66403 3-5, 3-7	S73680 3-13
S53264 1-15, 1-19, 2-4, 2-5	S59803 3-11	S67170 3-7	S73685 3-13
S53265 1-11, 2-2, 2-3	S59804 3-11	S67303 3-15	
S53277 3-9	S59806 3-11, 3-15	S67304 3-15	
S53925 1-33, 1-45, 1-51, 1-53, 1-55	S59807 3-11	S67305 3-15	
S54297 8-10	S59842 5-10	S67317 5-11	
S54298 8-10	S59843 5-10	S67318 5-11	
S54767 9-5	S59844 5-10	S67319 5-11	
S54768 9-7	S59846 5-10	S67320 5-11	
S55035 8-3	S59850 9-7	S67549 3-15	
S55040 8-3	S59855 9-5, 9-7	S67613 3-15	
S55299 8-7	S59865 9-5, 9-7	S67944 3-7	
S55309 1-5, 1-9	S59866 1-51	S68006 4-32, 4-61, 4-63, 5-11	
S55320 8-8	S62026 2-2, 2-4, 2-8, 2-10	S68007 5-11	
S55335 8-7	S62027 2-2, 2-4, 2-8, 2-10	S68008 5-11	
S55455 3-16	S62050 2-2, 2-4	S68516 4-32	
S55629 2-2, 2-4	S62055 2-8, 2-10	S68519 4-32	
S55639 2-2, 2-4	S62065 3-9, 3-11	S69115 3-5	
S55697 8-7	S62072 4-31	S69305 3-7	
S55900 1-5, 1-9	S62085 2-2	S69349 3-5	
	S62358 1-22, 1-25	S69360 3-15	
	S62360 1-22, 1-25	S69398 3-13, 3-15	
	S62722 1-5, 1-9		
	S62723 1-5, 1-9		
	S62986 3-13		
	S63946 2-8, 2-10		

T

T-5245 2-9, 1-19, 1-31, 1-33, 1-35, 1-39, 1-41, 1-43, 1-45, 1-47, 1-49, 1-51, 1-53, 1-55, 2-11, 1-22, 8-5
T-5268 1-41, 1-43, 1-45, 3-17, 8-5

W

W-63 1-3, 1-7, 1-10, 1-25, 8-9, 1-24
W-187 1-13, 1-33, 1-47, 4-3, 6-5, 6-7, 7-11, 6-11, 6-13, 6-17, 6-19, 7-35, 1-49, 1-51, 1-53, 1-55, 7-5, 7-7, 7-9, 7-13, 7-15, 7-17, 7-19, 7-21, 7-23, 7-25, 7-29, 7-31, 7-33, 4-61, 4-63

W-418 3-18, 3-19	W-513 4-5	17, 4-23, 4-27, 4-29, 4-31, 4-32, 4-41, 4-47, 4-49, 4-55, 7-5, 7-7, 7-9, 7-13, 7-15, 7-17, 7-19, 7-21, 7-29, 7-31, 7-33, 4-39, 4-45, 4-51, 4-53, 4-59, 8-8, 8-9, 7-23, 7-25, 7-38, 8-3	W-1475 2-8, 2-9, 2-10, 2-11, 2-13
W-469 3-30, 4-18, 6-3, 6-5, 6-7, 6-9, 6-11, 6-13, 6-15, 6-17, 6-19, 6-21, 6-23, 6-25, 7-5, 7-7, 7-9, 7-11, 7-13, 7-15, 7-17, 7-19, 7-21, 7-25, 7-29, 7-31, 7-33, 7-38, 7-40	W-514 4-7, 4-11, 1-13, 4-15, 3-30, 4-18, 7-11, 4-15, 4-17, 4-19, 4-21, 4-23, 4-25, 4-27, 7-35, 4-37, 1-41, 1-43, 4-43, 1-45, 1-51, 1-55, 4-5, 4-9, 4-13, 4-17, 4-23, 4-27, 4-29, 4-31, 4-41, 4-47, 4-49, 4-55, 7-5, 7-7, 7-9, 7-13, 7-15, 7-17, 7-19, 7-21, 7-29, 7-31, 4-32, 7-33, 4-39, 4-45, 4-51, 4-53, 8-8, 8-9, 7-23, 7-25, 7-38, 8-3	W-525 1-20, 4-21, 4-19, 4-25, 6-11, 4-23, 1-24, 4-27, 4-29, 4-31, 7-15, 7-33	W-1537 2-8, 2-9, 2-10, 2-11, 2-12, 2-13
W-475 4-21, 4-23, 4-25, 4-27, 4-29, 4-31, 4-32, 7-7, 7-9, 7-21, 7-38, 4-59, 8-3	W-516 1-20, 4-21, 4-19, 4-25, 6-11, 6-13, 6-23, 1-24, 4-27, 4-29, 4-23, 4-31, 7-15, 7-33	W-526 1-3, 2-12, 1-13, 1-17, 1-19, 1-20, 4-21, 1-21, 1-23, 7-25, 4-25, 1-27, 1-30, 1-31, 1-33, 1-41, 1-43, 1-45, 1-47, 1-58, 1-11, 1-49, 2-6, 1-7, 1-9, 1-22, 4-27, 1-35, 1-37, 1-39, 4-41, 1-51, 1-53, 1-55, 4-23, 4-29, 4-47, 4-49, 7-5, 7-7, 7-9, 7-11, 7-13, 7-15, 7-17, 7-19, 7-29, 7-31, 4-31, 4-51, 4-53, 4-55, 8-5, 7-21, 7-23, 7-33, 9-2, 8-3, 9-7	W-1538 2-8, 2-9, 2-10, 2-11, 2-13
W-476 3-11, 3-16, 3-17, 3-30, 1-5, 1-9, 3-9, 1-35, 1-39, 8-8, 8-9, 3-18, 3-19	W-517 1-3, 2-12, 1-13, 1-17, 1-19, 1-20, 4-21, 1-21, 1-23, 7-25, 4-25, 1-27, 1-30, 1-31, 1-33, 1-41, 1-43, 1-45, 1-47, 2-8, 1-49, 2-6, 1-7, 1-9, 1-22, 4-27, 1-35, 1-37, 1-39, 4-41, 1-51, 1-53, 1-55, 4-23, 4-29, 4-47, 4-49, 7-5, 7-7, 7-9, 7-11, 7-13, 7-15, 7-17, 7-21, 7-29, 7-31, 4-31, 4-51, 4-53, 4-55, 8-3, 8-5, 7-23, 7-33, 9-2, 9-5, 9-7	W-527 1-3, 1-7, 1-10, 1-13, 1-14, 1-15, 1-17, 1-19, 1-20, 1-21, 1-27, 1-28, 1-29, 1-31, 1-33, 7-35, 1-37, 1-39, 1-41, 1-43, 1-45, 1-47, 1-49, 1-53, 1-51, 1-24, 1-55, 9-2, 9-3, 8-5, 9-7	W-1552 7-38
W-477 3-21, 3-22, 3-23	W-518 1-3, 1-7, 1-10, 1-13, 1-14, 1-15, 1-17, 1-19, 1-20, 1-21, 1-27, 1-28, 1-29, 1-31, 1-33, 7-35, 1-37, 1-39, 1-41, 1-43, 1-45, 1-47, 1-49, 1-53, 1-51, 1-24, 1-55, 9-2, 9-3, 8-5, 9-7	W-529 3-16, 3-17, 3-18, 3-19	W-1553 1-13
W-479 3-16, 3-17, 3-18	W-520 1-13, 1-14, 1-17, 1-19, 8-3, 1-29	W-530 3-9, 3-11	W-1628 1-25, 1-33, 1-47, 1-49, 1-51, 1-53, 1-55
W-480 4-7, 4-5, 4-9, 4-11, 4-13, 3-15, 4-15, 4-17, 3-19, 4-37, 4-39, 4-41, 4-43, 4-45, 4-47, 4-49, 4-51, 4-53, 4-55	W-521 4-3, 4-7, 4-9, 7-11, 4-11, 4-13, 4-15, 4-18, 4-19, 4-21, 4-25, 4-27, 7-35, 4-41, 4-47, 4-49, 4-56, 4-58, 4-5, 4-17, 4-23, 4-29, 4-31, 4-35, 4-37, 4-43, 4-51, 4-53, 4-55, 4-59, 7-5, 7-7, 7-9, 7-13, 7-15, 7-17, 7-19, 7-21, 7-25, 7-29, 7-31, 7-33, 4-39, 4-45	W-538 4-3, 4-5, 4-7, 4-9, 4-11, 4-13, 4-15, 4-17, 4-32, 4-37, 4-39, 4-41, 4-43, 4-45, 4-47, 4-49, 4-51, 4-53, 4-55, 4-59	W-1663 1-23
W-484 10-3, 10-5	W-522 3-3, 3-15, 4-5	W-539 10-3, 10-5	W-3328 2-8, 2-9, 2-10, 2-11, 2-12, 2-13
W-485 4-21, 4-25, 4-23, 7-25, 4-27, 4-29, 7-23, 4-31	W-523 4-7, 4-11, 1-13, 4-15, 3-30, 4-18, 4-9, 7-11, 4-15, 4-17, 4-19, 4-21, 4-23, 4-25, 4-27, 7-35, 4-37, 1-41, 1-43, 4-43, 1-45, 1-51, 1-55, 4-5, 4-13, 4-17, 4-23, 4-27, 4-29, 4-31, 4-35, 4-37, 4-43, 4-51, 4-53, 4-55, 4-59, 7-5, 7-7, 7-9, 7-13, 7-15, 7-17, 7-19, 7-21, 7-25, 7-29, 7-31, 7-33, 4-39, 4-45	W-558 1-17, 1-20, 1-21, 1-27, 1-31, 1-37, 1-39, 1-41, 1-43, 1-45, 1-57	W-3687 7-33
W-486 3-3, 3-17		W-629 1-19, 1-20, 1-21, 7-25, 9-2, 9-7, 7-23	W-4181 1-22, 1-25, 1-34, 1-57, 2-2
W-487 3-3, 3-5, 3-7, 3-17		W-867 7-2, 7-3, 7-11, 7-13, 7-15, 7-17, 7-19, 7-23, 7-29, 7-31, 7-33	W-4187 3-16, 3-17
W-488 1-3, 1-5, 1-7, 1-9, 1-10			W21962 4-11, 4-13, 4-15, 4-17
W-489 1-3, 1-5, 1-7, 1-9, 1-10			W21963 4-25, 4-27, 4-29
W-490 1-3, 1-7, 1-9, 1-10, 3-30, 1-5			
W-493 2-9, 2-10, 2-11			
W-495 2-2, 2-3, 2-4, 2-5, 2-7, 2-8			
W-497 1-11, 1-13, 1-27, 1-31, 1-37, 1-41, 1-43, 1-45, 7-17, 1-39			
W-498 2-12, 7-25, 1-30, 1-33, 1-35, 1-41, 1-43, 1-45, 1-47, 1-49, 1-53, 1-51, 1-55, 2-6, 7-23			
W-499 1-5, 1-9, 1-27			
W-502 3-30			
W-503 7-23, 7-25			
W-506 1-22, 1-30, 1-33, 1-35, 1-39, 1-47, 1-49, 1-51, 1-53, 1-55			
W-509 1-13, 1-14, 1-15, 1-17, 1-19, 1-27, 1-31, 1-37, 1-39, 1-41, 1-43, 1-45, 8-5			
W-512 4-3, 4-7, 4-9, 7-11, 4-11, 4-13, 4-15, 4-18, 4-19, 4-21, 4-25, 4-27, 7-35, 4-41, 4-47, 4-49, 4-56, 4-58, 4-5, 4-17, 4-23, 4-29, 4-31, 4-35, 4-37, 4-43, 4-51, 4-53, 4-55, 4-59, 7-5, 7-7, 7-9, 7-13, 7-15, 7-17, 7-19, 7-21, 7-25, 7-29, 7-31, 7-33, 4-39, 4-45			

--	--	--	--



www.morrisequipment.ca

1891 Albert Street North,
Regina, Saskatchewan
S4R 8R7 Canada
Phone: 306-933-8585
Fax: 306-933-8626

It is the policy of Morris Equipment Ltd. to improve its products whenever it is possible to do so. Morris Equipment reserves the right to make changes or add improvements at any time without incurring any obligation to make such changes on machines sold previously.