



OPERATOR'S MANUAL

QUANTUM
Air Drill

Table of Contents

Section 1:	
Safety	1-1
Signal Words	1-2
General Operation	1-3
Tractor Operation	1-3
Chemicals.....	1-4
Transporting	1-5
Hydraulics.....	1-5
Maintenance.....	1-6
Storage	1-6
Safety Signs	1-7
Lighting and Marking.....	1-13
Section 2:	
Specifications	2-1
Specifications and Options.....	2-2
Transport Dimensions	2-3
Section 3:	
Checklist	3-1
Manuals.....	3-2
Checklist.....	3-3
Section 4:	
Introduction	4-1
Introduction.....	4-2
Active Hydraulic System	4-3
Section 5:	
Operation	5-1
Application.....	5-2
Tractor.....	5-2
Hitching	5-3
Hitching to Tractor	5-3
Unhitching from Tractor	5-4
JEM CC Pilot Display Wiring	5-5
9 Series Air Cart X35 Apollo - Lift and Pressure Control Wiring	5-6
10 Series Air Cart XD+ Apollo - Lift and Pressure Control Wiring.....	5-8
Hydraulic Flow Adjustment	5-10
Controller Options	5-11
JEM CC Pilot Display	5-11
Transport.....	5-12
Transport to Field Position	5-13
Field to Transport Position.....	5-14
Opener Hydraulic System	5-15
Basic function of the system	5-15
Lifting/Lowering	5-15
Pressure Setting.....	5-16
Operating Pressure Adjustment.....	5-17
Field Operation.....	5-19
Depth Adjustment.....	5-20
Work Switch.....	5-22
General Guidelines.....	5-23
Quick Tips.....	5-24
Shank Trip Force	5-24
Packing Force.....	5-24
Hydraulic System	5-24

Table of Contents

Lifting and Lowering the Openers	5-24
Setting the Seed Depth	5-25
Seeding Conditions	5-25
Straw Management	5-25
Air Drill Frame	5-26
Wing Lift Hydraulics	5-27
Opener Hydraulics	5-29
Section 6:	
Maintenance.....	6-1
General.....	6-2
Safety	6-2
Tighten Bolts	6-3
Tires	6-3
Lubrication.....	6-4
Opener Maintenance	6-5
Bushings Replacement.....	6-5
Cylinder Replacement.....	6-5
Opener Body Assembly.....	6-6
Opener Assembly.....	6-8
Shank Replacement.....	6-15
Bleeding Hydraulic System.....	6-16
Hydraulic System Trouble Shooting	6-17
Hydraulics.....	6-18
Wheel Bearings.....	6-19
Implement Hub.....	6-19
Opener Hub	6-20
Pack Control Hub	6-21
Packer Wheel Assemblies	6-22
Section 7:	
Storage.....	7-1
Preparing for Storage	7-2
Wing Lift Cylinder Shaft Protection	7-3
Removing From Storage.....	7-3
Section 8:	
Troubleshooting.....	8-1
Machine not operating straight.	8-2
Lack of penetration.....	8-2
Openers wearing unevenly.....	8-2
Wing lifting too slowly.....	8-2
Wings not lowering.	8-2
One wing will lift, other will not.	8-2
Oil accumulation.....	8-2
Openers drop quickly after transport lock valve is closed.....	8-2
Openers won't lift or lower.....	8-3
Openers won't lift.....	8-3
Opener pressure won't change.	8-3
Openers can not be fully pressurized.....	8-3
Openers not fully lifting to transport position.....	8-4
Excessive seed depth and soil throw.....	8-4
Shanks hang back and trip out during normal operation.....	8-4
Seed rows covered in loose soil after seeding.....	8-4
Packer wheels bounce and chatter excessively in field.	8-4

Section 1: Safety

Section Contents

Signal Words.....	1-2
General Operation	1-3
Tractor Operation	1-3
Chemicals.....	1-4
Transporting	1-5
Hydraulics	1-5
Maintenance	1-6
Storage	1-6
Safety Signs	1-7
Lighting and Marking	1-13

Safety

SAFETY-ALERT SYMBOL



Watch for this symbol. It identifies potential hazards to health or personal safety. It means:

**ATTENTION - BE ALERT.
Your Safety is involved.**

Familiarize yourself with the location of all decals. Read them carefully to understand the safe operation of your machine.

Signal Words

The words **DANGER**, **WARNING** or **CAUTION** are used with the safety alert symbol. Learn to recognize the safety alerts, and follow the recommended precautions and safe practices.

Three words are used in conjunction with the safety-alert symbol:



DANGER

Indicates an imminently hazardous situation that, if not avoided, will result in **DEATH OR SERIOUS INJURY**.



WARNING

Indicates a potentially hazardous situation that, if not avoided, could result in **DEATH OR SERIOUS INJURY**.



CAUTION

Indicates a potentially hazardous situation that, if not avoided, may result in **MINOR OR MODERATE INJURY**.

Replace any **DANGER**, **WARNING**, **CAUTION** or instructional decal that is not readable or is missing. The location and part number of these decals is identified later in this section of the manual.

The words **Important** and **Note** are not related to personal safety but are used to give additional information and tips for operating or servicing this equipment.

IMPORTANT: Identifies special instructions or procedures which, if not strictly observed could result in damage to, or destruction of the machine, process or its surroundings.

NOTE: Indicates points of particular interest for more efficient and convenient repair or operation.

General Operation

- **DO NOT RIDE!!** Do not allow riders on the implement when in motion.
- Do not allow extra riders in the tractor unless an instructor seat and seat belt are available.
- **Check behind** when backing up.
- **Reduce speed** when working in hilly terrain.
- Never allow anyone within the immediate area when operating machinery.
- **Stand clear** when raising or lowering wings.
- **Keep all shields in place**, replace them if removed for service work.

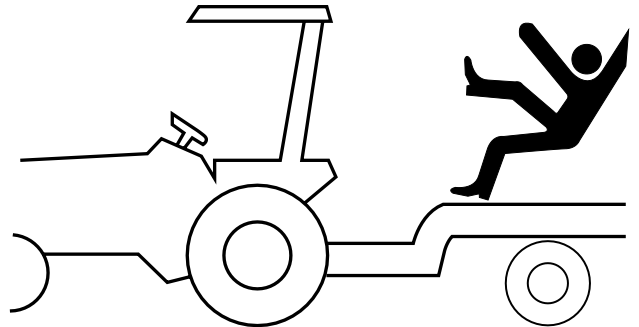

Tractor Operation

- Be aware of the correct tractor operating procedures, when working with implements.
- Review tractor operator's manual.
- Secure hitch pin with a retainer and lock drawbar in centre position.

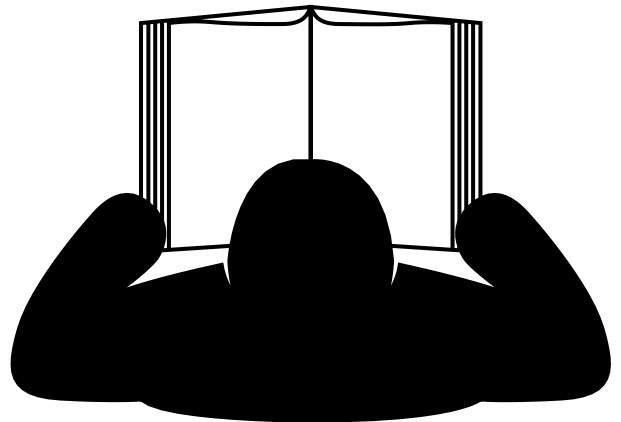

Safety

Chemicals

- **Use extreme care** when cleaning, filling or making adjustments.
- **Always read** granular chemical or treated seed manufacturer's warning labels carefully and remember them.
- Wear close fitting clothing and appropriate personal protective equipment for the job as specified by the chemical and/or seed manufacturer.
- **Always wear** safety goggles, breathing apparatus and gloves when handling with granular chemical or treated seed.
- **Do not feed** any treated seed to livestock. Treated seed is poisonous and may cause harm to persons or livestock.
- **Wash exposed skin immediately** - do not leave chemicals on your skin.
- **Properly store** chemicals in original containers with labels intact per the manufacturer's instructions.
- Always follow the manufacturer's operating instructions and warning labels when operating an ammonia tank with the equipment.
- **Do Not enter Air Cart tank unless another person is present and the tractor engine has been shut off.**



Danger

Failure to comply may result in death or serious injury.

Read Operator's Manual and decals on **Ammonia** tank before operating Air Cart. Become familiar with all warnings, instructions, and controls.

Always wear gloves and goggles when transferring or handling ammonia.

Always stay clear of hose and valve openings.

Always be sure pressure is relieved before disconnecting hoses or parts.

Always secure connecting parts and safety chains before towing ammonia trailer.

Always have ample water available in case of exposure to ammonia liquid or gases.

Transporting

- **Be aware** of the height, length and width of implement. Make turns carefully and be aware of obstacles and overhead electrical lines.
- Always travel at a safe speed. Do Not Exceed 20 mph (30 km/h).
- Use an agricultural tractor that is large enough with sufficient braking capacity so that the weight of the loaded equipment towed **does not exceed 1.5 times** the weight of the tractor.
- Use flashing amber warning lights, turn signals and SMV emblems when on public roads.
- Do not transport in poor visibility.
- The slow moving vehicle (SMV) emblem, speed identification symbol (SIS) and reflectors must be secured and be visible on the machine for transport.
- When towing equipment combinations, the maximum equipment combination ground speed shall be limited to the lowest specified ground speed of any of the towed machines.
- Avoid soft surfaces, the additional wing weight on the centre wheels could cause the machine to sink.
- Ensure safety chain is attached correctly to the towing vehicle and the hitch of the implement.
- Check that wings are firmly seated on transport wing stops, and wing lift valve and opener valve are in locked position.
- Be familiar with and adhere to local laws.

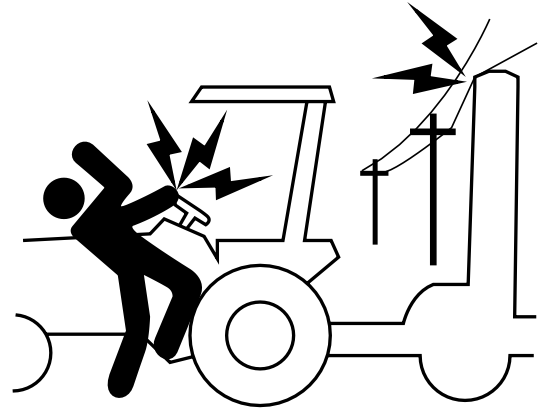

Hydraulics

- **Do not** search for high pressure hydraulic leaks without hand and face protection. A tiny, almost invisible leak can penetrate skin, thereby requiring immediate medical attention.
- Use cardboard or wood to detect leaks - never your hands.
- Double check that all is clear before operating hydraulics.
- **Never** remove hydraulic hoses or ends with machine elevated. Relieve hydraulic pressure before disconnecting hydraulic hoses or ends.
- Maintain proper hydraulic fluid levels.
- Keep all connectors clean for positive connections.
- Ensure all fittings and hoses are in good condition.
- Do not stand under wings.

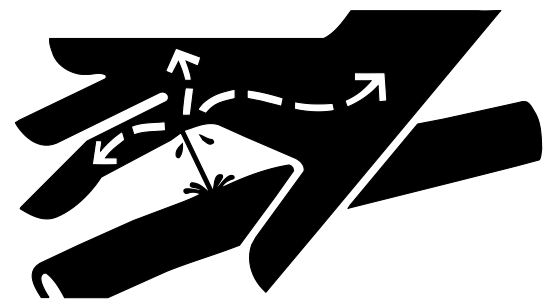

Safety

Maintenance

- **Shut tractor engine off** before making any adjustments or lubricating the machine.
- **Block** machine securely to prevent any movement during servicing.
- Wear close fitting clothing and appropriate personal protective equipment for the job.
- **Always wear** safety goggles, breathing apparatus and gloves when working on seeder filled with granular chemical or treated seed per the manufacture's instructions.
- Do not modify the machine.

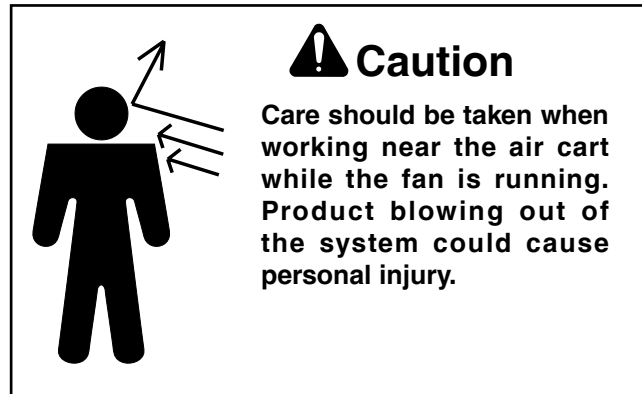

Storage

- Store implement away from areas of main activity.
- Level implement and block up securely to relieve pressure on jack.
- Do not allow children to play on or around stored implement.

Safety Signs

Danger: Crushing Hazard

To prevent death or serious injury:

- Wings may fall rapidly causing bodily injury.
- Stand Clear - Of Wings when being raised, lowered or in elevated state.
- Over Head Hazard - Gauge wheels swing down. Keep clear of area after wings are raised.
- Always install all Lockup devices provided when wings are in elevated position.
- Ensure Cylinders are completely filled with hydraulic fluid to avoid unexpected movement.

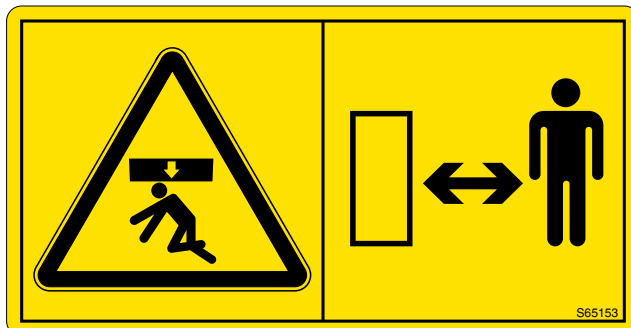

Warning: Crushing Hazard

To prevent serious injury or death:

- Stand Clear - openers move rapidly under hydraulic pressure.
- Stand Clear - Openers drop with full down force when powering up or rebooting controller with hydraulics engaged.
- Before servicing hydraulics - Lower openers to ground and relieve pressure from hydraulic system.
- Ensure Opener Hydraulic System is disabled before working underneath machine.
 - Shut tractor off and remove key before servicing or adjusting depth.
 - Place “Openers” valve in locked position before adjusting depth or transporting.

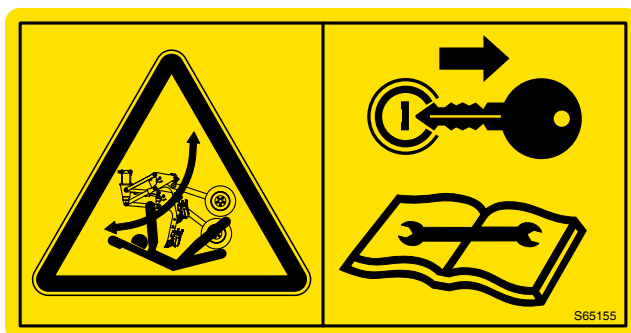

Warning: HIGH-PRESSURE FLUID HAZARD

To prevent serious injury or death:

- Relieve pressure on hydraulic system before servicing or disconnecting hoses.
- Wear proper hand and eye protection when searching for leaks. Use wood or cardboard instead of hands.
- Keep all components in good repair.
- Refer to tractor and implement Operator's Manuals service specifications.
- Use lock-out tags/procedures as required to prevent unanticipated machine operation.

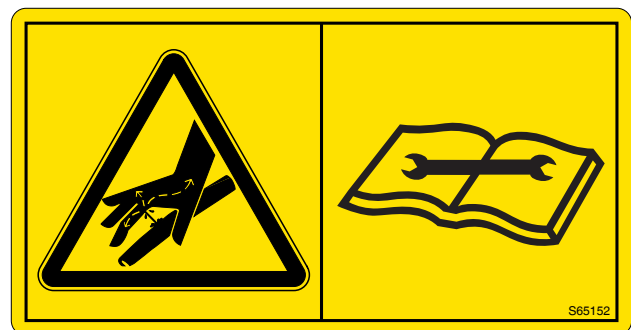

Familiarize yourself with the location of all decals. Read them carefully to understand the safe operation of your machine.

Safety

Safety Signs - Continued

Warning: Loss of control hazard!

To prevent serious injury or death:

- Drive within the limits of road conditions and machine loading.
- Never exceed 30 km/h (20 mph) when towing the machine.

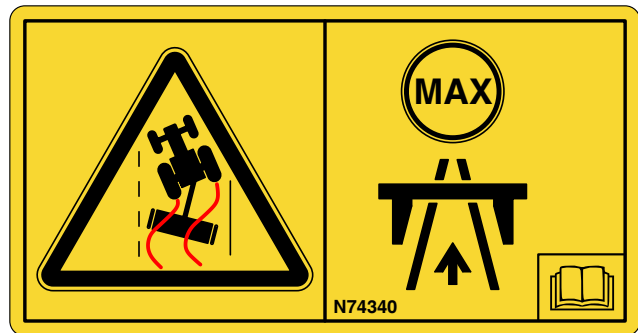

Warning: No Riders

To prevent serious injury or death:

- Keep off while machine is moving or mechanism is running.

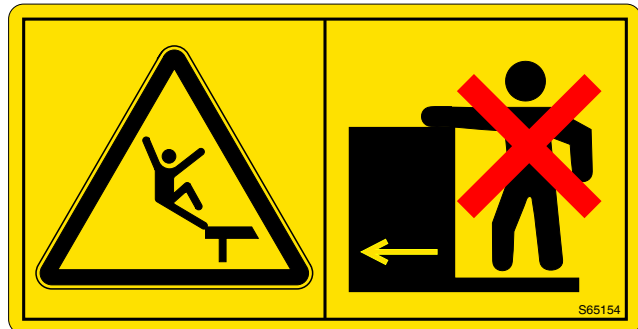

Warning: Before Servicing

To prevent serious injury or death:

- Stop the tractor and remove key, read the service specifications at the back of this manual.
- Use lock-out tags/procedures as required to prevent unanticipated machine operation.
- Do not operate with guard removed.
- Failure to comply could result in death or serious injury

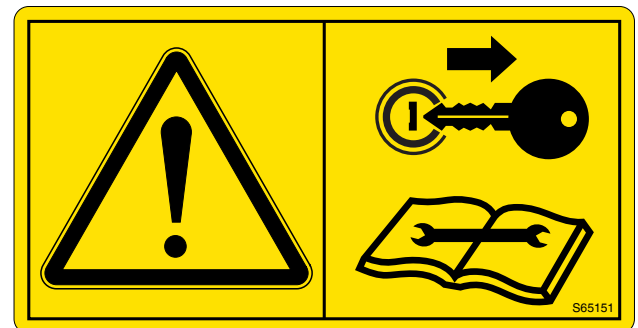

Caution: Avoid injury!

Read and follow the instructions in this manual.
Failure to comply could result in minor or moderate injury



Familiarize yourself with the location of all decals. Read them carefully to understand the safe operation of your machine.

Safety Signs - Continued

Opener Hydraulic Lock

 System is Locked-Out from Tractor Hydraulics

 System is Open to Tractor Hydraulics

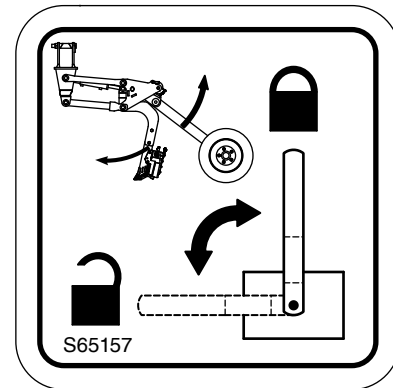

Wing Lift Hydraulic Lock

 System is Locked-Out from Tractor Hydraulics

 System is Open to Tractor Hydraulics

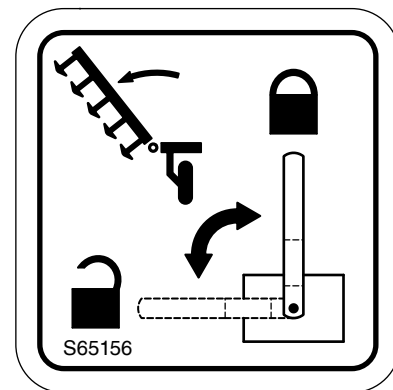

Safety

Safety Signs - Continued

Decal Locations - 40 and 50 Models

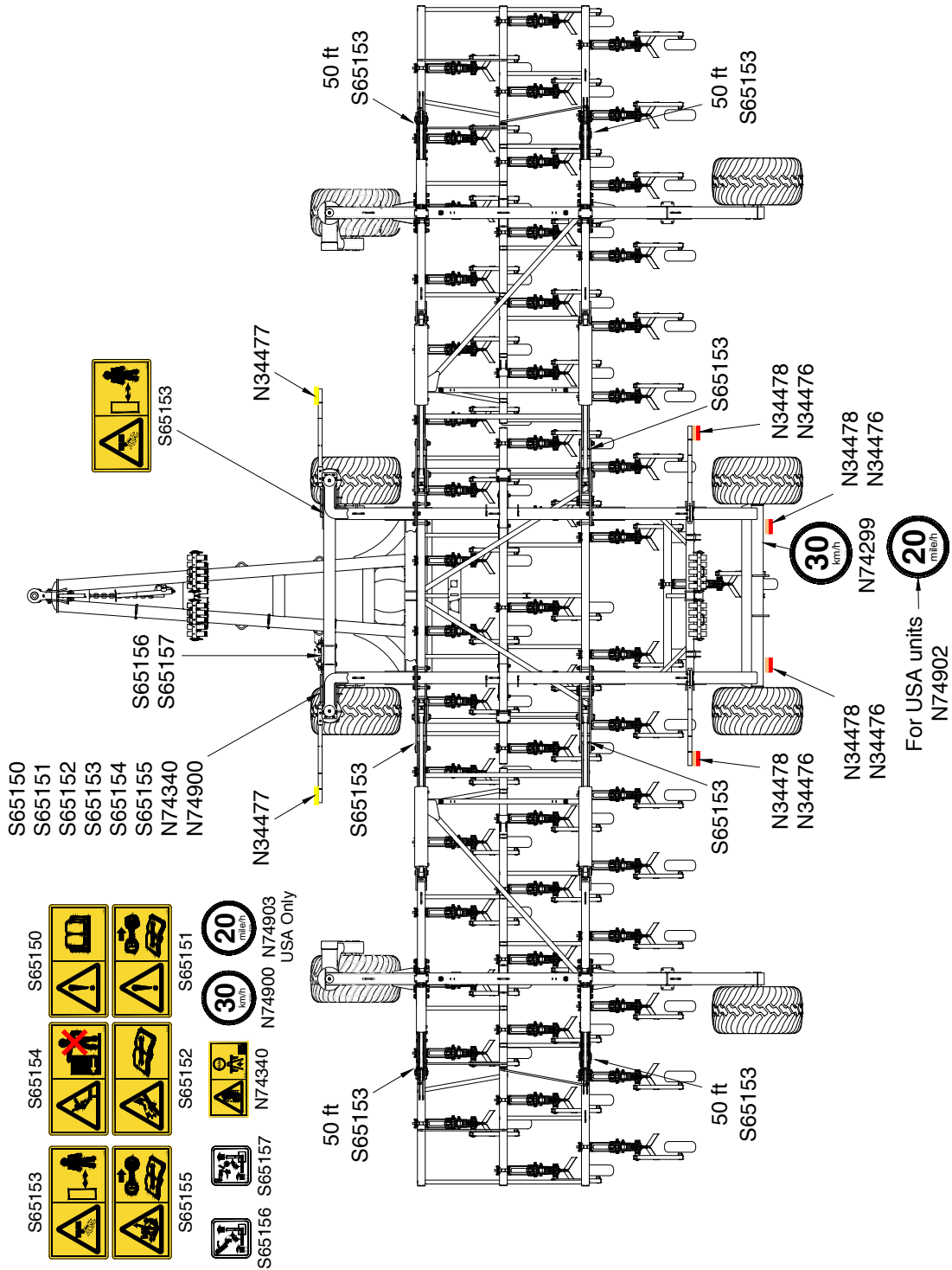

Safety Signs - Continued

Decal Locations - 60 and 70 Models

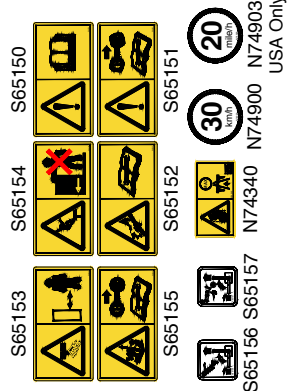
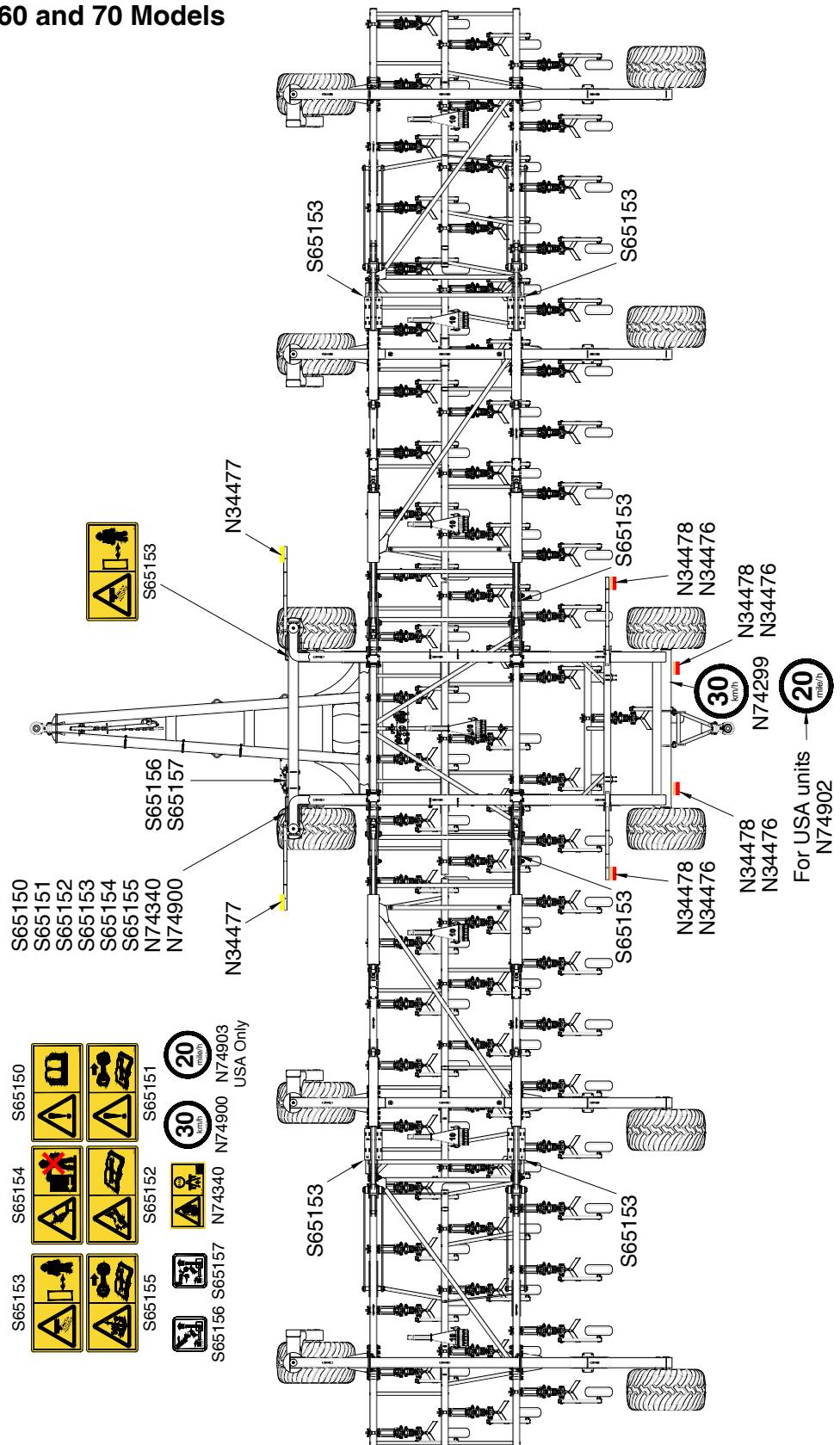

Safety

Safety Signs - Continued

Decal Locations - 80 Models

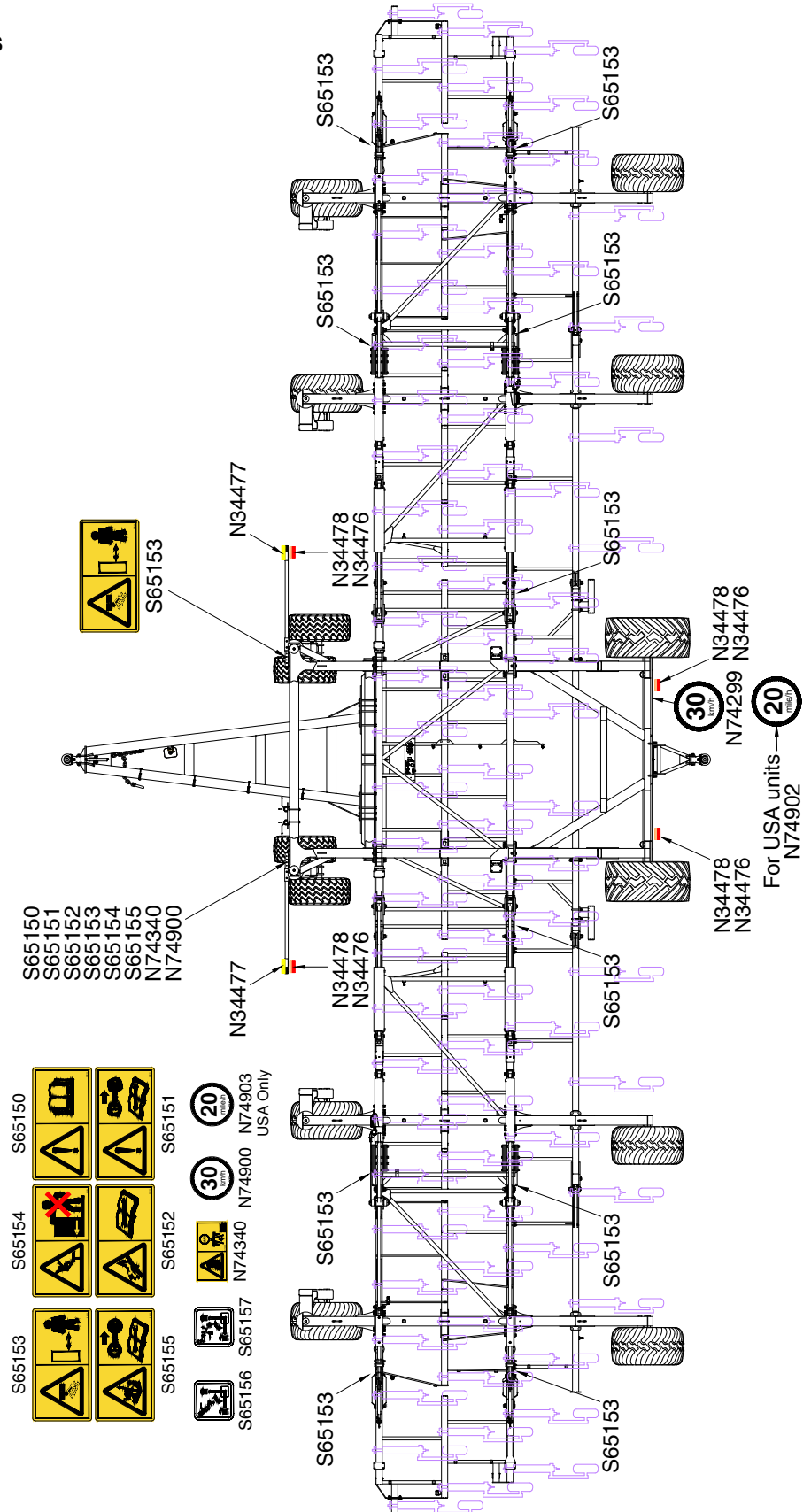

Lighting and Marking

MORRIS recommends the use of correct lighting and marking to meet the ASAE standard for roadway travel. Be familiar with and adhere to local laws.

Amber warning and red tail lights secured on the machine promote correct transportation of this implement.

Note: Always replace missing or damaged lights and/or connectors.

Amber warning and red tail lights must be mounted to the rear of the implement and be visible from front and rear. The lights must be within 16 inches (41 cm) of the extremities of the machine and at least 24 inches (60 cm) but not over 10 feet (3 m) above ground level.

Note: Always replace missing or damage front, side, rear reflectors, SMV emblem and SIS decal.

Rear View

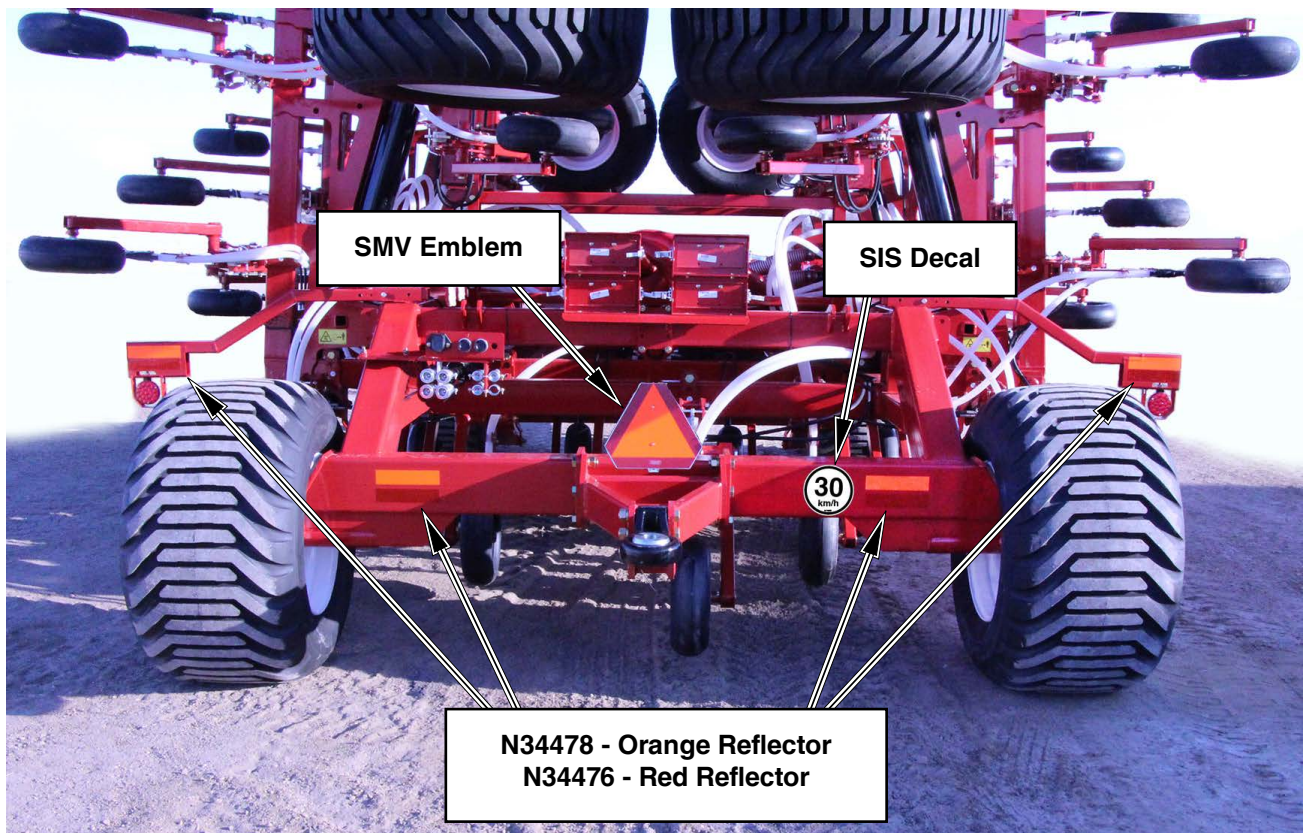

Safety

Lighting and Marking - Continued

Front View

Over Head Hazard



Gauge wheels swing down.
Keep clear of area after
wings are raised.

The image shows a yellow rectangular warning sign with a black border. On the left is a triangular warning symbol depicting a person being struck by a falling object. On the right is a pictogram of a person standing next to a vertical rectangle, with a double-headed arrow between them, indicating a clearance or swing-down hazard.

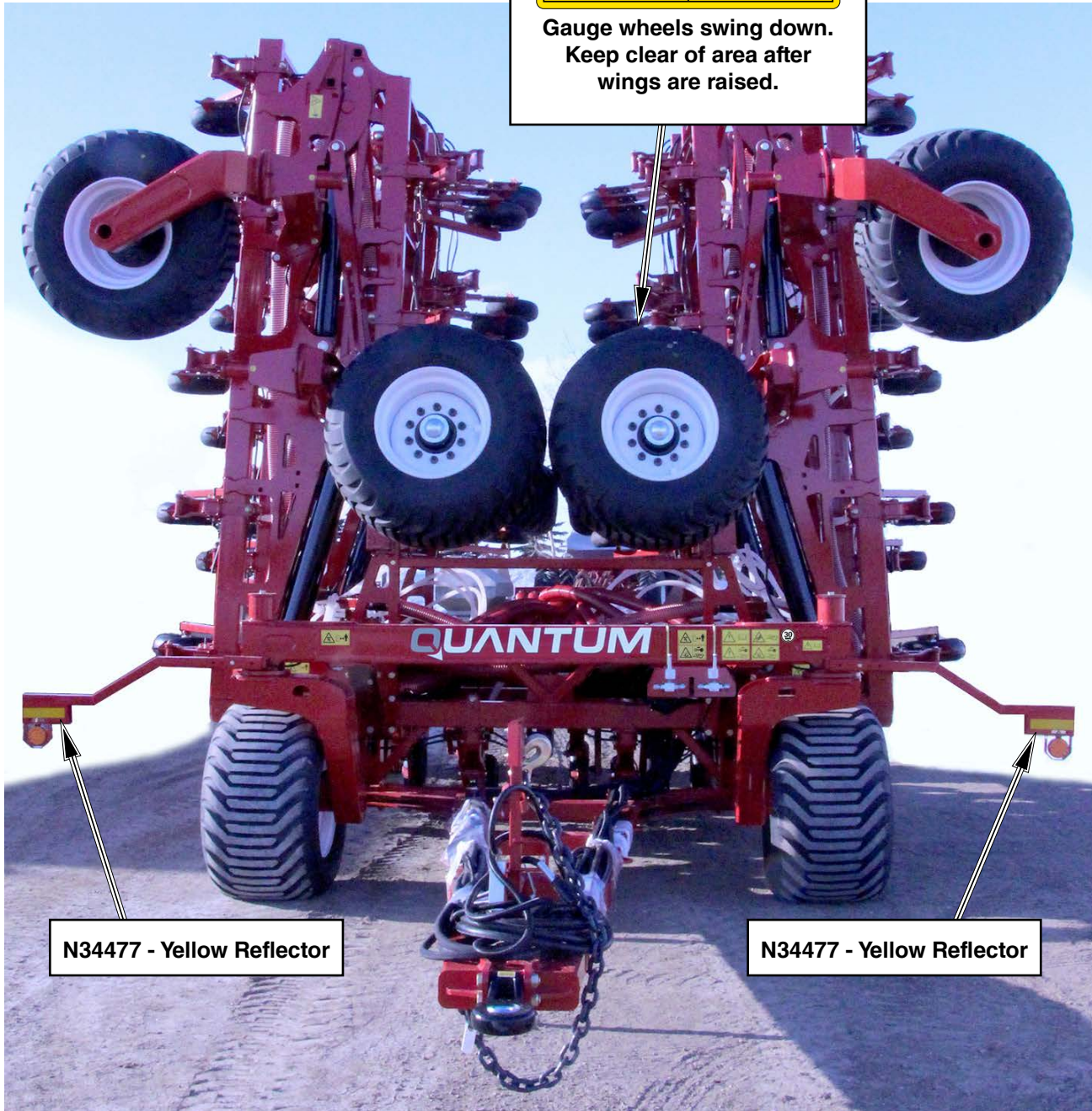

Lighting and Marking - Continued

Side View



Safety

Notes

Section 2: Specifications

Section Contents

Specifications and Options	2-2
Transport Dimensions	2-4

Specifications

QUANTUM AIR DRILL Specifications and Options

Base Size	Models						
	40' or 12 m	50' or 15 m	60' or 18 m	70' or 21 m	80' or 24 m		
Weight Cast Row Units (Includes Double Shoot Distribution)	- 10" Spacing	28,289 lb	32,750 lb	41,721 lb	45,182 lb	66,100 lb	65,700 lb
	250 mm Spacing	12,832 kg	14,855 kg	18,924 kg	20,494 kg	29,982 kg	29,801 kg
	- 12" Spacing	26,605 lb	30,680 lb	39,115 lb	42,120 lb	63,400 lb	63,000 lb
	300 mm Spacing	12,068 kg	13,916 kg	17,742 kg	19,105 kg	28,758 kg	28,576 kg
	- 15" Spacing	24,971 lb	28,570 lb	36,649 lb	39,258 lb	N/A	N/A
	380 mm Spacing	11,327 kg	12,959 kg	16,624 kg	17,807 kg		
Working Width	- 10" (250 mm)	40' (12 m)	50' (15 m)	60' (18 m)	70' (21 m)	80.83'	24 m
	- 12" (300 mm)	40' (12 m)	50' (15 m)	60' (18 m)	70' (21 m)	80.70'	24 m
	- 15" (380 mm)	40' (12.16 m)	50' (15.2 m)	60' (18.24 m)	70' (21.28 m)	N/A	N/A
Number of Shanks	- 10" (250 mm)	48	60	72	84	97	95
	- 12" (300 mm)	40	50	60	70	82	80
	- 15" (380 mm)	32	40	48	56	N/A	N/A
Frame Width	- Main	14.35' (4.37m)	14.35' (4.37m)	14.35' (4.37m)	14.35' (4.37m)	19.25' (5.87m)	
	- Wing Inner	13.60' (4.15m)	13.60' (4.15m)	13.65' (4.16m)	15.65' (4.77m)	13.65' (4.16m)	
	- Wing Outer	-	-	10.15' (3.09m)	13.16' (4.01m)	10.77' (3.28m)	
	- Flip Wing	-	5.03' (1.53m)	-	-	5.98' (1.82m)	
Transport Position	- Width	17' 10" (5.44m)	17' 10" (5.44m)	17' 10" (5.44m)	17' 10" (5.44m)	25.10' (7.65m)	
	- Height	16' 10" (5.13m)	16' 10" (5.13m)	16' 10" (5.13m)	19' 1" (5.82m)	18.35' (5.59m)	
	- Length	33.83'(10.31m)	33.83'(10.31m)	33.83'(10.31m)	33.83'(10.31m)	33.83' (10.31m)	
Tires	- Main Frame Front Castor Wheels	Single Castor (2) 600/50R22.5	Single Castor (2) 600/50R22.5	Single Castor (2) 600/50R22.5	Single Castor (2) 600/50R22.5	Dual Castor (4) 445/50R22.5	
	- Main Frame Rear Wheels	Single Axle (2) 600/50R22.5	Single Axle (2) 600/50R22.5	Single Axle (2) 600/50R22.5	Single Axle (2) 600/50R22.5	Dual Walking Beam (4) 445/50R22.5 or Single Axle (2) 650/55R26.5	
	- Wing Frame Front Castor Wheels	Single Castor (2) 600/50R22.5	Single Castor (2) 600/50R22.5	Single Castor (4) 600/50R22.5	Single Castor (4) 600/50R22.5	Single Castor (4) 600/50-22.5	
	- Wing Frame Rear Wheels	(1 per wing) (2) 600/50R22.5	(1 per wing) (2) 600/50R22.5	(1 per wing) (4) 600/50R22.5	(1 per wing) (4) 600/50R22.5	(1 per wing) (4) 600/50-22.5	
Opener	- Trip Out Force	Maximum 800 lbs (363 kg) at 1200 psi (8274 kPa)					
	- Packing Force	100 lbs to 230 lbs (45 kg - 104 kg)					
	- Packer Wheel	4.50" x 16" Semi Pneumatic 5.50" x 16" Semi Pneumatic Otico tire 5.50" x 16" Semi-Pneumatic 4.00" x 16" "V" Crown					
Opener to Ground Clearance	12" (30.5 cm)						
Frame to Ground Clearance	36" (91.4 cm)						
Frame Depth	84" (213.4 cm) center to center						
Rank to Rank Spacing	42" (106.7 cm) center to center						
Number of Ranks	3 Rows 4th Row Optional on 40 ft to 70 ft and is standard on 80 ft.						
Shank to Shank Spacing	30" (750 mm) on 10" (250 mm) Spacing 36" (900 mm) on 12" (300 mm) Spacing 45" (1140 mm) on 15" (380 mm) Spacing						
Weight Kit	Optional						
Safety Lights	Standard						
Hitch Clevis	Standard - Category 4 Optional - Category 5						
Safety Chain	Standard						

Specifications are estimates and subject to change.

Transport Dimensions

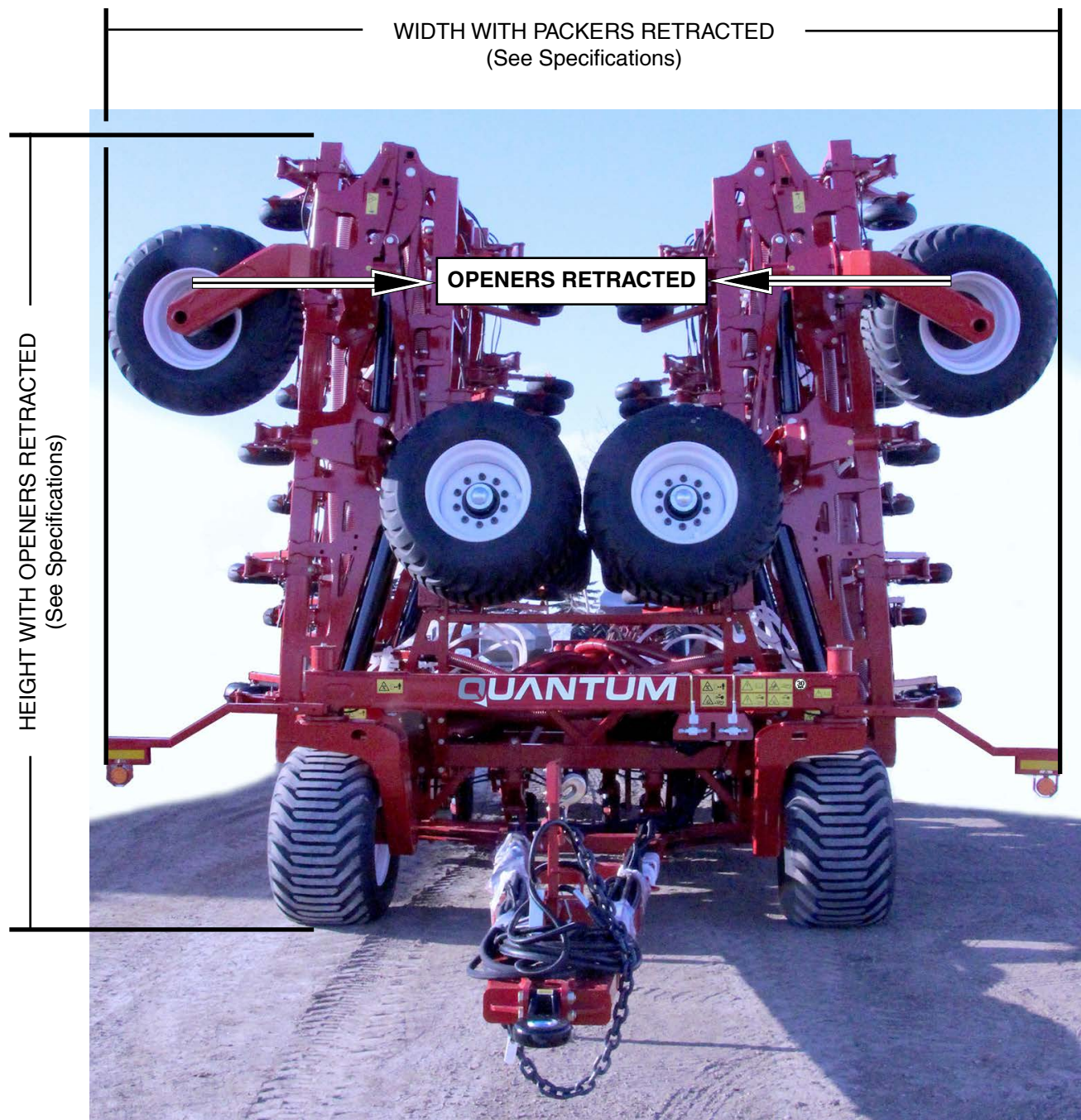

Specifications

Notes

Section 3: Checklist

Section Contents

Manuals	3-2
Checklist	3-3

Checklist

SAFETY-ALERT SYMBOL



Watch for this symbol. It identifies potential hazards to health or personal safety. It points out safety precautions. It means:

ATTENTION - BE ALERT.
Your safety is involved.

Manuals

Note: Pre-Delivery Inspection Form must be completed and submitted to Morris Equipment within 30 days of delivery date.

Warranty Void if Not Registered

Parts Manual

Order Part Number S66247

Assembly Manual

Order Part Number S66248 (Metric)

Order Part Number S66249 (Imperial)

Checklist

Please read the Operator's Manual carefully and become a "SAFE" operator.

Adopt a good lubrication and maintenance program.

General

- ___ Check if assembled correctly.
- ___ Check hose connections.

Lubrication - Grease

- ___ Opener Wheel Hubs
- ___ Wheel Hubs
- ___ Castor Pivots

Tire Pressure

- ___ See tire chart in Maintenance, Section 6.

Transport

- ___ Tighten wheel bolts.
- ___ Check hose connections.
- ___ Ball valves are in locked position.

OWNER REFERENCE

Model: _____
Serial No: _____
Dealer: _____
Town: _____ State: _____
Phone: _____
OWNER/OPERATOR _____
Date: _____



TAKE SAFETY SERIOUSLY.

**DO NOT TAKE
NEEDLESS CHANCES!!**

Checklist

Notes

Section 4: Introduction

Section Contents

Introduction.....	4-2
Active Hydraulic System	4-3

Introduction

Introduction

This Operator's Manual has been carefully prepared to provide the necessary information regarding the operation and adjustments, so that you may obtain maximum service and satisfaction from your new MORRIS QUANTUM AIR DRILL.

To protect your investment, study your manual before starting or operating in the field. Learn how to operate and service your QUANTUM AIR DRILL correctly, failure to do so could result in personal injury or equipment damage.

If you should find that you require information not covered in this manual, contact your local MORRIS Dealer. The Dealer will be glad to answer any questions that may arise regarding the operation of your MORRIS QUANTUM AIR DRILL.

MORRIS Dealers are kept informed on the best methods of servicing and are equipped to provide prompt efficient service if needed.

Occasionally, your QUANTUM AIR DRILL may require replacement parts. Your Dealer will be able to supply you with the necessary replacement parts required. If the Dealer does not have the necessary part, the MORRIS Factory will supply the Dealer with it promptly.

Your MORRIS QUANTUM AIR DRILL is designed to give satisfaction even under difficult conditions. A small amount of time and effort spent in protecting it against rust, wear and replacing worn parts will increase the life and trade-in value.



Keep this book handy for ready reference at all times. It is the policy of Morris Equipment Ltd. to improve its products whenever it is possible to do so. The Company reserves the right to make changes or add improvements at any time without incurring any obligation to make such changes on machines sold previously.

Active Hydraulic System

The active hydraulic system uses a special manifold block (S64940) which controls the Lift-Lower and packing pressure functions through a controller and an in cab display.

The controller and display provides the user the ability to adjust the opener downforce packing pressure on the go from inside the cab while applying product.

As well as push button convenience to Lift and Lower the openers from the Transport into the Working position.

Two control options are available to suit Ground Drive and VRT/ICT style Air Carts.

- a) JEM - CC PILOT and ESX Controller
- b) Topcon - Apollo CM-40 Master module

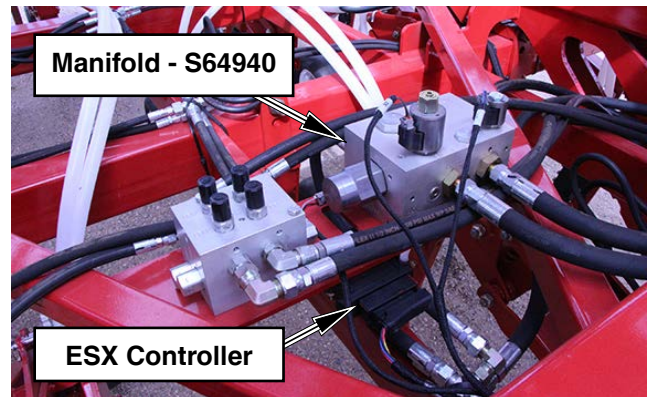

Option A:

Vansco equipped Ground Drive units must be configured with a JEM CC Pilot Drill Control system package.

Option B:

Topcon equipped Air Carts (VRT, ICT) units can be configured to use Apollo Lift Control / Pack Control.

Topcon Apollo Equipped Air Carts can also control the QUANTUM Lift/Lower functions and Pressure settings*.

Lift Control will automatically Lift/Lower the openers when entering and exiting a headlands or previous applied coverage.

***Note: Pack Control - (Opener Pressure Control) requires a complete spare drive channel on Apollo ECU. A 4 Tank Cart would require an additional CM-40.**

For 9 Series Air Carts refer to X35 Manual N65100 for details on operating the Pack Control System.

For 10 Series Air Carts refer to XD+ Manual N73902 for details on operating the Pack Control System.



JEM CC PILOT Display Screen and ESX Controller



Topcon X35 Apollo - Lift Control / Pack Control

Warning

Openers drop with full down force when powering up or rebooting the controller with hydraulics engaged.

Ensure opener hydraulic system is disabled before working underneath machine.

Introduction

Notes

Section 5: Operation

Section Contents

Application	5-2
Tractor	5-2
Hitching	5-3
Hitching to Tractor	5-3
Unhitching from Tractor	5-4
JEM CC Pilot Display Wiring	5-5
9 Series Air Cart X35 Apollo - Lift and Pressure Control Wiring	5-6
10 Series Air Cart XD+ Apollo - Lift and Pressure Control Wiring	5-8
Hydraulic Flow Adjustment	5-10
Controller Options	5-11
JEM CC Pilot Display	5-11
Transport	5-12
Transport to Field Position	5-13
Field to Transport Position	5-14
Opener Hydraulic System	5-15
Basic function of the system	5-15
Lifting/Lowering	5-15
Pressure Setting	5-16
Operating Pressure Adjustment	5-17
Field Operation	5-19
Depth Adjustment	5-20
Work Switch	5-22
General Guidelines	5-23
Quick Tips	5-24
Shank Trip Force	5-24
Packing Force	5-24
Hydraulic System	5-24
Lifting and Lowering the Openers	5-24
Setting the Seed Depth	5-25
Seeding Conditions	5-25
Straw Management	5-25
Air Drill Frame	5-26
Wing Lift Hydraulics	5-27
Opener Hydraulics	5-29

Operation

CAUTION



BE ALERT

SAFETY FIRST

**REFER TO SECTION 1 AND REVIEW ALL
SAFETY RECOMMENDATIONS.**

Application

The Morris QUANTUM DRILL utilizes independent parallel link openers. Each opener moves independently of the frame and each other to follow every contour of the land closely. The unique design of the opener allows the Morris QUANTUM DRILL to be used in a variety of seeding applications from conventional to zero till applications.

Tractor

Tires

- Proper ballast and tire pressure are required when pulling heavy implements.
- Consult your tractor operator's manual and follow all recommended procedures.

Hydraulics

- Wipe all hydraulic fittings and couplers with a clean cloth to avoid contaminating the system.
- Check that hydraulic reservoir is filled to the proper level.

Drawbar

- Centre and pin in a fixed position for easier hitching and greater stability.



Warning

Do not permit smoking, sparks or an open flame where combustible fuels are being used. Keep the work area well ventilated.



Warning

Do not search for high pressure hydraulic leaks without hand and face protection. A tiny, almost invisible leak can penetrate skin, that requires immediate medical attention.

Hitching

Caution

A safety chain will help control towed machines should it accidentally separate from the drawbar while transporting. A runaway machine could cause severe injury or death. Use a safety chain with a strength rating equal to or greater than the gross weight of the towed machines.

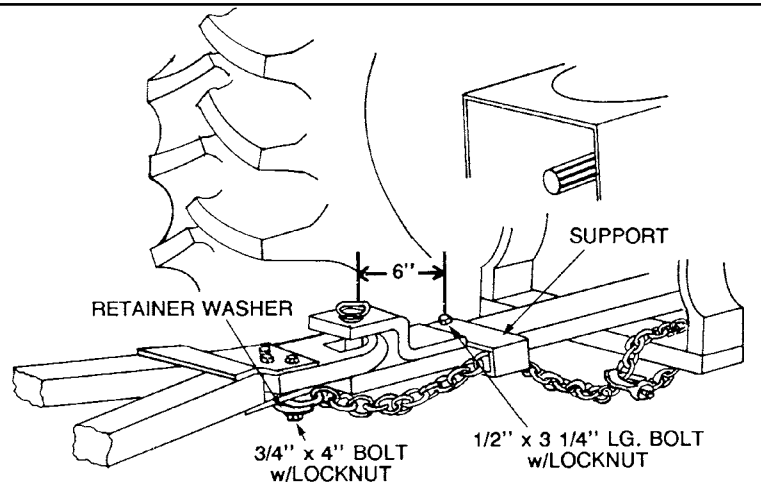

Attach safety chain to the tractor drawbar support or other specified anchor location with the appropriate parts.

Hitching to Tractor

- Ensure swinging drawbar is locked in the centre position.
- Ensure hitch pin is in good condition.
- Level clevis with tractor drawbar using hitch jack.
- Back tractor into position and attach hitch clevis to drawbar, using an adequate hitch pin.
- Lock hitch pin in place with a hairpin or other proper locking device.
- After tractor to implement connection is made, relieve pressure off the hitch jack.
- Place hitch jack in raised position.
- Route Safety Chain through chain support and drawbar support.
- Lock safety hook onto chain.

Note: Provide only enough slack in chain to permit turning.

- Ensure hydraulic hose quick couplers are dirt free.
- Inspect all fittings and hoses for leaks and kinks. Repair as necessary
- Connect the hydraulic hoses to the tractor quick couplers. Opener lift / lower Hydraulics are normally connected to the #1 SCV.

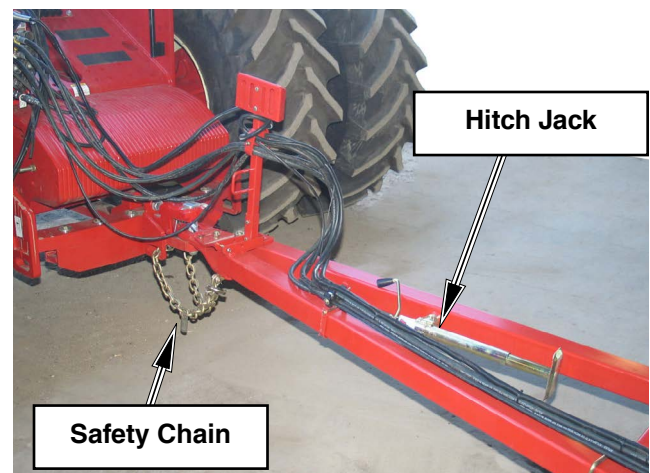

Hitch Jack Raised

Caution

Dirt in the hydraulic system could damage O-rings, causing leakage, pressure loss and total system failure.

Operation

Hitching - Continued

Hitching to Tractor - Continued

- Mount the JEM Display in tractor cab with the LCD visible and with in easy reach to operate. See next page for harness details.
- Route the JEM harness away from moving parts and sharp protrusions. Connect the red wires to the positive (+) terminal of the battery. Connect the black wires to the negative (-) terminal of the battery.
- If equipped with a Topcon X35 Apollo system refer to X35 Operator's Manual N65100. See page 5-6 and 5-7 for harness details.
- **Tractor Hydraulics** - Set the tractor SCV to 40% see "Tractor User Guide" for setting of Hydraulic systems
Tractor SCV should be set to 25gpm.

If not set the QUANTUM opener valve block will flow up to 35 gpm which could starve the oil flow from the Air Cart Fan.

Refer to tractor manufactures information for optimal plumbing of hydraulic system.



Unhitching from Tractor

- Pin hitch jack in storage position.
- Lower hitch jack taking the weight off the hitch clevis.
- Ensure all transport locks are properly secured.
- Relieve pressure in the hydraulic hoses by positioning tractor hydraulic lever in "float" position or turn tractor engine off and cycle lever back and forth several times.
- Disconnect wire harnesses and hydraulic hoses.
- Remove the safety chain.
- Remove the drawbar pin.
- Slowly move tractor away from Air Drill.



Hitch Jack Lowered

Hitching - Continued

JEM CC Pilot Display Wiring

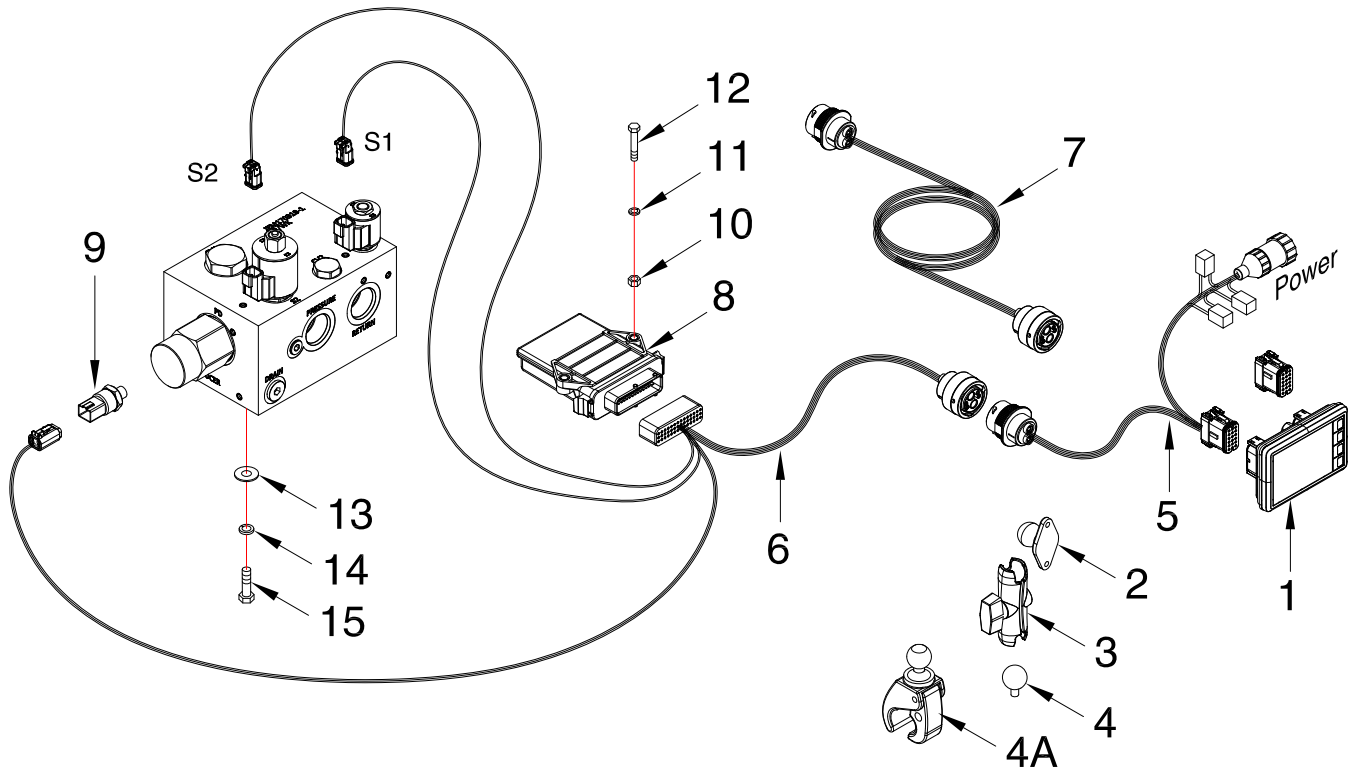

Item	Part No.	Description	Qty
1	N72180	CC Pilot Display Version 2 - 3 1/2 Full Color	1
2	N45644	Ram Mount - 1 7/16 x 1 5/16.....	1
3	N65147	Ram Short Arm	1
4	N65148	Ram Ball - 1 Diameter.....	1
4A	N65146	Ram Claw Mount	
5	N65141	Harness - Tractor (1000545)	1
6	N65142	Harness - Implement (1000546)	1
7	N65149	Harness - Extension (Tow Between Carts) (1000626)	1
8	N65143	ESX-10Xp ECU.....	1
9	K62977	Pressure Transducer	1
10	W-512	Hex Nut - 1/4	2
11	W-521	Lockwasher - 1/4.....	2
12	C-1471	Hex Bolt - 1/4 x 1 3/4 Lg.....	2
13	W-538	Flatwasher - 7/16 ID x 1 OD x 14 GA.....	4
14	W-523	Lockwasher - 3/8.....	4
15	W-475	Hex Bolt - 3/8 x 1 Lg.....	4
	N72181	CC Pilot Display Kit - (Includes Items 1 to 4)	

Operation

Hitching - Continued

9 Series Air Cart X35 Apollo - Lift and Pressure Control Wiring

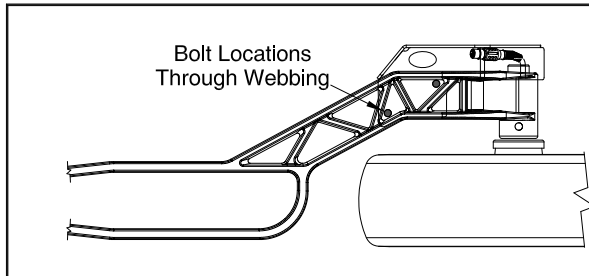
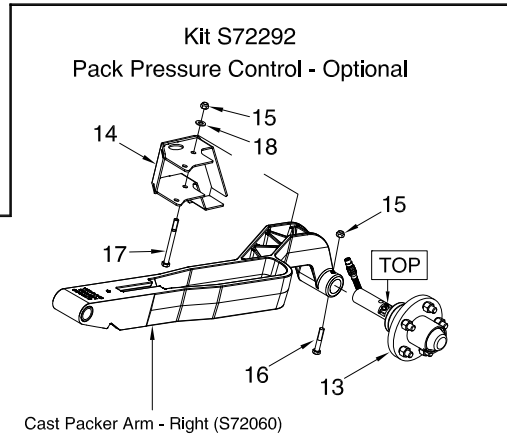
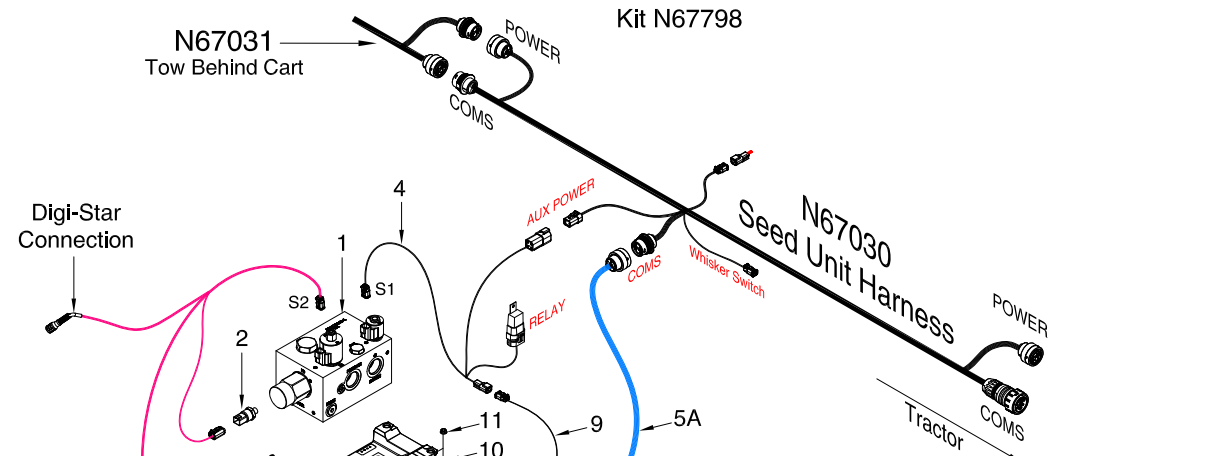
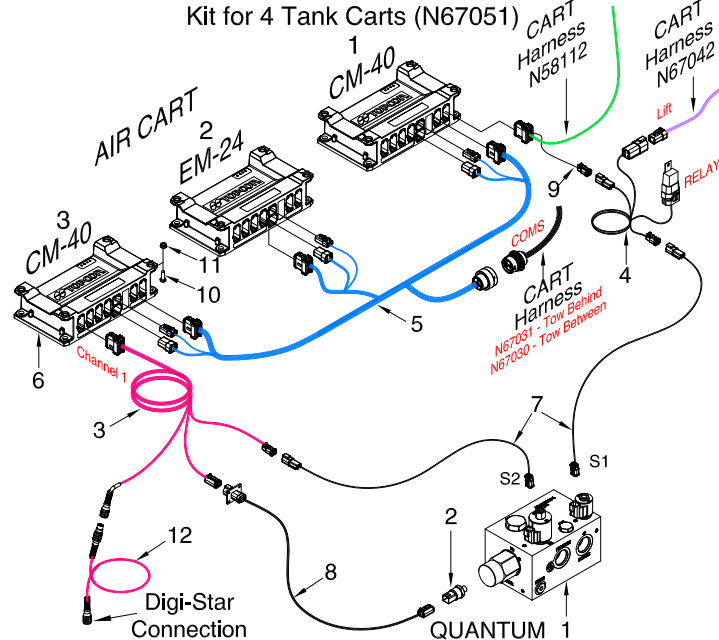
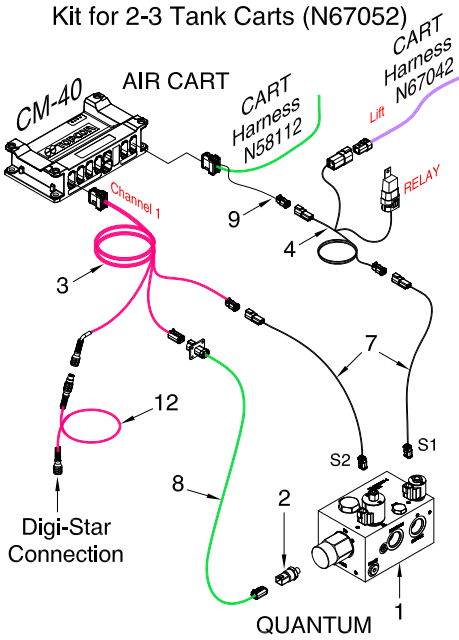

Hitching - Continued

9 Series Air Cart X35 Apollo - Lift and Pressure Control Wiring - Continued

Item	Part No.	Description	Qty
1	S64940	Manifold - Opener Control (Requires S68007 see note below).....	1
	S68006	Manifold - Opener Control - 2000 psi (Includes S68007).....	
2	K62977	Pressure Transducer	1
3	N67045	Harness - Pack Control (1026291-01)	1
4	N67046	Harness - Lift Control (1006258-01)	1
5	N67037	Harness - Triplex ECU Adapter (1005038-01).....	1
5A	N67038	Harness - Single ECU (1005036-01).....	1
5B	N68000	Harness Extension - 2m - (1028492-01) - Optional	
6	N68950	Apollo Master Module ECU - CM-40 Series 2 - (1024223-01)	1
7	N59010	Harness Extension - Work Switch - 5m - (AGA4468)	2
8	N64671	Pressure Transducer Extension Harness - 7m - (1024230-01)	1
9	N68001	AUX Lift Lower Signal Adapter	1
10	W-187	Hex Bolt - 3/8 x 1 1/4 Lg - Bolts ECU to plate under manifold	4
11	D-5279	Locknut - 3/8 Serrated Flange.....	4
12	N68002	Extension Cable - Pack Control	1
	N67052	Lift and Pressure Control Kit for 2-3 Tank Carts (Includes Items 3, 4, 7, 8, 9, 12)	
	N67051	Lift and Pressure Control Kit for 4 Tank Carts (Includes Items 3, 4, 5, 6, 7, 8, 9, 12)	
	N67798	Lift and Pressure Control Kit for 4 Tank Carts Tow Behind ONLY (Includes Items 3, 4, 5A, 6, 9, 10,11)	
		Pack Pressure Control - Optional	
	S72292	Pack Force Spindle and Guard Kit. (Includes ALL Items below)	
13	S72190	Packer Hub Assembly (Includes S72200 Spindle - Digi-Star).....	1
14	S72094	Guard - Pack Control - Cast Arm - Right	1
15	M-3388	Lock Nut - 3/8 Unitorque	3
16	W-480	Hex Bolt - 3/8 x 2 1/2 Lg.....	1
17	C-1550	Hex Bolt - 3/8 x 4 Lg.....	2
18	D-5489	Washer - 13/32 ID x 13/16 OD x 16 GA.....	2
		X35 Apollo - Wiring	
		Ensure the Single Purple wire is installed in pin 13 (Relay signal out on the Auxiliary harness) as shown. (Cart Harness N58112)	
		Connect 1006258-01 Lift lower harness to the following connections:	
		Trunk /Whisker - to the single wire connection to pin 13 on Aux harness	
		Relay Power - to AGA5343 ECU harness DTP power connector - (remove dust cap).	
		Lift Solenoid - to S1 on JEM Manifold block on Quantum drill	

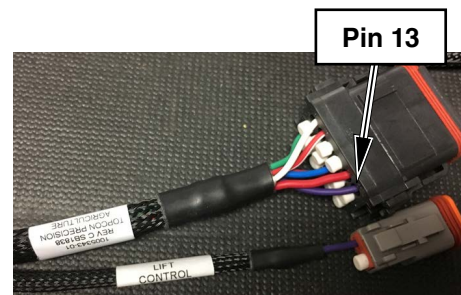

Operation

Hitching - Continued

10 Series Air Cart XD+ Apollo - Lift and Pressure Control Wiring

Tow Behind Configuration

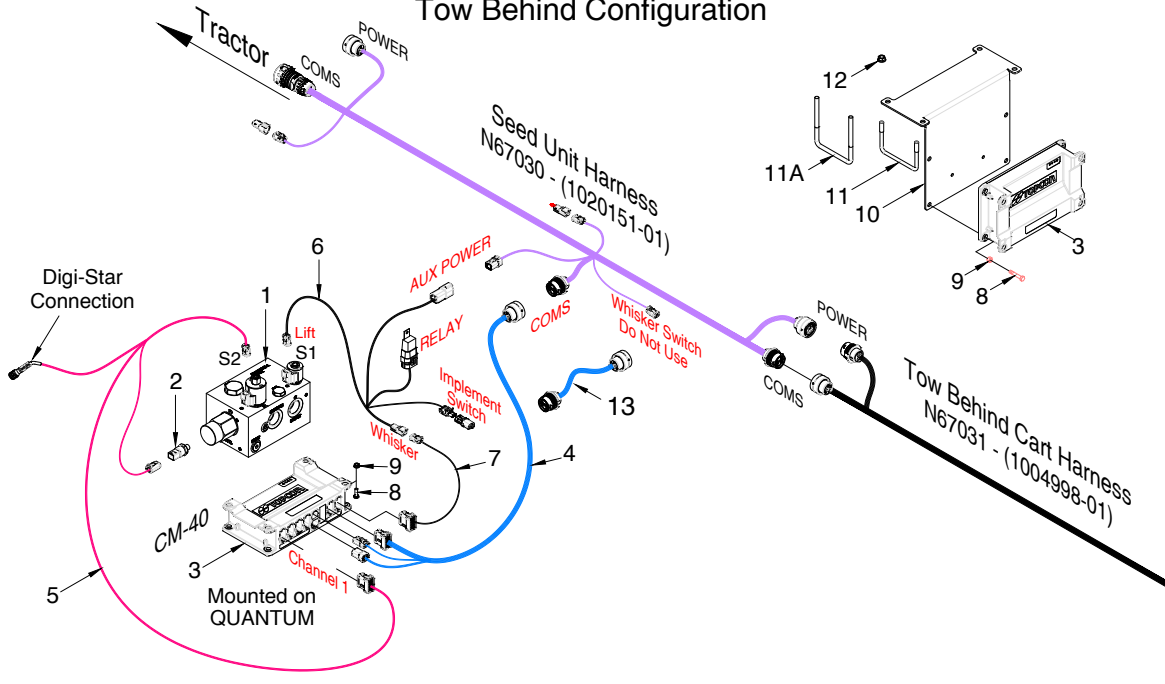

Tow Between Configuration

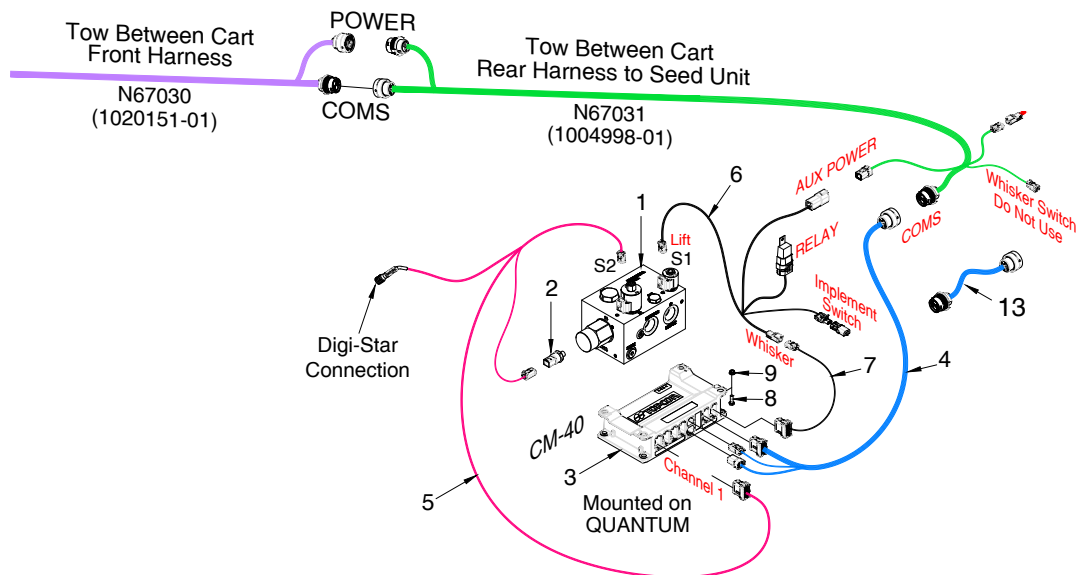

Kit S72292 Pack Pressure Control - Optional

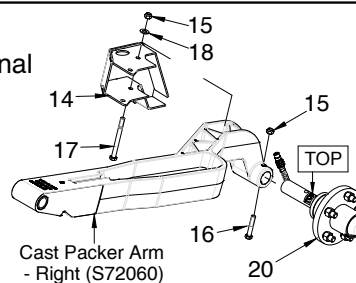
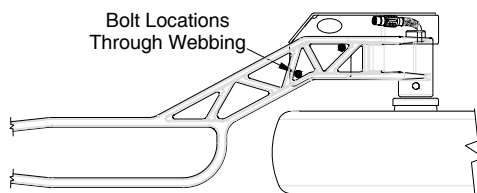

Hitching - Continued

10 Series Air Cart XD+ Apollo - Lift and Pressure Control Wiring - Continued

Item	Part No.	Description	Qty
1	S68006	Manifold - Opener Control - 2000 psi (Includes S68007).....	1
2	K62977	Pressure Transducer	1
3	N74222	Apollo Master Module ECU - CM-40 - E-Drive Version (1069705-01).....	1
4	N67038	Harness - Single ECU (1005036-01).....	1
5	N67045	Harness - Pack Control (1026291-01)	1
6	N67046	Harness - Lift Control (1006258-01).....	1
7	N68001	AUX Lift Lower Signal Adapter	1
8	W-187	Hex Bolt - 3/8 x 1 1/4 Lg - Bolts ECU to plate under manifold	4
9	D-5279	Locknut - 3/8 Serrated Flange.....	4
	N74270	Lift and Pressure Control Kit (Includes Items 3, 4, 5, 6, and 7)	
		ECU Relocation Mount Kit - Optional Relocates CM-40 to front truss tube.	
10	S73263	Mount Plate	1
11	D-4932	U-Bolt - 3/8.....	2
11A	N15098	U-Bolt - 3/8 x 4 x 5	2
12	S27987	Lock Nut - 3/8 Flanged.....	4
13	N68000	Harness Extension - 2m - (1028492-01)	1
	S73264	Relocation Mount Kit - 40 ft to 70 ft (Includes Items 10, 11 and 13)	
	S73265	Relocation Mount Kit - 80 ft (Includes Items 10, 11A and 13)	
		Pack Pressure Control - Option	
	S72292	Pack Force Spindle and Guard Kit. (Includes ALL Items below) - 2022 to Present	
14	S72094	Guard -Pack Control - Cast Arm - Right	1
15	M-3388	Lock Nut - 3/8 Uunitorque	3
16	W-480	Hex Bolt - 3/8 x 2 1/2 Lg.....	1
17	C-1550	Hex Bolt - 3/8 x 4 Lg.....	2
18	D-5489	Washer - 13/32 ID x 13/16 OD x 16 GA.....	2
19	D-4838	Nylon Tie Strap - 3/16 x 7 1/2 Lg.....	2
20	S72190	Packer Hub Assembly (Includes S72200 Spindle - Digi-Star).....	1

Operation

Hydraulic Flow Adjustment

With the unit in field position perform a hydraulic flow check.

- Perform a visual inspection for bystanders around and/or under the Quantum Drill once clear, proceed to rotate the Openers ball valve into opener unlocked position.
- Push the Opener Hydraulic lever forward until it locks into continuous operation.
- **Tractor SCV should be set to 25 gpm** which is usually around a setting of 40% see “Tractor User Guide” for setting of Hydraulic systems.

If not set the QUANTUM opener valve will flow up to 35 gpm which could starve the oil flow from the Air Cart Fan.

With the tractor hydraulics engaged check the Controller Up/Down function of the openers.

Note: If the openers do not raise or lower correctly, reverse the hydraulic hoses on the tractor.

- Once satisfied that the openers are lifting and lowering correctly, bring Fan 1 and Fan 2 up to normal operating speed on the Air Cart.
- Perform additional raising and lowering tests of the drill, however pay close attention to the Fan speed.
- The Morris Quantum drill should be able to lower into the working position within 7 seconds without any substantial fan speed interruption.
- Total Fan speed should not drop by more than **300 rpm** while the drill is lowered.
- If excessive fan speed drop is experienced the operator will need to adjust Opener flow to keep Fan rpm consistent.



Warning

Openers drop with full down force when powering up or rebooting the controller with hydraulics engaged.

Ensure opener hydraulic system is disabled before working underneath machine.

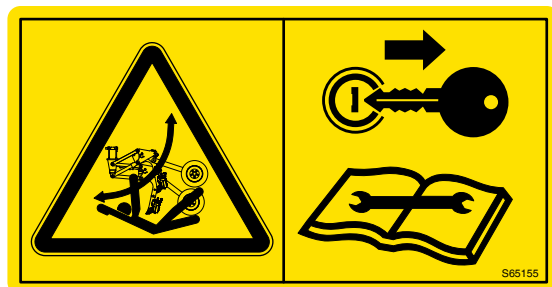

Controller Options

Two control options are available to suit Ground Drive and VRT/ICT style Air Carts.

- JEM - CC PILOT and ESX Controller
- Topcon - X35 Apollo CM-40 Master module. Refer to X35 Manual N65100 for details on operating the Pack Control System.

JEM CC Pilot Display

Opener: (S1) Opener valve is either Up / Down

Pressure: (S2) Pressure Reducing valve set point adjusted by pressing the Pressure Increase / Pressure Decrease keys displayed

Digital %: Displays percentage open of S2 valve.

PSI Analogue Gauge: Displays **actual system** pressure from Pressure Transducer K62977.

Comm: Icon is only visible when there is no communication with the ESX Controller.

PSI Boost: Pressure Boost is active for 4 seconds after setting the OPENER DOWN.

Revision Level: Viewed when both “PRESSURE INCREASE” and “PRESSURE DECREASE” buttons are held down together.

Features:

- CC Pilot holds the last pressure used, example if the last entered pressure was set at 800 psi (5516 kPa) from the previous day upon powering on the unit the value will return automatically to the last value used of 800 psi (5516 kPa).
- Buzzer alarms when Pressure exceeds 1350 psi. (9308 kPa) (alarm is not user settable) the controller will auto adjust pressure back to 1350 psi.

Note: The operating temperature of the hydraulic fluid will affect the relation between the S2 % value and the actual system pressure. Adjust the S2 % value accordingly to maintain desired system pressure.

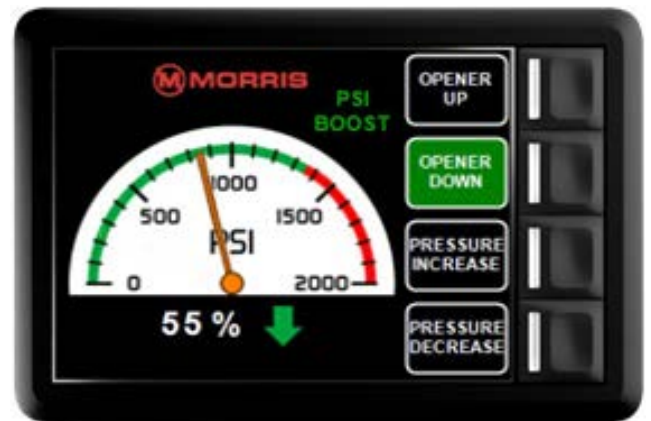
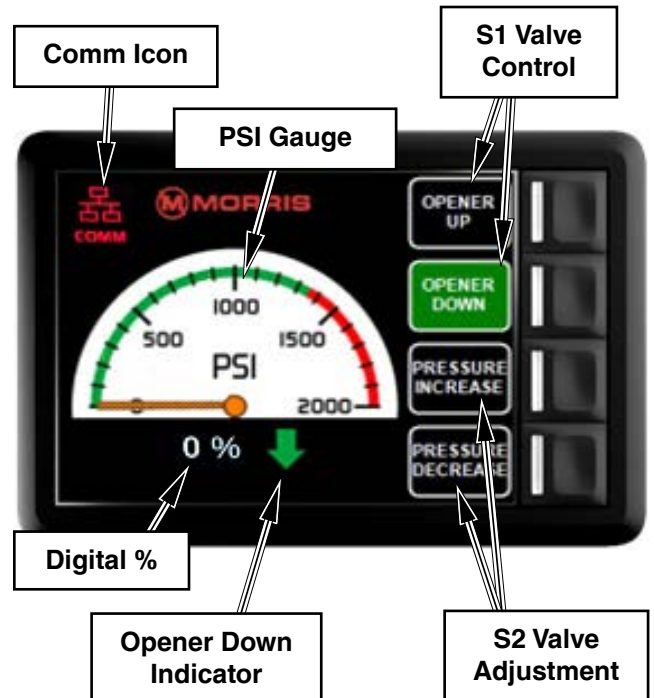

Operation

Transport

Observe all applicable safety precautions under transport heading in Safety, Section 1.

- Refer to Specifications, Section 2, for weight, transport height, and width.
- Transport with tractor only!
- Ensure safety chain is attached correctly to the towing vehicle and the hitch of the implement.
- Inspect tires for any serious cuts or abrasions. If such has occurred, tire should be replaced.
- Raise and lower wings on **level ground**.
- Never raise or lower wings when moving.

Speed

- Always travel at a safe speed. Do Not Exceed 20 mph (30 km/h).
- The combined weight of the implements being towed, including material in tank, **must not exceed 1.5 times** the weight of the towing tractor.
- Use additional caution when towing loads under adverse surface conditions, when turning, and on inclines.

Lights

- Ensure proper reflectors are in place, refer to Safety, Section 1.
- Use flashing amber warning lights, turn signals and SMV emblems when on public roads.
- Be familiar with, and adhere to, local laws.

MORRIS EQUIPMENT LTD. WILL NOT BE RESPONSIBLE FOR ANY DAMAGES OR OPERATOR INJURY RESULTING FROM NON-USE OR IMPROPER USE OF TRANSPORT LOCKS.

Caution

Raise and lower wings on level ground. Never raise or lower wings when moving.



Over Head Hazard

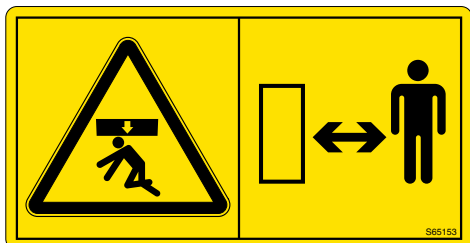

Gauge Wheels swing down.

Keep clear of area after wings are raised.



Transport - Continued

Transport to Field Position

- Position machine on **level ground**.
- Stop tractor, and engage park brake.
- As a precaution, check surrounding area to be sure it is safe to lower wings.
- Unlock the wing valve and opener valve. Do not walk under raised wings.
- Operate opener hydraulics, to ensure all openers are retracted.
- Operate wing lift hydraulics until wings are lowered and the cylinder shafts are completely extended to allow wings to float when working in uneven land. **Never raise or lower wings when moving.**

Note: When raising or lowering wings, do so in one continuous motion until fully up or down. Do not stop flow part way allowing wings to fold on their own. This may disrupt the sequence of operation.

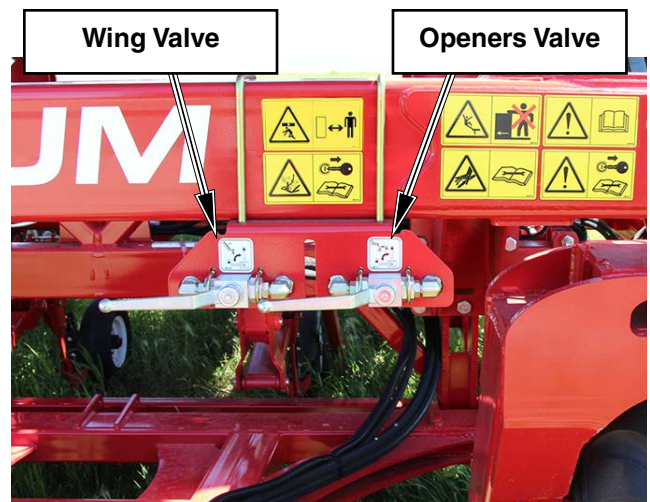
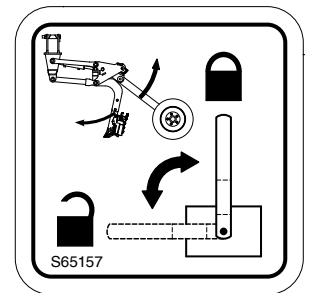
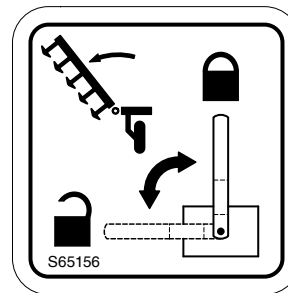

Valves in Unlocked Position

Danger: Crushing Hazard

To prevent death or serious injury:

Always stay clear of wings being raised, lowered or in elevated position. Ensure cylinders are completely filled with hydraulic fluid - wings may fall rapidly causing injury or death.

Over Head Hazard - Gauge Wheels swing down. Keep clear of area after wings are raised.

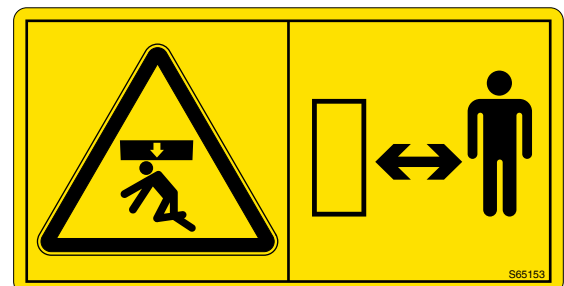

Operation

Transport - Continued

Field to Transport Position

- Position machine on **level ground**.
- Stop tractor, and engage park brake.
- Ensure wing lift cylinders are fully extended.

Note: The wing lift cylinders must be fully extended to ensure proper operation of the flow control valve (FCV) manifold.

- Operate the opener hydraulics, to raise the openers fully.
- Disengage the tractor remote and turn the Control Console off. (JEM CC Pilot or Topcon X35)
- Operate the wing lift hydraulics, to raise the wings fully into transport position. **Never raise or lower wings when moving.**

Note: When raising or lowering wings, do so in one continuous motion until fully up or down. Do not stop flow part way allowing wings to fold on their own. This may disrupt the sequence of operation.

- Lock wing lift valve and opener valve. Do not walk under raised wings.
- Ensure safety chain is properly installed, see “Hitching to Tractor” of the Operation Section.

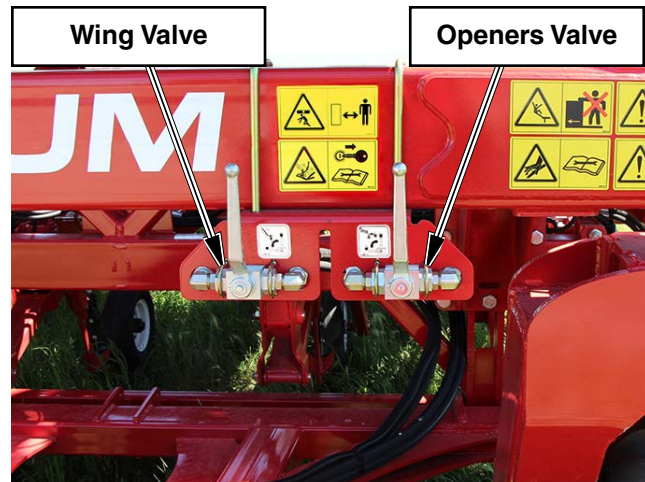
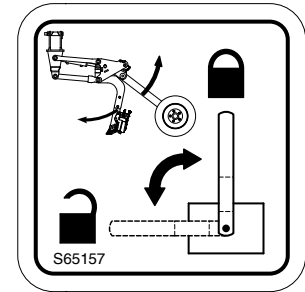
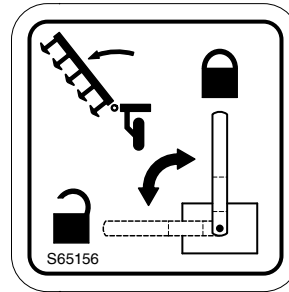

Valves in Locked Position

Danger: Crushing Hazard

To prevent death or serious injury:

Always stay clear of wings being raised, lowered or in elevated position. Ensure cylinders are completely filled with hydraulic fluid - wings may fall rapidly causing injury or death.

Over Head Hazard - Gauge Wheels swing down. Keep clear of area after wings are raised.

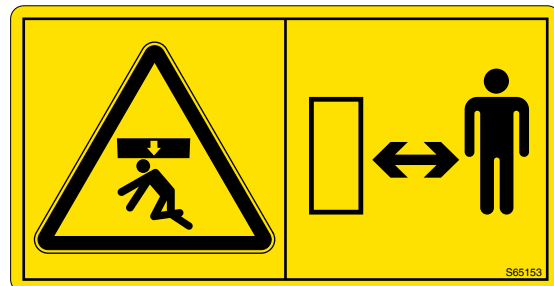

Opener Hydraulic System

Basic function of the system

- Tractor remote is set to continuous flow connected to the “Pressure” port on the Opener Control Block.
- Control the Lift-Lower and packing pressure functions through JEM display or X35 monitor.

WARNING: Openers will drop with full operating force if the JEM display or X35 monitor is rebooted with hydraulics running.

- Flow requirements during operation will be a continuous (3-4 gpm max) (11-15 lpm) for most conditions, but large changes in terrain (drainage ditches, terraces, water runs) will cause larger flow rates for short intervals. Minimum oil flow rate for the opener circuit would be 18 gpm (68 lpm); 25 gpm (95 lpm) is optimal. Lower flow rate = slower operation on headlands. Flow requirements are highest while lifting/lowering openers at headlands where full flow of the hydraulic remote will occur.

Note: Operate system at the lowest system pressure that will keep shanks locked vertical during seeding and provide adequate packing pressure. Excessive hydraulic pressure may disturb rocks and damage carbides.

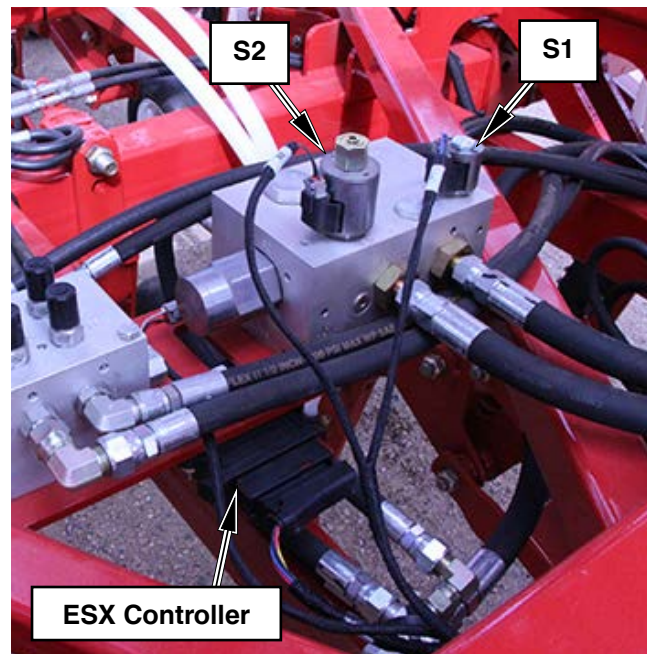

Lifting/Lowering

- Pressing Opener “UP” button on the controller will lift the openers fully up by shifting solenoid valve “S1” to gland side of opener cylinders.
- Pressing Opener “DOWN” button on the controller will lower the openers all the way down and lock them into working position by shifting solenoid valve “S1” to its default position of flow straight through to butt end of opener cylinders.

WARNING: Default valve position is openers down when applying flow at “Pressure” port.

- The system will remember the last mode (“UP” or “DOWN”) that it was operating in and operate in that same mode at next start up.

Note: If the controller is not present or connected, the tractor remote can be used manually to lift and lower the openers although no pressure control will be available; pressure down will be limited to the default of the reducing relieving valve “S2” (200 psi) (1379 kPa).

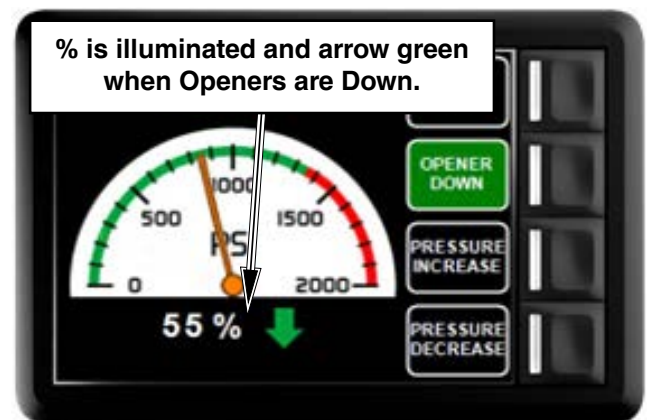
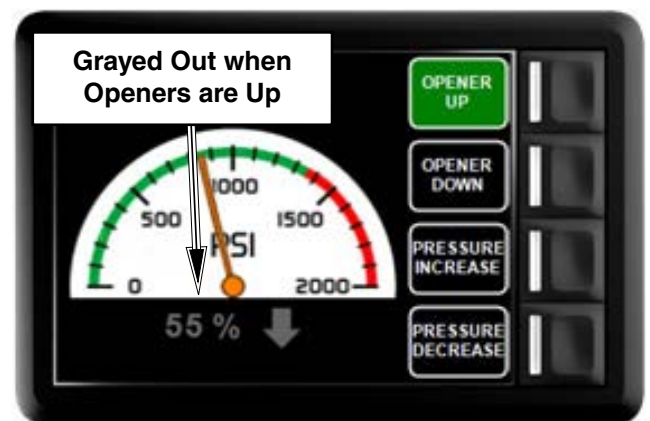

Operation

Opener Hydraulic System - Continued

Basic function of the system - Continued

Pressure Setting

- Pressure can be adjusted on the go from the tractor cab using the display.
- Pressing the “PRESSURE INCREASE” button on the display will increase the pressure by shifting proportional reducing/relieving valve S2 in the block; each press of the arrow will change the % value by 1 or 2% the pressure gauge will indicate psi change.
- Pressing the “PRESSURE DECREASE” button on the display will decrease the pressure by shifting proportional reducing/relieving valve S2 in the block; each press of the arrow will change the % value by 1 or 2% the pressure gauge will indicate psi change.

Note: Holding the button will cause the % to change rapidly for larger changes.

- The system will remember the last pressure setting that it operated at and revert to that at next start up.



In the diagram below, the relevant forces created by the hydraulic pressure applied to the row unit's cylinder are illustrated.

Definitions:

Down Force - vertical force that is pushing the opener downwards due to hydraulic pressure.

Trip Force - horizontal force that is holding the shankholder in place in working position, resisting against soil draft forces.

Soil Draft Force - horizontal force from soil resistance on the shank/opener trying to rotate shank backwards.

Soil Penetration Force - the amount of force required to push the shank/opener vertically into the soil; this varies based on:

- Opener type (single shoot, dual shoot paired row, dual shoot sideband etc).
- Soil type (clay, loam, sandy loam etc).
- Moisture conditions.

Soil Packing Force - the amount of force applied at the packer wheel of the row unit to pack/firm the furrow and maintain depth

Opener Weight - approximate static weight of opener affecting packer force.

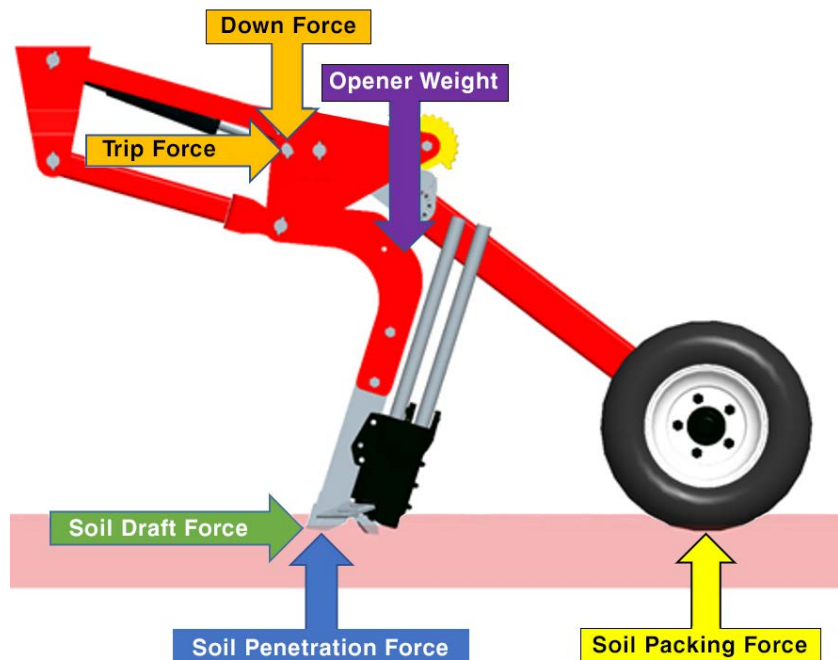

Opener Hydraulic System - Continued

Basic function of the system - Continued

Pressure Setting - continued

The force applied by the hydraulic cylinder is split into two components: down force and trip out force. Geometry also sets the ratio of down force and trip force; as the hydraulic pressure is raised up, down force and trip force both increase.

During operation of the machine, the forces at any given time balance each other out in both horizontal and vertical directions. This means that the applied trip out force balances against the draft load forces and the shank stays locked in working position. Similarly, the applied down force will balance out against the soil penetration force and the applied packing force.

The row unit geometry is designed to produce the following force ratios:

$$\text{Trip Force (lbs)} = \frac{\text{Hydraulic Pressure (psi)}}{1.6^*} \quad \text{*ratio applies for standard Morris shank length}$$

Example: Trip force at 1000 psi = $1000/1.6 = 625$ lbs trip force

Note: Due to the variation of friction effects, this trip force is approximate.

Operating Pressure Adjustment

To determine the operating pressure required, follow these steps to set the opener trip force required for the current field conditions:

1. Set each opener to the required seed depth to ensure the force required to keep the openers engaged in the soil will be the same as it would be during the seeding operation. Refer to "Depth Adjustment" for the correct procedure.
2. Turn Control Console on and set the system pressure, suggested starting pressure is 500 - 600 for light or preworked soil, 700 - 800 for medium soil and 800 - 1000 for heavy soil. Increase pressure if openers are not penetrating the ground.
3. Start across the field at the desired seeding speed and press the Down button to lower the openers into the working position.
4. Increase the hydraulic pressure in 25 lb increments until the shanks are not tripping out excessively. This will be the minimum operating pressure to maintain.

Do not adjust to pressures less than this unless it is necessary (for example if crossing a very wet spot)

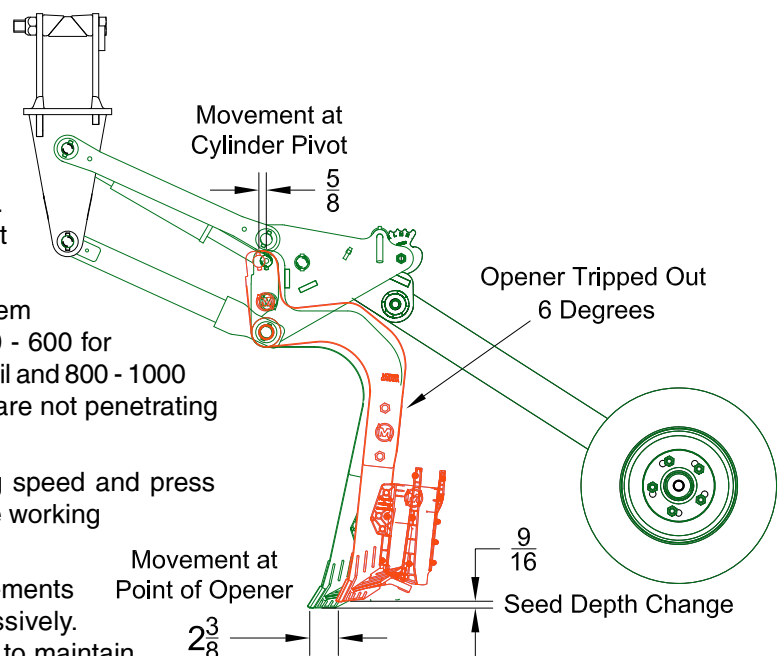

If the minimum operating pressure is set too low this could cause the openers to fall out of the locked working position. This is due to the draft forces of the soil exceeding the system hydraulic pressure, allowing the openers to drag backwards into a partially tripped position. If the opener shank assembly becomes partially tripped the seed depth accuracy will become compromised. Even if the openers are slightly pushed back 6° from the locked working position, the changes in geometry can alter the seed depth by over $\frac{1}{2}$ ". See diagram above.

Operation

Opener Hydraulic System - Continued

Operating Pressure Adjustment - Continued

- Experiment with different hydraulic pressure values to suit field conditions.

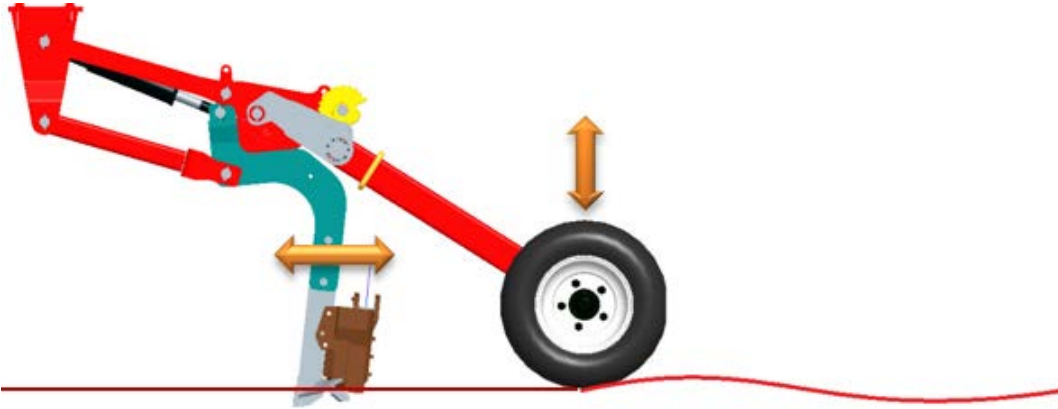

- During a test pass, have someone drive along side the Quantum and inspect the openers. Communicate with each other on the current settings used and if the openers appear to be locked into the working position. If the openers appear to be kicking back or “dancing” increase the Pressure setting by pressing the “INC” button on the display. This will increase the hydraulic pressure in 25 lb increments.
- Set pack force at the minimum value that provides good firming of the soil over the seed and good seed to soil contact; if a lot of “lumps” of soil are noticed in the furrow, more force may be needed to break down these lumps
- Check behind the drill frequently during seeding to ensure adequate soil firmness over the seed in the furrows.

Important: Make sure the openers do not trip excessively and are penetrating the ground properly. Failure to use sufficient down pressure will cause poor seed placement.

Note: Maximum recommended continuous operating pressure of the opener hydraulic system should not be set above 1200 psi while in pressure control mode. Setting pressures above this point may result in damage to the row units, Quantum drill frame and the hydraulic system.



Opener Hydraulic System - Continued

Field Operation

Follow the steps below to setup and operate the unit when starting a new field.

1. Lower unit into field position as outlined under “Transport to Field Position.
2. Engage the Openers and Air Cart fans hydraulic circuits and lock the remotes in the engaged position.
3. Switch the power on for the Control Console and Air Cart monitor.
4. Move forward with the tractor at the desired seeding speed and press down button on the JEM CC Pilot or lift control button on the Topcon X35 to lower the openers into the ground.
5. When the openers are fully engaged, turn on the Air Cart metering system to begin metering product into the airstream.
6. Drive for a reasonable distance so that seed depth can be checked behind the unit.
7. Turn the Air Cart metering system off and stop the unit with the openers engaged in working position.
8. Check the seed depth and soil packing in a few locations across the width of the unit.



Note: Openers running in tire tracks may require additional adjustment.

9. If any depth adjustments are required, adjust the depth cam on each opener. Refer to “Depth Adjustment” for details.
10. If the packing requires adjustment, change pressure setting on the JEM CC Pilot or Topcon X35.
11. Do another test pass to ensure that the desired seed depth and soil packing has been achieved.
12. Begin seeding by;
 - a. At the start of a pass, press down button on the JEM CC Pilot or lift control button on the Topcon X35 to lower the openers.
 - b. As the openers are entering the ground turn on the Air Cart metering.
 - c. Typically, it takes 7 seconds for the openers to lower fully and 3 seconds for product to reach the openers so account for this by switching the Air Cart metering on prior to reaching the unseeded area.
13. When approaching the headland at the end of a pass, first turn off the Air Cart metering as the drill fully enters the headland area.
 - a. After the drill has crossed into the headland area, press up button on the JEM CC Pilot or lift control button on the Topcon X35 to raise the openers.
 - b. Complete the headland turn, then repeat step 12 to start the next pass.
14. After the field is seeded, refer to “Field to Transport Position” for winging up unit.

Travel Distance			
MPH	Feet/second	kph	m/s
3.75	5.50	6	1.67
4	5.87	6.44	1.79
4.25	6.23	6.84	1.90
4.5	6.60	7.25	2.01
4.75	6.97	7.5	2.08
5	7.33	8	2.22
5.25	7.70	8.5	2.36
5.5	8.07	8.85	2.46
5.75	8.43	9.25	2.57
6	8.80	9.66	2.68
6.25	9.17	10	2.78
6.5	9.53	10.46	2.91

Operation

Depth Adjustment

To adjust seed depth:

- Lift openers to raised position.
- Shut tractor off and remove key.
- Ensure tractor park brake is engaged before proceeding.
- Place “Openers” ball valve into locked position to prevent accidental oil flow to openers.

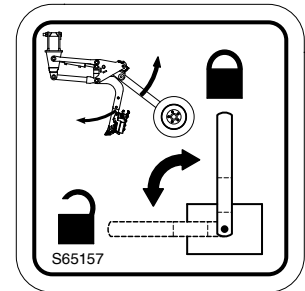
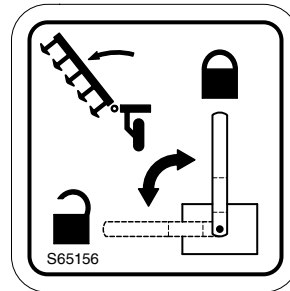
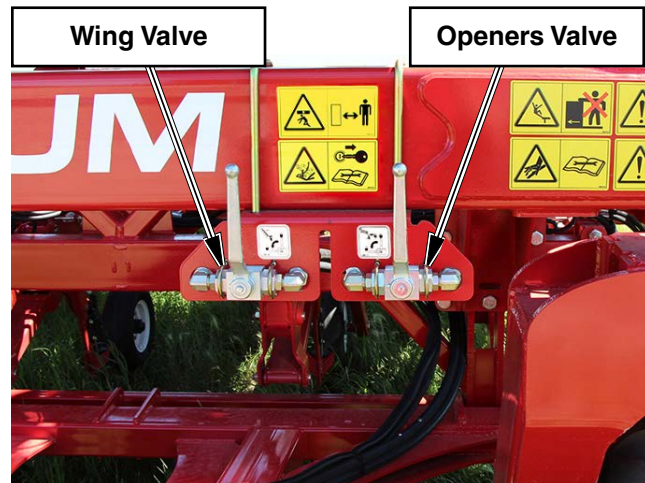

Warning: Crushing Hazard

To prevent serious injury or death:

- Stand Clear - openers move rapidly under hydraulic pressure.
- Before servicing hydraulics - Lower openers to ground and relieve pressure from hydraulic system.
- Ensure Opener Hydraulic System is disabled before working underneath machine.
 - Shut tractor off and remove key before servicing or adjusting depth.
 - Place “Openers” valve in locked position before adjusting depth or transporting.

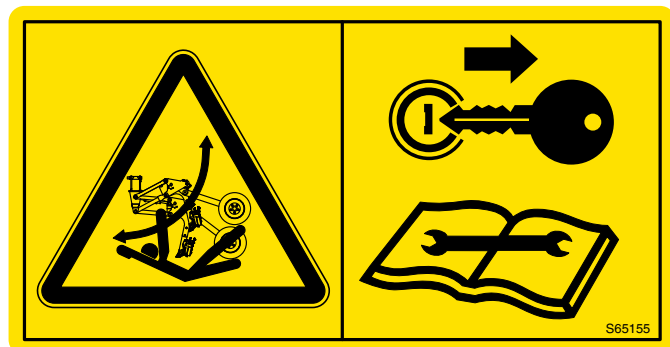

Depth Adjustment - Continued

- Remove lynch pin from 1/2" diameter depth pin.
- Remove depth pin.
- Rotate depth cam to desired lettered setting ("A" is the shallowest position). Each increment changes the depth a 1/4" (6.4 mm). A good starting point for depth settings would be setting "D".
- Reinstall 1/2" pin and lynch pin noting letter position before adjusting other openers.

Note: For ease of adjustment, adjust a few openers across the drill to confirm desired seeding depth before adjusting the remaining openers.

- Move the "Openers" ball valve to the unlocked position before using drill.

Depth Range Interval Change

- A shim in the normal operating position (produces depth range results similar to the C2).
- Removing the shim will make each position on the depth cam 1" (25.4 mm) deeper.
i.e. if the seeding depth is at 1" (25.4 mm) and the shim is removed the seeding depth would now be at 2" (50.8 mm) roughly.
- The depth cam remains the same i.e. going from A to B will change the depth by 1/4" (6.4 mm).

Important

Pneumatic Tires Only.

Keep opener tires air pressure at the listed specifications to achieve and maintain proper seed depth.

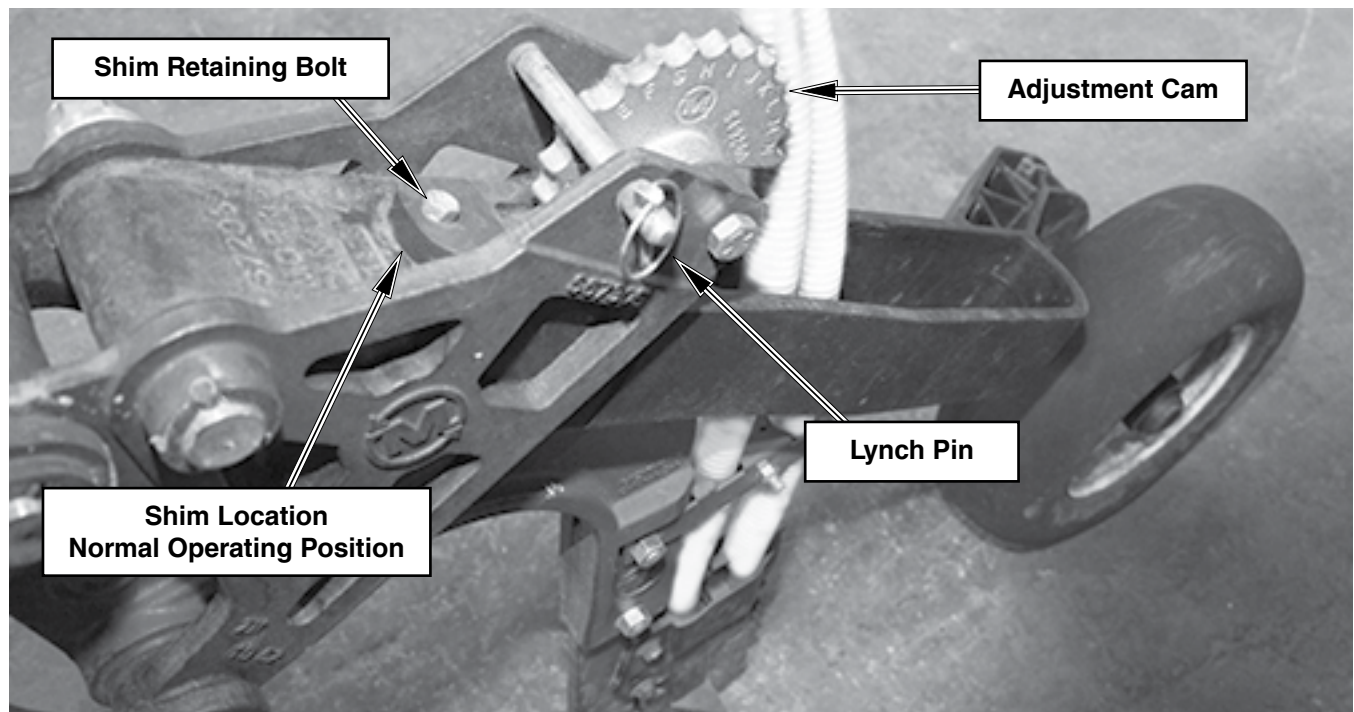

Operation

Work Switch

(Optional equipment)

The pressure work switch activates the Air Cart Metering system by the hydraulic pressure on the opener lift side. When the openers are raised the switch opens at a pre-set pressure turning off the Air Cart metering and when lowered the switch closes at the pre-set pressure to turn on the metering.

The pre-set Factory set point meets most operators' preference. If the turn ON and OFF time needs to be adjusted follow the procedure below:

- Remove cover from back of switch.
- Insert a 3/32" allen wrench into the adjustment screw opening. Turn the screw clockwise to increase the set point or counter clockwise to decrease.
 - Increasing set point will cause the metering system to **turn ON quicker**. This will also cause the metering system to turn OFF later.
 - Decreasing set point will cause the metering system to **turn ON later**. This will also cause the metering system to turn OFF quicker.

Important

Ensure metering clutch is turned OFF when moving unit to prevent damage to metering wheels in the event pressure switch is in ON position.

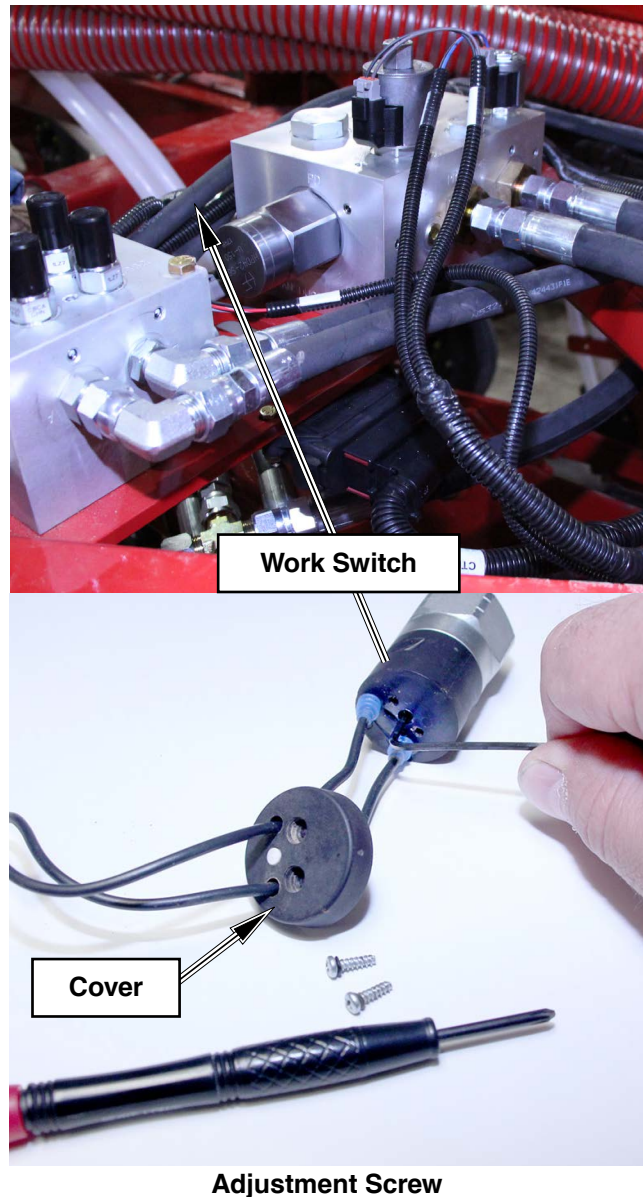

General Guidelines

The results obtained from the Morris QUANTUM Drill are directly related to the depth uniformity of the unit. Worn points, uneven tire pressures, and bent shanks must be avoided to obtain optimum field results.

- Operating depth should be uniform at all opener locations, when spot checking the implement in the field.
- Check openers running in tractor or air cart tracks and adjust depth accordingly.
- Repair or replace bent shanks. Bent shanks cause openers to work at uneven depths and can cause unnecessary ridging. See Maintenance Section.
- Keep tire pressure at the listed specifications to maintain proper level. See Maintenance Section.
- Have Air Drill moving forward before lowering into ground to avoid plugging openers.
- Avoid sharp turns. Turns sharp enough to cause the inside openers of the air drill to reverse direction are not recommended. This may cause the seed openers to plug.



TAKE SAFETY SERIOUSLY.

Do Not Take Needless Chances!

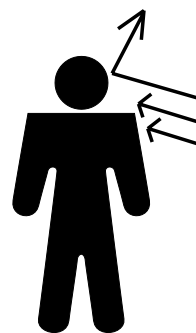

Caution

Care should be taken when working near the air cart while the fan is running. Product blowing out of the system could cause personal injury.



Operation

Quick Tips

Note: Read the Operator's Manual for detailed operating and adjustment instructions.

Shank Trip Force

Shank trip force (lbs) is calculated by dividing the display pressure by 1.6 (ex. 800 psi display pressure = 500 lbs shank trip force). Shank trip out pressure is generally set at the minimum pressure that keeps the shanks solid in the vertical position and prevents them from repeatedly "tripping out", while still providing adequate packing. Maximum recommended shank trip out pressure is 1200 psi.

Note: Operate system at the lowest system pressure that will keep shanks locked vertical during seeding and provide adequate packing pressure. Excessive hydraulic pressure may disturb rocks and damage carbides.



Packing Force

Packing force is proportional to shank trip out force and is roughly 1/3 of the shank trip force (ex. 500 lbs shank trip force would give approximately 167 lbs of packing force).

Hydraulic System

The Quantum Air Drill uses an active hydraulic system meaning that approximately 3-4 gpm will be consumed by the system during operation. A reducing/relieving valve (S2) sets the pressure value and is controlled from the cab. Operating pressure range is normally anywhere from 500 to 1200 psi depending on soil conditions, opener selection and ground speed. Opener pressure can be reduced on the go for soft spots or tilled areas in the field or increased for hard packed areas. Float position (equal pressure on both sides of opener cylinder) is also possible using the Topcon system and can be effective at walking the drill through low spots.

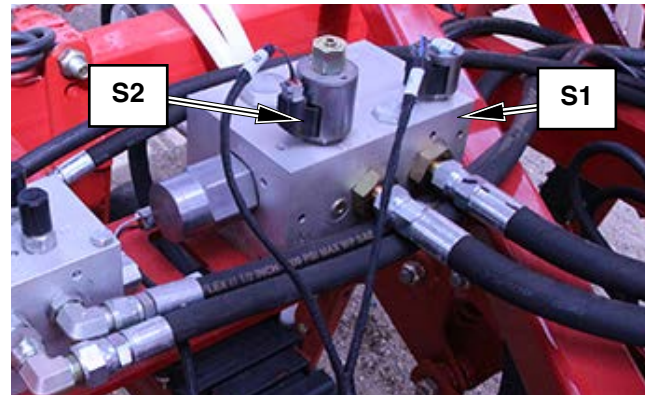

Lifting and Lowering the Openers

Openers will travel all the way up or all the way down to working position based on the controller selection; there is no middle operating position. Ensure the openers are fully lifted with the transport ball valve locked and the tractor hydraulics off for road transport.



Quick Tips - Continued

Setting the Seed Depth

Seed depth is measured from the packed soil surface to the seed. Set the seed depth on the drill by setting a few openers across the drill to different depths and seeding a test patch. Always seed the test patch at the same ground speed and opener pressure that you intend to maintain during regular seeding conditions. Then check the seed depth of these openers, pick the depth setting that you prefer, and set all openers to the desired letter setting on the depth adjustment cam. The openers perform best while seeding from 1/2" (13mm) to 1-1/2" (38 mm) seed depth, but each customer is responsible for choosing their own depth setting according to their preferences and experience. Each adjustment notch on the adjustment cam is 1/4" (6.4 mm) adjustment. Shallow depth settings can be consistently maintained with the QUANTUM Air Drill system.

Note: Be sure to check tractor and/or air cart tracks to see if the added soil compaction has affected the seed depth; the independent openers can be adjusted separately to compensate for wheel tracks.

Seeding Conditions

The QUANTUM Air Drill is meant to be used as a minimum to no-till seeding system and care should be taken when attempting to seed into loose or pre-worked soil conditions. Shallow seeding depth, reducing operating speed and operating pressure may help reduce soil throw and ridging in soft conditions.

Note: Soil throw onto adjacent seed rows also occurs on conventional air drills with gang style packers, but is less visible because the gang packers pack all rows simultaneously at the back of the drill.

Straw Management

Successful seeding starts at harvest. The height of the straw should not exceed the row spacing of the seeding unit. The combine should chop the straw and spread the straw and chaff evenly across the entire swath width. A heavy harrow may also be required to spread and break down the straw after the field has been harvested. If the straw height does exceed the row spacing a mower should be used to shorten the straw length.



IMPORTANT

The Paired Row Opener with the NH3 adapter is intended to allow the operator the flexibility to switch between granular fertilizer and NH3 without having to change openers. The opener is not intended to apply granular fertilizer and NH3 in the same operation. Excessive gassing off of the NH3 will occur in such an operation. Producers are still able to place starter fertilizer with the seed.

Morris Equipment shall have no obligation or liability of any kind on account of the end-user incorrectly using this opener.

Operation

Quick Tips - Continued

Air Drill Frame

The QUANTUM Air Drill frame is a simple slab frame system, designed to let the parallel link openers do the work of depth control and leveling during seeding. No leveling of the frame is required. During normal operation of the drill there will be very little weight on the rear tires of the frame. The rear tires may even leave the ground while traveling through sharp gullies; this is normal, and it will not affect the seed depth control of the openers. If the tires are lifted in the air consistently, optional weight kits can be applied to the depth beams near the rear axles.

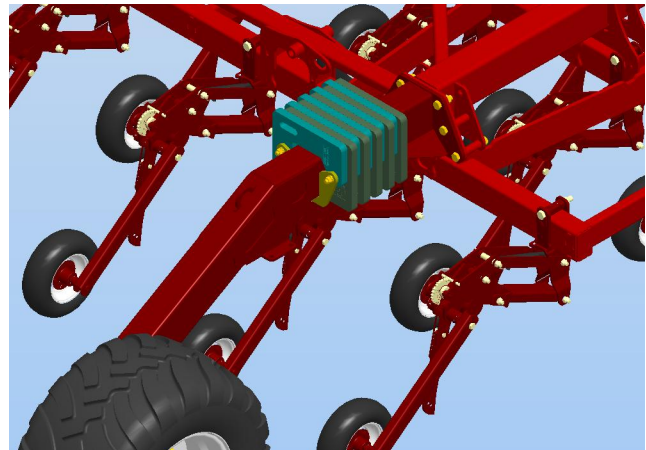

Weight Kit



Normal Frame Angle

Trouble Shooting Guide

***Note: Remove all pressure from hydraulic systems before attempting any service work on hydraulic components.**

Hydraulic system must be bled after it has been serviced (if any portion of the system has been opened to atmosphere) and also on initial start-up or if spongy or irregular trip operation is occurring. See “Bleeding Hydraulic System” in Maintenance Section.



Wing Lift Hydraulics

The wing lift hydraulic system is controlled by a parallel hydraulic system. A pressure compensated Flow Control Valve is used to control the flow of oil to the cylinders allowing both wings to fold and unfold simultaneously. A hydraulic circuit Shut Off valve is used to lock the hydraulic circuit and prevent any leak back, this ensures the wings remain in transport.

The Flow Control Valve is located on the main frame and there are no adjustments associated with the valve.

The Shut Off valve is located on the front wing lift truss for easy access.

To unfold the Air Drill, the oil flows to the Flow Control Valve, from there to the butt end of all the wing lift cylinders extending the shafts and lowering the wings. All cylinders must be fully extended to ensure correct operation of the machine.

Placing the unit into transport is the reverse of unfolding the unit. Oil is fed to the shaft end of the cylinders retracting the cylinders and lifting the wings into transport position.

Note: When raising or lowering wings, do so in one continuous motion until fully up or down. Do not stop flow part way allowing wings to fold on their own. This may disrupt the sequence of operation.

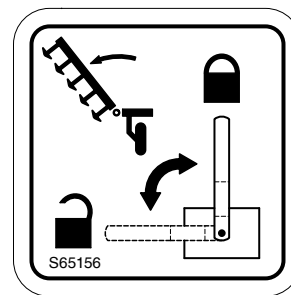
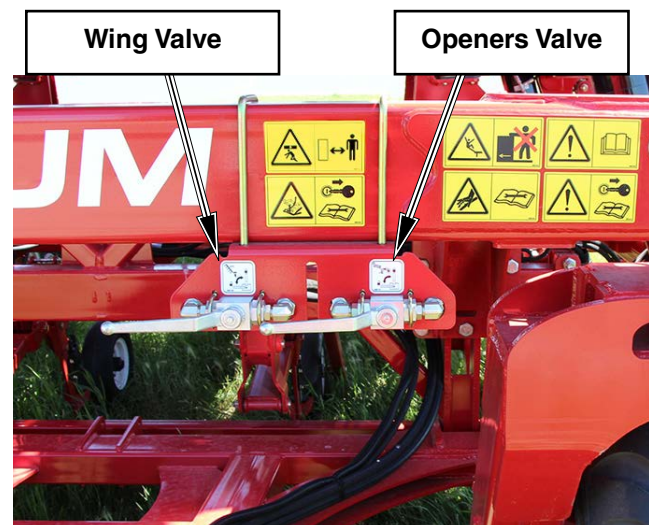

Operation

Wing Lift Hydraulics - Continued

Three Frame Models

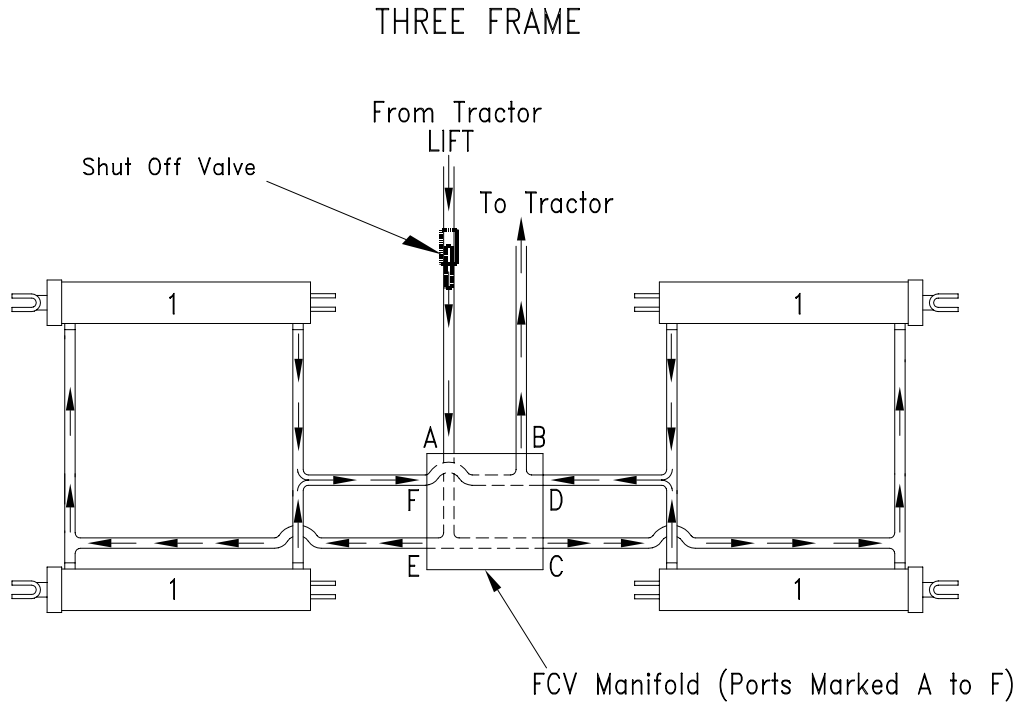

Five Frame Models

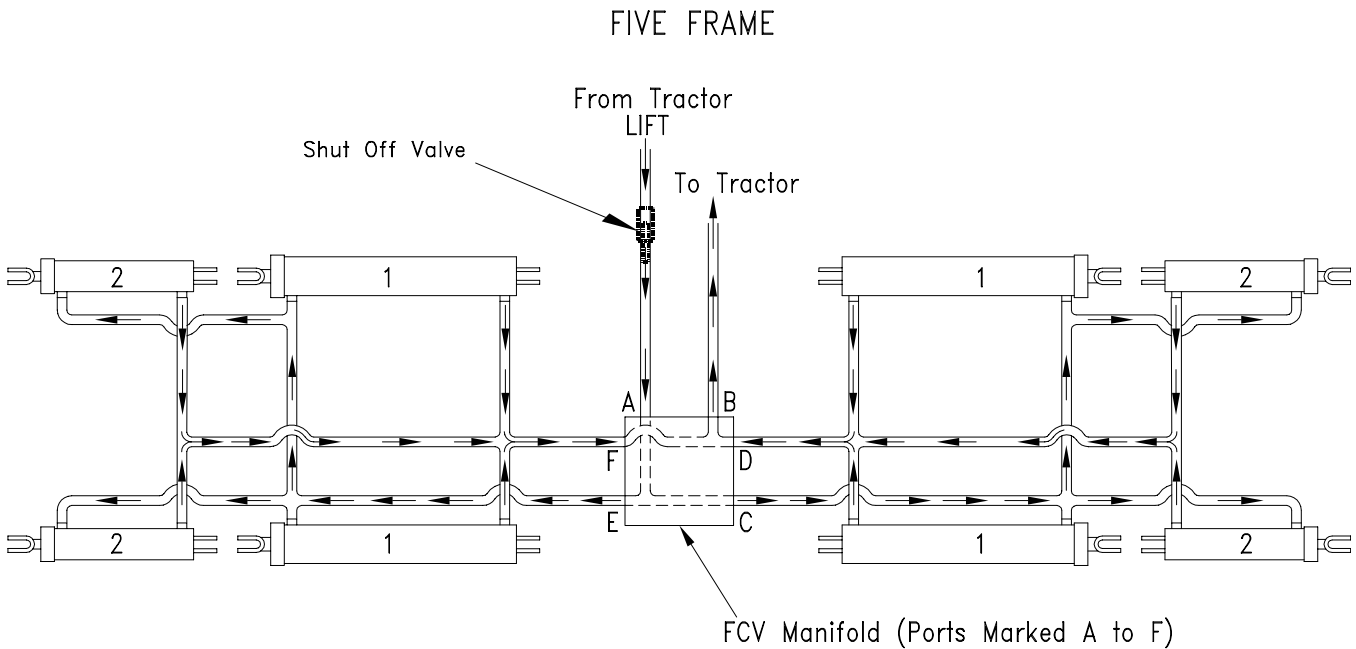

Opener Hydraulics

The QUANTUM uses an active hydraulic control system.

This means the tractor's hydraulic circuit to the QUANTUM openers are **permanently engaged into the working position** through manifold block (S64940) which controls the Lift-Lower and packing pressure functions via a controller and an in-cab display.

The controller and display provide the user the ability to adjust the opener downforce packing pressure on the go from inside the cab while applying product.

The following is the oil flow for both operating types and can be used for problem diagnosis.

To lower

- Pressing Opener “DOWN” button on the controller will lower the openers all the way down and lock them into working position by shifting solenoid valve “S1” which actuates pilot directional valve “PD”; “PD” valve in the diagram will be at its default position of flow straight through.

To raise

- Pressing Opener “UP” button on the controller will lift the openers fully up by shifting solenoid valve “S1” which actuates pilot directional valve “PD”; “PD” valve in the diagram will be shifted to cross the flow over (arrows crossed symbol).

Pressure Setting:

- Pressure can be adjusted on the go from the tractor cab using the display.
- Pressing the Pressure “INC” button on the display will increase the pressure by shifting proportional reducing/relieving valve S2 in the block; each press of the arrow will lift the pressure value by approximately 25 psi (172 kPa).
- Pressing the Pressure “DEC” button on the display will decrease the pressure by shifting proportional reducing/relieving valve S2 in the block; each press of the arrow will drop the pressure value by approximately 25 psi (172 kPa).
- The system will remember the last pressure setting that it operated at and revert to that at next start up.

Trouble Shooting

The opener valve (S1) has two states; **ON** (opener UP) and **OFF** (opener DOWN). When the opener valve is on/UP, the output is set to 3000mA (default value). When the opener is off/DOWN, the output is set to 0mA. These signals can be measure with a multi-meter directly at the valve connection. Just pull the plug out of the coil and measure the amperage across the two pins of the wire harness connector. Pin 1 of the S1 wire harness connector is connected to the controller output and pin 2 is connected to ground. **Check these values without any hydraulic power.**

The pressure reducing valve (S2) output is dependent on the state of the opener valve. If the opener is on/UP, the output to the S2 valve is 1050mA, or roughly 87.5% of the max value of that valve (approximately 1750psi). When the opener is off/DOWN, the output to the S2 valve is whatever value has been set by the user via the display. As it is now, this value can be anywhere from 350mA to 1200mA.

S1 and S2 are both current-controlled PWM outputs. Make sure to measure amperage and not voltage.

Comm Icon: Cable is not connected correctly, Cable is not terminated correctly, incorrect firmware loaded / Board Revision.

Operation

LOWER OPENERS

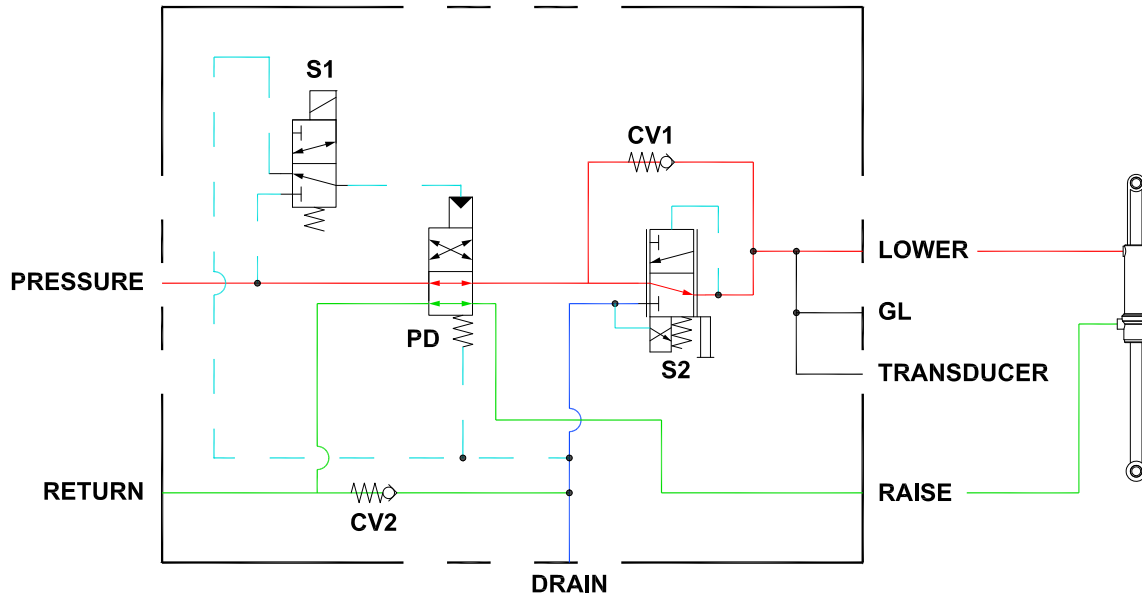

PRESSURE

RETURN

CASE DRAIN

RAISE OPENERS

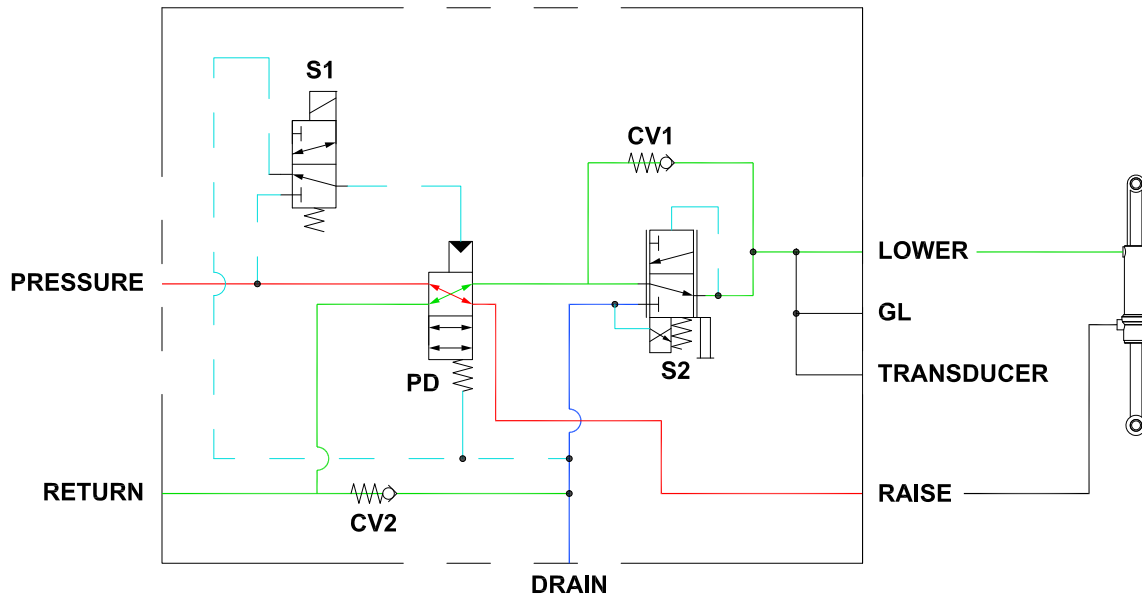

PRESSURE

RETURN

CASE DRAIN

Section 6: Maintenance

Section Contents

General	6-2
Safety	6-2
Tighten Bolts.....	6-3
Tires.....	6-3
Lubrication	6-4
Opener Maintenance	6-5
Bushing Replacement	6-5
Cylinder Replacement.....	6-5
Opener Body Assembly.....	6-6
Opener Assembly.....	6-8
Shank Replacement.....	6-15
Bleeding Hydraulic System.....	6-16
Hydraulic System Trouble Shooting	6-17
Hydraulics	6-18
Wheel Bearings	6-19
Implement Hub.....	6-19
Opener Hub	6-20
Pack Control Hub	6-21
Packer Wheel Assemblies	6-22

Maintenance

CAUTION



BE ALERT

SAFETY FIRST

**REFER TO SECTION 1 AND REVIEW ALL
SAFETY RECOMMENDATIONS.**

General

This section deals with two goals, maximum life and dependable operation. Adopt a regular maintenance and lubrication program. Care and sufficient lubrication is the best insurance against delays.

Safety

- Always shut off the tractor and remove key before dismounting.
- Guard against hydraulic high pressure leaks with hand and face protection.
- Never work under the implement unless it is in the down position or transport lock pins are in place and secured with hair pins. Do not depend on the hydraulic system to support the frame.
- Always wear safety goggles, breathing apparatus and gloves when working on seeder filled with chemical. Follow manufactures recommended safety procedures when working with chemicals or treated seeds.
- Do not feed left over treated seed to livestock, treated seed is poisonous and may cause harm to persons or livestock.





Tighten Bolts

- Before operating the machine.
- After the first two hours of operation.
- Check tightness periodically thereafter.
- Use Bolt Torque Chart for correct values on various bolts.
- Note dashes on hex heads to determine correct grade.

Note: DO NOT use the values in the Bolt Torque Chart if a different torque value or tightening procedure is given for a specific application.

- Fasteners should be replaced with the same or higher grade. If higher grade is used, only tighten to the strength of the original.

Bolt Torque Chart				
Grade 5 Bolt Marking 		Bolt Size	Grade 8 Bolt Marking 	
Nm	lb-ft		lb-ft	Nm
11	8	1/4	12	16
23	17	5/16	24	33
41	30	3/8	45	61
68	50	7/16	70	95
102	75	1/2	105	142
149	110	9/16	155	210
203	150	5/8	210	285
366	270	3/4	375	508
536	395	7/8	610	827
800	590	1	910	1234
1150	850	1-1/8	1350	1850
1650	1200	1-1/4	1950	2600
2150	1550	1-3/8	2550	3400
2850	2100	1-1/2	3350	4550

Tires

- Inspect tires and wheels daily for tread wear, side wall abrasions, damaged rims or missing lug bolts and nuts. Replace if necessary.
- Tighten wheel bolts - refer to Bolt Torque Chart.
- Check tire pressure daily, when tires are cold.
- Correct tire pressure is important.
- Do not inflate tire above the recommended pressure.

Tire Specifications		
SIZE	LOAD RANGE	PRESSURE
4.80-8 NHS	4 ply rating	12 psi (83 kPa)
445/50R22.5	167D	38 psi (262 kPa)
600/50R22.5	165A8	38 psi (262 kPa)
650/55R26.5	169D/180 A8	50 psi (345 kPa)



Caution

Tire replacement should be done by trained personnel using the proper equipment.

Wheel Bolt Torque	
SIZE	Torque
1/2	75 lb-ft (102 Nm)
M22	400 lb-ft (542 Nm)

Maintenance

Lubrication

Greasing pivot points prevents wear and helps restrict dirt from entering. However, once dirt does enter a bearing, it combines with the lubricant and becomes an abrasive grinding paste, more destructive than grit alone.

- Apply new lubricant frequently during operation to flush out old contaminated lubricant.
- Use a good grade of **lithium based grease**.
- Use a good grade of machine oil.
- Clean grease fittings and lubricator gun before applying lubricant.

Refer to the photos for grease fitting locations.

1. Wheel Hubs

- Grease every 50 hours or seasonally, whichever occurs first.

2. Gauge Wheel Castor Pivot

- Grease every 50 hours.

3. Packer Wheel Hubs

- Grease every 50 hours or seasonally, whichever occurs first.

4. Hitch Clevis Ball

- Grease every 10 hours.

5. Hitch Pivot Pins

- Grease every 100 hours.

6. Hinge Pins

- Grease every 100 hours.

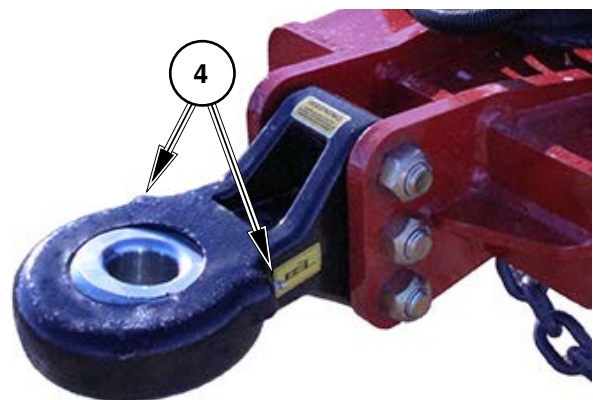

Opener Maintenance

Bushing Replacement

In the event the pivot pin bushings need replacing, use the following procedure.

- **Relieve all pressure** from the opener circuit by placing the tractor remote in “float” position.
- Shut tractor engine off and ensure park brake is engaged before proceeding.
- Place “Openers” ball valve into locked position to prevent accidental oil flow to openers.
- Once the pressure is off of the opener circuit, the opener can be disassembled as illustrated in diagram on the following page.

Reverse the above procedure to reassemble trip.

Note: Bleed air from hydraulic circuit before using unit. Refer to “Bleeding Hydraulic System” for details.



Cylinder Replacement

In the event the opener cylinder needs repair or replacing, use the following procedure.

- **Relieve all pressure** from the opener circuit by placing the tractor remote in “float” position.
- Shut tractor engine off and ensure park brake is engaged before proceeding.
- Place “Openers” ball valve into locked position to prevent accidental oil flow to openers.
- Once the pressure is off of the opener circuit, disconnect hydraulic hoses from opener cylinder.
- Refer to diagram on following page to remove the pins from the opener cylinder.
- Remove the cylinder. Repair or replace cylinder as necessary.

Reverse the above procedure to reassemble trip.

Note: Bleed air from hydraulic circuit before using unit. Refer to “Bleeding Hydraulic System” for details.

 Warning

HIGH-PRESSURE FLUID HAZARD To prevent serious injury or death: <ul style="list-style-type: none">• Relieve pressure on hydraulic system before servicing or disconnecting hoses.• Wear proper hand and eye protection when searching for leaks. Use wood or cardboard instead of hands.• Keep all components in good repair.

 Warning
CRUSHING HAZARD To prevent serious injury or death: <ul style="list-style-type: none">• Stand clear - openers move rapidly under hydraulic pressure.• Place valve in service position.• Relieve pressure on hydraulic system before servicing.• Lower openers to ground before adjusting depth.• Shut tractor off and remove key.

Maintenance

Opener Maintenance - Continued

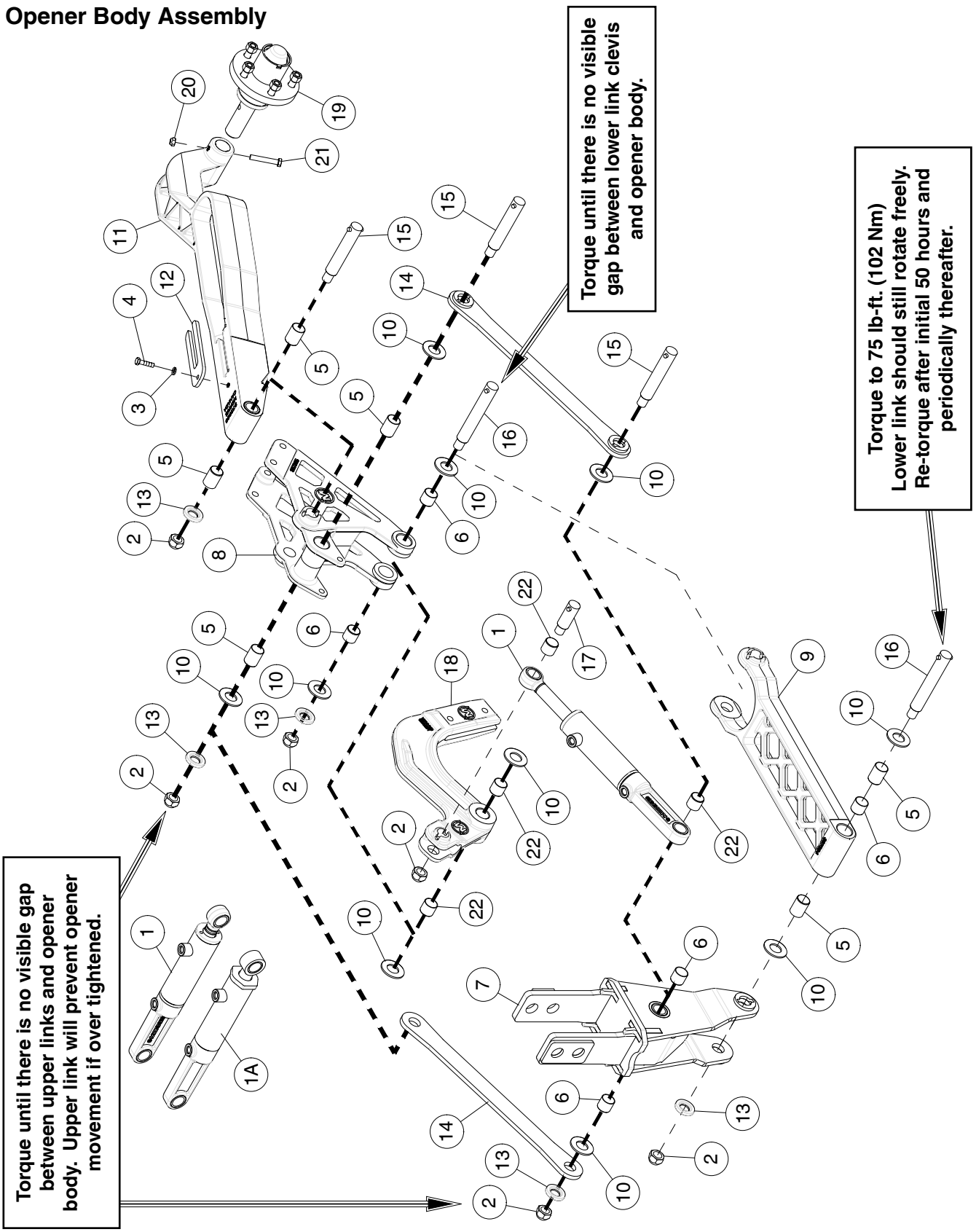
Opener Body Assembly



Opener Maintenance - Continued

Opener Body Assembly

Item	Part No.	Description	Qty
1	C72090	Cylinder - 1 3/4 Bore x 4 Stroke - (Includes Item 22 Qty of 2) - 2023 (Seal Kit C72720)..	1
1A	C68272	Cylinder - 1 3/4 Bore x 4 Stroke - (Includes Item 22 Qty of 2) (Seal Kit C71900)	
2	D-5275	Locknut - 3/4 nylon insert.....	6
3	W-522	Lock Washer - 5/16	1
4	F-1767	Hex Bolt - 5/16 x 3/4 Lg.....	1
5	S67549	Q2 Bushing - 1 ID x 1 1/4 OD x 1 1/2 Lg Nominal size.....	6
6	S59806	Q2 Bushing - 1 ID x 1 1/4 OD x 1 Lg Nominal size.....	5
7	S67303	Mounting Bracket - Cast - (Includes Item 22 Qty of 2) - 2023.....	1
	S69360	Mounting Bracket - Welded - (Includes Item 6 Qty of 2).....	1
8	S67305	Opener Body - (Includes Item 5 Qty of 2 and Item 6 Qty 2).....	1
9	S67304	Bottom Link - (Includes Item 5 Qty of 2 and Item 6 Qty 1)	1
10	S69398	Washer - 1 1/32 ID x 2 OD x 1/8.....	10
11	S72060	Packer Arm - Right - (Includes Item 5 Qty of 2) - Shown	1
	S72065	Packer Arm - Left - (Includes Item 5 Qty of 2)	1
12	S66251	Shim - Depth Adjustment - 1/4 Thick.....	1
13	S72061	Washer - Step - Machined - 0.800 ID x 1.063 ID x 1 9/16 OD x 0.266 Thick.....	5
14	S65009	Top Link.....	2
15	S69573	Pin - Chrome - 1 Dia x 5 1/16 UL (Includes S73071 Roll Pin).....	3
16	S69574	Pin - Chrome - 1 Dia x 5 23/32 UL (Includes S73071 Roll Pin)	2
17	S69598	Pin - Chrome - 1 Dia x 1 29/32 UL (Includes S73071 Roll Pin)	1
18	S67613	Cast Shankholder - (Includes Item 22 Qty of 2)	1
19	S48850	Spindle Hub Assembly	1
20	M-3388	Locknut - 3/8 Unitorque.....	1
21	W-480	Hex Bolt - 3/8 x 2 1/2 Lg.....	1
22	S72046	EWS Bushing - 1 ID x 1 1/4 OD x 1 Lg Nominal size	4
	S73284	Quantum Cast Row Unit Rebuild Kit (Includes Items 2, 5, 6, 10, 13, 15, 16, 17, 22)	

Note: Openers should drop to the ground under their own weight, when the tractor remote is placed into float position relieving oil pressure.

If it requires pressure to push an opener down to the ground during this procedure, one or more of the pivot bolts are over tightened.

Check and adjust pivot bolts as required.

Important

Remove all pressure from hydraulic systems before attempting any service work on hydraulic components.

Hydraulic system must be bled after it has been serviced (if any portion of the system has been opened to atmosphere) and also on initial start-up or if spongy or irregular trip operation is occurring.

Maintenance

Opener Maintenance - Continued

Opener Assembly

Important
Torque 1" Locknut (3) to 400 ft. lbs. (542 Nm)
Re-torque locknut (3) after initial 50 hours
and periodically thereafter.

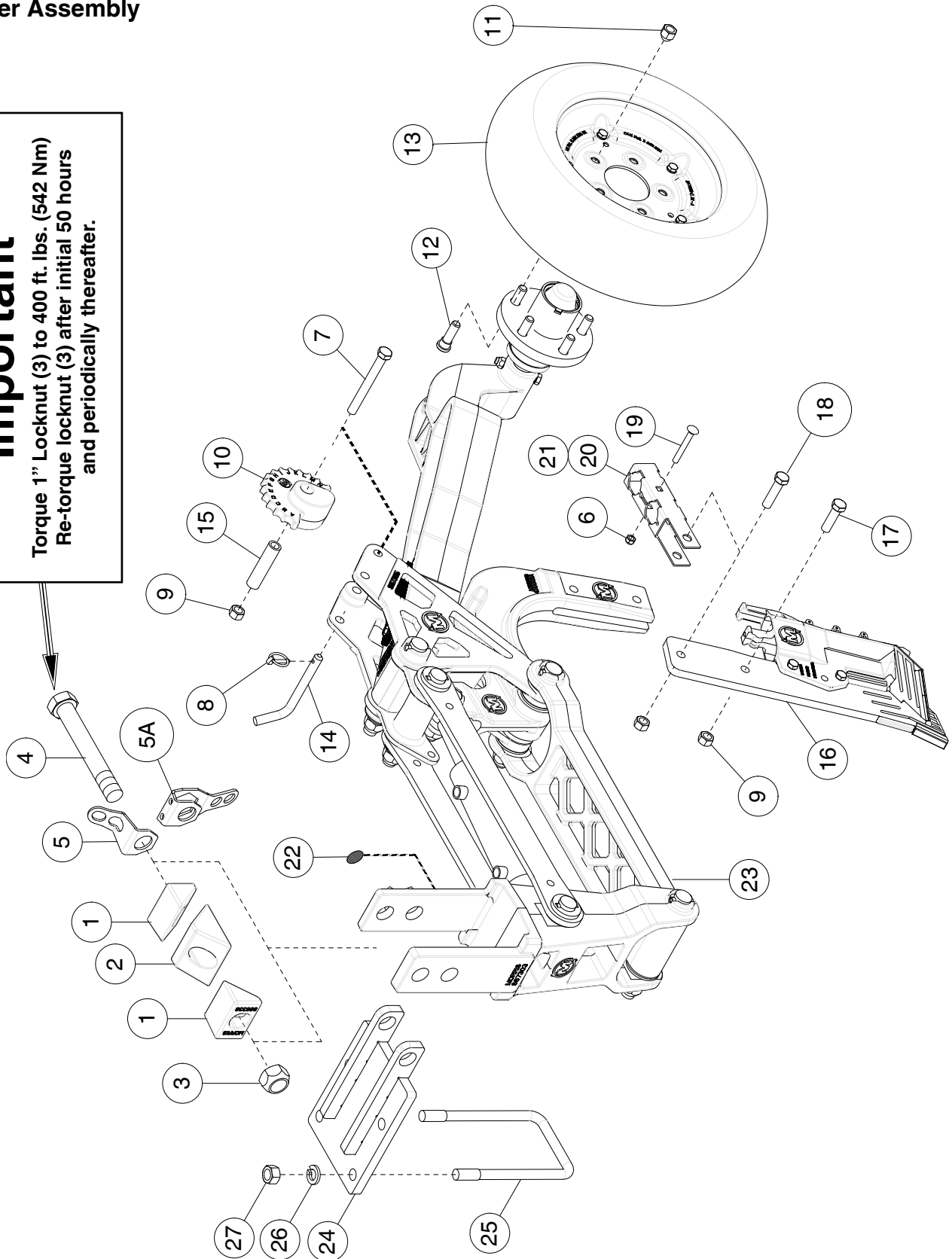

Opener Maintenance - Continued

Opener Assembly

Item	Part No.	Description	Qty
1	S66338	Outer Wedge - Cast Alloy	2
2	S66337	Centre Wedge - Cast.....	1
3	D-5274	Lock Nut - 1 Unitorque	1
4	S42952	Hex Bolt - 1 x 6 5/8 Lg.....	1
5	S66245	Hose Holder - Opener.....	1
5A	S67170	Hose Holder - Opener - Low Profile - 4 per machine	
6	D-5272	Lock Nut - 5/16 Unitorque	1
7	S66403	Hex Bolt - 1/2 x 4 1/2 Lg - GR.8.....	1
8	S42294	Lynch Pin - 3/16 Dia x 1-3/8 Lg	1
9	S47110	Hex Nut - 1/2 Center Lock.....	3
10	S49260	Depth Cam - Cast	1
11	S50246	Tapered Wheel Nut - 1/2-20UNF.....	5
12	S50247	Press-In Wheel Stud - 1/2 - 20UNF.....	5
13	*****	See "Packer Wheel Assemblies".....	1
14	S65061	Depth Pin - 1/2 Dia.....	1
15	S67944	Bushing - 0.510 ID x 0.750 OD x 1 31/32 Lg	1
16	*****	Shank Assembly	
17	W-487	Hex Bolt - 1/2 x 1 3/4 Lg.....	1
18	S51464	Hex Bolt - 1/2 x 2 Lg - GR 8 (Hose Holder Replacement Bolt)	1
19	S51466	Carriage Bolt - 5/16 x 2 Lg	1
20	S69305	Hose Holder	1
21	S72297	Hose Holder Kit - Contains Items 6, 9, 18, 19 & 20.....	1
22	S66171	Openers Number Decal - 1 per machine	
		(1 4 7 10 13 16 19 22 25 28 31 34 37 40 43 46 49 52 55 58 61 64 67 70 73 76 79 82 85 88)	
		(2 5 8 11 14 17 20 23 26 29 32 35 38 41 44 47 50 53 56 59 62 65 68 71 74 77 80 83 86 89)	
		(3 6 9 12 15 18 21 24 27 30 33 36 39 42 45 48 51 54 57 60 63 66 69 72 75 78 81 84 87 90)	
23	S72302	Row Unit - Right (Includes items 7, 8, 9, 10, 11, 12, 14, 15) - Shown	1
	S72303	Row Unit - Left (Includes items 7, 8, 9, 10, 11, 12, 14, 15)	
	S71846	25cm Offset Spacing Kit (Includes items 24, 25 and 26) (Kit is used on inner wing - 2 kits required per drill)	
24	S71726	Offset Row Unit Mount - 25cm Spacing	
25	S39649	U-Bolt - 5/8 x 4 x 7 3/4 UL.....	2
26	W-526	Lockwasher - 5/8.....	4
27	W-517	Hex Nut - 5/8.....	4

Important

Remove all pressure from hydraulic systems before attempting any service work on hydraulic components.

Hydraulic system must be bled after it has been serviced (if any portion of the system has been opened to atmosphere) and also on initial start-up or if spongy or irregular trip operation is occurring.

Maintenance

Opener Maintenance - Continued

Opener Assembly - Continued

Single Shoot Boot

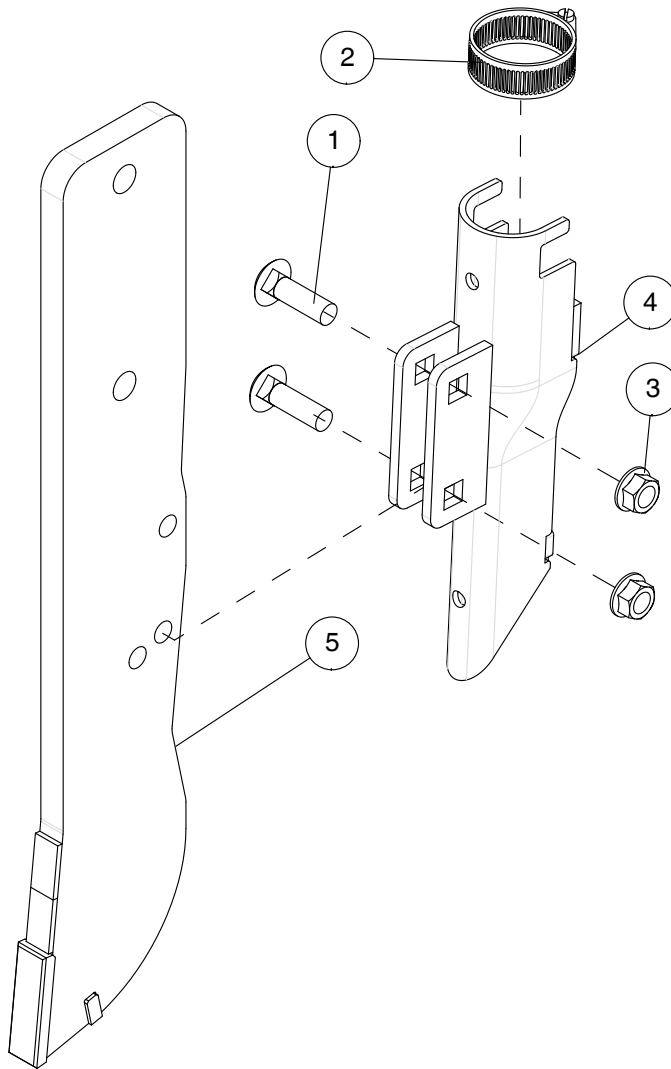

Item	Part No.	Description	Qty
1	D-5260	Carriage Bolt - 3/8 x 1-1/4 Lg	2
2	N11470	Hose Clamp	1
3	S27987	Center Lock Flange Lock Nut - 3/8	2
4	S42865	Single Shoot Boot	1
5	S72310	Forged Shank.....	1
	S72325	Forged Single Shoot Assembly - (Includes Items 1, 3, 4 and 5)	

Opener Maintenance - Continued

Opener Assembly - Continued

Single Shoot Boot - 3" Spread

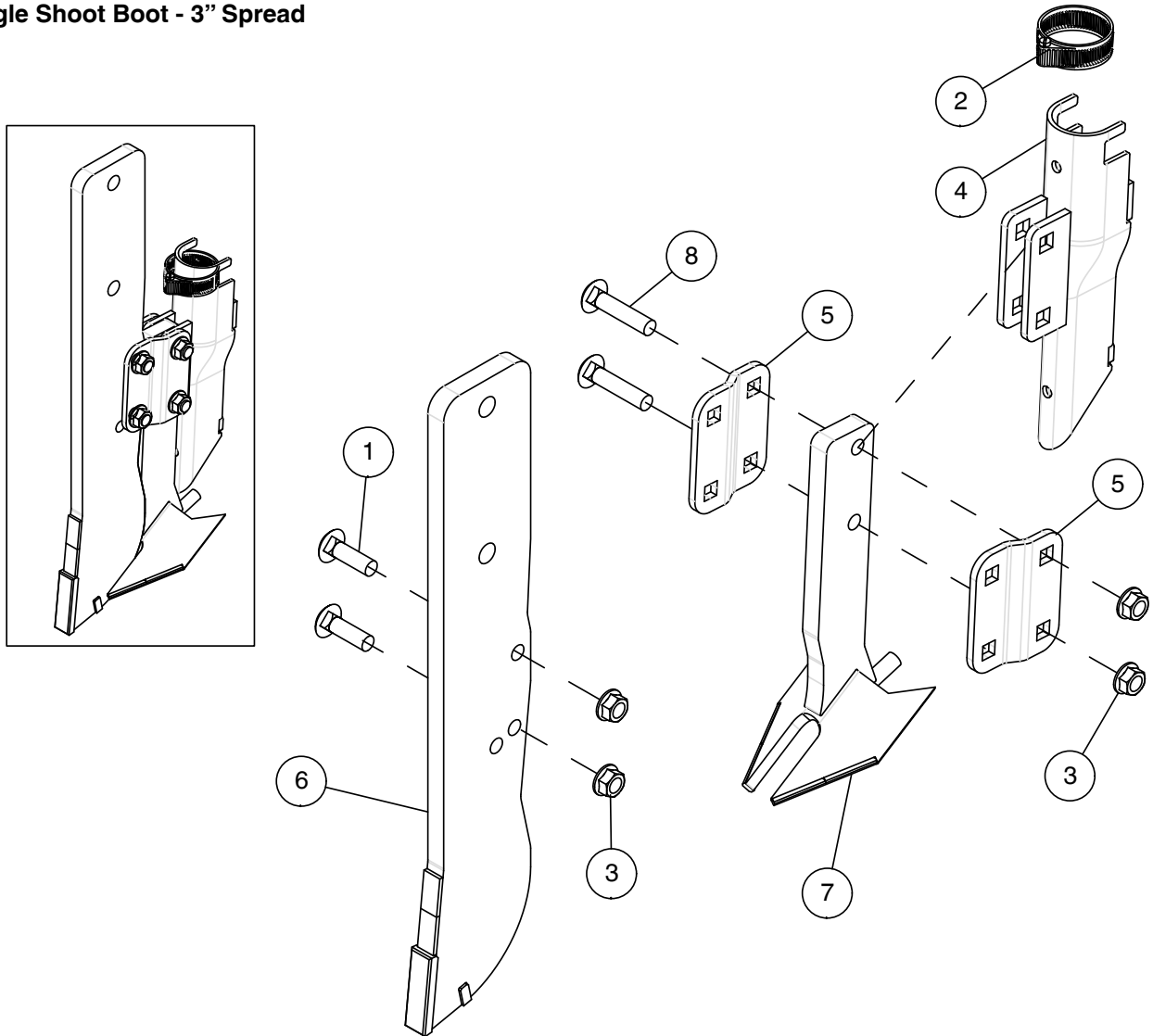

Item	Part No.	Description	Qty
1	D-5260	Carriage Bolt - 3/8 x 1-1/4 Lg	2
2	N11470	Hose Clamp	1
3	S27987	Center Lock Flange Lock Nut - 3/8	4
4	S42865	Single Shoot Boot	1
5	S45269	Mounting Plate	2
6	S72310	Forged Shank.....	1
7	S47337	3" Wear Shovel	1
8	S31980	Carriage Bolt - 3/8 x 1-3/4 Lg	2

Maintenance

Opener Maintenance - Continued

Opener Assembly - Continued

IP Left Side Band Kit

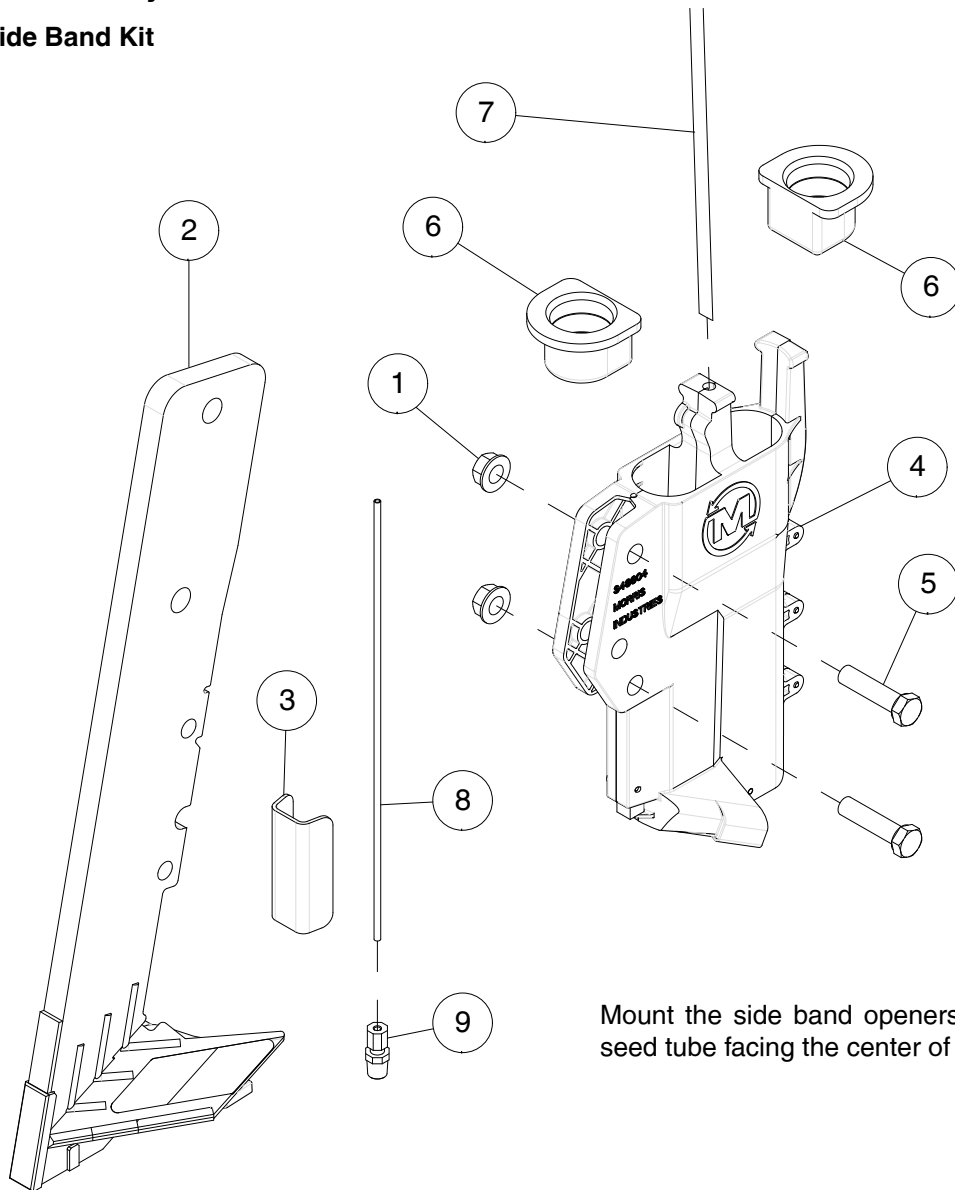

Mount the side band openers with the deflector and seed tube facing the center of the QUANTUM Air Drill.

Item	Part No.	Description	Qty
1	S27987	Lock Nut - 3/8 Flange W/Center Lock	2
2	S72309	Forged Shank - Sideband Left LD	1
3	S65074	Wear Guard - Claded	1
4	S56482	IP (Injected Polymer) Left Sideband Seed Boot	1
5	W-477	Hex Bolt - 3/8 x 1 1/2 Lg.	2
6	S47076	Secondary Hose Grommet	2
7	*****	Liquid Tube - 1/4 OD - See Liquid Kit Supplier for Tube	1
8	*****	Injector Tube - 1/8 OD - See NH3 Kit Supplier for Tube	1
9	S48814	Compression Fitting - 1/8 x 1/8	1
	S72324	Forged Sideband Boot Kit - Left IP - LD (Contains Items 1, 2, 3, 4 & 5)	1

Opener Maintenance - Continued

Opener Assembly - Continued

IP Right Side Band Kit

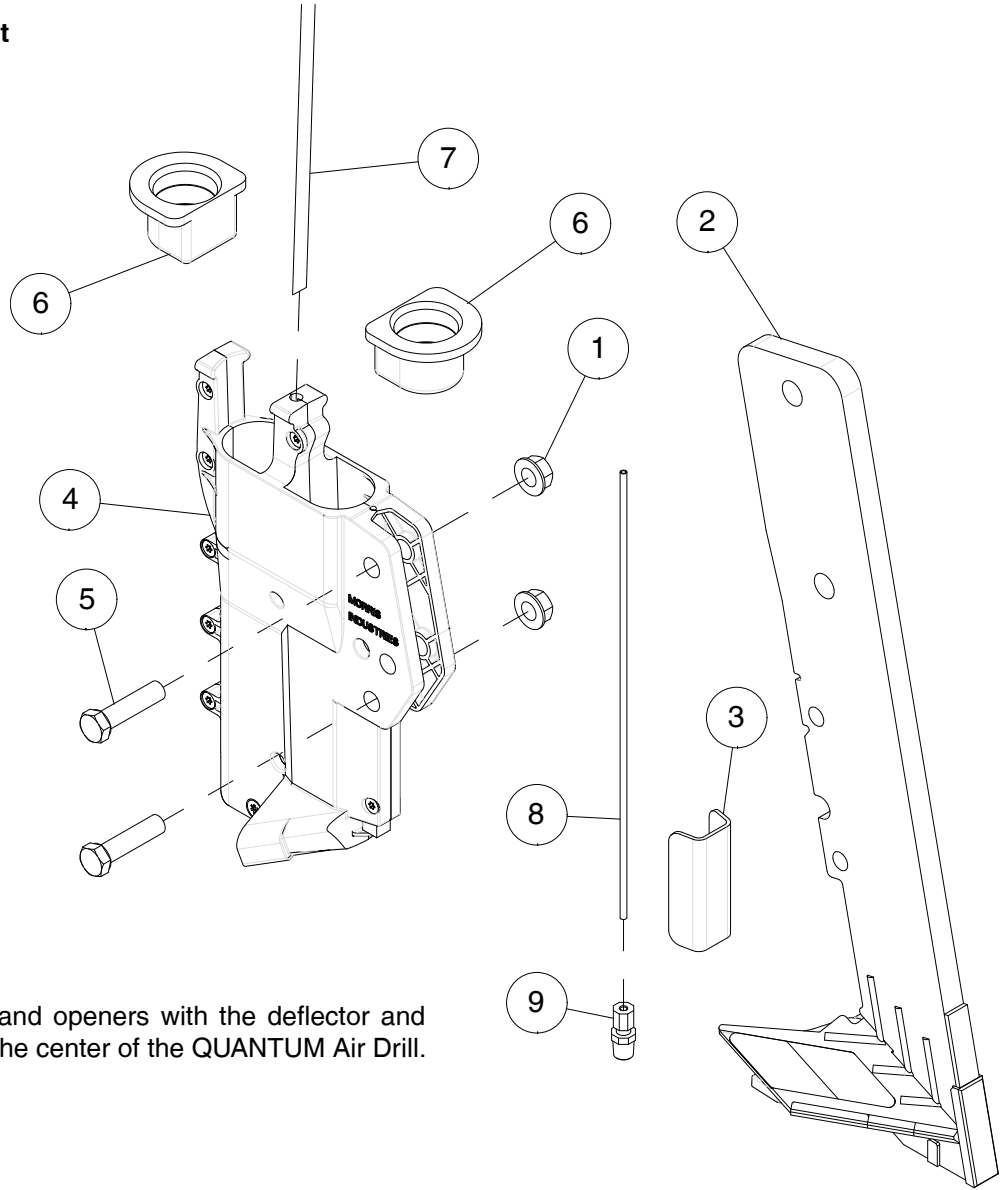

Mount the side band openers with the deflector and seed tube facing the center of the QUANTUM Air Drill.

Item	Part No.	Description	Qty
1	S27987	Lock Nut - 3/8 Flange W/Center Lock	2
2	S72308	Forged Shank - Sideband Right LD	1
3	S65074	Wear Guard - Claded	1
4	S56483	IP (Injected Polymer) Right Sideband Seed Boot	1
5	W-477	Hex Bolt - 3/8 x 1 1/2 Lg.....	2
6	S47076	Secondary Hose Grommet	2
7	*****	Liquid Tube - 1/4 OD - See Liquid Kit Supplier for Tube.....	1
8	*****	Injector Tube - 1/8 OD - See NH3 Kit Supplier for Tube	1
9	S48814	Compression Fitting - 1/8 x 1/8	1
	S72323	Forged Sideband Boot Kit - Right IP - LD- (Contains Items 1, 2, 3, 4 & 5)	1

Maintenance

Opener Maintenance - Continued

Opener Assembly - Continued

IP Paired Row Kit

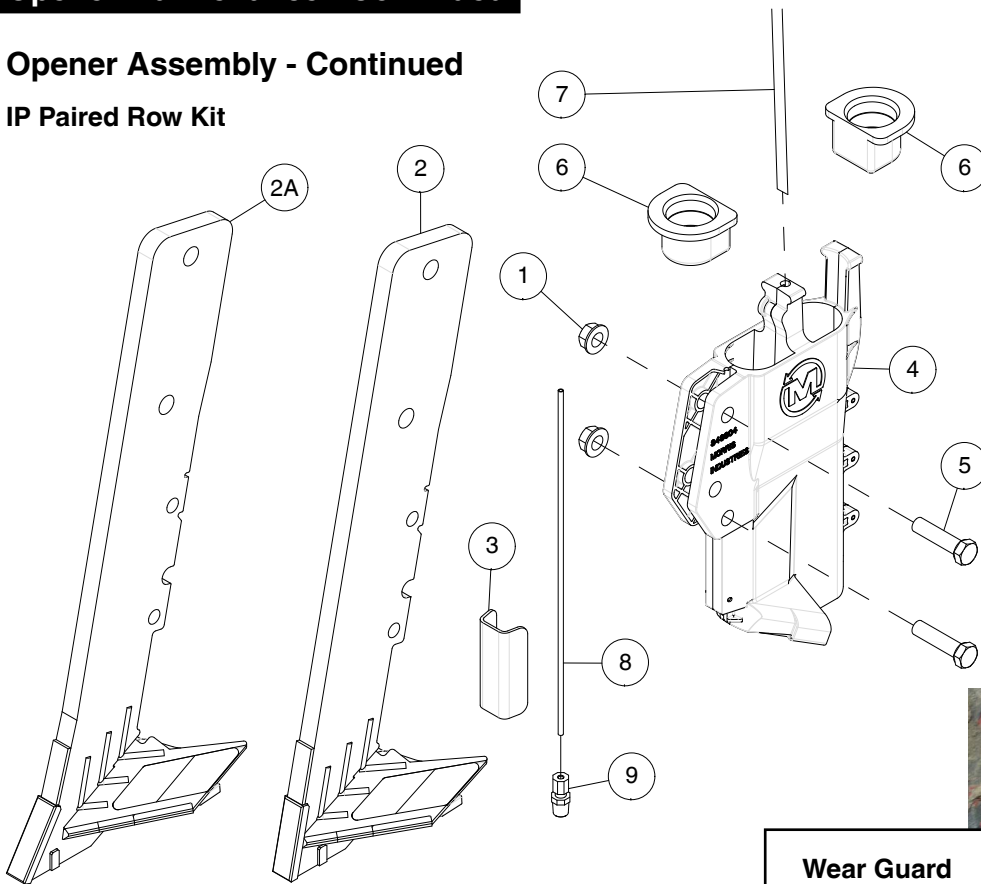

Important

Check Wear Guards regularly and replaced before the IP Boot is damaged.

Abbreviations:

IP - Injected Polymer
LD - Low Disturbance
HP - High Penetration



Item	Part No.	Description	Qty
1	S27987	Lock Nut - 3/8 Flange W/Center Lock	2
2	S72185	Forged Shank - Paired Row LD	1
2A	S72306	Forged Shank - Paired Row HP	1
3	S65074	Wear Guard - Claded	1
4	S56485	IP Paired Row Seed Boot.....	1
5	W-477	Hex Bolt - 3/8 x 1 1/2 Lg.....	2
6	S47076	Secondary Hose Grommet	2
7	*****	Liquid Tube - 1/4 OD - See Liquid Kit Supplier for Tube	1
8	*****	Injector Tube - 1/8 OD - See NH3 Kit Supplier for Tube	1
9	S48814	Compression Fitting - 1/8 x 1/8	1
	S72321	Kit: Forged Paired Row IP - LD (Contains Items 1, 2, 3, 4 & 5)	
	S72322	Kit: Forged Paired Row IP - HP (Contains Items 1, 2A, 3, 4 & 5)	

Opener Maintenance - Continued

Shank Replacement

In the event a shank needs replacing, use the following procedure.

- **Relieve all pressure** from the opener circuit by placing the tractor remote in “float” position.
- Shut tractor engine off and ensure park brake is engaged before proceeding.
- Place “Openers” ball valve into locked position to prevent accidental oil flow to openers.
- Once the pressure is off of the opener circuit, remove retaining bolts from shank holder. See diagram on page 6-8.
- Remove shank from shank holder.
- Remove opener from shank.
- Reverse above procedure to reassemble.

Warning: Crushing Hazard

To prevent serious injury or death:

- Stand Clear - openers move rapidly under hydraulic pressure.
- Before servicing hydraulics - Lower openers to ground and relieve pressure from hydraulic system.
- Shut tractor off and remove key before servicing or adjusting depth.
- Place “Openers” valve in locked position before adjusting depth or servicing.

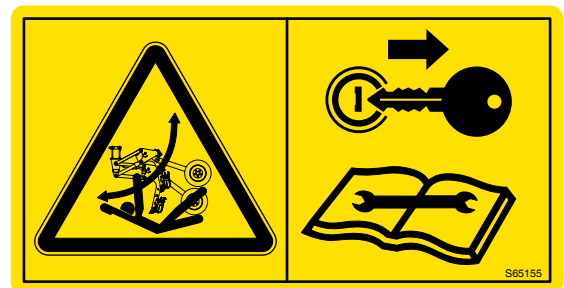

Maintenance

Opener Maintenance - Continued

Bleeding Hydraulic System

If hydraulic system has been serviced air will need to be bleed out of system as follows:

To bleed hydraulic system of air:

- Controller / X35 must be turned OFF.
- Lift openers up and lock tractor remote in lift position.
- With tractor hydraulics operating, open bleed-off ball valves on end of drill wings.
- Allow oil to cycle for several minutes then change direction of tractor remote to lower openers and cycle for several more minutes.
- Close bleed-off ball valves and lift openers up.
- Repeat above procedure for a second time.
- Close bleed-off ball valves and lift openers up.
- Lock "Openers" valve and check to see that openers stay firmly in position.
- If openers are spongy repeat procedure until air is gone.

Warning



HIGH-PRESSURE FLUID HAZARD

To prevent serious injury or death:

- Relieve pressure on hydraulic system before servicing or disconnecting hoses.
- Wear proper hand and eye protection when searching for leaks. Use wood or cardboard instead of hands.
- Keep all components in good repair.

Important

Remove all pressure from hydraulic systems before attempting any service work on hydraulic components.

Hydraulic system must be bled after it has been serviced (if any portion of the system has been opened to atmosphere).

And also on initial start-up or if spongy or irregular trip operation is occurring.

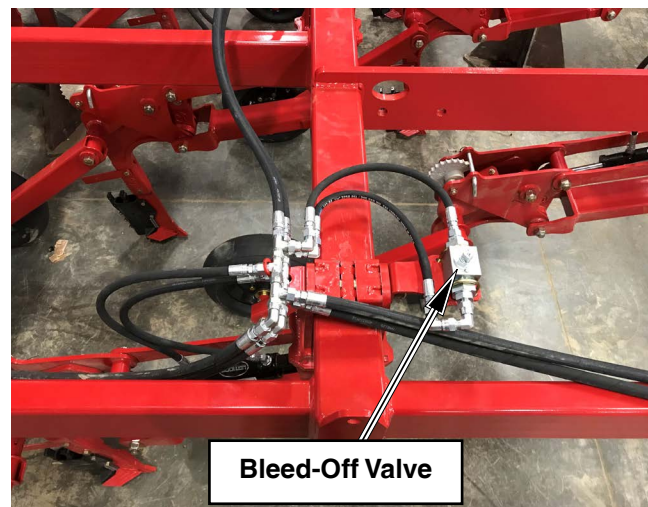

Opener Maintenance - Continued

Hydraulic System Trouble Shooting

If pressure can not be maintained in the hydraulic system, or openers drop rapidly from transport position, a leaky hydraulic cylinder (bypassing oil across the piston seal) may be present. To locate a hydraulic leak in the QUANTUM Air Drill hydraulic system, the following procedure can be used:

1. Remove pressure from the hydraulic system.
2. Check the drill frame and hoses to make sure that the leak is not external (leaking oil out of the circuit).
3. Lift the openers into their raised position.
4. Lock the opener hydraulic ball valve.
5. Watch the openers carefully across the drill and locate the first opener(s) to visibly drop down from the raised position (NOTE: This is the general area of the leaking cylinder, but the first opener to drop is not always the leaking cylinder.).
6. Unlock the "OPENERS" hydraulic ball valve and lift the openers to the raised position and lock the hydraulic remote in the raised position to apply flow to the circuit for about five minutes.
7. Let the hydraulic remote go back to neutral, shut off the tractor, and then go and check the temperature of the opener cylinders by feeling the cylinder barrels. Start at the group of cylinders that were located in step 5) and then work from the outer openers in to center until a "hot" cylinder is located.
8. Under normal conditions the cylinders should remain cool (ambient temperature or slightly above); the opener with a "hot" cylinder barrel has the leaky seal and should be serviced or replaced.

Note: All hydraulic cylinders have a natural leakage rate. The openers on the QUANTUM drill will drop over a long period of time during storage; this is normal. Only check for leaky cylinders if openers drop rapidly from transport in a short period of time.

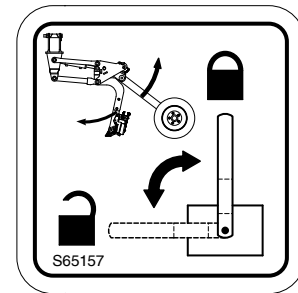

DECAL - S65157

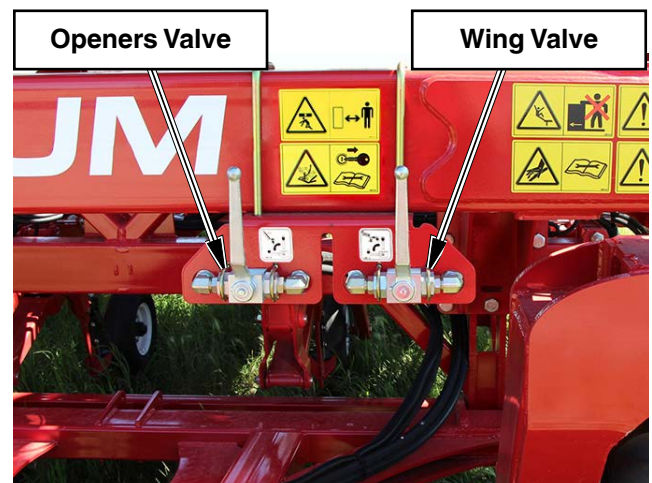

Valves in Locked Position

Maintenance

Hydraulics

Refer to Section 1 regarding hydraulic safety. In addition:

- Inspect hydraulic system for leaks, damaged hoses and loose fittings. **CRITICAL - ACTIVE HYDRAULICS WILL CONTINUE TO LOOSE OIL TO THE ATMOSPHERE/ENVIRONMENT IF A LEAK GOES UNDETECTED - INSPECT REGULARLY.**
- Damaged hoses and hydraulic tubing can only be repaired by replacement. **DO NOT ATTEMPT REPAIRS WITH TAPE OR CEMENTS.** High pressure will burst such repairs and cause system failure and possible injury.
- Always relieve hydraulic pressure from the system before performing maintenance or repairs.
- Leaking cylinders - install a new seal kit.
- Fittings - use liquid Teflon on all NPT hydraulic joints. **Do not use liquid Teflon or Teflon tape on JIC or ORB ends.**
- Hydraulic Hose Connections - when connecting the hoses to the cylinders, tubing, etc. always use one wrench to keep the hose from twisting and another wrench to tighten the union. Excessive twisting will shorten hose life.
- Keep fittings and couplers clean.
- Check the Tractor Manual for proper filter replacement schedule.

Refer to the Trouble Shooting Section.



Contact your nearest Dealer for genuine repair parts. Dealers carry ample stocks and are backed by the manufacture and regional associations.

Caution

Dirt in the hydraulic system could damage O-rings, causing leakage, pressure loss and total system failure.

Note: Extreme care must be taken to maintain a clean hydraulic system. Use only new hydraulic fluid when filling reservoir.

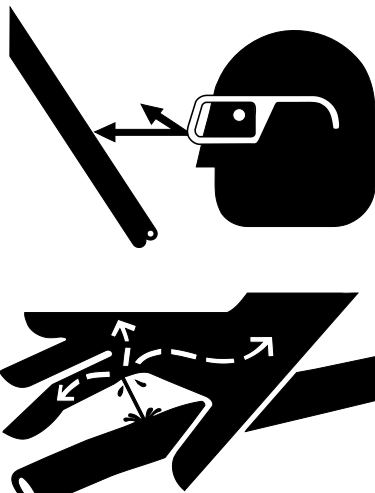

Warning

HIGH-PRESSURE FLUID HAZARD

To prevent serious injury or death:

- Relieve pressure on hydraulic system before servicing or disconnecting hoses.
- Wear proper hand and eye protection when searching for leaks. Use wood or cardboard instead of hands.
- Keep all components in good repair.

Wheel Bearings

Implement Hub

- Position implement in field position.
- Shut tractor off, remove key, and engage park brake.
- Block wheel on tractor.
- Raise the implement wheel enough to clear the surface.
- Securely block implement frame.
- Remove wheel from hub.
- Remove the dust cap, cotter pin, and the slotted nut and washer.
- Be careful when pulling the hub off as not to drop the outer bearing.
- Clean spindle and bearing components with solvent.
- Inspect for wear on bearings, spindle and cups, replace parts as required.
- Do not reuse old seals. Use only new seals when assembling.
- Pack inner hub with bearing grease.
- Be sure bearing and cup are dry and clean.
- Work grease into the bearing rollers, until each part of the bearing is completely full of grease.
- Install inner bearing and cup first, then press new seals in place.
- Place hub on spindle.
- Install outer bearing, washer and slotted nut.
- Tighten nut while turning the wheel until a slight drag is felt.
- Back nut off one slot and install a cotter pin. Bend cotter pin up around nut.
- Pack grease inside the dust cap and tap into position.

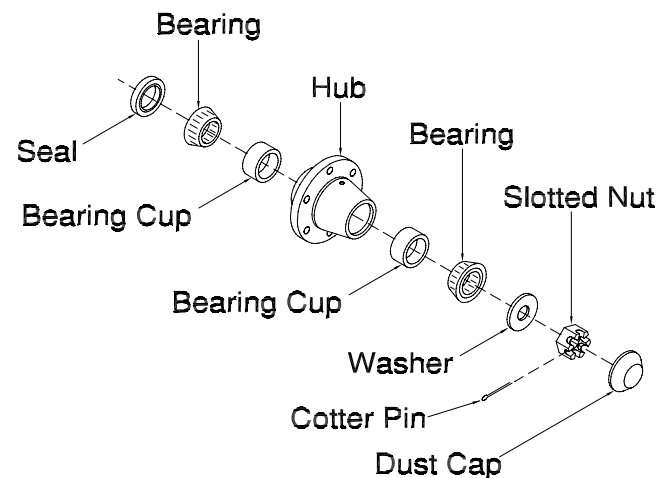

Important

Check wheel bearings for play every
5,000 acres (2,000 hectares)
or yearly, which ever occurs first.
Tighten as required.

Maintenance

Wheel Bearings - Continued

Opener Hub

- Position implement in field position.
- **Relieve all pressure** from the opener circuit using the tractor remote.
- Shut tractor engine off and remove key. Engage park brake before proceeding.
- Place “Openers” ball valve into locked position to prevent accidental oil flow to openers.
- Follow procedure for hub removal and bearing replacement outlined under “Implement Hub”.

Important
Check wheel bearings for play every
5,000 acres (2,000 hectares)
or yearly, which ever occurs first.
Tighten as required.

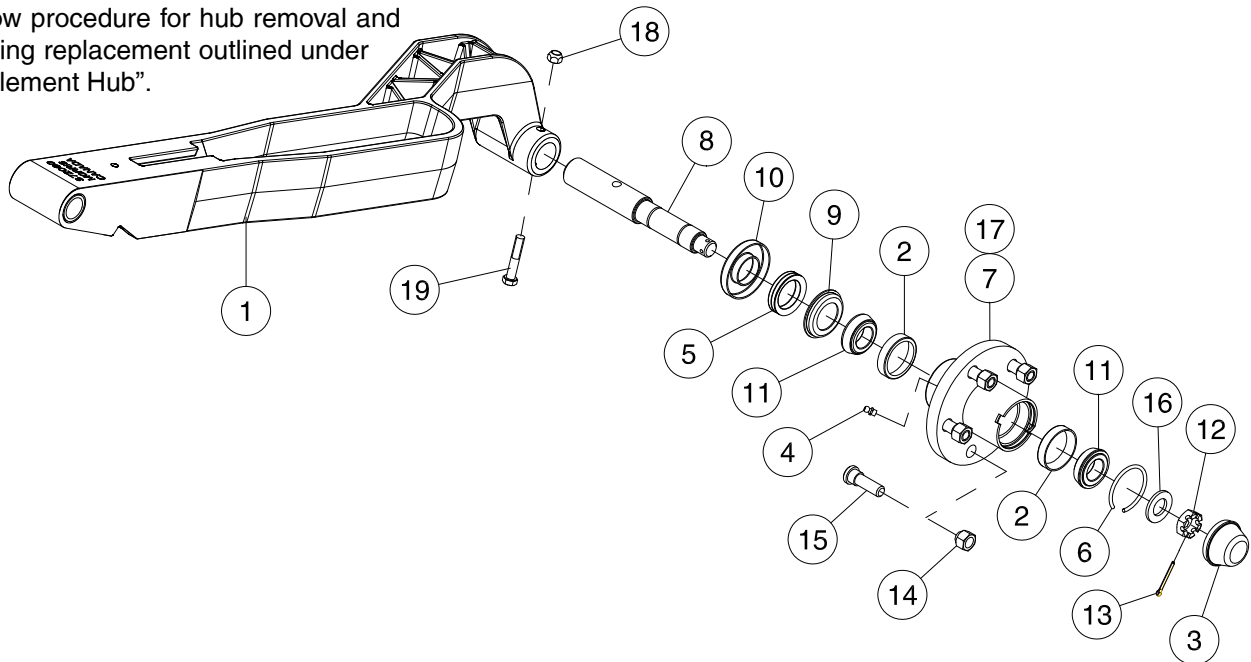

Item	Part No.	Description	Qty
1	S72060	Packer Arm - Right - Shown	1
	S72065	Packer Arm - Left	1
2	N14009	Bearing Cup	2
3	N14011	Dust Cap	1
4	S-752	Grease Zerk - 1/4	1
5	S48842	V-Seal - 1 1/4 Shaft	1
6	S48843	Dust Cap Retaining Wire	1
7	S48844	Hub Casting - 1000 Lb - 5 Bolt	1
8	S48846	Spindle - 1-1/4 Dia	1
9	S48847	Seal Counterface	1
10	S48848	Seal Retainer	1
11	W-4187	Bearing Cone	2
12	S48849	Slotted Jam Nut - 3/4	1
13	W-529	Cotter Pin - 1/8 x 1 Lg	1
14	S50246	Tapered Wheel Nut - 1/2	5
15	S50247	Press-In Wheel Stud - 1/2	5
16	W-476	Washer - 3/4	1
17	S48850	Packer Hub Assembly (Includes Items# 2, 3, 4, 5, 6, 7, 8, 9, 10, 11, 12, 13, 14, 15 & 16) .	1
18	M-3388	Lock Nut - 3/8 Unitorque	1
19	W-480	Hex Bolt - 3/8 x 2 1/2 Lg	1

Wheel Bearings - Continued

Pack Control Hub

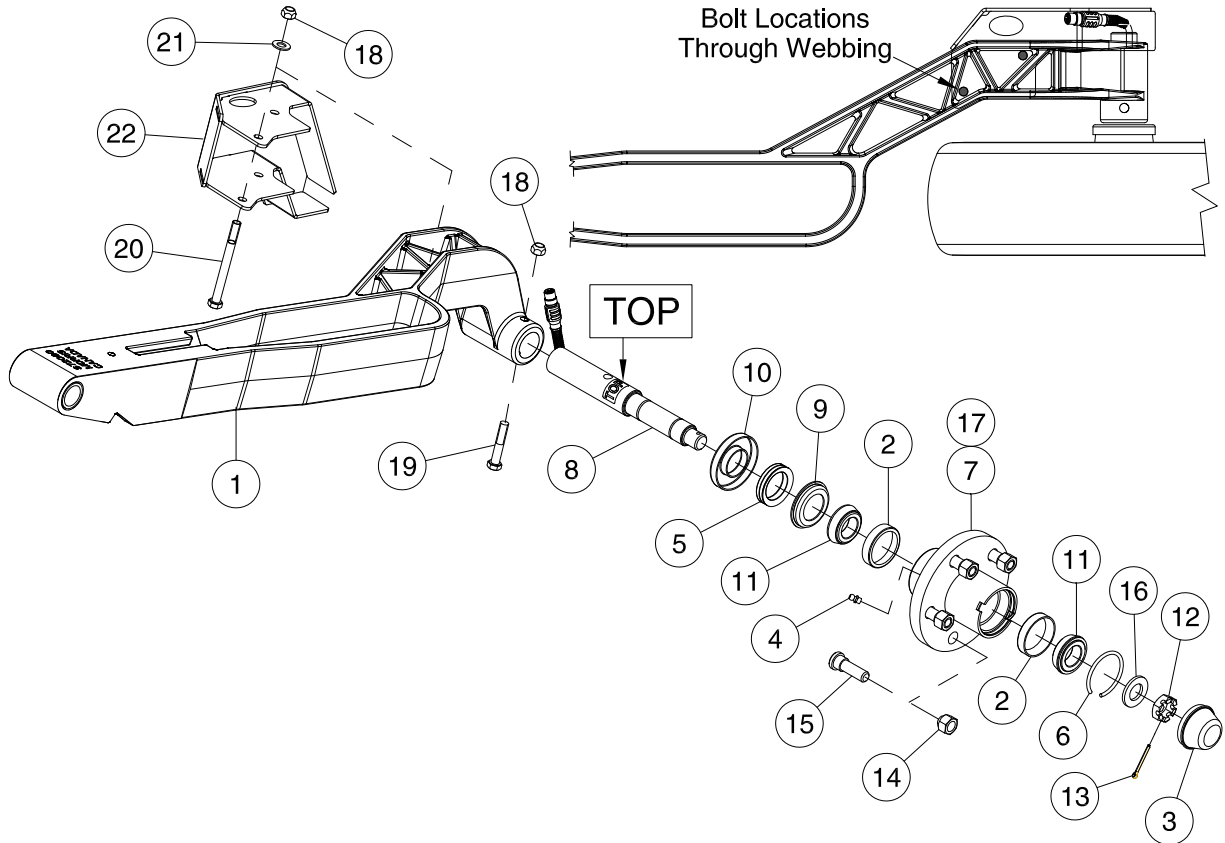

Item	Part No.	Description	Qty
1	S72060	Packer Arm - Right	1
	S72292	Pack Force Spindle and Guard Kit. (Includes ALL Items below)	
2	N14009	Bearing Cup	2
3	N14011	Dust Cap	1
4	S-752	Grease Zerk - 1/4	1
5	S48842	V-Seal - 1 1/4 Shaft	1
6	S48843	Dust Cap Retaining Wire	1
7	S48844	Hub Casting - 1000 Lb - 5 Bolt	1
8	S72200	Spindle - 1-1/4 Dia - Digi-Star	1
9	S48847	Seal Counterface	1
10	S48848	Seal Retainer	1
11	W-4187	Bearing Cone	2
12	S48849	Slotted Jam Nut - 3/4	1
13	W-529	Cotter Pin - 1/8 x 1 Lg	1
14	S50246	Tapered Wheel Nut - 1/2	5
15	S50247	Press-In Wheel Stud - 1/2	5
16	W-476	Washer - 3/4	1
17	S72190	Packer Hub Assembly (Includes Items# 2, 3, 4, 5, 6, 7, 8, 9, 10, 11, 12, 13, 14, 15 & 16)	1
18	M-3388	Lock Nut - 3/8 Unitorque	5
19	W-480	Hex Bolt - 3/8 x 2 1/2 Lg	1
20	C-1550	Hex Bolt - 3/8 x 4 Lg	2
21	D-5489	Washer - 13/32 ID x 13/16 OD x 16 GA	2
22	S72094	Guard -Pack Control - Cast Arm - Right	1

Maintenance

Packer Wheel Assemblies

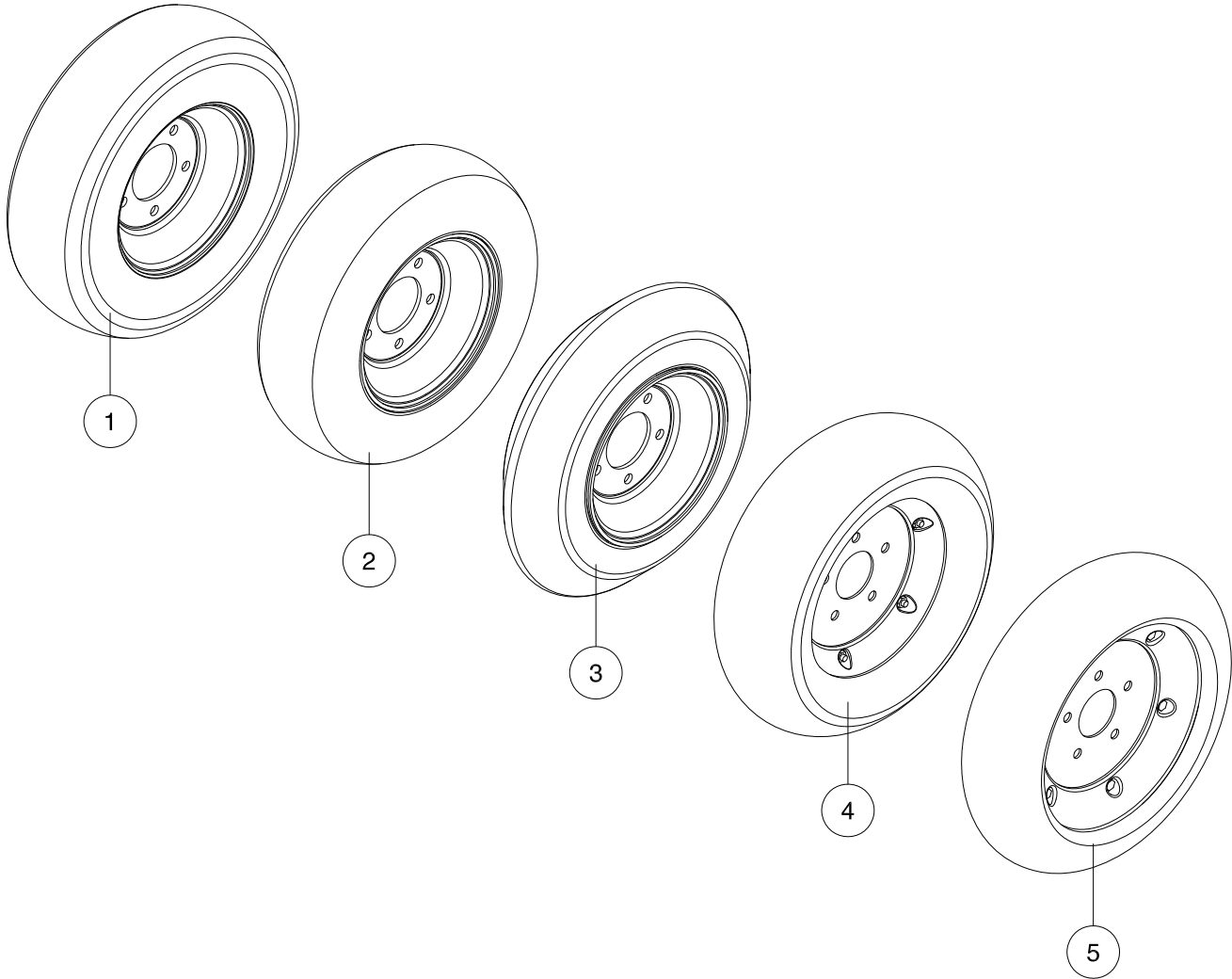

Item	Part No.	Description	Qty
1	S44300	Semi Pneumatic Tire - 480 x 8	1
2	S44900	Semi Pneumatic Tire - 550 x 8	1
3	S47093	"V" Crown Packer Tire - 400 x 8.....	1
	S73310	"V" Crown Packer Tire - 4.50 x 8.....	1
4	S64195	5.5" Otico Tire	1
5	S72075	4.5" AIC Tire	1
	S73086	4.5" HD Tire	1

Section 7: Storage

Section Contents

Preparing for Storage.....	7-2
Wing Lift Cylinder Shaft Protection	7-3
Removing From Storage	7-3

Storage

Preparing for Storage

- To insure longer life and satisfactory operation, store the implement in a shed.
- If building storage is impossible, store away from areas of main activity on firm, dry ground.
- Clean machine thoroughly.
- Inspect all parts for wear or damage.
- Avoid delays - if parts are required, order at the end of the season.
- Lubricate grease fittings. (Refer to Maintenance Section).
- Tighten all bolts to proper specifications (Refer to Maintenance Section).
- For a safer storage, lower the implement into field position and release the hydraulic pressure.
- If implement must be stored in a raised position, ensure that wings are properly secured with lock pins.
- Level implement using hitch jack and block up.
- Relieve pressure from hydraulic system.
- Cover tires with canvas to protect them from the elements when stored outside.
- Coat exposed wing lift cylinder shafts (**Refer to Wing Lift Cylinder Shaft Protection**).
- Paint any surfaces that have become worn.



Warning

Do not allow children to play on or around the machine.

MORRIS PAINT	
Part Number	Description
S73107	Red Powder Touch Up Spray Can
N31087	White MORRIS Spray Can

Wing Lift Cylinder Shaft Protection

The steps summarized below should be followed when protecting chrome plated shafting on equipment:

- Position the equipment as it will be stored, and identify all the exposed portions of the chrome plated shafts.
- Clean dirt and dust from the exposed portions of the shafting using a dry cloth or a cloth which has been dampened with an appropriate solvent.
- Prepare a mixture of 60% oil-based rust inhibitor and 40% Kerosene. Apply a thin coating of this mixture to the exposed surfaces of the chrome plated shafting. No. 1 fuel oil may be substituted for Kerosene. A cloth dipped in the mixture can be used to apply the coating.
- Inspect the shaft surfaces after six months and apply additional corrosion preventative mixture.
- If the equipment is to be moved and then stored again for an extended period of time, the steps above should be repeated for all shafts that were stroked during the move.
- **Before retracting the cylinders the protective coating should be removed**, to prevent fine sand and dirt that has accumulated in the coating, from damaging the shaft seal. **Under no circumstances should sandpaper or other abrasive be used to clean the surfaces.** Plastic or copper wool in combination with an appropriate solvent will remove most of the dirt.



Caution

Dirt in the hydraulic system could damage O-rings, causing leakage, pressure loss and total system failure.

Removing From Storage

- Review Operator's Manual.
- Check tire pressure (Refer to Tire Pressure List)
- Clean machine thoroughly. Remove coating from exposed cylinder shafts (**Refer to Wing Lift Cylinder Shaft Protection**).
- Lubricate grease fittings. (Refer to Lubricating Section).
- Tighten all bolts to proper specifications (Refer to Bolt Torque Chart).

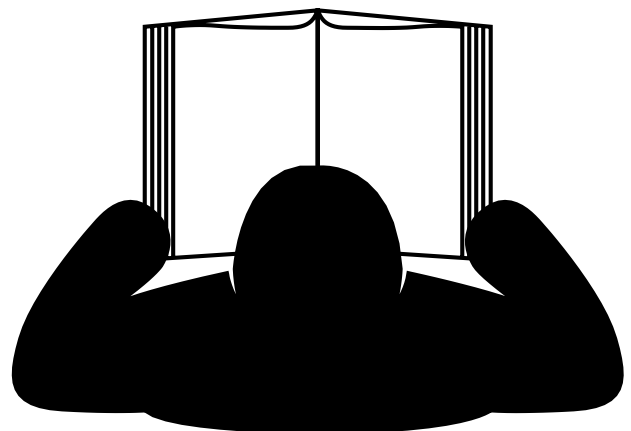

Storage

Notes

Section 8: Troubleshooting

Section Contents

Machine not operating straight.	8-2
Lack of penetration.	8-2
Openers wearing unevenly	8-2
Wing lifting too slowly.	8-2
Wings not lowering.	8-2
One wing will lift, other will not.	8-2
Oil accumulation.	8-2
Openers drop quickly after transport lock valve is closed.	8-2
Openers won't lift or lower.	8-3
Openers won't lift.	8-3
Opener pressure won't change.	8-3
Openers can not be fully pressurized.	8-3
Openers not fully lifting to transport position.	8-4
Excessive seed depth and soil throw.	8-4
Shanks hang back and trip out during normal operation.	8-4
Seed rows covered in loose soil after seeding.	8-4
Packer wheels bounce and chatter excessively in field.	8-4

Troubleshooting

Problem	Cause	Correction
Machine not operating straight.	Uneven opener depth.	Refer to Operation Section on depth adjustment. Check tire pressure.
Lack of penetration.	Openers worn.	Replacement necessary.
	System pressure too low.	Refer to Operation Section on setting maximum system pressure.
Openers wearing unevenly	Tire tracks. Front row always wears more than the others.	Replace worn openers.
Wing lifting too slowly.	Tractor hydraulic pressure.	Repair pump. Pressure relief valve needs resetting.
	Hydraulic breakaways.	Foreign material or sticking. Check compatibility.
	Hose restriction.	Cylinder linkage binding.
Wings not lowering.	Transport valve in locked position.	Place opener valve into unlocked position.
One wing will lift, other will not.	Assembly.	Hoses reversed at cylinder.
	Restriction in line.	Clean.
	Internal cylinder leak.	Repair cylinder.
Oil accumulation.	Damaged seal.	Replace seals.
	Loose fittings.	Tighten hose and pipe connections.
	Scored cylinder shaft will damage shaft seal.	Replace.
	Normal.	Slight seepage from seal is normal.
Openers drop quickly after transport lock valve is closed.	Hydraulic line, fitting or cylinder leak.	Locate leaking line, fitting or cylinder and repair or replace.

Troubleshooting

Problem	Cause	Correction
Openers won't lift or lower.	Openers valve in locked position.	Place openers valve in unlocked position.
	Hydraulic line, fitting or cylinder leak.	Locate leaking line, fitting or cylinder and repair or replace.
	Low oil level.	Fill tractor reservoir.
	Hydraulics clogged.	Replace filter.
	Pivot bolts too tight.	Refer to Maintenance Section on Opener Body Assembly for adjusting procedure.
Openers won't lift.	Tractor Hydraulics not working.	Engage Tractor Hydraulics.
	"S1" Solenoid not actuating.	Check for power and control connections on controller harnessing. Check wire connections to "S1" solenoid. Check wire connections throughout harness, ECU, monitor. Possible failed "S1" solenoid Possible display malfunction
Opener pressure won't change.	Tractor Hydraulics not working.	Engage Tractor Hydraulics.
	"S2" Solenoid not actuating.	Check wire connections to "S2" solenoid. Check wire connections throughout harness, ECU, monitor. Possible failed "S2" solenoid Possible display malfunction
Openers can not be fully pressurized.	Hydraulic line, fitting or cylinder leak.	Locate leaking line, fitting or cylinder and repair or replace .
	"S2" Solenoid not actuating.	Check wire connections to "S2" solenoid. Check wire connections throughout harness, ECU, monitor. Possible failed "S2" solenoid Possible display malfunction

Troubleshooting

Problem	Cause	Correction
Openers not fully lifting to transport position.	Air in hydraulic lines.	Bleed hydraulic system.
	Parallel link pivot bolts too tight.	Loosen pivot bolts in small increments until all openers will drop quickly from raised position under their own weight (put tractor remote in float to allow openers to drop).
Excessive seed depth and soil throw.	Soft field conditions.	Reduce pressure and seed depth settings.
	Ground speed too fast.	Reduce speed and re-check depth.
	Hydraulic pressure too high.	Reduce pressure and re-check depth.
Shanks hang back and trip out during normal operation.	System pressure too low for seed depth and soil conditions.	Adjust reducing valve to higher pressure until shanks no longer hang back.
	Air in hydraulic lines.	Bleed hydraulic system.
Seed rows covered in loose soil after seeding.	Ground speed too fast.	Reduce speed and check field finish.
	Back of drill frame is lifting.	Add factory weight kit to rear depth beams.
Packer wheels bounce and chatter excessively in field.	Packing pressure too low.	Adjust reducing valve to higher pressure until packer arms have desired pressure.
	Depth setting too deep.	Reduce opener seeding depth.



www.morrisequipment.ca

1891 Albert Street North,
Regina, Saskatchewan
S4R 8R7 Canada
Phone: 306-933-8585
Fax: 306-933-8626

It is the policy of Morris Equipment Ltd. to improve its products whenever it is possible to do so. Morris Equipment reserves the right to make changes or add improvements at any time without incurring any obligation to make such changes on machines sold previously.